

HARTZELL PROPELLER INC.
One Propeller Place
Piqua, Ohio 45356-2634 U.S.A.
Telephone: 937.778.4200
Fax: 937.778.4391

HARTZELL

MANUAL REVISION TRANSMITTAL
Manual 169 (61-00-69)
Propeller Owner's Manual and Logbook

REVISION 3 dated May 2014

Attached is a copy of Revision 3 to Hartzell Manual 169.

Page Control Chart for Revision 3:

Remove

Page No.

COVER/INSIDE COVER

REVISIONS HIGHLIGHTS

pages 5 thru 8

LIST OF EFFECTIVE PAGES

pages 17 thru 20

TABLE OF CONTENTS

pages 21 thru 32

INTRODUCTION

pages 1-1 thru 1-14

INSTALLATION AND REMOVAL

pages 3-1 thru 3-126

TESTING AND
TROUBLESHOOTING

pages 4-1 thru 4-16

INSPECTION AND CHECK

pages 5-3 thru 5-16

pages 5-19 thru 5-24

Insert

Page No.

COVER/INSIDE COVER

REVISIONS HIGHLIGHTS

pages 5 thru 8

LIST OF EFFECTIVE PAGES

pages 17 and 18

TABLE OF CONTENTS

pages 19 thru 30

INTRODUCTION

pages 1-1 thru 1-16

INSTALLATION AND REMOVAL

pages 3-1 thru 3-132

TESTING AND
TROUBLESHOOTING

pages 4-1 thru 4-16

INSPECTION AND CHECK

pages 5-3 thru 5-16

pages 5-19 thru 5-24

continued on next page

Page Control Chart for Revision 3 (continued):

Remove
Page No.

Insert
Page No.

MAINTENANCE PRACTICES
pages 6-1 and 6-32

MAINTENANCE PRACTICES
pages 6-1 and 6-28

NOTE 1: When the manual revision has been inserted in the manual, record the information required on the Record of Revisions page in this manual.

NOTE 2: Pages distributed in this revision may include pages from previous revisions if they are on the opposite side of revised pages. This is done as a convenience to those users who wish to print a two-sided copy of the new revision.

Manual No. 169

61-00-69

Revision 3

May 2014

Propeller Owner's Manual and Logbook

Steel Hub Reciprocating Propellers with Aluminum Blades

Two Blade	Three Blade
(B)HC-92()F-1()	HC-93Z20-1()
HC-92()K-1()	HC-93ZF-2()
(B)HC-92()F-2()	HC-93Z20-2()
HC-92()K-2()	HC-93Z30-2()
(B)HC-92()F-3()	
HC-92WF-5A	
HC-92()F-8()	
HC-92()K-8()	

Hartzell Propeller Inc.

One Propeller Place

Piqua, OH 45356-2634 U.S.A.

Ph: 937-778-4200 (Hartzell Propeller Inc)

Ph: 937-778-4379 (Product Support)

937-778-4391 (Product Support Fax)

© 2000, 2005, 2009, 2014 - Hartzell Propeller Inc. - All rights reserved

REVISION 3 HIGHLIGHTS

- COVER
 - Revised to match this manual revision
- REVISION HIGHLIGHTS
 - Revised to match this manual revision
- LIST OF EFFECTIVE PAGES
 - Revised to match this manual revision
- TABLE OF CONTENTS
 - Revised to match this manual revision
- INTRODUCTION
 - Added a statement that the manual is accepted by the FAA.
 - Changed "Hartzell" to "Hartzell Propeller Inc."
 - Added the section "Inspection, Repair, and Overhaul"
 - Added the section "Safe Handling of Paints and Chemicals"
 - Added the section "Propeller Critical Parts"
 - Revised the section "Reference Publications"
 - Revised the section "Definitions"
 - Revised the section "Abbreviations"
 - Other minor formatting changes
- INSTALLATION AND REMOVAL
 - Changed "Hartzell" to "Hartzell Propeller Inc."
 - Added option for safety cable for mounting hardware
 - Revised Table 3-1, O-ring and Propeller Mounting Hardware Identification
 - Revised the section "Pre-Installations"
 - Added Cautions about "Propeller Critical Parts"
 - Added Warnings about "Adhesives and solvents"
 - Revised the torque value for the governor mounting nuts
 - Revised the installation of the felt seal instruction in section "Installing the 20 Spline HC-93Z20-1() Propeller Models" and section "Installing the 20 Spline HC-93Z20-2() Propeller Models"
 - Other minor formatting changes

REVISION 3 HIGHLIGHTS

TESTING AND TROUBLESHOOTING

- Added Cautions about "Propeller Critical Parts"
- Added wording for "a certified propeller repair station with the appropriate rating"
- Other minor formatting changes

INSPECTION AND CHECK

- Added Cautions about "Propeller Critical Parts"
- Revised the section "Pre-Flight Checks"
- Added wording for "a certified propeller repair station with the appropriate rating"
- Other minor formatting changes

MAINTENANCE PRACTICES

- Added Cautions about "Propeller Critical Parts"
- Changed "Hartzell" to "Hartzell Propeller Inc."
- Revised the section "Blade Repairs"
- Added Warning about "Blade Repairs"
- Revised Caution about shotpeened blades
- Added wording for "a certified propeller repair station with the appropriate rating"
- Revised the section "Painting After Repair"
- Other minor formatting changes

REVISION HIGHLIGHTS1. Introduction

A. General

This is a list of current revisions that have been issued against this manual. Please compare it to the RECORD OF REVISIONS page to ensure that all revisions have been added to the manual.

B. Components

- (1) Revision No. indicates the revisions incorporated in this manual.
- (2) Issue Date is the date of the revision.
- (3) Comments indicates the level of the revision.
 - (a) New Issue is a new manual distribution. The manual is distributed in its entirety. All the page revision dates are the same and no change bars are used.
 - (b) Reissue is a revision to an existing manual that includes major content and/or major format changes. The manual is distributed in its entirety. All the page revision dates are the same and no change bars are used.
 - (c) Major Revision is a revision to an existing manual that includes major content or minor content changes over a large portion of the manual. The manual is distributed in its entirety. All the page revision dates are the same, but change bars are used to indicate the changes incorporated in the latest revision of the manual.
 - (d) Minor Revision is a revision to an existing manual that includes minor content changes to the manual. Only the revised pages of the manual are distributed. Each page retains the date and the change bars associated with the last revision to that page.

<u>Revision No.</u>	<u>Issue Date</u>	<u>Comments</u>
Original	July/00	New Issue
Revision 1	Aug/05	Minor Revision
Revision 2	May/09	Minor Revision
Revision 3	May/14	Minor Revision

LIST OF EFFECTIVE PAGES

Chapter	Page	Revision	Date
Cover	Cover/Back Cover	Rev. 3	May/14
Message	1 thru 4	Original	July/00
Revision Highlights	5 thru 8	Rev. 3	May/14
Record of Revisions	9 and 10	Original	July/00
Record of Temporary Revisions	11 and 12	Original	July/00
Service Documents List	13 and 14	Rev. 1	Aug/05
Airworthiness Limitations	15 and 16	Rev. 2	May/09
List of Effective Pages	17 and 18	Rev. 3	May/14
Table of Contents	19 thru 30	Rev. 3	May/14
Introduction	1-1 thru 1-16	Rev. 3	May/14
Description and Operation	2-1 thru 2-6	Original	July/00
Description and Operation	2-7	Rev. 1	Aug/05
Description and Operation	2-8 thru 2-10	Original	July/00
Description and Operation	2-11	Rev. 1	Aug/05
Description and Operation	2-12 thru 2-15	Original	July/00
Description and Operation	2-16 thru 2-19	Rev. 1	Aug/05
Description and Operation	2-20	Original	July/00
Description and Operation	2-21	Rev. 1	Aug/05
Description and Operation	2-22 thru 2-25	Original	July/00
Description and Operation	2-26 thru 2-30	Rev. 1	Aug/05
Description and Operation	2-31 and 2-32	Original	July/00
Description and Operation	2-33	Rev. 1	Aug/05
Description and Operation	2-34 thru 2-40	Original	July/00
Installation and Removal	3-1 thru 3-132	Rev. 3	May/14
Testing and Troubleshooting	4-1 thru 4-16	Rev. 3	May/14
Inspection and Check	5-1 thru 5-2	Rev. 2	May/09

LIST OF EFFECTIVE PAGES

Chapter	Page	Revision	Date
Inspection and Check	5-3 thru 5-8	Rev. 3	May/14
Inspection and Check	5-9	Rev. 2	May/09
Inspection and Check	5-10 thru 5-13	Rev. 3	May/14
Inspection and Check	5-14	Rev. 2	May/09
Inspection and Check	5-15 and 5-16	Rev. 3	May/14
Inspection and Check	5-17 and 5-18	Rev. 2	May/09
Inspection and Check	5-19 thru 5-21	Rev. 3	May/14
Inspection and Check	5-22 and 5-23	Rev. 2	May/09
Inspection and Check	5-24	Rev. 3	May/14
Maintenance Practices	6-1 and 6-28	Rev. 3	May/14
Anti-ice and De-ice Systems	7-1 and 7-2	Rev. 2	May/09
Anti-ice and De-ice Systems	7-3 and 7-4	Rev. 1	Aug/05
Anti-ice and De-ice Systems	7-5 thru 7-8	Rev. 2	May/09
Records	8-1 thru 8-4	Original	July/00

TABLE OF CONTENTS

Page

REVISION HIGHLIGHTS	5
RECORD OF REVISIONS	9
RECORD OF TEMPORARY REVISIONS	11
SERVICE DOCUMENTS LIST	13
AIRWORTHINESS LIMITATIONS	15
LIST OF EFFECTIVE PAGES	17
TABLE OF CONTENTS.....	19
INTRODUCTION	1-1
1. Purpose	1-3
2. Airworthiness Limits.....	1-3
3. Airframe or Engine Modifications.....	1-3
4. Restrictions and Placards.....	1-4
5. General.....	1-4
A. Personnel Requirements	1-4
B. Maintenance Practices.....	1-5
C. Continued Airworthiness	1-7
D. Propeller Critical Parts	1-7
6. Reference Publications.....	1-8
7. Definitions.....	1-9
8. Abbreviations.....	1-13
9. Hartzell Product Support	1-14
10. Warranty Service	1-14
11. Hartzell Recommended Facilities	1-15
DESCRIPTION AND OPERATION.....	2-1
1. Description of Propeller and Systems	2-3
A. Constant Speed, Non-counterweighted, Non-Feathering Propellers.....	2-7
B. Constant Speed, Counterweighted, Non-feathering Propellers.....	2-11

TABLE OF CONTENTS

Page

C. Constant Speed, Feathering Propellers.....	2-17
D. Constant Speed, Feathering and Reversing Propellers (External Beta System).....	2-21
E. Constant Speed, Feathering and Reversing Propellers...	2-27
2. Model Designation.....	2-32
A. Steel Hub Propeller Model Identification.....	2-32
B. Aluminum Blade Model Identification.....	2-33
3. Governors.....	2-35
A. Theory of Operation.....	2-35
B. Governor Types.....	2-38
C. Identification of Hartzell Governors.....	2-38
4. Propeller Anti-Ice and De-Ice Systems.....	2-39
A. Propeller Anti-Ice System.....	2-39
B. Propeller De-Ice System.....	2-40

INSTALLATION AND REMOVAL 3-1

1. Tools, Consumables, and Expendables.....	3-5
A. Tooling.....	3-5
B. Consumables.....	3-5
C. Expendables.....	3-5
2. O-ring and Propeller Mounting Hardware Identification.....	3-6
3. Pre-Installation.....	3-10
A. Inspection of Shipping Package.....	3-10
B. Uncrating.....	3-10
C. Inspection after Shipment.....	3-10
D. Reassembly of a Propeller Disassembled for Shipment..	3-10
4. Propeller Assembly Installation.....	3-11
A. Precautions.....	3-11
B. O-ring and Propeller Mounting Hardware Identification ...	3-12
C. Installing the F Flange Propeller Models BHC-92()F-1D1.....	3-14

<u>TABLE OF CONTENTS</u>		<u>Page</u>
D. Installing the F Flange Propeller Models HC-92()F-8()		3-22
E. Installing the K Flange Propeller Models HC-92()K-1D, and HC-92()K-8()		3-28
F. Installing the F Flange Propeller Models HC-92ZF-2() and HC-93ZF-2()		3-34
G. Installing the K Flange Propeller Models HC-92()K-2()		3-40
H. Installing the F Flange Propeller Models (B)HC-92()F-3		3-45
I. Installing the F Flange Propeller Models BHC-92(W,Z)F-3(L)G		3-57
J. Installing the F Flange Propeller Model HC-92WF-5A		3-65
K. Installing the 20 Spline HC-93Z20-1() Propeller Models		3-74
L. Installing the 20 Spline HC-93Z20-2() and the 30 Spline HC-93Z30-2() Propeller Models		3-81
5. Post-Installation Checks		3-96
6. Propeller Assembly Removal.....		3-97
A. Removing the F Flange Propeller Models BHC-92()F-1D1		3-97
B. Removing the F Flange Propeller Models HC-92()F-8()		3-99
C. Removing the K Flange Propeller Models HC-92()K-1D, and HC-92()K-8()		3-102
D. Removing the F Flange Propeller Models HC-92ZF-2() and HC-93ZF-2()		3-105
E. Removing the K Flange Propeller Models HC-92()K-2()		3-108
F. Removing the F Flange Propeller Models (B)HC-92()F-3		3-112
G. Removing the F Flange Propeller Models BHC-92(W,Z)F-3(L)G		3-115
H. Removing the F Flange Propeller Model HC-92WF-5A.....		3-120

TABLE OF CONTENTS

Page

- I. Removing the 20 Spline Propeller Models
HC-93Z20-1() 3-125
- J. Removing the 20 Spline HC-93Z20-2() and the
30 Spline HC-93Z30-2() Propeller Models 3-128

TESTING AND TROUBLESHOOTING 4-1

- 1. Operational Tests..... 4-3
 - A. Initial Run-Up 4-3
 - B. Static RPM Check..... 4-4
 - C. Post-Run Check..... 4-4
- 2. Propeller Ice Protection Systems 4-4
 - A. Electric De-ice System..... 4-4
 - B. Anti-ice System 4-5
- 3. Troubleshooting 4-5
 - A. Incorrect Maximum RPM (on Ground)..... 4-5
 - B. Hunting and Surging 4-6
 - C. Engine Speed Varies with Airspeed 4-7
 - D. Loss of Propeller Control -
HC-92()()-8() Propeller Models: 4-9
 - E. Loss of Propeller Control - (B)HC-92()F-1(),
HC-92()K-1(), HC-93Z20-1(), HC-92()()-2(),
HC-93()()-2(), (B)HC-92()F-3(), and
HC-92WF-5A Propeller Models:..... 4-9
 - F. Failure to Feather or Feathers Slowly - HC-92()()-2(),
HC-93()()-2(), and HC-92WF-5A Propeller Models:..... 4-10
 - G. Failure to Unfeather - HC-92()()-2(),
HC-93()()-2(), and HC-92WF-5A Propeller Models..... 4-10
 - H. Start Locks (Anti-Feather Latches) Fail to Engage on
Shutdown - HC-9()()-2()() and
HC-92WF-5A Propellers: 4-11
 - I. Vibration 4-12
 - J. Propeller Overspeed 4-13

TABLE OF CONTENTSPage

K. Propeller Underspeed	4-13
L. Oil or Grease Leakage	4-14
INSPECTION AND CHECK.....	5-1
1. Pre-Flight Checks	5-3
2. Operational Checks	5-5
3. Required Periodic Inspections and Maintenance	5-6
A. Periodic Inspection.....	5-6
B. Periodic Maintenance	5-7
C. Airworthiness Limitations	5-7
D. Overhaul Periods	5-8
4. Inspection Procedures.....	5-10
A. Blade Damage	5-10
B. Grease or Oil Leakage.....	5-10
C. Vibration	5-12
D. Tachometer Inspection.....	5-13
E. Blade Track	5-15
F. Loose Blades	5-15
G. Corrosion	5-16
H. Spinner Damage	5-16
I. Electric De-ice System.....	5-16
J. Anti-ice System	5-16
5. Special Inspections.....	5-19
A. Overspeed	5-19
B. Lightning Strike	5-20
C. Foreign Object Strike/Ground Strike	5-22
D. Fire Damage or Heat Damage.....	5-24
6. Long Term Storage	5-24

TABLE OF CONTENTS

Page

MAINTENANCE PRACTICES	6-1
1. Cleaning	6-3
A. General Cleaning	6-3
B. Spinner Cleaning and Polishing.....	6-3
2. Lubrication	6-5
A. Lubrication Intervals.....	6-5
B. Lubrication Procedure.....	6-6
C. Approved Lubricants.....	6-9
3. Carbon Block Assemblies	6-10
A. Inspection.....	6-10
B. Replacement of A-3026 Carbon Block Unit in the A-3044 Carbon Block Assembly	6-10
C. Installation of the A-3044 Carbon Block Assembly	6-11
4. Blade Repairs	6-13
A. Repair of Nicks or Gouges.....	6-13
B. Repair of Bent Blades	6-15
5. Painting After Repair.....	6-16
A. General	6-16
B. Painting of Aluminum Blades	6-17
6. Dynamic Balance.....	6-19
A. Overview	6-19
B. Inspection Procedures Before Balancing.....	6-20
C. Placement of Balance Weights for Dynamic Balance.....	6-21
7. Propeller Low Pitch Setting	6-23
A. Low Pitch Stop - All Propeller Models	6-23
B. Low pitch measurement on propeller models HC-9() () -2() () :	6-24
C. Low pitch measurement on propeller models (B)HC-9() () -1() () and HC-92() () -8() :	6-24
D. Low pitch measurement on propeller models HC-92() () -3() and HC-92WF-5A.	6-25

TABLE OF CONTENTS

Page

E. Adjusting Low Pitch Angle - Propeller Models BHC-92()f-3() () and HC-92WF-5A	6-25
8. High Pitch (Minimum RPM) Stop - Propeller models HC-9() ()-1() () , HC-92() ()-3() () , and HC-92() ()-8()	6-28
9. Feathering Pitch Stop Adjustment - Propeller Models HC-9() ()-2() () and HC-92WF-5A	6-28
10. Start Lock Adjustment - Propeller models HC-9() ()-2() () and HC-92WF-5A	6-28
11. Propeller Ice Protection Systems	6-28
ANTI-ICE AND DE-ICE SYSTEMS	7-1
1. Introduction	7-3
A. Propeller De-ice System	7-3
B. Propeller Anti-ice System	7-3
2. System Description	7-4
A. De-ice System	7-4
B. Anti-ice System	7-5
3. De-ice System Functional Tests	7-5
4. Anti-ice System Functional Tests	7-5
5. De-ice and Anti-ice System Inspections	7-6
A. De-ice System Inspections	7-6
B. Anti-ice System Inspections	7-6
6. De-ice and Anti-ice System Troubleshooting	7-6
A. De-ice System Troubleshooting	7-6
B. Anti-ice System Troubleshooting	7-7
RECORDS	8-1
1. Introduction	8-3
2. Record Keeping	8-3
A. Information to be Recorded	8-3

LIST OF FIGURESPage

Steel Hub Unit (For Splined Shaft Mounting)	Figure 2-1	2-3
Spline Shaft Attachment	Figure 2-2	2-4
Flanged Attachment	Figure 2-3	2-5
Constant Speed, Nonfeathering, Non-counterweighted Propeller Assembly	Figure 2-4	2-6
Constant Speed, Nonfeathering, Counterweighted Propeller Assembly	Figure 2-5	2-10
Constant Speed, Feathering Propeller Assembly (Flanged Attachment, Short Piston)	Figure 2-6	2-14
Constant Speed, Feathering Propeller Assembly (Splined Attachment, Short Piston)	Figure 2-7	2-15
Constant Speed, Feathering Propeller Assembly (Splined Attachment, Long Piston)	Figure 2-8	2-16
Constant Speed, Feathering, and Reversing Propeller Assembly	Figure 2-9	2-20
Fundamental Elements of a Reversing System	Figure 2-10	2-22
Constant Speed, Feathering and Reversing Propeller Assembly (External Beta System)	Figure 2-11	2-26
Governor in Onspeed Condition	Figure 2-12	2-34
Governor in Underspeed Condition	Figure 2-13	2-34
Governor in Overspeed Condition	Figure 2-14	2-34
Feathering Governor	Figure 2-15	2-36
Synchronizer/Synchrophaser Governor	Figure 2-16	2-36
BHC-92()F-1D1 Propeller Assembly	Figure 3-1	3-13
Installing F Flange Propeller on the Engine Flange	Figure 3-2	3-15

<u>LIST OF FIGURES</u>		<u>Page</u>
Determining Torque Value When Using Torquing Adapter	Figure 3-3	3-16
HC-92()(-)1D,-8() Propeller Assembly	Figure 3-4	3-21
K Flange Installation on -1 Propeller Models	Figure 3-5	3-25
Installing K Flange Propeller on the Engine Flange	Figure 3-6	3-27
HC-92ZF-2(), HC-92()K-2() Propeller Assembly	Figure 3-7	3-32
HC-93ZF-2() Propeller Assembly	Figure 3-8	3-33
K Flange Installation on -2 Propeller Models	Figure 3-9	3-39
(B)HC-92()F-3 Propeller Assembly	Figure 3-10	3-46
Tool for Decompressing External Beta System	Figure 3-11	3-47
HC-92WF-3 Installation on TSIO-520-C Engine	Figure 3-12	3-47
Installation of Beta Valve, Governor, and Linkage	Figure 3-13	3-49
Carbon Block and Beta Ring Clearance	Figure 3-14	3-50
Carbon Block Assembly	Figure 3-15	3-50
Adjusting Propeller Reverse Control System	Figure 3-16	3-53
BHC-92(W,Z)F-3(L)G Propeller Assembly	Figure 3-17	3-59
BHC-92(W,Z)F-3(L)G Installation	Figure 3-18	3-60
HC- 92WF-5A Propeller Assembly	Figure 3-19	3-66
HC-92WF-5A Installation	Figure 3-20	3-68

LIST OF FIGURES

Page

HC-93Z20-1() Propeller Assembly.....	Figure 3-21	3-76
Installing Piston O-ring and Felt Dust Seal.....	Figure 3-22	3-78
HC-93Z20-2A(1), -2B, -2C, -2D1 Propeller Assembly.....	Figure 3-23	3-83
HC-93Z20-2C1 Propeller Assembly	Figure 3-24	3-84
HC-93Z30-2E Propeller Assembly.....	Figure 3-25	3-85
Piston-to-Link Arm Attachment Details	Figure 3-26	3-87
Spring Assembly-to-Cylinder Attachment Details	Figure 3-27	3-89
Feathering Spring Assembly.....	Figure 3-28	3-90
Rear Hub Mounting Parts on 30-Spline Shaft Propeller.....	Figure 3-29	3-91
Safelying the Shaft Nut on a Splined Shaft Propeller.....	Figure 3-30	3-93
Reversing (Beta) System and Governing Hardware	Figure 3-31	3-117
Disconnecting the Beta Ring	Figure 3-32	3-123
Checking Blade Track.....	Figure 5-1	5-14
Blade Play	Figure 5-2.....	5-14
Reciprocating Engine Overspeed Limits	Figure 5-3.....	5-18
Lubrication Fitting	Figure 6-1	6-4
Lubrication Label	Figure 6-2.....	6-6
Repair Limitations.....	Figure 6-3.....	6-12
Location of Balance Weights	Figure 6-4	6-22
Adjusting Low Pitch Angle	Figure 6-5.....	6-26

	<u>Page</u>
O-ring and Propeller Mounting Hardware Identification	Table 3-1 3-6
 Torque Values Table	Table 3-2 3-17
Approved Paints	Table 6-1 6-19

(This page is intentionally blank.)

INTRODUCTION - CONTENTS

1. Purpose.....	1-3
2. Airworthiness Limits.....	1-3
3. Airframe or Engine Modifications	1-3
4. Restrictions and Placards	1-4
5. General	1-4
A. Personnel Requirements	1-4
B. Maintenance Practices.....	1-5
C. Continued Airworthiness	1-7
D. Propeller Critical Parts	1-7
6. Reference Publications	1-8
7. Definitions	1-9
8. Abbreviations	1-13
9. Hartzell Propeller Inc. Product Support.....	1-14
10. Warranty Service.....	1-14
11. Hartzell Propeller Inc. Recommended Facilities	1-15

(This page is intentionally blank.)

1. Purpose

- A. This manual has been reviewed and accepted by the FAA. Additionally, the Airworthiness Limitations Section of this manual has been approved by the FAA.

CAUTION: KEEP THIS MANUAL WITH THE PROPELLER, OR WITH THE AIRCRAFT ON WHICH IT IS INSTALLED, AT ALL TIMES. THE LOG BOOK RECORD WITHIN THIS MANUAL MUST BE MAINTAINED, RETAINED CONCURRENTLY, AND BECOME A PART OF THE AIRCRAFT AND ENGINE SERVICE RECORDS.

- B. This manual supports the following two and three-bladed, "9" type steel hub reciprocating propellers: constant speed, nonfeathering; constant speed, feathering; and constant speed, feathering, and reversing.
- C. The purpose of this manual is to enable qualified personnel to install, operate, and maintain a Hartzell Propeller Inc. propeller. Separate manuals are available concerning overhaul procedures and specifications for the propeller.
- D. This manual covers different design types. Sample hub and blade model numbers within each design are covered in the Description and Operation chapter of this manual.

NOTE: All propeller models covered by this manual use aluminum propeller blades.

2. Airworthiness Limits

- A. Refer to the Airworthiness Limitations section of this manual for Airworthiness Limits information.

3. Airframe or Engine Modifications

- A. Propellers are approved vibrationally on airframe and engine combinations based on tests or analysis of similar installations. This data has demonstrated that propeller stress levels are affected by airframe configuration, airspeed, weight, power, engine configuration, and flight maneuvers. Aircraft modifications that can effect propeller stress include, but are not limited to: aerodynamic changes ahead of or behind the propeller, realignment of the thrust axis, increasing or decreasing airspeed limits, increasing or decreasing weight limits (less significant on piston engines), and the addition of approved flight maneuvers (utility and aerobatic).

- B. Engine modifications can also affect the propeller. The two primary categories of engine modifications are those that affect structure and those that affect power. An example of a structural engine modification is the alteration of the crankshaft or damper of a piston engine. Any change to the weight, stiffness or tuning of rotating components could result in a potentially dangerous resonant condition that is not detectable by the pilot. Most common engine modifications affect the power during some phase of operation. Some increase the maximum power output, while others improve the power available during hot and high operation (flat rating) or at off-peak conditions. Examples of such engine modifications include, but are not limited to: changes to the compressor, power turbine, or hot section of a turboprop engine; and on piston engines, the addition or alteration of a turbocharger or turbonormalizer, increased compression ratio, increased RPM, altered ignition timing, electronic ignition, full authority digital electronic controls (FADEC), or tuned induction or exhaust.
- C. All such modifications must be reviewed and approved by the propeller manufacturer before obtaining approval on the aircraft.

4. Restrictions and Placards

- A. The propellers covered by this manual may have a restricted operating range that requires a cockpit placard. The restrictions, if present, will vary depending on the propeller, blade, engine, and/or aircraft model. Review the propeller and aircraft type certificate data sheet (TCDS), Pilot Operating Handbook (POH), and any applicable Airworthiness Directives for specific information.

5. General

A. Personnel Requirements

(1) Inspection, Repair, and Overhaul

- (a) Compliance to the applicable regulatory requirements established by the Federal Aviation Administration (FAA) or foreign equivalent is mandatory for anyone performing or accepting responsibility for any inspection and/or repair and/or overhaul of any Hartzell Propeller Inc. product.

- I
 - (b) Personnel performing maintenance on steel hub propellers are expected to have sufficient training and certifications (when required by the applicable Aviation Authority) to accomplish the work required in a safe and airworthy manner.
- B. Maintenance Practices
 - (1) The propeller and its components are highly vulnerable to damage while they are removed from the engine. Properly protect all components until they are reinstalled on the engine.
 - (2) Never attempt to move the aircraft by pulling on the propeller.
 - (3) Avoid the use of blade paddles, if possible. Do not place the blade paddle in the area of the de-ice boot when applying torque to a blade assembly. Place the blade paddle in the thickest area of the blade, just outside of the de-ice boot. Use one blade paddle per blade.
 - (4) Use only the approved consumables, e.g. cleaning agents, lubricants, etc.
 - (5) Safe Handling of Paints and Chemicals
 - (a) Always use caution when handling or being exposed to paints and/or chemicals during propeller overhaul and maintenance procedures.
 - (b) Before using paint or chemicals, always read the manufacturer's label on the container and follow specified instructions and procedures for storage, preparation, mixing, and application.
 - (c) Refer to the product's Material Safety Data Sheet (MSDS) for detailed information about physical properties, health, and physical hazards of any chemical.
 - (6) Observe applicable torque values during maintenance.

- (7) Before installing the propeller on the engine, the propeller must be statically balanced. New propellers are statically balanced at Hartzell Propeller Inc. Overhauled propellers must be statically balanced by a certified propeller repair station with the appropriate rating before return to service.

NOTE: Dynamic balance is recommended, but may be accomplished at the discretion of the operator, unless specifically required by the airframe or engine manufacturer. Dynamic balancing is to be accomplished in accordance with the procedures and limitations in Maintenance Practices chapter of this manual. Additional procedures may be found in the aircraft maintenance manual.

- (8) As necessary, use a soft, non-graphite pencil or crayon to make identifying marks on components.
- (9) As applicable, follow military standard NASM33540 for safety wire, safety cable, and cotter pin general practices. Use 0.032 inch (0.81 mm) diameter stainless steel safety wire, unless otherwise indicated.
- (10) The airframe manufacturer's manuals should be used in addition to the information in this manual due to possible special requirements for specific aircraft applications.
- (11) If the propeller is equipped with an anti-ice system, applicable instructions and technical information can be obtained by contacting Hartzell Propeller Inc. Product Support at (937) 778-4379 (business hours are 8:00 a.m. through 5:00 p.m., United States Eastern Time).
- (12) If the propeller is equipped with an ice protection system that uses components supplied by Hartzell Propeller Inc., applicable instructions and technical information for the components supplied by Hartzell Propeller Inc. can be found in the following publications, available on the Hartzell Propeller Inc. website at www.hartzellprop.com.
 - (a) Hartzell Propeller Inc. Manual 180 (30-61-80)
- Propeller Ice Protection System Manual
 - (b) Hartzell Propeller Inc. Manual 180 (30-61-81)
- Propeller Ice Protection System Component Maintenance Manual

(c) Hartzell Propeller Inc. Manual 182 (61-12-82)
- Propeller Electrical De-ice Boot Removal and Installation Manual

(d) Hartzell Propeller Inc. Manual 183 (61-12-83)
- Propeller Anti-icing Boot Removal and Installation Manual

(13) Propeller ice protection system components not supplied by Hartzell Propeller Inc. are controlled by the applicable TC or STC holder's Instructions for Continued Airworthiness (ICA).

(14) Approved corrosion protection followed by approved paint must be applied to all aluminum blades. For information concerning the application of corrosion protection and paint, refer to the Maintenance Practices chapter of this manual. Operation of blades without the specified coatings and finishes, e.g., "polished blades" is not permitted.

C. Continued Airworthiness

(1) Operators are urged to keep informed of Airworthiness information via Hartzell Propeller Inc. Service Bulletins and Service Letters which are available from Hartzell Propeller Inc. distributors, or from the Hartzell Propeller Inc. factory by subscription. Selected information is also available on Hartzell Propeller Inc.'s website at www.hartzellprop.com.

D. Propeller Critical Parts

(1) The following maintenance procedures may involve propeller critical parts. These procedures have been substantiated based on Engineering analysis that expects this product will be operated and maintained using the procedures and inspections provided in the Instructions for Continued Airworthiness (ICA) for this product.

(2) Numerous propeller system parts can produce a propeller Major or Hazardous effect, even though those parts may not be considered as Critical Parts. The operating and maintenance procedures and inspections provided in the ICA for this product are, therefore, expected to be accomplished for all propeller system parts.

6. Reference Publications

The following publications contain information vital to the airworthiness of the propeller models covered in this manual:

Hartzell Propeller Inc. Manual No. 105A - Overhaul Manual

Hartzell Propeller Inc. Manual No. 110 - Overhaul Manual

Hartzell Propeller Inc. Manual No. 114B - Overhaul Manual

Hartzell Propeller Inc. Manual No. 127 (61-16-27) - Spinner Assembly Maintenance

Hartzell Propeller Inc. Manual No. 133C (61-13-33) - Aluminum Propeller Blade Maintenance Manual

Hartzell Propeller Inc. Manual No. 159 (61-02-59) - Application Guide - Also available on the Hartzell Propeller Inc. website at www.hartzellprop.com

Hartzell Propeller Inc. Manual No. 165A (61-00-65) - Illustrated Tool and Equipment Manual.

Hartzell Propeller Inc. Manual No. 180 (30-61-80) - Propeller Ice Protection System Manual - Also available on the Hartzell Propeller Inc. website at www.hartzellprop.com.

Hartzell Propeller Inc. Manual No. 181 (30-60-81) - Propeller Ice Protection System Component Maintenance Manual - Also available on the Hartzell Propeller Inc. website at www.hartzellprop.com.

Hartzell Propeller Inc. Manual No. 182 (61-12-82) - Propeller Electrical De-ice Boot Removal and Installation Manual - Also available on the Hartzell Propeller Inc. website at www.hartzellprop.com.

Hartzell Propeller Inc. Manual No. 183 (61-12-83) - Propeller Anti-icing Boot Removal and Installation Manual - Also available on the Hartzell Propeller Inc. website at www.hartzellprop.com.

Hartzell Propeller Inc. Manual No. 202A (61-01-02) - Standard Practices Manual - Volumes 1 through 11

Hartzell Propeller Inc. Service Letter HC-SL-61-61Y - Overhaul Periods and Service Life Limits for Hartzell Propeller Inc. Aviation Components - Propellers, Governors, and Propeller Damper Assemblies - Also available on the Hartzell Propeller Inc. website at www.hartzellprop.com.

7. Definitions

A basic understanding of the following terms will assist in maintaining and operating Hartzell Propeller Inc. propeller systems.

<u>Term</u>	<u>Definition</u>
Annealed	softening of material due to overexposure to heat
Blade Angle	measurement of blade airfoil location described as the angle between the blade airfoil and the surface described by propeller rotation
Brinelling.....	a depression caused by failure of the material in compression.
Chord.....	a straight line distance between the leading and trailing edges of an airfoil
Cold Rolling	compressive rolling process that provides improved strength and resistance to fatigue
Constant Force	a force that is always present in some degree when the propeller is operating
Constant Speed.....	a propeller system which employs a governing device to maintain a selected engine RPM
Corrosion	gradual material removal or deterioration due to chemical action
Crack	irregularly shaped separation within a material, sometimes visible as a narrow opening at the surface
Depression	surface area where the material has been compressed but not removed
Distortion	alteration of the original shape or size of a component

<u>Term</u>	<u>Definition</u>
Erosion	gradual wearing away or deterioration due to action of the elements
Exposure	leaving material open to action of the elements
Feathering	a propeller with blades that may be rotated to a position parallel to the relative wind, thus reducing aerodynamic drag
Gouge.....	surface area where material has been removed
Hazardous Propeller Effects.....	The hazardous propeller effects are defined in Title 14 CFR section 35.15(g)(1)
Horizontal Balance	balance between the blade tip and the center of the hub
Impact Damage	damage that occurs when the propeller blade or hub assembly strikes, or is struck by, an object while in flight or on the ground
Major Propeller Effect...	The major propeller effects are defined in Title 14 CFR section 35.15(g)(2)
Nick	removal of paint and possibly a small amount of material
Onspeed	condition in which the RPM selected by the pilot through the propeller control lever and the actual engine (propeller) RPM are equal
Overhaul.....	the periodic disassembly, inspection, repair, refinish, and reassembly of a propeller assembly to maintain airworthiness

<u>Term</u>	<u>Definition</u>
Overspeed	condition in which the RPM of the propeller or engine exceeds predetermined maximum limits; the condition in which the engine (propeller) RPM is higher than the RPM selected by the pilot through the propeller control lever
Overspeed Damage	damage that occurs when the propeller hub assembly rotates at a speed greater than the maximum limit for which it is designed
Pitch.....	same as "Blade Angle"
Pitting.....	formation of a number of small, irregularly shaped cavities in surface material caused by corrosion or wear
Propeller Critical Parts..	A part on the propeller whose primary failure can result in a hazardous propeller effect, as determined by the safety analysis required by Title 14 CFR section 35.15
Scratch	same as "Nick"
Single Acting.....	hydraulically actuated propeller which utilizes a single oil supply for pitch control
Synchronizing	adjusting the RPM of all the propellers of a multi-engine aircraft to the same RPM
Synchrophasing.....	a form of propeller synchronization in which not only the RPM of the engines (propellers) are held constant, but also the position of the propellers in relation to each other
Underspeed	the condition in which the actual engine (propeller) RPM is lower than the RPM selected by the pilot through the propeller control lever

<u>Term</u>	<u>Definition</u>
Vertical Balance.....	balance between the leading and trailing edges of a two-blade propeller, with the blades positioned vertically
Variable Force	a force which may be applied or removed during propeller operation.
Windmilling	the rotation of an aircraft propeller caused by air flowing through it while the engine is not producing power.

8. Abbreviations

<u>Abbreviation</u>	<u>Term</u>
AMM	Aircraft Maintenance Manual
AN.....	Air Force-Navy (or Army-Navy)
AOG.....	Aircraft on Ground
FAA.....	Federal Aviation Administration
FT-Lb	Foot-Pound
ICA.....	Instructions for Continued Airworthiness
ID	Inside Diameter
In-Lb	Inch-Pound
IPS.....	Inches Per Second
Lbs.....	Pounds
MIL-X-XXX.....	Military Specification
MPI	Major Periodic Inspection (Overhaul)
MS	Military Standard
MSDS	Material Safety Data Sheet
OD	Outside Diameter
NAS	National Aerospace Standards
NASM	National Aerospace Standards, Military
N•m.....	Newton-Meters
POH.....	Pilot's Operating Handbook
PSI.....	Pounds per Square Inch
RPM.....	Revolutions per Minute
TBO	Time Between Overhaul
TC.....	Type Certificate
TSN	Time Since New
TSO	Time Since Overhaul

NOTE: TSN/TSO is considered as the time accumulated between rotation and landing, i.e., flight time.

9. Hartzell Propeller Inc. Product Support

- A. Hartzell Propeller Inc. is ready to assist you with questions concerning your propeller system. Hartzell Propeller Inc. Product Support may be reached during business hours (8:00 a.m. through 5:00 p.m., United States Eastern Time) at (937) 778-4379.
- B. After business hours, you may leave a message on our 24 hour product support line at (937) 778-4376. AOG support is also available 24 hours per day, seven days per week via this message service.
- C. Additional information is available on our website at www.hartzellprop.com

NOTE: When calling from outside the United States, dial (001) before dialing the above telephone numbers.

10. Warranty Service

- A. If you believe you have a warranty claim, it is necessary to contact Hartzell's Warranty Administrator. Hartzell Propeller Inc.'s Warranty Administrator will provide you with a *Warranty Application* form. It is necessary to complete this form and return it to the Warranty Administrator for evaluation **before proceeding with repair or inspection work**. Upon receipt of this form, the Warranty Administrator will provide instructions on how to proceed. Hartzell Propeller Inc. Warranty may be reached during business hours (8:00 a.m. through 5:00 p.m.), United States Eastern Time) at (937)-778-4379 or toll free from the United States and Canada at (800) 942-7767. Hartzell Propeller Inc. Warranty Administration can also be reached by fax at (937) 778-4391, or by e-mail at warranty@hartzellprop.com.

NOTE: When calling from outside the United States, dial (001) before dialing the above telephone numbers.

11. Hartzell Propeller Inc. Recommended Facilities

- A. Hartzell Propeller Inc. recommends using Hartzell Propeller Inc. approved distributors and repair facilities for the purchase, repair and overhaul of Hartzell Propeller Inc. propeller assemblies or components.
- B. Information about the Hartzell Propeller Inc. worldwide network of aftermarket distributors and approved repair facilities is available on the Hartzell Propeller Inc. web site at www.hartzellprop.com.

(This page is intentionally blank.)

INSTALLATION AND REMOVAL - CONTENTS

1. Tools, Consumables, and Expendables	3-5
A. Tooling	3-5
B. Consumables.....	3-5
C. Expendables.....	3-5
2. O-ring and Propeller Mounting Hardware Identification.....	3-6
3. Pre-Installation.....	3-10
A. Inspection of Shipping Package	3-10
B. Uncrating	3-10
C. Inspection after Shipment.....	3-10
D. Reassembly of a Propeller Disassembled for Shipment ..	3-10
4. Propeller Assembly Installation.....	3-11
A. Precautions.....	3-11
B. O-ring and Propeller Mounting Hardware Identification....	3-12
C. Installing the F Flange Propeller Models BHC-92()F-1D1.....	3-14
D. Installing the F Flange Propeller Models HC-92()F-8()	3-22
E. Installing the K Flange Propeller Models HC-92()K-1D and HC-92()K-8()	3-28
F. Installing the F Flange Propeller Models HC-92ZF-2() and HC-93ZF-2()	3-34
G. Installing the K Flange Propeller Models HC-92()K-2()	3-40
H. Installing the F Flange Propeller Models (B)HC-92()F-3	3-45
I. Installing the F Flange Propeller Models BHC-92(W,Z)F-3(L)G	3-57
J. Installing the F Flange Propeller Model HC-92WF-5A	3-65
K. Installing the 20 Spline HC-93Z20-1() Propeller Models	3-74
L. Installing the 20 Spline HC-93Z20-2() and the 30 Spline HC-93Z30-2() Propeller Models	3-81

INSTALLATION AND REMOVAL - CONTENTS (continued)

5. Post-Installation Checks	3-96
6. Propeller Assembly Removal.....	3-97
A. Removing the F Flange Propeller Models BHC-92()F-1D1.....	3-97
B. Removing the F Flange Propeller Models HC-92()F-8()	3-99
C. Removing the K Flange Propeller Models HC-92()K-1D and HC-92()K-8()	3-102
D. Removing the F Flange Propeller Models HC-92ZF-2() and HC-93ZF-2()	3-105
E. Removing the K Flange Propeller Models HC-92()K-2()	3-108
F. Removing the F Flange Propeller Models (B)HC-92()F-3	3-112
G. Removing the F Flange Propeller Models BHC-92(W,Z)F-3(L)G	3-116
H. Removing the F Flange Propeller Model HC-92WF-5A	3-120
I. Removing the 20 Spline Propeller Models HC-93Z20-1()	3-125
J. Removing the 20 Spline HC-93Z20-2() and the 30 Spline HC-93Z30-2() Propeller Models	3-128

LIST OF FIGURES

BHC-92()F-1D1 Propeller Assembly.....	Figure 3-1.....	3-13
Installing F Flange Propeller on the Engine Flange.....	Figure 3-2.....	3-15
Determining Torque Value When Using Torquing Adapter.....	Figure 3-3.....	3-16
HC-92()()-1D,-8() Propeller Assembly	Figure 3-4.....	3-21
K Flange Installation on -1 Propeller Models. Figure 3-5.....		3-25
Installing K Flange Propeller on the Engine Flange.....	Figure 3-6.....	3-27
HC-92ZF-2(), HC-92()K-2() Propeller Assembly	Figure 3-7.....	3-32
HC-93ZF-2() Propeller Assembly	Figure 3-8.....	3-33
K Flange Installation on -2 Propeller Models. Figure 3-9.....		3-39
(B)HC-92()F-3 Propeller Assembly.....	Figure 3-10.....	3-46
Tool for Decompressing External Beta System.....	Figure 3-11.....	3-47
HC-92WF-3 Installation on TSIO-520-C Engine.....	Figure 3-12.....	3-47
Installation of Beta Valve, Governor, and Linkage	Figure 3-13.....	3-49
Carbon Block and Beta Ring Clearance.....	Figure 3-14.....	3-50
Carbon Block Assembly.....	Figure 3-15.....	3-50
Adjusting Propeller Reverse Control System	Figure 3-16.....	3-53
BHC-92(W,Z)F-3(L)G Propeller Assembly.....	Figure 3-17.....	3-59
BHC-92(W,Z)F-3(L)G Installation	Figure 3-18.....	3-60
HC- 92WF-5A Propeller Assembly	Figure 3-19.....	3-66
HC-92WF-5A Installation	Figure 3-20.....	3-68
HC-93Z20-1() Propeller Assembly.....	Figure 3-21.....	3-76
Installing Piston O-ring and Felt Dust Seal....	Figure 3-22.....	3-78
HC-93Z20-2A(1), -2B, -2C, -2D1 Propeller Assembly	Figure 3-23.....	3-83
HC-93Z20-2C1 Propeller Assembly	Figure 3-24.....	3-84
HC-93Z30-2E Propeller Assembly.....	Figure 3-25.....	3-85
Piston-to-Link Arm Attachment Details	Figure 3-26.....	3-87
Spring Assembly-to-Cylinder Attachment Details	Figure 3-27.....	3-89
Feathering Spring Assembly.....	Figure 3-28.....	3-90
Rear Hub Mounting Parts on 30-Spline Shaft Propeller	Figure 3-29.....	3-91

LIST OF FIGURES (continued)

Safelying the Shaft Nut on a Splined Shaft Propeller	Figure 3-30.....	3-93
Reversing (Beta) System and Governing Hardware	Figure 3-31	3-114
Disconnecting the Beta Ring	Figure 3-32.....	3-121

LIST OF TABLES

O-ring and Propeller Mounting Hardware Identification	Table 3-1	3-6
Torque Values Table	Table 3-2	3-17

1. Tools, Consumables, and Expendables

The steel hub reciprocating propellers covered in this manual are manufactured with either a flange mounting or a spline mounting. The flange type or spline type used on a particular propeller installation is indicated in the propeller model identification number stamped on the hub. For example, HC-92W**K**-2B indicates a "K" flange. HC-93Z**20**-2A indicates a "20" spline. Refer to the Steel Hub Model Identification in the Description and Operation chapter of this manual for a description of each flange type.

The flange mounted propeller is shipped completely assembled. The spline mounted propeller is shipped with the piston removed.

The following tools, consumables, and expendables will be required for propeller removal or installation:

A. Tooling

F Flange

- Safety wire pliers (Alternate: Safety cable tool)
- Torque wrench
- Torque wrench adapter (Hartzell Propeller Inc. P/N AST-2814)

K Flange

- Safety wire pliers (Alternate: Safety cable tool)
- Torque wrench
- Torque wrench adapter (Hartzell Propeller Inc. P/N AST-2805)

20 Spline

- Safety wire pliers
- Shaft nut wrench (Hartzell Propeller Inc. P/N BST-2910)

30 Spline

- Safety wire pliers
- Spanner wrench (Hartzell Propeller Inc. P/N BT461) or Strap Wrench (P/N 100923)
- Shaft nut wrench (Hartzell Propeller Inc. P/N BST-2910)

B. Consumables

- Quick Dry Stoddard Solvent or Methyl-Ethyl-Ketone (MEK)

C. Expendables

- 0.032 inch (0.81 mm) Stainless Steel Aircraft Safety wire (Alternate: 0.032 inch [0.81 mm] aircraft safety cable and associated hardware)
- O-ring Propeller to engine seal - Refer to Table 3-1.

2. O-ring and Propeller Mounting Hardware Identification

Part	Propeller Model	Part No.	
Bolt/Stud, Mounting	HC-92WK-2()	A-1328-2 (4) or A-1333 (2)	
	HC-92ZF-2()	A-1333-4	
	HC-92ZK-2(A)()	A-1328 (4) or A-1315 (2)	
	HC-92ZK-2B	A-1328 (4) or A-1333 (2)	
	HC-93ZF-2()	B-6739H7A	
	HC-92()K-1D	* NOTE	
	BHC-92()F-1D1	A-1328-2	
	HC-92WF-8()	A-1333-4	
	HC-92()K-8()	* NOTE	
	HC-92ZF-8D	A-1333-4	
	(B)HC-92()F-3	A-1328-1	
	BHC-92()F-3(L)G	A-2986	
	BHC-92WF-5A	A-1328-1	
	Dowel Pins	HC-92ZF-2()	B-6138-8-8
		HC-93ZF-2()	B-6138-8-8
HC-92()F-8()		B-6138-8-8	
(B)HC-92()F-1D1		B-1344 or B-6138-8-8	
(B)HC-92()F-3		B-6138-8-8	
BHC-92WF-3(L)G		B-6138-8-9 or B-6138-8-10	
HC-92WF-5A		B-6138-8-8	
Felt Dust Seal	(B)HC-92()F-1D1	B-1843	
	HC-93Z20-1()()	B-1843	
	HC-93Z20-2()()	B-1843	
	HC-93Z30-2E	B-1843	
Gasket, Governor (Governor and Beta Valve)	HC-93Z30-2B	A-810	
	(B)HC-92()F-3 BHC-92(W,F)-3(L)G HC-92WF-5A	B-1104-()	
Nut, Fork Rod	HC-92()(F,K)-8()	A-848 or A-848-2	
	HC-92()K-1D	A-848 or A-848-2	
	(B)HC-92WF-1D1	A-848-2	
	HC-93Z20-1(A,B,C)(1)	A-848-2	
* NOTE: (2) A-1333 + (2) A-1333-3 or A-1333 (under lugs of collar) + (2) A-1333-6 or A-1333-2 (under rods of piston)			

**O-ring and Propeller Mounting Hardware Identification
Table 3-1**

Part	Propeller Model	Part No.
Nut, Governor (Governor and Beta Valve)	(B)HC-92()F-3 BHC-92(W,F)-3(L)G HC-92WF-5A	B-3808-5
Nut, Piston Rod	HC-93Z20-2()(1) HC-93Z30-2() HC-93ZF-2()	B-3368 B-3368 B-3368
Nut, Pitch change rod	HC-92Z()-2()(L) HC-93Z20-2()(1) HC-93Z30-2() HC-93ZF-2A HC-93ZF-2B (B)HC-92()F-3 BHC-92WF-3(L)G HC-92WF-5A	A-880-2 A-880-1 A-880-1 A-880-2 A-880-1 A-880-2 A-880-2 A-880-2
Nut, Shaft/Hub	HC-93Z20-2()(1) HC-93Z20-1()(1) HC-93Z30-2()	A-63-B A-63-B B-1814
Nut, Castle (Mounting Stud)	HC-92WF-3	A-2069-2
Nut Lock, Shaft	HC-93Z30-2(B,C) HC-93Z30-2E	A-1839 A-1839-1
O-ring, Bushing	HC-B3Z30-2E	C-3317-210-1
O-ring, Piston	(BHC)-92()F-1D1 HC-93Z20-2()(1) HC-93Z20-1()(1) HC-93Z30-2B HC-93Z30-2E	C-3317-343-1 C-3317-343-1 C-3317-343-1 C-3317-343-1 C-3317-347-1
O-ring, Pitch change rod	HC-92()(F,K)-2()(L) HC-93Z20-2(A,B,D)(1) HC-93Z20-2C1 HC-93Z30-2() HC-93ZF-2(A,B) (B)HC-92()F-3 BHC-92()F-3(L)G HC-92WF-5A	C-3317-024 C-3317-116 C-3317-020 C-3317-020 C-3317-343-1 C-3317-024 C-3317-024 C-3317-230
O-ring, Rear Cone	HC-93Z20-2()(1) HC-93Z20-1()(1) HC-93Z30-2()	C-3317-229 C-3317-229 C-3317-111

**O-ring and Propeller Mounting Hardware Identification
Table 3-1, Continued**

Part	Propeller Model	Part No.
O-ring, Shaft	HC-92()K-2()(L)	C-3317-329
	HC-92ZF-2(A,B)	C-3317-228
	HC-92WF-8()	C-3317-228
	HC-92WK-8()	C-3317-329
	HC-92()K-1D	C-3317-329
	HC-92ZF-8D	C-3317-228
	HC-92ZK-8()	C-3317-329
	(B)HC-92()F-1D1	C-3317-228
	HC-93ZF-2(A,B)	C-3317-228
	(B)HC-92()F-3	C-3317-228
	BHC-92()F-3(L)G	C-3317-228
	HC-92WF-5A	C-3317-228
	Safety Pin	HC-93Z20-2()(1)
HC-93Z20-1()(1)		A-847
Screw, Piston Rod	HC-93Z20-2()(1)	A-2037
	HC-93Z30-2()	A-2037
Shim	HC-92()K-2()(L)	B-1322
	HC-92()K-1D	B-1322
	HC-92()K-8()	B-1322
Spacer	HC-93Z30-2()	A-1819
	(B)HC-92()F-3G(L)	C-2987
Spinner Mounting Plate	(B)HC-92WF-1D1	B-1344
Stud, Governor (Governor and Beta Valve)	(B)HC-92()F-3	A-3147
	BHC-92(W,F)-3(L)G	
	HC-92WF-5A	
Washer, Fork Rod	HC-92()F,K-8()	A-965
	HC-92()K-1D	A-965
	(B)HC-92WF-1D1	A-965
	HC-93Z20-1()(1)	A-965

**O-ring and Propeller Mounting Hardware Identification
Table 3-1, Continued**

Part	Propeller Model	Part No.
Washer, Mounting	HC-92ZF-2() HC-92WF-8() HC-92ZF-8D (B)HC-92()F-3 BHC-92()F-3(L)G BHC-92WF-5A HC-92(W,Z)K-2 (located at counter- bore under blade)	B-3851-0863 B-3851-0863 or A-1381 B-3851-0863 or A-1381 A-1381 A-1381 A-1381 A-946
Washer, Piston Rod	HC-93Z20-2()(1) HC-93Z30-2()	A-1444 A-1444

**O-ring and Propeller Mounting Hardware Identification
Table 3-1, Continued**

3. Pre-Installation**A. Inspection of Shipping Package**

- (1) Examine the exterior of the shipping container for signs of shipping damage, especially the box ends around each blade. A hole, tear, or crushed appearance at the end of the box (blade tips) may indicate that the propeller was dropped during shipment, possibly damaging the blades.

B. Uncrating

- (1) Place the propeller on a firm support.
- (2) Remove the banding and any external wood bracing from the shipping container.
- (3) Remove the cardboard from the hub and blades.

CAUTION: DO NOT STAND THE PROPELLER ON A BLADE TIP.

- (4) Place the propeller on a padded surface that supports the propeller over a large area. Never stand the propeller on a blade tip.
- (5) On flange mounted models, remove the plastic dust cover cup from the propeller mounting flange (if installed).

C. Inspection after Shipment

- (1) After removing the propeller from the shipping container, examine the propeller components for shipping damage.

D. Reassembly of a Propeller Disassembled for Shipment

- (1) If a propeller was received disassembled for shipment, it must be reassembled by trained personnel in accordance with the applicable propeller maintenance manual.

4. Propeller Assembly Installation**A. Precautions**

WARNING 1: DURING ENGINE INSTALLATION OR REMOVAL, USING THE PROPELLER TO SUPPORT THE WEIGHT OF THE ENGINE IS NOT AUTHORIZED. UNAPPROVED INSTALLATION AND REMOVAL TECHNIQUES MAY CAUSE DAMAGE TO THE PROPELLER THAT MAY LEAD TO FAILURE RESULTING IN AN AIRCRAFT ACCIDENT.

WARNING 2: WHEN INSTALLING THE PROPELLER, FOLLOW THE AIRFRAME MANUFACTURER'S MANUALS AND PROCEDURES, AS THEY MAY CONTAIN ISSUES VITAL TO AIRCRAFT SAFETY THAT ARE NOT CONTAINED IN THIS OWNER'S MANUAL.

CAUTION: INSTRUCTIONS AND PROCEDURES IN THIS SECTION MAY INVOLVE PROPELLER CRITICAL PARTS. REFER TO THE INTRODUCTION CHAPTER OF THIS MANUAL FOR INFORMATION ABOUT PROPELLER CRITICAL PARTS.

- (1) Be sure the propeller is removed before the engine is removed or installed in the airframe.
- (2) Follow the airframe manufacturer's instructions for installing the propeller. If such instructions are not in the airframe manufacturer's manual, then follow the instructions in this manual; however, mechanics must consider that this owner's manual does not describe important procedures that are outside its scope. In addition to propeller installation procedures, items such as rigging and preflight testing, installation and adjustment of de-ice equipment, and propeller synchronization devices are normally found in the airframe manufacturer's manuals.

B. O-ring and Propeller Mounting Hardware Identification

- (1) Refer to Table 3-1 for specific part numbers of O-rings and propeller mounting hardware, and propeller model effectivity.

D-1340

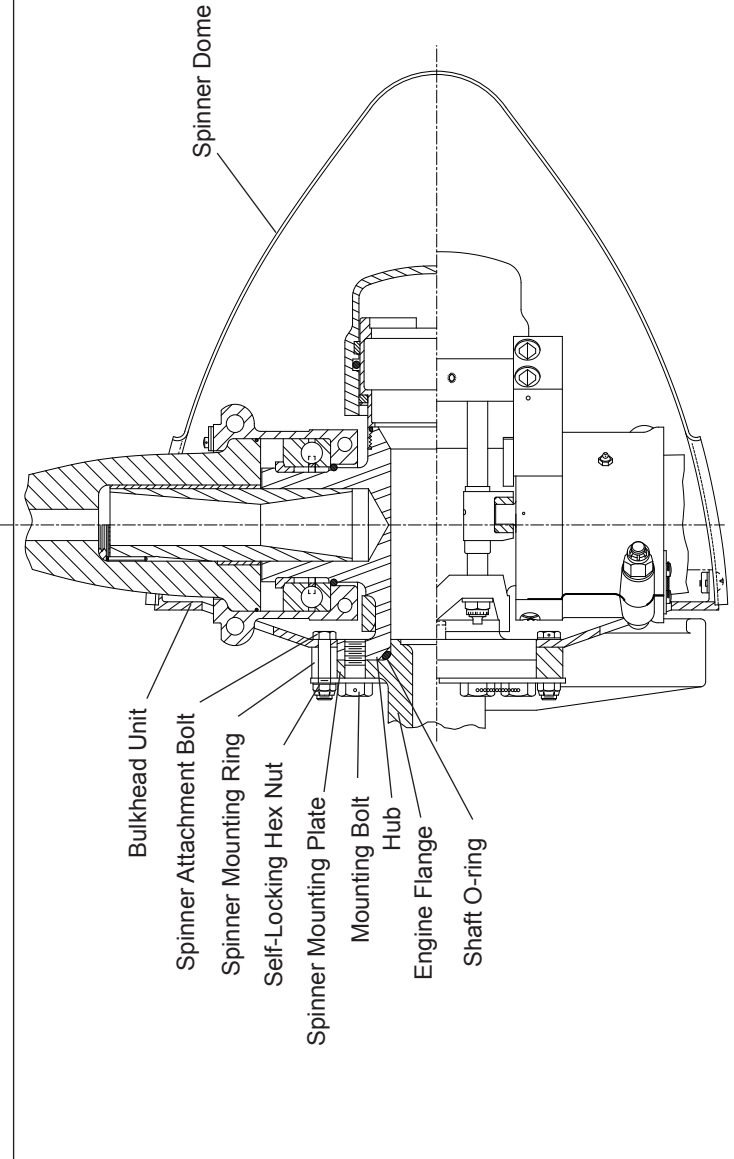

BHC-92()F-1D1 Propeller Assembly
Figure 3-1

- C. Installing the F Flange Propeller Models BHC-92()F-1D1
Refer to Figure 3-1.

WARNING: MAKE SURE THE SLING IS RATED UP TO 800 LBS. (363 KG) TO SUPPORT THE WEIGHT OF THE PROPELLER ASSEMBLY DURING INSTALLATION.

CAUTION 1: INSTRUCTIONS AND PROCEDURES IN THIS SECTION MAY INVOLVE PROPELLER CRITICAL PARTS. REFER TO THE INTRODUCTION CHAPTER OF THIS MANUAL FOR INFORMATION ABOUT PROPELLER CRITICAL PARTS.

CAUTION 2: WHEN INSTALLING THE PROPELLER ON THE AIRCRAFT, DO NOT DAMAGE THE ICE PROTECTION SYSTEM COMPONENTS, IF APPLICABLE.

- (1) With a suitable crane hoist and sling, carefully move the propeller assembly to the aircraft engine mounting flange in preparation for installation.

WARNING: ADHESIVES AND SOLVENTS ARE FLAMMABLE AND TOXIC TO THE SKIN, EYES, AND RESPIRATORY TRACT. SKIN AND EYE PROTECTION ARE REQUIRED. AVOID PROLONGED CONTACT AND BREATHING OF VAPORS. USE SOLVENT RESISTANT GLOVES TO MINIMIZE SKIN CONTACT AND WEAR SAFETY GLASSES FOR EYE PROTECTION. USE IN A WELL VENTILATED AREA AWAY FROM SPARKS AND FLAME. READ AND OBSERVE ALL WARNING LABELS.

- (2) Clean the engine flange and propeller flange with Quick Dry Stoddard Solvent or MEK.
- (3) Press fit two dowel pins through the holes in the propeller flange to be flush with the propeller side of the hub flange. Refer to Table 3-1.
- (4) Install the specified shaft O-ring on the engine shaft. Refer to Table 3-1.

D-2999F
TORQUE.PLT

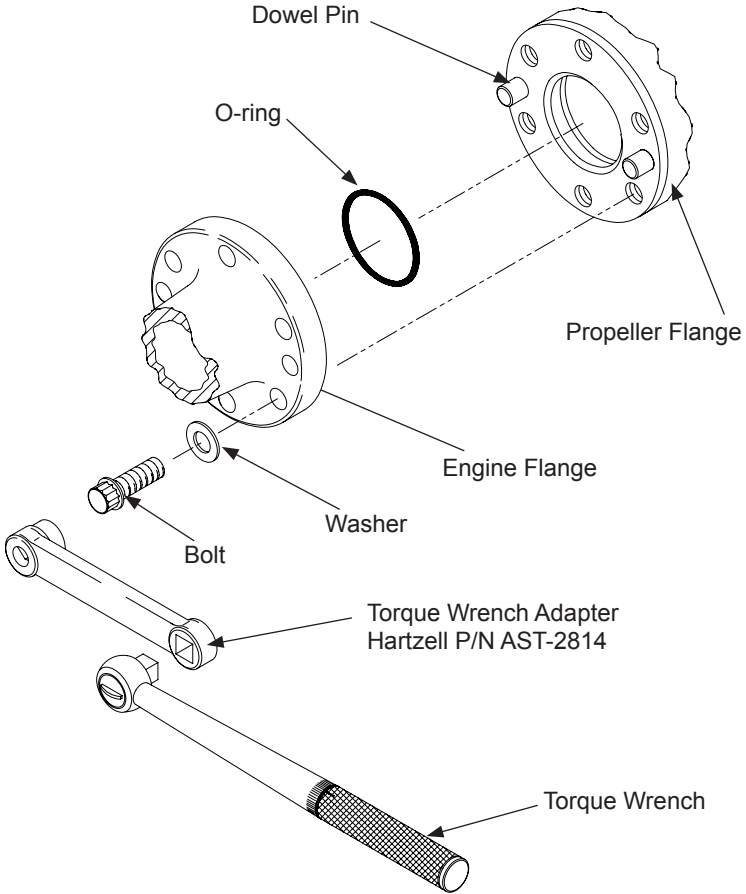

NOTE: If torque wrench adapter is used, use the calculation in Table 3-1 to determine correct torque wrench setting.

**Installing F Flange Propeller on the Engine Flange
Figure 3-2**

- (5) Slide the spinner mounting ring onto the engine flange OD.

CAUTION: USE CARE TO AVOID SCRAPING ALUMINUM FROM THE BORE OF THE RING. SCRAPINGS COULD BECOME WEDGED BETWEEN THE FLANGE SURFACES.

- (6) Align the spinner bulkhead mounting holes with the ring (on the propeller side of the ring).
- (7) Align the spinner mounting plate with the ring (on the engine side of the ring).
- (8) Install the spinner attachment bolts and self-locking hex head nuts to hold the spinner bulkhead, spinner mounting ring, and spinner mounting plate together.
- (9) Torque the spinner attachment bolts and self-locking hex head nuts to 8 to 12 Ft-Lb (10-16 N•m).

APS0212A

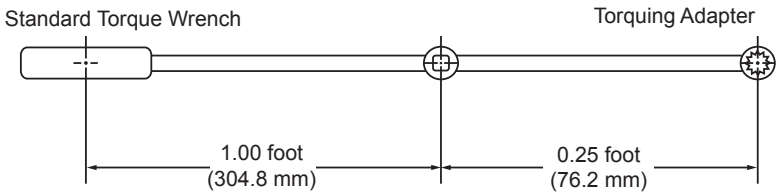

$$\frac{(\text{actual torque required}) \times (\text{torque wrench length})}{(\text{torque wrench length}) + (\text{length of adapter})} = \text{Torque wrench reading to achieve required actual torque}$$

EXAMPLE:

$$\frac{100 \text{ Ft-Lb (136 N}\cdot\text{m)} \times 1 \text{ ft (304.8 mm)}}{1 \text{ ft (304.8 mm)} + 0.25 \text{ ft (76.2 mm)}} = 80 \text{ Ft-Lb (108 N}\cdot\text{m)} < \text{reading on torque wrench with 3-inch (76.2 mm) adapter for actual torque of 100 Ft-Lb (136 N}\cdot\text{m)}$$

The correction shown is for an adapter that is aligned with the centerline of the torque wrench. If the adapter is angled 90 degrees relative to the torque wrench centerline, the torque wrench reading and actual torque applied will be equal.

Determining Torque Value When Using Torquing Adapter Figure 3-3

<u>Propeller Model</u>	<u>Mounting Bolt</u>	<u>Torque</u>
HC-92WK-1D **	A-1333	70-80 Ft-Lb (81-95 N•m)*
HC-92ZK-1D	A-1333	70-80 Ft-Lb (81-95 N•m)*
BHC-92WF-1D1	A-1328-2	70-80 Ft-Lb (81-95 N•m)*
BHC-92ZF-1D1	A-1328-2	70-80 Ft-Lb (81-95 N•m)*
HC-92ZF-1D1	A-1328-2	70-80 Ft-Lb (81-95 N•m)*
HC-92WK-2, -2B	A-1328 and A-1333	70-80 Ft-Lb (81-95 N•m)*
HC-92ZK-2, -2A, -2AL, -2B	A-1328 and A-1333	70-80 Ft-Lb (81-95 N•m)*
HC-92ZF-2A, -2B	A-1333-4	70-80 Ft-Lb (81-95 N•m)*
BHC-92WF-3	A-1328-1 or A-1333-4	70-80 Ft-Lb (81-95 N•m)*
BHC-92ZF-3	A-1328-1 or A-1333-4	70-80 Ft-Lb (81-95 N•m)*
HC-92WF-3	A-1328-1 or A-1333-4	70-80 Ft-Lb (81-95 N•m)*
HC-92ZF-3	A-1328-1 or A-1333-4	70-80 Ft-Lb (81-95 N•m)*
BHC-92WF-3G, -3LG	A-2069-2 Stud Nut	90 Ft-Lb (122 N•m)*
BHC-92ZF-3LG	A-2069-2 Stud Nut	90 Ft-Lb (122 N•m)*
HC-92WF-5A	A-1328-1 or A-1333-4	70-80 Ft-Lb (81-95 N•m)*
HC-92WF-8D, -8E	A-1333-4	70-80 Ft-Lb (81-95 N•m)*
HC-92ZF-8D	A-1333-4	70-80 Ft-Lb (81-95 N•m)*
HC-92WK-8D	A-1333	70-80 Ft-Lb (81-95 N•m)*
HC-92ZK-8D	A-1333	70-80 Ft-Lb (81-95 N•m)*
HC-92WK-8L	A-1333	70-80 Ft-Lb (81-95 N•m)*
HC-92ZK-8L	A-1333	70-80 Ft-Lb (81-95 N•m)*
HC-93ZF-2A, -2B	A-1328	70-80 Ft-Lb (81-95 N•m)*

**Torque Values Table
Table 3-2**

<u>Propeller Model</u>	<u>Mounting Bolt</u>	<u>Torque</u>
HC-93Z20-2A, -2A1	A-63B Hub Nut	450 Ft-Lb (610 N•m)*
HC-93Z20-2C	A-63B Hub Nut	450 Ft-Lb (610 N•m)*
HC-93Z20-2D1	A-63B or B-2063 Nut	450 Ft-Lb (610 N•m)*
HC-93Z20-1A	A-63B or B-2063 Nut	450 Ft-Lb (610 N•m)*
HC-93Z20-1A1	A-63B or B-2063 Nut	450 Ft-Lb (610 N•m)*
HC-93Z20-1B1	A-63B or B-2063 Nut	450 Ft-Lb (610 N•m)*
HC-93Z20-2C1	A-63B Shaft Nut	450 Ft-Lb (610 N•m)*
HC-93Z30-2B, -2E	B-1814 Nut	600 Ft-Lb (813 N•m)*
Spinner mounting bolts		30-40 Ft-Lb (41-54 N•m)*
Piston Nut	A-880-1	120 Ft-Lb (163 N•m)*
Low-pitch stop nut	A-848 A-848-2	20-22 Ft-Lb (27-30 N•m)*

* Torque tolerance is ± 10 percent unless otherwise noted.

** Exceptions to torque values listed in above chart: HC-92WK-1D when installed on a Found Bros. Centennial 100 or Technoimport - Torque = 80-90 Ft-Lb (108-122 N•m)*

NOTE 1: Torque values are based on non-lubricated threads.

NOTE 2: **Specified torques take into account the run on torque of the fasteners. No adjustment of the specified torque is required to allow for run on torque.**

Torque Values Table
Table 3-2, Continued

- (10) Align the mounting holes and dowel pins in the propeller hub flange with the mounting holes and the dowel pin holes in the engine flange.

CAUTION: MAKE SURE THAT COMPLETE AND TRUE SURFACE CONTACT IS ESTABLISHED BETWEEN THE PROPELLER HUB FLANGE AND THE ENGINE FLANGE.

- (11) Slide the propeller flange onto the engine flange.

- (12) Align the spinner mounting plate clearance holes with the engine flange clearance holes.

CAUTION: NEW PROPELLER MOUNTING BOLTS MUST BE USED WHEN INITIALLY INSTALLING A NEW OR OVERHAULED PROPELLER.

- (13) Install the mounting bolts with washers (if applicable) through the spinner mounting plate and the engine flange from the rear and into the tapped holes in the propeller flange. Refer to Table 3-1 and Figure 3-1.

NOTE: For propeller removals between overhaul intervals, mounting bolts and washers may be reused if they are not damaged or corroded.

- (14) Use a torque wrench with a torque wrench adapter Hartzell Propeller Inc. P/N AST-2814 to torque all mounting bolts in sequence in accordance with Table 3-2, Torque Values Table, Figure 3-2, and Figure 3-3 to determine the proper torque value to which the torque wrench must be set.

(a) Torque the mounting bolts to half of the final torque, beginning with any mounting bolt, and moving clockwise or counterclockwise until all the bolts are torqued.

(b) Final torque the bolts in sequence, beginning with any mounting bolt, and moving clockwise or counterclockwise until all the bolts are torqued.

- (15) Safety all mounting bolts with 0.032 inch (0.81 mm) minimum diameter stainless steel wire or equivalent aircraft safety cable and associated hardware (two bolts per safety).

(16) If the propeller is equipped with an ice protection system that uses components supplied by Hartzell Propeller Inc., applicable instructions and technical information for the components supplied by Hartzell Propeller Inc. can be found in the following publications available on the Hartzell Propeller Inc. web site at www.hartzellprop.com.

- (a) Hartzell Propeller Inc. Manual 180 (30-61-80)
- Propeller Ice Protection System Manual
- (b) Hartzell Propeller Inc. Manual 181 (30-60-81)
- Propeller Ice Protection System Component Maintenance Manual
- (c) Hartzell Propeller Inc. Manual 182 (61-12-82)
- Propeller Electrical De-ice Boot Removal and Installation Manual
- (d) Hartzell Propeller Inc. Manual 183 (61-12-83)
- Propeller Anti-icing Boot Removal and Installation Manual

(17) Propeller ice protection system components not supplied by Hartzell Propeller Inc. are controlled by the applicable TC or STC holder's Instructions for Continued Airworthiness (ICA).

(18) Install the spinner dome as follows:

NOTE: The following instructions relate to Hartzell Propeller Inc. spinners only. In some cases, the airframe manufacturer produced the spinner assembly. In those cases, refer to the airframe manufacturer's manual for spinner installation instructions.

D-1334

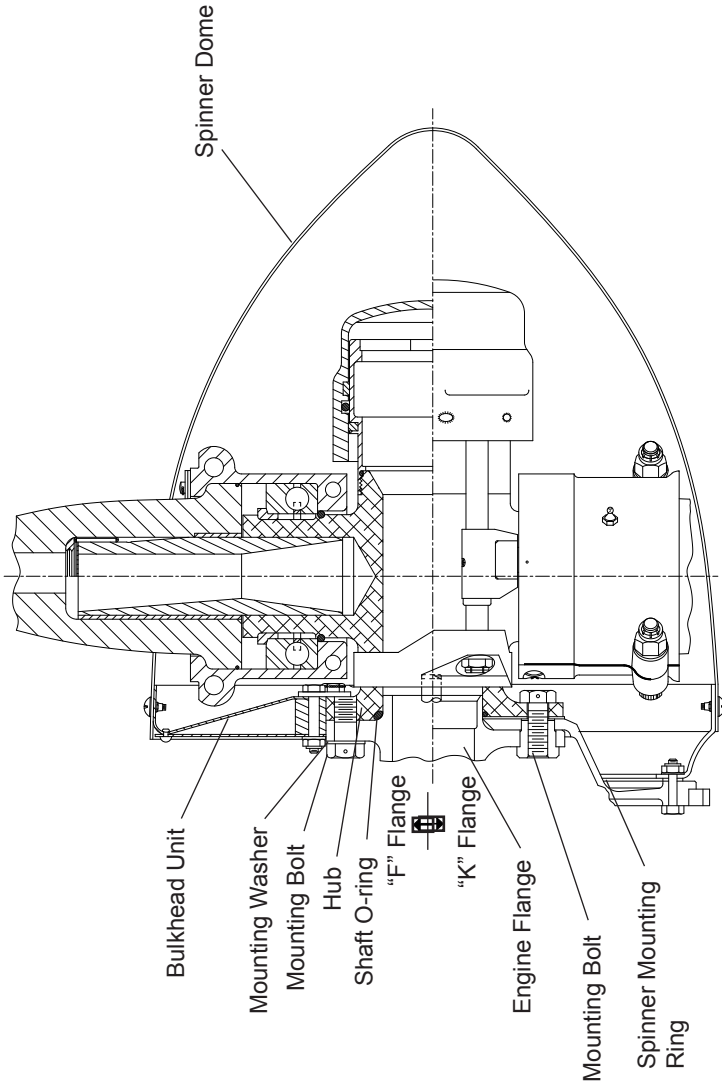

HC-92()-1D,-8() Propeller Assembly
Figure 3-4



CAUTION 1: TO PREVENT DAMAGE TO THE BLADE AND BLADE PAINT, WRAP THE BLADE SHANKS IN SEVERAL LAYERS OF MASKING OR DUCT TAPE BEFORE INSTALLING THE SPINNER DOME. REMOVE THE TAPE AFTER THE SPINNER IS INSTALLED.

CAUTION 2: THE SPINNER DOME WILL WOBBLE IF NOT ALIGNED PROPERLY, AND MAY AFFECT THE BALANCE OF THE PROPELLER.

- (a) Carefully slide the spinner dome over the reassembled propeller.
- (b) Attach the spinner dome to the spinner bulkhead with the supplied screws and washers.

D. Installing the F Flange Propeller Models HC-92()F-8()
Refer to Figure 3-4.

WARNING: MAKE SURE THE SLING IS RATED UP TO 800 LBS. (363 KG) TO SUPPORT THE WEIGHT OF THE PROPELLER ASSEMBLY DURING INSTALLATION.

CAUTION 1: INSTRUCTIONS AND PROCEDURES IN THIS SECTION MAY INVOLVE PROPELLER CRITICAL PARTS. REFER TO THE INTRODUCTION CHAPTER OF THIS MANUAL FOR INFORMATION ABOUT PROPELLER CRITICAL PARTS.

CAUTION 2: WHEN INSTALLING THE PROPELLER ON THE AIRCRAFT, DO NOT DAMAGE THE ICE PROTECTION SYSTEM COMPONENTS, IF APPLICABLE.

- (1) With a suitable crane hoist and sling, carefully move the propeller assembly to the aircraft engine mounting flange in preparation for installation.

WARNING: ADHESIVES AND SOLVENTS ARE FLAMMABLE AND TOXIC TO THE SKIN, EYES, AND RESPIRATORY TRACT. SKIN AND EYE PROTECTION ARE REQUIRED. AVOID PROLONGED CONTACT AND BREATHING OF VAPORS. USE SOLVENT RESISTANT GLOVES TO MINIMIZE SKIN CONTACT AND WEAR SAFETY GLASSES FOR EYE PROTECTION. USE IN A WELL VENTILATED AREA AWAY FROM SPARKS AND FLAME. READ AND OBSERVE ALL WARNING LABELS.

- (2) Clean the engine flange and propeller flange with Quick Dry Stoddard Solvent or MEK.
- (3) Press fit two dowel pins through the holes in the propeller flange to be flush with the propeller side of the hub flange. Refer to Table 3-1.
- (4) Install the specified shaft O-ring on the engine shaft. Refer to Table 3-1.
- (5) Align the mounting holes and dowel pins in the propeller hub flange with the mounting holes and the dowel pin holes in the engine flange.

NOTE: The spinner bulkhead is already attached to the propeller side of the propeller mounting flange.

CAUTION 1: USE CARE TO AVOID SCRAPING ALUMINUM FROM THE BORE OF THE RING. SCRAPINGS COULD BECOME WEDGED BETWEEN THE FLANGE SURFACES.

CAUTION 2: MAKE SURE THAT COMPLETE AND TRUE SURFACE CONTACT IS ESTABLISHED BETWEEN THE PROPELLER HUB FLANGE AND THE ENGINE FLANGE.

- (6) Slide the propeller flange and spinner bulkhead onto the engine flange.

CAUTION: NEW PROPELLER MOUNTING BOLTS MUST BE USED WHEN INITIALLY INSTALLING A NEW OR OVERHAULED PROPELLER.

- (7) Install the mounting bolts with mounting washers through the engine flange from the rear and into the tapped holes in the propeller flange. Refer to Table 3-1 and Figure 3-4.

NOTE: For propeller removals between overhaul intervals, mounting bolts and washers may be reused if they are not damaged or corroded.

- (8) Use a torque wrench with a torque wrench adapter Hartzell Propeller Inc. P/N AST-2814 to torque all mounting bolts in sequence in accordance with Table 3-2, Torque Values Table, Figure 3-2, and Figure 3-3 to determine the proper torque value to which the torque wrench must be set.

(a) Torque the mounting bolts to half of the final torque, beginning with any mounting bolt, and moving clockwise or counterclockwise until all the bolts are torqued.

(b) Final torque the bolts in sequence, beginning with any mounting bolt, and moving clockwise or counterclockwise until all the bolts are torqued.

- (9) Safety all mounting bolts with 0.032 inch (0.81 mm) minimum diameter stainless steel wire or equivalent aircraft safety cable and associated hardware (two bolts per safety).

- (10) If the propeller is equipped with an ice protection system that uses components supplied by Hartzell Propeller Inc., applicable instructions and technical information for the components supplied by Hartzell Propeller Inc. can be found in the following publications available on the Hartzell Propeller Inc. web site at www.hartzellprop.com.

(a) Hartzell Propeller Inc. Manual 180 (30-61-80)
- Propeller Ice Protection System Manual

(b) Hartzell Propeller Inc. Manual 181 (30-60-81)
- Propeller Ice Protection System Component Maintenance Manual

D-1334

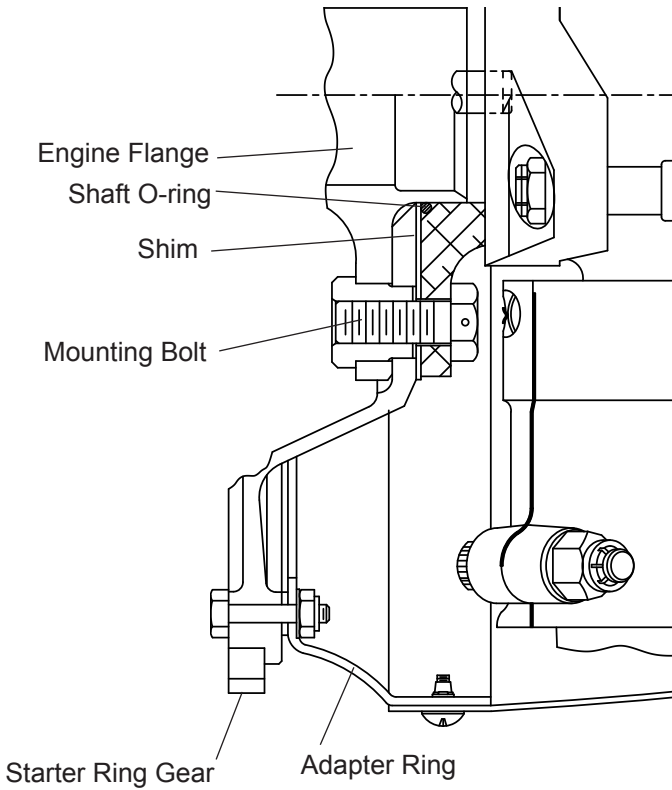

K Flange Installation on -1 Propeller Models
Figure 3-5



(c) Hartzell Propeller Inc. Manual 182 (61-12-82)
- Propeller Electrical De-ice Boot Removal and
Installation Manual

(d) Hartzell Propeller Inc. Manual 183 (61-12-83)
- Propeller Anti-icing Boot Removal and Installation
Manual

(11) Propeller ice protection system components not
supplied by Hartzell Propeller Inc. are controlled by the
applicable TC or STC holder's Instructions for Continued
Airworthiness (ICA).

(12) Install the spinner dome as follows:

CAUTION 1: TO PREVENT DAMAGE TO THE
BLADE AND BLADE PAINT, WRAP
THE BLADE SHANKS IN SEVERAL
LAYERS OF MASKING OR DUCT TAPE
BEFORE INSTALLING THE SPINNER
DOME. REMOVE THE TAPE AFTER
THE SPINNER IS INSTALLED.

CAUTION 2: THE SPINNER DOME WILL WOBBLE
IF NOT ALIGNED PROPERLY, AND
MAY AFFECT THE BALANCE OF THE
PROPELLER.

NOTE: The following instructions relate to Hartzell
Propeller Inc. spinners only. In some cases,
the airframe manufacturer produced the
spinner assembly. In those cases, refer to the
airframe manufacturer's manual for spinner
installation instructions.

(a) Carefully slide the spinner dome over the
reassembled propeller.

(b) Secure the spinner dome to the spinner bulkhead
with the supplied screws and washers.

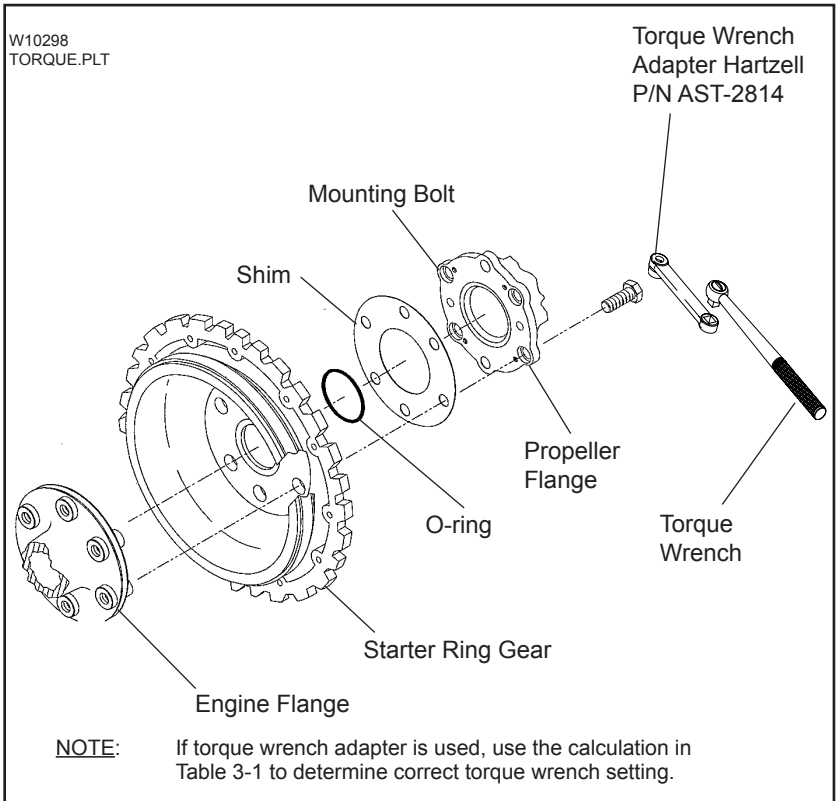

**Installing K Flange Propeller on the Engine Flange
Figure 3-6**



- E. Installing the K Flange Propeller Models HC-92()K-1D and HC-92()K-8()

Refer to Figure 3-4.

WARNING: MAKE SURE THE SLING IS RATED UP TO 800 LBS. (363 KG) TO SUPPORT THE WEIGHT OF THE PROPELLER ASSEMBLY DURING INSTALLATION.

CAUTION 1: INSTRUCTIONS AND PROCEDURES IN THIS SECTION MAY INVOLVE PROPELLER CRITICAL PARTS. REFER TO THE INTRODUCTION CHAPTER OF THIS MANUAL FOR INFORMATION ABOUT PROPELLER CRITICAL PARTS.

CAUTION 2: WHEN INSTALLING THE PROPELLER ON THE AIRCRAFT, DO NOT DAMAGE THE ICE PROTECTION SYSTEM COMPONENTS, IF APPLICABLE.

- (1) With a suitable crane hoist and sling, carefully move the propeller assembly to the aircraft engine mounting flange in preparation for installation.

WARNING: ADHESIVES AND SOLVENTS ARE FLAMMABLE AND TOXIC TO THE SKIN, EYES, AND RESPIRATORY TRACT. SKIN AND EYE PROTECTION ARE REQUIRED. AVOID PROLONGED CONTACT AND BREATHING OF VAPORS. USE SOLVENT RESISTANT GLOVES TO MINIMIZE SKIN CONTACT AND WEAR SAFETY GLASSES FOR EYE PROTECTION. USE IN A WELL VENTILATED AREA AWAY FROM SPARKS AND FLAME. READ AND OBSERVE ALL WARNING LABELS.

- (2) Clean the engine flange and propeller flange with Quick Dry Stoddard Solvent or MEK.
- (3) Install the spinner adapter ring on the engine starter gear. Refer to Figure 3-5.

CAUTION: FAILURE TO INSTALL THE SHIM BETWEEN THE PROPELLER FLANGE AND THE STARTER RING GEAR CAN RESULT IN MOUNTING BOLT FAILURE.

- (4) Install the shim on the engine shaft, between the starter ring gear and the propeller flange. Refer to Figure 3-5.
- (5) Install the specified shaft O-ring on the engine shaft. Refer to Figure 3-5.
- (6) Align the six mounting bolts in the propeller hub flange with the bushings in the engine flange.

NOTE 1: The propeller mounting bolts will already be installed in the propeller flange. Interference with other propeller parts requires that the bolts be installed during propeller assembly.

NOTE 2: For propeller removals between overhaul intervals, mounting bolts and washers may be reused if they are not damaged or corroded.

CAUTION: MAKE SURE THAT COMPLETE AND TRUE SURFACE CONTACT IS ESTABLISHED BETWEEN THE PROPELLER HUB FLANGE AND THE ENGINE FLANGE.

- (7) Slide the propeller flange onto the engine flange, against the starter ring gear.

NOTE: The engine bushings will insert into the counterbores in the propeller flange that encircles the propeller mounting bolts.

CAUTION: NEW PROPELLER MOUNTING BOLTS MUST BE USED WHEN INITIALLY INSTALLING A NEW OR OVERHAULED PROPELLER.

- (8) Use a torque wrench with a torque wrench adapter Hartzell Propeller Inc. P/N AST-2814 to torque all mounting bolts in sequence in accordance with Table 3-2, Torque Values Table, Figure 3-6, and Figure 3-3 to determine the proper torque value to which the torque wrench must be set.

- (a) Torque the mounting bolts to half of the final torque, beginning with any mounting bolt, and moving clockwise or counterclockwise until all the bolts are torqued.
 - (b) Final torque the bolts in sequence, beginning with any mounting bolt, and moving clockwise or counterclockwise until all the bolts are torqued.
- (9) Safety all mounting bolts with 0.032 inch (0.81 mm) minimum diameter stainless steel wire or equivalent aircraft safety cable and associated hardware (two bolts per safety).
- (10) If the propeller is equipped with an ice protection system that uses components supplied by Hartzell Propeller Inc., applicable instructions and technical information for the components supplied by Hartzell Propeller Inc. can be found in the following publications available on the Hartzell Propeller Inc. web site at www.hartzellprop.com.
- (a) Hartzell Propeller Inc. Manual 180 (30-61-80)
- Propeller Ice Protection System Manual
 - (b) Hartzell Propeller Inc. Manual 181 (30-60-81)
- Propeller Ice Protection System Component Maintenance Manual
 - (c) Hartzell Propeller Inc. Manual 182 (61-12-82)
- Propeller Electrical De-ice Boot Removal and Installation Manual
 - (d) Hartzell Propeller Inc. Manual 183 (61-12-83)
- Propeller Anti-icing Boot Removal and Installation Manual
- (11) Propeller ice protection system components not supplied by Hartzell Propeller Inc. are controlled by the applicable TC or STC holder's Instructions for Continued Airworthiness (ICA).
- (12) Install the spinner dome as follows:
- NOTE:** The following instructions relate to Hartzell Propeller Inc. spinners only. In some cases, the airframe manufacturer produced the spinner assembly. In those cases, refer to the airframe manufacturer's manual for spinner installation instructions.

CAUTION 1: TO PREVENT DAMAGE TO THE BLADE AND BLADE PAINT, WRAP THE BLADE SHANKS IN SEVERAL LAYERS OF MASKING OR DUCT TAPE BEFORE INSTALLING THE SPINNER DOME. REMOVE THE TAPE AFTER THE SPINNER IS INSTALLED.

CAUTION 2: THE SPINNER DOME WILL WOBBLE IF NOT ALIGNED PROPERLY, AND MAY AFFECT THE BALANCE OF THE PROPELLER.

- (a) Carefully slide the spinner dome over the reassembled propeller.
- (b) Secure the spinner dome to the spinner bulkhead with the supplied screws and washers.

D-1300

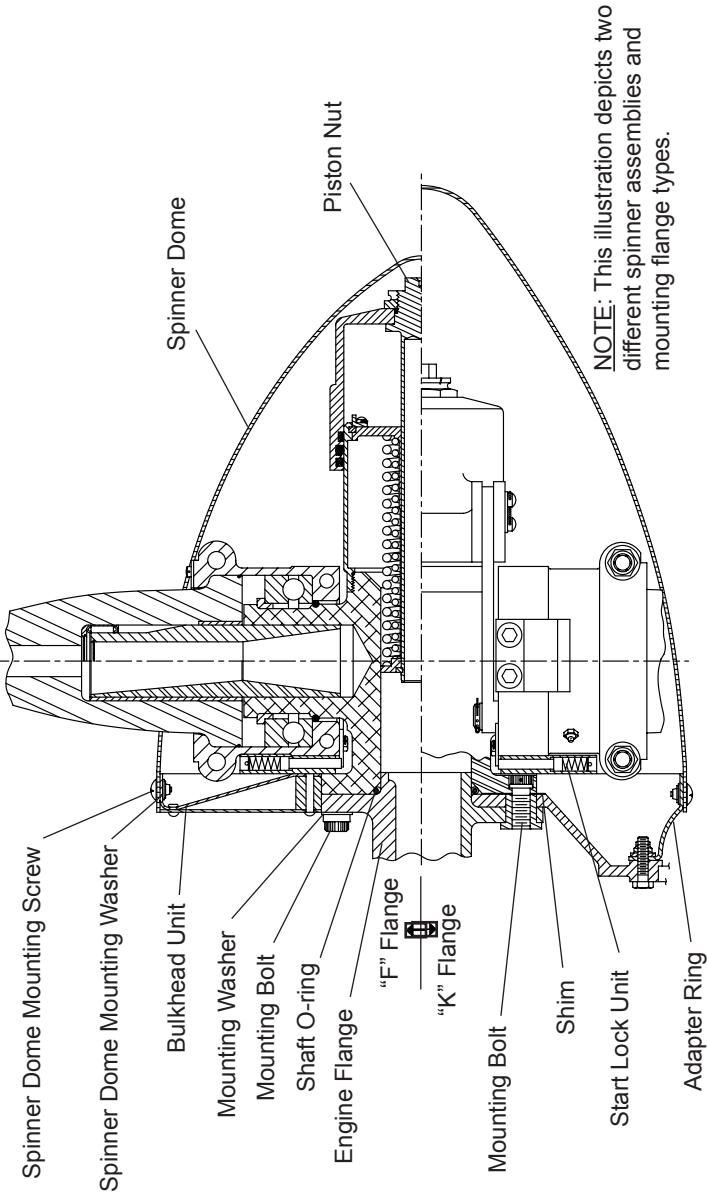

NOTE: This illustration depicts two different spinner assemblies and mounting flange types.

**HC-92ZF-2(), HC-92()K-2() Propeller Assembly
Figure 3-7**

D-1950

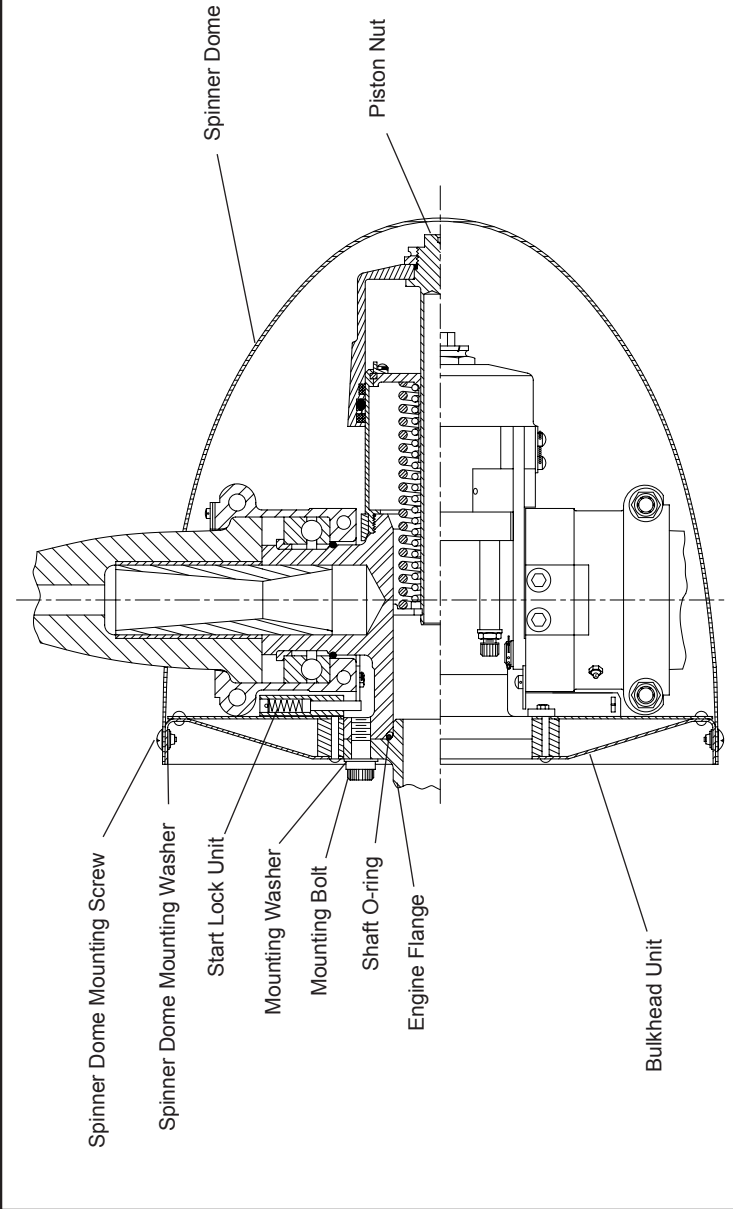

HC-93ZF-2() Propeller Assembly
Figure 3-8

- F. Installing the F Flange Propeller Models HC-92ZF-2() and HC-93ZF-2() Refer to Figures 3-7 and 3-8.
- (1) Press two dowel pins (Table 3-1) through the holes in the propeller flange to be flush with the propeller side of the hub flange.

WARNING 1: TO FACILITATE BOXING AND SHIPPING OF THE PROPELLER, THE PISTON NUT SHOULD HAVE BEEN REMOVED IN ORDER TO PERMIT ROTATING OF THE BLADES BEFORE PACKAGING.

FOR SAFETY REASONS, IF THE PISTON NUT WAS NOT REMOVED, THE PROPELLER MUST BE PUT IN FEATHER POSITION BEFORE IT IS INSTALLED ON THE AIRCRAFT.

WARNING 2: MAKE SURE THE SLING IS RATED UP TO 800 LBS. (363 KG) TO SUPPORT THE WEIGHT OF THE PROPELLER ASSEMBLY DURING INSTALLATION.

CAUTION 1: INSTRUCTIONS AND PROCEDURES IN THIS SECTION MAY INVOLVE PROPELLER CRITICAL PARTS. REFER TO THE INTRODUCTION CHAPTER OF THIS MANUAL FOR INFORMATION ABOUT PROPELLER CRITICAL PARTS.

CAUTION 2: WHEN INSTALLING THE PROPELLER ON THE AIRCRAFT, DO NOT DAMAGE THE ICE PROTECTION SYSTEM COMPONENTS, IF APPLICABLE.

- (2) With a suitable crane hoist and sling, carefully move the propeller assembly to the aircraft engine mounting flange in preparation for installation.

WARNING: ADHESIVES AND SOLVENTS ARE FLAMMABLE AND TOXIC TO THE SKIN, EYES, AND RESPIRATORY TRACT. SKIN AND EYE PROTECTION ARE REQUIRED. AVOID PROLONGED CONTACT AND BREATHING OF VAPORS. USE SOLVENT RESISTANT GLOVES TO MINIMIZE SKIN CONTACT AND WEAR SAFETY GLASSES FOR EYE PROTECTION. USE IN A WELL VENTILATED AREA AWAY FROM SPARKS AND FLAME. READ AND OBSERVE ALL WARNING LABELS.

- (3) Clean the engine flange and propeller flange with Quick Dry Stoddard Solvent or MEK.
- (4) If the spinner bulkhead is to be installed and is not already in place, perform the following steps:
 - (a) Install the spinner bulkhead facing toward the propeller.
 - (b) From the engine side of the bulkhead, insert the attaching bolts through the bulkhead and into the start locks.
 - (c) Install the washers and locking nuts on the propeller side of the start locks to secure the attaching bolts and the bulkhead.
- (5) Install the shaft O-ring on the engine shaft. Refer to Table 3-1.

CAUTION: USE CARE TO AVOID SCRAPING ALUMINUM FROM THE BORE OF THE SPINNER BULKHEAD. SCRAPINGS COULD BECOME WEDGED BETWEEN THE FLANGES.

- (6) Align the threaded holes of the propeller flange with the bolt holes in the engine flange, and align the dowel pins in the propeller flange with the dowel pin holes in the engine flange.

CAUTION: MAKE SURE THAT COMPLETE AND TRUE SURFACE CONTACT IS ESTABLISHED BETWEEN THE PROPELLER HUB FLANGE AND THE ENGINE FLANGE.

(7) Slide the propeller onto the engine shaft.

NOTE: Propeller model HC-93ZF-2B only: When sliding the propeller onto the engine shaft, the bottom of the spring assembly protrudes from the propeller assembly and fits into the engine flange.

CAUTION: NEW PROPELLER MOUNTING BOLTS MUST BE USED WHEN INITIALLY INSTALLING A NEW OR OVERHAULED PROPELLER.

(8) Install mounting bolts with mounting washers through the engine flange from the rear and into the tapped holes in the propeller flange. Refer to Table 3-1.

NOTE: For propeller removals between overhaul intervals, mounting bolts and washers may be reused if they are not damaged or corroded.

(9) Use a torque wrench with a torque wrench adapter Hartzell Propeller Inc. P/N AST-2814 to torque all mounting bolts in sequence in accordance with Table 3-2, Torque Values Table, Figure 3-2, and Figure 3-3 to determine the proper torque value to which the torque wrench must be set.

(a) Torque the mounting bolts to half of the final torque, beginning with any mounting bolt, and moving clockwise or counterclockwise until all the bolts are torqued.

(b) Final torque the bolts in sequence, beginning with any mounting bolt, and moving clockwise or counterclockwise until all the bolts are torqued.

(10) Safety all mounting bolts with 0.032 inch (0.810 mm) minimum diameter stainless steel wire or equivalent aircraft safety cable and associated hardware (two bolts per safety).

- (11) Procedure for reinstallation of the piston nut, if applicable.
- (a) Following the installation of the propeller, retract the start lock pins and hold them in place with a heavy wire inserted through the hole of each start lock housing.
 - (b) Carefully push the piston toward the engine, rotating the blades to feather position, and attach the piston nut to the pitch change rod.
 - (c) Use a breaker bar and a 5/8 inch deep well socket to hold the pitch change rod.
 - (d) Using a 1-7/16 inch crowfoot wrench and torque wrench, torque the piston nut in accordance with Table 3-2, Torque Values Table and Figure 3-3 for the proper torque value.

NOTE: The removal and subsequent reinstallation of the piston nut does not require that the propeller blade angles be rechecked.

(12) Remove the wires from the start lock brackets.

(13) Position the propeller on the start locks.

CAUTION: DO NOT PUT THE BLADE PADDLE IN THE AREA OF THE DE-ICE BOOT WHEN APPLYING TORQUE TO A BLADE ASSEMBLY. PUT THE BLADE PADDLE IN THE THICKEST AREA OF THE BLADE, JUST OUTSIDE OF THE DE-ICE BOOT. USE ONE BLADE PADDLE PER BLADE.

(a) Using the blade paddles, slowly rotate the blades simultaneously toward low pitch until the start lock pins engage the stop plate.

(14) If the propeller is equipped with an ice protection system that uses components supplied by Hartzell Propeller Inc., applicable instructions and technical information for the components supplied by Hartzell Propeller Inc. can be found in the following publications available on the Hartzell Propeller Inc. web site at www.hartzellprop.com.

(a) Hartzell Propeller Inc. Manual 180 (30-61-80)
- Propeller Ice Protection System Manual

- (b) Hartzell Propeller Inc. Manual 181 (30-60-81)
- Propeller Ice Protection System Component Maintenance Manual
 - (c) Hartzell Propeller Inc. Manual 182 (61-12-82)
- Propeller Electrical De-ice Boot Removal and Installation Manual
 - (d) Hartzell Propeller Inc. Manual 183 (61-12-83)
- Propeller Anti-icing Boot Removal and Installation Manual
- (15) Propeller ice protection system components not supplied by Hartzell Propeller Inc. are controlled by the applicable TC or STC holder's Instructions for Continued Airworthiness (ICA).

(16) Install the spinner dome as follows:

NOTE: The following instructions relate to Hartzell Propeller Inc. spinners only. In some cases, the airframe manufacturer produced the spinner assembly. In those cases, refer to the airframe manufacturer's manual for spinner installation instructions.

CAUTION 1: TO PREVENT DAMAGE TO THE BLADE AND BLADE PAINT, WRAP THE BLADE SHANKS IN SEVERAL LAYERS OF MASKING OR DUCT TAPE BEFORE INSTALLING THE SPINNER DOME. REMOVE THE TAPE AFTER THE SPINNER IS INSTALLED.

CAUTION 2: THE SPINNER DOME WILL WOBBLE IF NOT ALIGNED PROPERLY, AND MAY AFFECT THE BALANCE OF THE PROPELLER.

- (a) Carefully slide the spinner dome over the reassembled propeller.
- (b) Secure the spinner dome to the spinner bulkhead with the supplied screws and washers.

D-1300

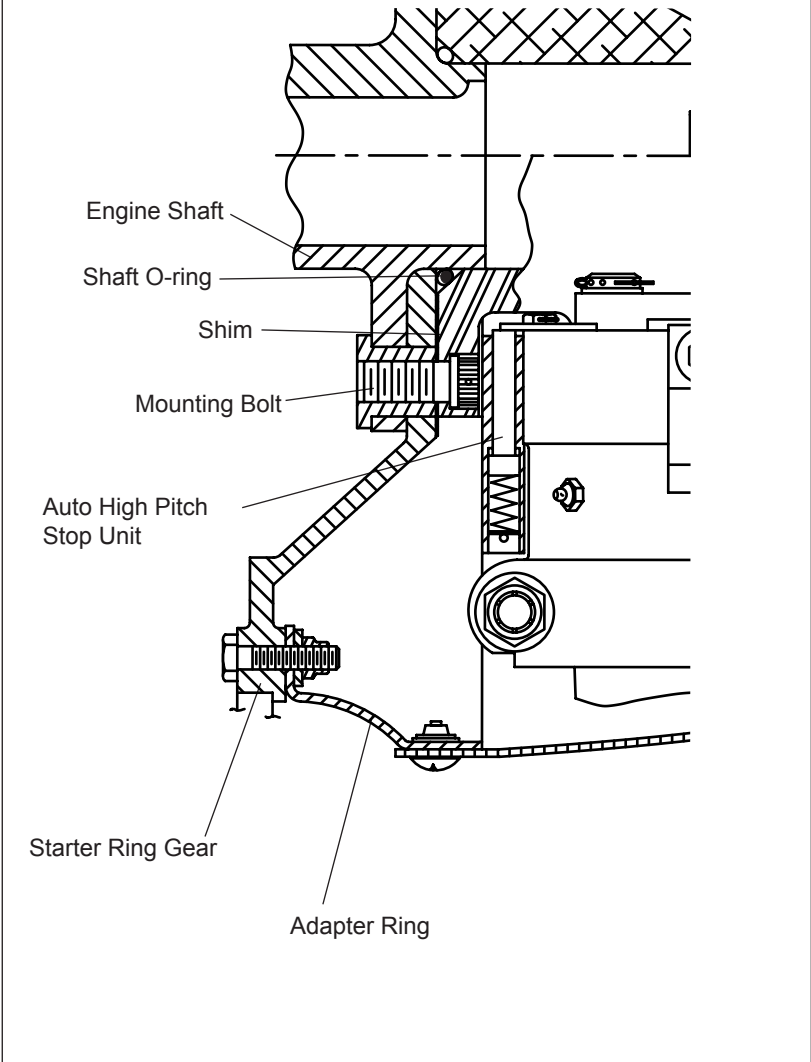

**K Flange Installation on -2 Propeller Models
Figure 3-9**

- G. Installing the K Flange Propeller Models HC-92()K-2()
Refer to Figure 3-7.

WARNING 1: TO FACILITATE BOXING AND SHIPPING OF THE PROPELLER, THE PISTON NUT SHOULD HAVE BEEN REMOVED IN ORDER TO PERMIT ROTATING OF THE BLADES BEFORE PACKAGING.

FOR SAFETY REASONS, IF THE PISTON NUT WAS NOT REMOVED, THE PROPELLER MUST BE PUT IN FEATHER POSITION BEFORE IT IS INSTALLED ON THE AIRCRAFT.

WARNING 2: MAKE SURE THE SLING IS RATED UP TO 800 LBS. (363 KG) TO SUPPORT THE WEIGHT OF THE PROPELLER ASSEMBLY DURING INSTALLATION.

CAUTION 1: INSTRUCTIONS AND PROCEDURES IN THIS SECTION MAY INVOLVE PROPELLER CRITICAL PARTS. REFER TO THE INTRODUCTION CHAPTER OF THIS MANUAL FOR INFORMATION ABOUT PROPELLER CRITICAL PARTS.

CAUTION 2: WHEN INSTALLING THE PROPELLER ON THE AIRCRAFT, DO NOT DAMAGE THE ICE PROTECTION SYSTEM COMPONENTS, IF APPLICABLE.

- (1) With a suitable crane hoist and sling, carefully move the propeller assembly to the aircraft engine mounting flange in preparation for installation.

WARNING: ADHESIVES AND SOLVENTS ARE FLAMMABLE AND TOXIC TO THE SKIN, EYES, AND RESPIRATORY TRACT. SKIN AND EYE PROTECTION ARE REQUIRED. AVOID PROLONGED CONTACT AND BREATHING OF VAPORS. USE SOLVENT RESISTANT GLOVES TO MINIMIZE SKIN CONTACT AND WEAR SAFETY GLASSES FOR EYE PROTECTION. USE IN A WELL VENTILATED AREA AWAY FROM SPARKS AND FLAME. READ AND OBSERVE ALL WARNING LABELS.

- (2) Clean the engine flange and propeller flange with Quick Dry Stoddard Solvent or MEK.
- (3) Install the spinner adapter ring on the engine starter gear. Refer to Figure 3-9.

CAUTION: FAILURE TO INSTALL THE PLASTIC SHIM BETWEEN THE PROPELLER FLANGE AND THE STARTER RING GEAR CAN RESULT IN MOUNTING BOLT FAILURE.

- (4) Install the plastic shim on the engine shaft between the starter ring gear and the propeller flange. Refer to Figure 3-9.
- (5) Install the specified shaft O-ring on the engine shaft. Refer to Table 3-1.

WARNING: THE PROPELLER MUST BE IN FEATHER POSITION BEFORE REMOVING THE START LOCKS.

- (6) Remove the start locks to gain access to the propeller mounting bolts.
- (7) Align the six mounting bolts in the propeller hub flange with the bushings in the engine flange.

NOTE 1: The propeller mounting bolts are already installed in the propeller flange. Interference with other propeller parts requires that the bolts be installed during propeller assembly.

NOTE 2: For propeller removals between overhaul intervals, mounting bolts and washers may be reused if they are not damaged or corroded.

CAUTION: MAKE SURE THAT COMPLETE AND TRUE SURFACE CONTACT IS ESTABLISHED BETWEEN THE PROPELLER HUB FLANGE AND THE STARTER RING GEAR.

(8) Slide the propeller flange onto the engine flange against the starter ring gear.

NOTE: The engine bushings will insert into the counterbores in the propeller flange that encircles the propeller mounting bolts.

CAUTION: NEW PROPELLER MOUNTING BOLTS MUST BE USED WHEN INITIALLY INSTALLING A NEW OR OVERHAULED PROPELLER.

(9) Use a torque wrench with a torque wrench adapter Hartzell Propeller Inc. P/N AST-2805 to torque all mounting bolts in sequence in accordance with Table 3-2, Torque Values Table, Figure 3-6, and Figure 3-3 to determine the proper torque value to which the torque wrench must be set.

(a) Torque the mounting bolts to half of the final torque, beginning with any mounting bolt, and moving clockwise or counterclockwise until all the bolts are torqued.

(b) Perform the final torque of the bolts in sequence, beginning with any mounting bolt, and moving clockwise or counterclockwise until all the bolts are torqued.

(10) Install the start locks.

(11) Safety all mounting bolts with 0.032 inch (0.810 mm) minimum diameter stainless steel wire or equivalent aircraft safety cable and associated hardware (two bolts per safety).

NOTE: The mounting bolts that are adjacent to the start locks must be safety-wired to the start lock brackets.

- (12) Procedure for reinstallation of the piston nut, if applicable.
- (a) Following the installation of the propeller, retract the start lock pins and hold them in place with a heavy wire inserted through the hole of each start lock housing.
 - (b) Carefully push the piston toward the engine, rotating the blades to feather position, and attach the piston nut to the pitch change rod.
 - (c) Use a breaker bar and a 5/8 inch deep well socket to hold the pitch change rod.
 - (d) Using a 1-7/16 inch crowfoot wrench and torque wrench, torque the piston nut in accordance with Table 3-2, Torque Values Table, and Figure 3-3 for the proper torque value.

NOTE: The removal and subsequent reinstallation of the piston nut does not require that the propeller blade angles be rechecked.

(13) Remove the wires from the start lock brackets.

(14) Position the propeller on the start locks.

CAUTION: DO NOT PUT THE BLADE PADDLE IN THE AREA OF THE DE-ICE BOOT WHEN APPLYING TORQUE TO A BLADE ASSEMBLY. PUT THE BLADE PADDLE IN THE THICKEST AREA OF THE BLADE, JUST OUTSIDE OF THE DE-ICE BOOT. USE ONE BLADE PADDLE PER BLADE.

- (a) Using the blade paddles, slowly rotate the blades simultaneously toward low pitch until the start lock pins engage the stop plate.
- (15) If the propeller is equipped with an ice protection system that uses components supplied by Hartzell Propeller Inc., applicable instructions and technical information for the components supplied by Hartzell Propeller Inc. can be found in the following publications available on the Hartzell Propeller Inc. web site at www.hartzellprop.com.
- (a) Hartzell Propeller Inc. Manual 180 (30-61-80)
- Propeller Ice Protection System Manual

- (b) Hartzell Propeller Inc. Manual 181 (30-60-81)
- Propeller Ice Protection System Component Maintenance Manual
- (c) Hartzell Propeller Inc. Manual 182 (61-12-82)
- Propeller Electrical De-ice Boot Removal and Installation Manual
- (d) Hartzell Propeller Inc. Manual 183 (61-12-83)
- Propeller Anti-icing Boot Removal and Installation Manual

(16) Propeller ice protection system components not supplied by Hartzell Propeller Inc. are controlled by the applicable TC or STC holder's Instructions for Continued Airworthiness (ICA).

(17) Install the spinner dome as follows:

NOTE: The following instructions relate to Hartzell Propeller Inc. spinners only. In some cases, the airframe manufacturer produced the spinner assembly. In those cases, refer to the airframe manufacturer's manual for spinner installation instructions.

CAUTION 1: TO PREVENT DAMAGE TO THE BLADE AND BLADE PAINT, WRAP THE BLADE SHANKS IN SEVERAL LAYERS OF MASKING OR DUCT TAPE BEFORE INSTALLING THE SPINNER DOME. REMOVE THE TAPE AFTER THE SPINNER IS INSTALLED.

CAUTION 2: THE SPINNER DOME WILL WOBBLE IF NOT ALIGNED PROPERLY, AND MAY AFFECT THE BALANCE OF THE PROPELLER.

- (a) Carefully slide the spinner dome over the reassembled propeller.
- (b) Secure the spinner dome to the spinner bulkhead with the supplied screws and washers.

H. Installing the F Flange Propeller Models (B)HC-92()F-3
Refer to Refer to Table 3-1 and Figure 3-10.

- (1) Use a beta system puller CST-2987 to compress the beta system and pull the beta ring forward to permit installation of the propeller mounting bolts. Refer to Figure 3-11.

WARNING: MAKE SURE THE SLING IS RATED UP TO 800 POUNDS (363 KG) TO SUPPORT THE WEIGHT OF THE PROPELLER ASSEMBLY DURING INSTALLATION.

CAUTION 1: INSTRUCTIONS AND PROCEDURES IN THIS SECTION MAY INVOLVE PROPELLER CRITICAL PARTS. REFER TO THE INTRODUCTION CHAPTER OF THIS MANUAL FOR INFORMATION ABOUT PROPELLER CRITICAL PARTS.

CAUTION 2: WHEN INSTALLING THE PROPELLER ON THE AIRCRAFT, DO NOT DAMAGE THE ICE PROTECTION SYSTEM COMPONENTS, IF APPLICABLE.

- (2) With a suitable crane hoist and sling, carefully move the propeller assembly to the aircraft engine mounting flange in preparation for installation.

WARNING: ADHESIVES AND SOLVENTS ARE FLAMMABLE AND TOXIC TO THE SKIN, EYES, AND RESPIRATORY TRACT. SKIN AND EYE PROTECTION ARE REQUIRED. AVOID PROLONGED CONTACT AND BREATHING OF VAPORS. USE SOLVENT RESISTANT GLOVES TO MINIMIZE SKIN CONTACT AND WEAR SAFETY GLASSES FOR EYE PROTECTION. USE IN A WELL VENTILATED AREA AWAY FROM SPARKS AND FLAME. READ AND OBSERVE ALL WARNING LABELS.

- (3) Clean the engine flange and propeller flange with Quick Dry Stoddard Solvent or MEK.

D-2975

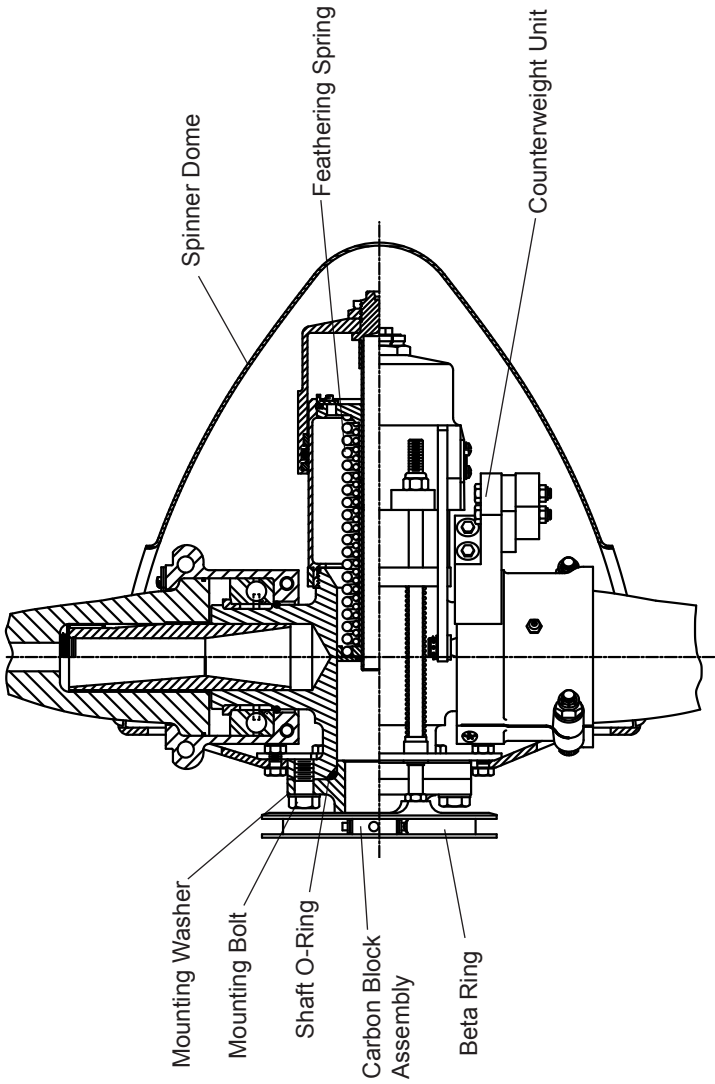

(B)HC-92 () F-3 Propeller Assembly
Figure 3-10

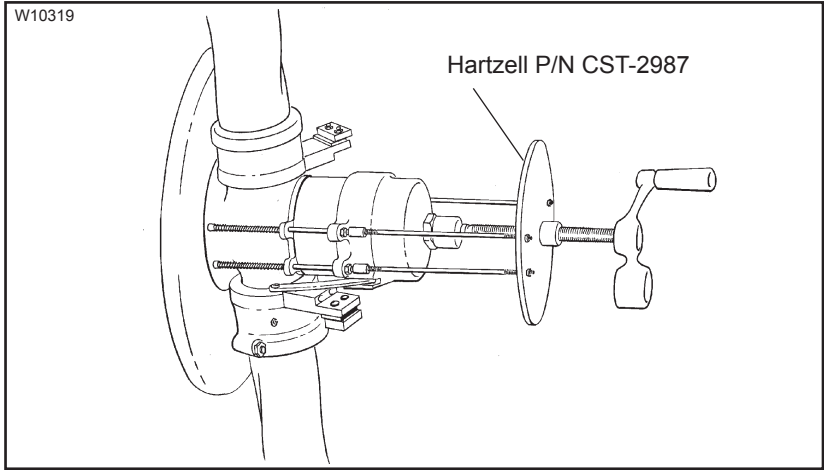

**Tool for Decompressing External Beta System
Figure 3-11**

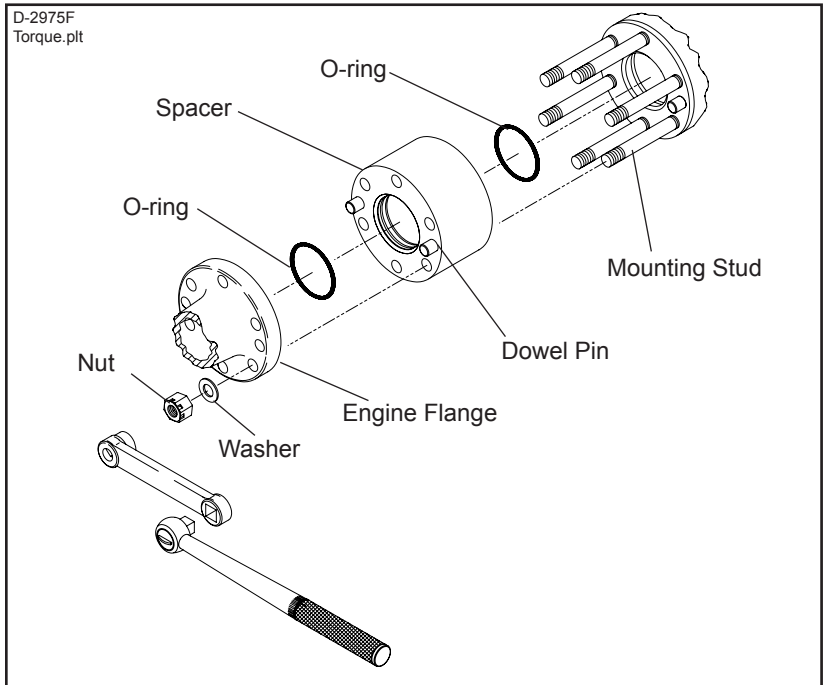

**HC-92WF-3 Installation on TSIO-520-C Engine
Figure 3-12**



- (4) Press fit two dowel pins through the holes in the propeller flange to be flush with the propeller side of the hub flange.
- (5) Install the specified O-ring on the engine flange.
NOTE: For propeller model HC-92WF-3 when installed on a TSIO-520-C engine only, proceed to step (6). For all other installations, proceed to step (7).
- (6) For propeller model HC-92WF-3 when installed on a TSIO-520-C engine only. Refer to Table 3-1.
 - (a) Install the specified O-ring on the spacer, facing the propeller flange.
 - (b) Install the spacer and O-ring against the propeller flange, matching the dowel pins in the propeller flange to the holes in the spacer.
 - (c) Press fit two dowel pins through the holes in the spacer, approximately 1/2 inch (12.7 mm) deep.
- (7) Align the mounting and dowel pin holes in the engine flange with the mounting holes (or studs) and dowel pins in the propeller flange or spacer as applicable.
- (8) Slide the propeller flange (or spacer) onto the engine flange.

D-2985F

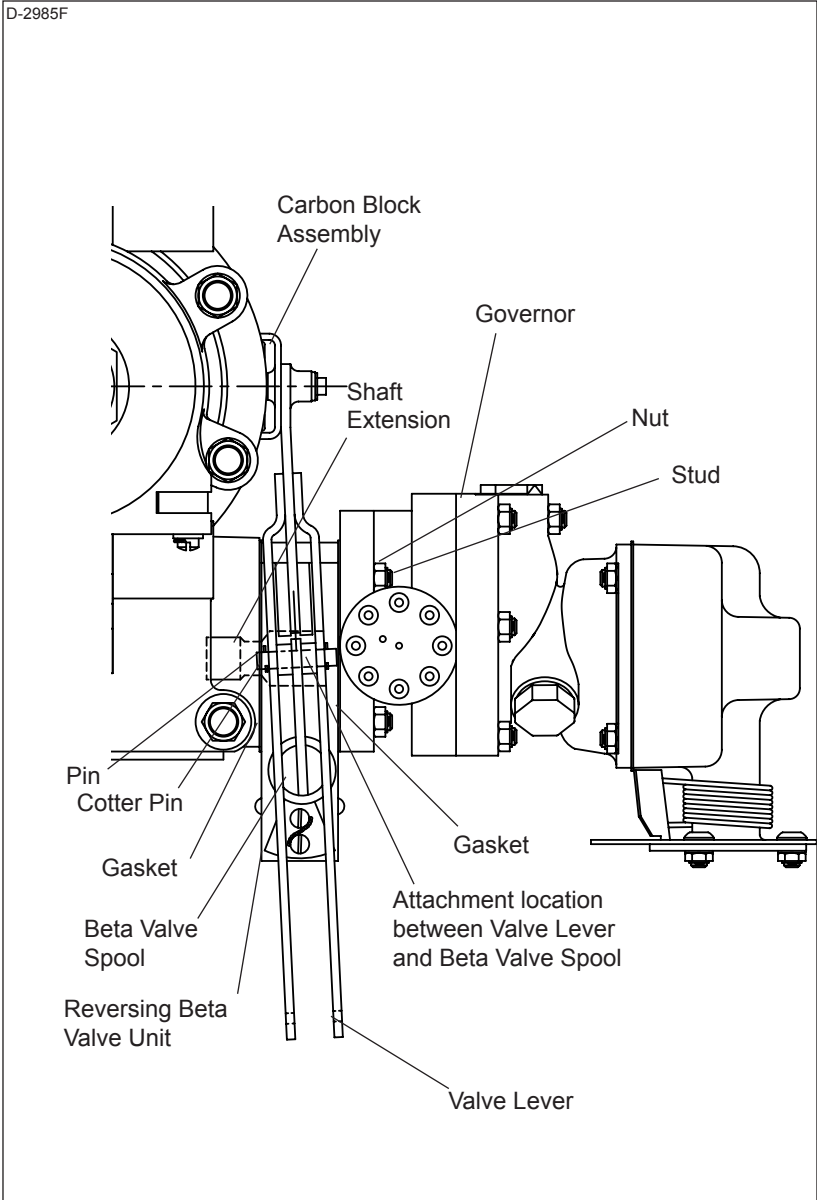

**Installation of Beta Valve, Governor, and Linkage
Figure 3-13**



APS0168B

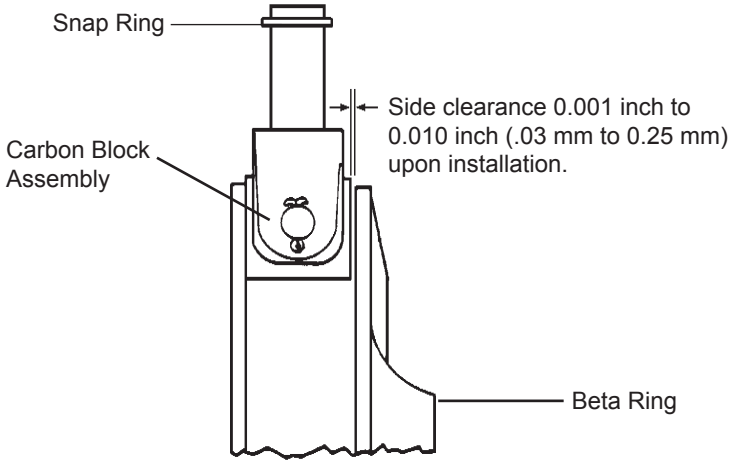

Carbon Block and Beta Ring Clearance
Figure 3-14

BPS0041

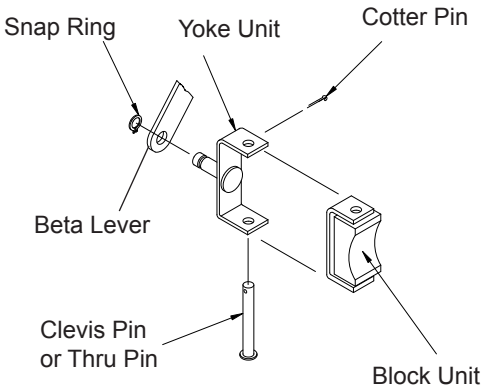

Carbon Block Assembly
Figure 3-15

CAUTION 1: MAKE SURE THAT COMPLETE AND TRUE SURFACE CONTACT IS ESTABLISHED BETWEEN THE PROPELLER HUB FLANGE (OR SPACER) AND THE ENGINE FLANGE.

CAUTION 2: NEW PROPELLER MOUNTING BOLTS OR STUDS MUST BE USED WHEN INITIALLY INSTALLING A NEW OR OVERHAULED PROPELLER.

(9) Install mounting bolts with washers, if applicable, through the engine flange and into the propeller hub flange. Refer to Figure 3-10.

NOTE 1: On propeller model HC-92WF-3 when installed on a TSIO-520-C engine, install mounting nuts with washers onto the mounting studs that protrude through the engine side of the engine flange. Refer to Figure 3-12.

NOTE 2: For propeller removals between overhaul intervals, mounting bolts and washers or studs and washers may be reused if they are not damaged or corroded.

(10) Use a torque wrench with a torque wrench adapter Hartzell Propeller Inc. P/N AST-2814 to torque all mounting bolts or nuts in sequence in accordance with Table 3-2, Torque Values Table, Figure 3-2, Figure 3-3, and Figure 3-12 to determine the proper torque value to which the torque wrench must be set.

(a) Torque the mounting bolts or nuts to half the final torque, beginning with any mounting bolt, and moving clockwise or counterclockwise until all the bolts are torqued.

(b) Final torque the bolts or nuts in sequence, beginning with any mounting bolt, and moving clockwise or counterclockwise until all the bolts are torqued.

(11) Safety all mounting bolts or mounting studs with 0.032 inch (0.81 mm) minimum diameter stainless steel wire or equivalent aircraft safety cable and associated hardware (two bolts or studs per safety).

(12) Decompress and remove the beta system puller.

(13) Install, adjust, and safety the beta linkage per the airframe manufacturer's instructions.

(14) If the propeller is equipped with an ice protection system that uses components supplied by Hartzell Propeller Inc., applicable instructions and technical information for the components supplied by Hartzell Propeller Inc. can be found in the following publications available on the Hartzell Propeller Inc. web site at www.hartzellprop.com.

- (a) Hartzell Propeller Inc. Manual 180 (30-61-80)
- Propeller Ice Protection System Manual
- (b) Hartzell Propeller Inc. Manual 181 (30-60-81)
- Propeller Ice Protection System Component Maintenance Manual
- (c) Hartzell Propeller Inc. Manual 182 (61-12-82)
- Propeller Electrical De-ice Boot Removal and Installation Manual
- (d) Hartzell Propeller Inc. Manual 183 (61-12-83)
- Propeller Anti-icing Boot Removal and Installation Manual

(15) Propeller ice protection system components not supplied by Hartzell Propeller Inc. are controlled by the applicable TC or STC holder's Instructions for Continued Airworthiness (ICA).

(16) Install the spinner dome as follows:

NOTE: The following instructions relate to Hartzell Propeller Inc. spinners only. In some cases, the airframe manufacturer produced the spinner assembly. In those cases, refer to the airframe manufacturer's manual for spinner installation instructions.

CAUTION 1: TO PREVENT DAMAGE TO THE BLADE AND BLADE PAINT, WRAP THE BLADE SHANKS IN SEVERAL LAYERS OF MASKING OR DUCT TAPE BEFORE INSTALLING THE SPINNER DOME. REMOVE THE TAPE AFTER THE SPINNER IS INSTALLED.

CAUTION 2: THE SPINNER DOME WILL WOBBLE IF NOT ALIGNED PROPERLY, AND MAY AFFECT BALANCE OF THE PROPELLER.

- (a) Carefully slide the spinner dome over the reassembled propeller.

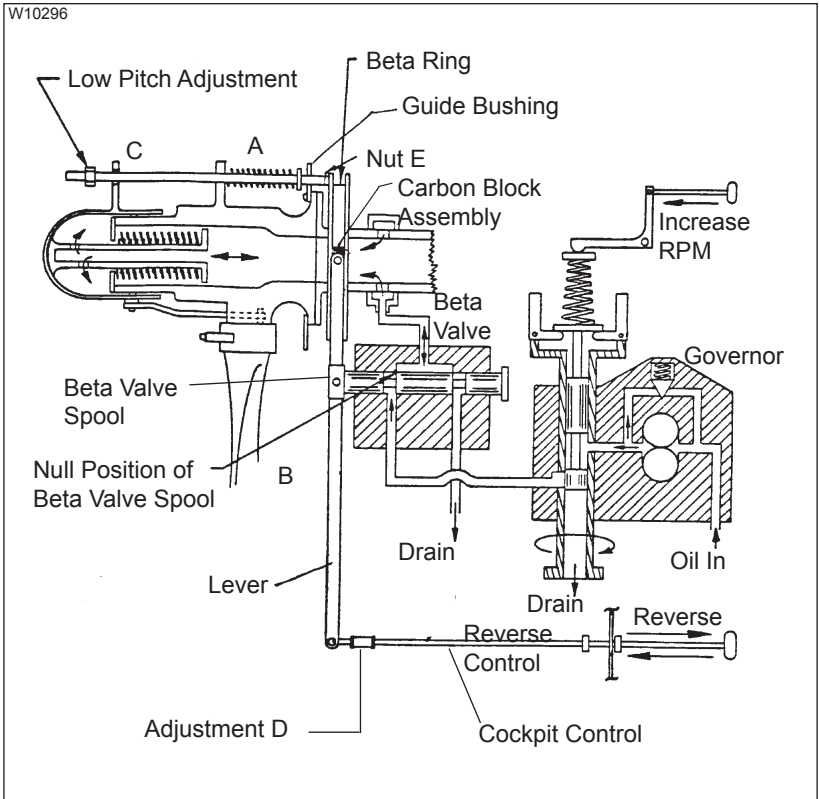

Adjusting Propeller Reverse Control System
Figure 3-16

- (b) Secure the spinner dome to the spinner bulkhead with the supplied screws and washers.
- (17) Installation of the beta valve, governor, and linkage. Refer to Figure 3-13 and Table 3-1.
 - (a) Remove the four studs from the engine governor pad and install four new longer studs.
 - (b) Install the governor gasket against the face of the engine pad.
 - (c) Install the beta valve unit as shown in Figure 3-13.
 - (d) Install a governor gasket against the valve face (contacting the governor).
 - (e) Install the shaft extension into the female splines of the engine governor drive shaft.
 - (f) Install the governor and attach it with nuts.

NOTE: Follow the applicable airframe manufacturer's instructions for the rigging of the governor control cable.
 - (g) Torque the nuts to 18-20 Ft-Lb (25-27 N•m).
 - (h) Install the carbon block into the beta linkage lever, per the airframe manufacturer's instructions.

CAUTION 1: FIT THE BLOCK IN THE BETA RING WITH A MINIMUM SIDE CLEARANCE OF 0.001 INCH (0.03 mm). REFER TO FIGURE 3-14.

CAUTION 2: MAXIMUM SIDE CLEARANCE PERMITTED IS 0.010 INCH (0.25 mm) IN ACCORDANCE WITH THE CARBON BLOCK ASSEMBLIES SECTION IN THE MAINTENANCE PRACTICES CHAPTER OF THIS MANUAL.

- (i) Install the carbon block assembly into the beta ring. Refer to Figure 3-15.
- (j) Attach the valve lever to the beta valve spool. Refer to Figure 3-13.

- (k) Install, adjust, and safety the beta linkage per the airframe manufacturer's instructions.

NOTE: If airframe manufacturer's instructions are unavailable, then follow step 4.H.(18).

- (l) Connect the outer end of the lever with the control push-pull fitting provided.
- (m) Secure the housing of the push-pull control to a bracket.

(18) Adjusting the Propeller Reverse Control System

NOTE: Follow the instructions in this step only if the manufacturer's instructions for this procedure are unavailable.

Refer to Figure 3-16.

- (a) Set the reverse control in forward position.
- (b) Adjust "D", at the end of the reverse control rod, so that "B" is approximately 1/16 inch (1.6 mm) as measured from the spool flange to the valve body (or within 1/16 inch (1.6 mm) of the end of its travel).

NOTE: "A" is zero.

- (c) The low pitch adjustment "C" has been made at the factory according to published information. The readjustment of low pitch should not be required. Refer to the Propeller Low Pitch Setting section in the Maintenance Practices Chapter of this manual for adjustment information.

CAUTION: TO PREVENT ENGINE OVERSPEED, DO NOT PERMIT THE RPM TO REACH THE RPM SET BY THE GOVERNOR. THIS WILL PERMIT THE GOVERNOR TO OVERRIDE THE REVERSE PITCH CONTROL AND CAUSE THE PITCH TO COME OUT OF REVERSE.

- (d) Check the RPM during reverse pitch operation.
 - 1 Set the propeller governor control for maximum RPM.
 - 2 While the engine is idling, set the pitch control for maximum reverse pitch.

- 3 Gradually open the throttle until the RPM reaches the maximum value, or until the RPM reaches approximately 80 percent to 90 percent of the engine rating.

NOTE: It is desirable to have the reverse pitch set to provide 80 percent to 90 percent of the engine rated RPM. This provides a margin of safety for reverse pitch operation.

CAUTION: DO NOT PUT THE BLADE PADDLE IN THE AREA OF THE DE-ICE BOOT WHEN APPLYING TORQUE TO A BLADE ASSEMBLY. PUT THE BLADE PADDLE IN THE THICKEST AREA OF THE BLADE, JUST OUTSIDE OF THE DE-ICE BOOT. USE ONE BLADE PADDLE PER BLADE.

- (e) If the RPM exceeds the desired value for reverse pitch, check to be sure the reverse push-pull control has enough travel to move the piston up against its internal stop. Refer to Figure 3-16. To accomplish this:
 - 1 Using blade paddles (one per blade), rotate the blade angle into full reverse pitch, and determine if the beta valve is calling for oil pressure. This condition is met if "B" is 3/16 inch (4.8 mm) or less.
 - 2 While in full reverse, check for clearance between nut "E" and the guide bushing. There should be a positive clearance.

- I. Installing the F Flange Propeller Models BHC-92(W,Z)F-3(L)G
Refer to Figure 3-17.

- (1) Use a beta system puller CST-2987 to compress the beta system and pull the beta ring forward to permit installation of the mounting nuts. Refer to Figure 3-11.

WARNING: MAKE SURE THE SLING IS RATED UP TO 800 POUNDS (363 KG) TO SUPPORT THE WEIGHT OF THE PROPELLER ASSEMBLY DURING INSTALLATION.

CAUTION 1: INSTRUCTIONS AND PROCEDURES IN THIS SECTION MAY INVOLVE PROPELLER CRITICAL PARTS. REFER TO THE INTRODUCTION CHAPTER OF THIS MANUAL FOR INFORMATION ABOUT PROPELLER CRITICAL PARTS.

CAUTION 2: WHEN INSTALLING THE PROPELLER ON THE AIRCRAFT, DO NOT DAMAGE THE ICE PROTECTION SYSTEM COMPONENTS, IF APPLICABLE.

- (2) With a suitable crane hoist and sling, carefully move the propeller assembly to the aircraft engine mounting flange in preparation for installation.

WARNING: ADHESIVES AND SOLVENTS ARE FLAMMABLE AND TOXIC TO THE SKIN, EYES, AND RESPIRATORY TRACT. SKIN AND EYE PROTECTION ARE REQUIRED. AVOID PROLONGED CONTACT AND BREATHING OF VAPORS. USE SOLVENT RESISTANT GLOVES TO MINIMIZE SKIN CONTACT AND WEAR SAFETY GLASSES FOR EYE PROTECTION. USE IN A WELL VENTILATED AREA AWAY FROM SPARKS AND FLAME. READ AND OBSERVE ALL WARNING LABELS.

- (3) Clean the engine flange and propeller flange with Quick Dry Stoddard Solvent or MEK.
- (4) Press fit two dowel pins through the holes in the propeller flange to be flush with the propeller side of the hub flange. Refer to Table 3-1 and Figure 3-18.
- (5) Install the specified O-ring on the engine flange. Refer to Table 3-1.
- (6) Install the specified O-ring on the adapter pulley, facing the propeller flange. Refer to Table 3-1 and and Figure 3-18.
- (7) Install the spacer and O-ring against the propeller flange, matching the dowel pins in the propeller flange to the holes in the spacer. Refer to Figure 3-18.
- (8) Press fit two dowel pins through the holes in the adapter pulley, to a depth of approximately 0.50 inch (12.7 mm). Refer to Table 3-1 and Figure 3-18.
- (9) Align the mounting and dowel pin holes in the engine flange with the mounting studs and dowel pins in the adapter pulley.
- (10) Slide the propeller and adapter pulley onto the engine flange.

D-2985

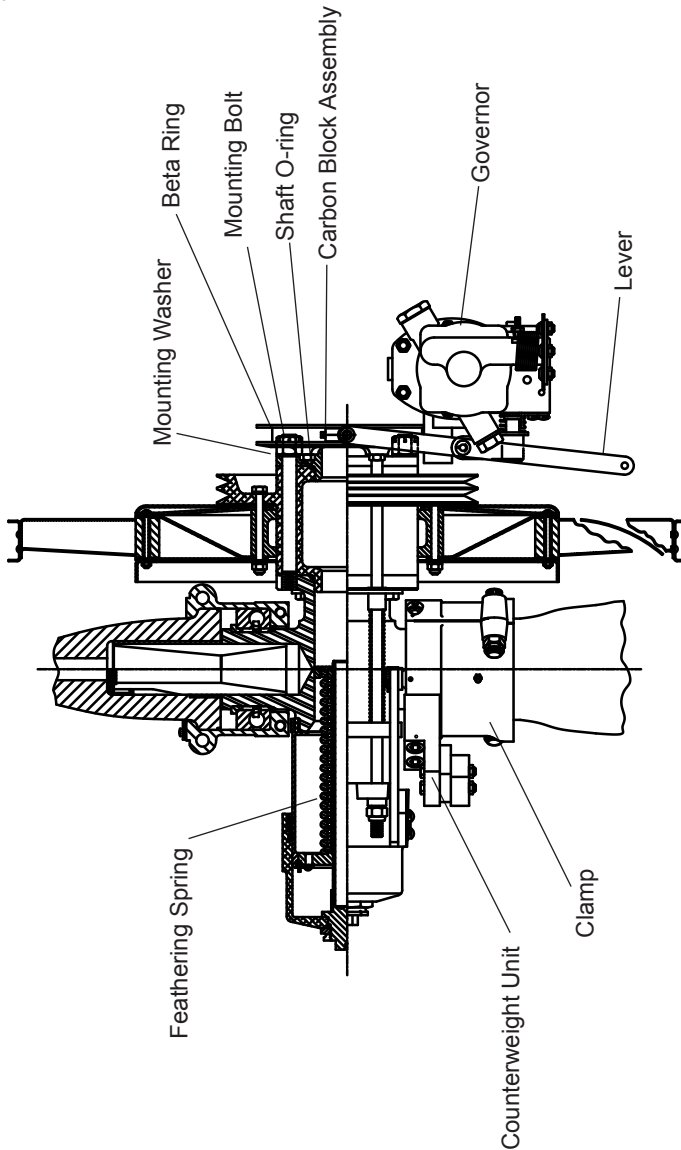

BHC-92(W,Z)F-3(L)G Propeller Assembly
Figure 3-17

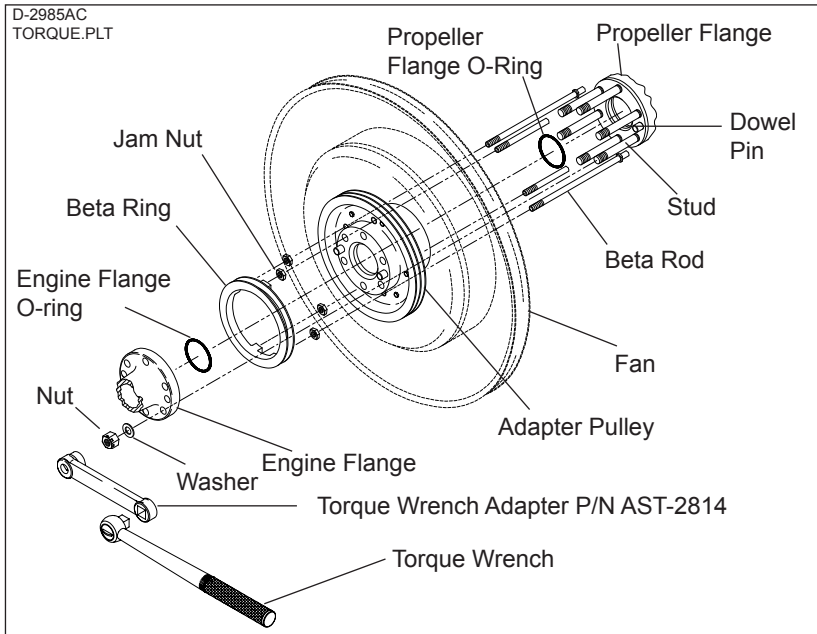

**BHC-92(W,Z)F-3(L)G Installation
Figure 3-18**



CAUTION 1: MAKE SURE THAT COMPLETE AND TRUE SURFACE CONTACT IS ESTABLISHED BETWEEN THE PROPELLER HUB FLANGE AND ADAPTER PULLEY, AND THE ENGINE FLANGE.

CAUTION 2: NEW PROPELLER MOUNTING BOLTS OR STUDS MUST BE USED WHEN INITIALLY INSTALLING A NEW OR OVERHAULED PROPELLER.

(11) Install mounting nuts with washers through the engine flange and into the propeller hub flange. Refer to Table 3-1 and Figure 3-18.

NOTE: For propeller removals between overhaul intervals, mounting studs and washers may be reused if they are not damaged or corroded.

(12) Use a torque wrench with a torque wrench adapter Hartzell Propeller Inc. P/N AST-2814 to torque all mounting nuts in sequence in accordance with Table 3-2, Torque Values Table, Figure 3-2, and Figure 3-3 to determine the proper torque value to which the torque wrench must be set.

(a) Torque the mounting nuts to half of the final torque, beginning with any mounting nut, and moving clockwise or counterclockwise until all the bolts are torqued.

(b) Final torque the nuts in sequence, beginning with any nut, and moving clockwise or counterclockwise until all the bolts are torqued.

(13) Safety all mounting studs with 0.032 inch (0.81 mm) minimum diameter stainless steel wire or equivalent aircraft safety cable and associated hardware (two studs per safety).

(14) Decompress and remove the beta system puller.

(15) Install, adjust, and safety the beta linkage per the airframe manufacturer's instructions.

(16) Installation of the beta valve, governor, and linkage. Refer to Figure 3-13 and Table 3-1.

(a) Remove the four studs from the engine governor pad and install four new longer studs.

- (b) Install the governor gasket against the face of the engine pad.
- (c) Install the beta valve unit as shown in Figure 3-13.
- (d) Install a governor gasket against the valve face (contacting the governor).
- (e) Install the shaft extension into the female splines of the engine governor drive shaft.
- (f) Install the governor and attach it with nuts.
NOTE: Follow the applicable airframe manufacturer's instructions for the rigging of the governor control cable.
- (g) Torque the nuts to 18-20 Ft-Lb (25-27 N•m).
- (h) Install the carbon block into the beta linkage lever, per the airframe manufacturer's instructions.

CAUTION 1: FIT THE BLOCK IN THE BETA RING WITH A MINIMUM SIDE CLEARANCE OF 0.001 INCH (0.03 mm). REFER TO FIGURE 3-14.

CAUTION 2: MAXIMUM SIDE CLEARANCE PERMITTED IS 0.010 INCH (0.25 mm) IN ACCORDANCE WITH THE CARBON BLOCK ASSEMBLIES SECTION IN THE MAINTENANCE PRACTICES CHAPTER OF THIS MANUAL.

- (i) Install the carbon block assembly into the beta ring. Refer to Figure 3-15.
- (j) Attach the valve lever to the beta valve spool. Refer to Figure 3-13.
- (k) Install, adjust, and safety the beta linkage per the airframe manufacturer's instructions.
NOTE: If airframe manufacturer's instructions are unavailable, then follow step 4.I.(17).
- (l) Connect the outer end of the lever with the control push-pull fitting provided.
- (m) Attach the housing of the push-pull control to a bracket.

(17) Adjusting the Propeller Reverse Control System

NOTE: Follow the instructions in this step only if the manufacturer's instructions for this procedure are unavailable.

Refer to Figure 3-16.

- (a) Set the reverse control in forward position.
- (b) Adjust "D", at the end of the reverse control rod, so that "B" is approximately 1/16 inch (1.6 mm) as measured from the spool flange to the valve body (or within 1/16 inch (1.6 mm) of the end of its travel).

NOTE: "A" is zero.

- (c) The low pitch adjustment "C" has been made at the factory according to published information. The readjustment of low pitch should not be required. Refer to the Propeller Low Pitch Setting section in the Maintenance Practices Chapter of this manual for adjustment information.
- (d) Check the runout of the beta ring by installing a dial indicator on the nose of the engine, so that it touches the rear face of the beta ring. If necessary, loosen nut "E" and rotate the rods to bring the runout to within 0.010 total indicator reading.
- (e) Torque nut "E" to 10-15 Ft-Lb (14-20 N•m).
- (f) Make sure the four low pitch adjusting nuts contact the piston bosses at the same time the piston is moved toward reverse pitch. To accomplish this:
 - 1 Equalize "C" for all four rods by means of accurate measurements. Refer to Figure 3-16.
 - 2 Adjust the nuts if necessary. This will make sure that the slip ring runs true during pitch reversal.

CAUTION: TO PREVENT ENGINE OVERSPEED, DO NOT PERMIT THE RPM TO REACH THE RPM SET BY THE GOVERNOR. THIS WILL PERMIT THE GOVERNOR TO OVERRIDE THE REVERSE PITCH CONTROL AND CAUSE THE PITCH TO COME OUT OF REVERSE.

- (g) Check the RPM during reverse pitch operation.
- 1 Set the propeller governor control for maximum RPM.
 - 2 While the engine is idling, set the pitch control for maximum reverse pitch.
 - 3 Gradually open the throttle until the RPM reaches the maximum value, or until the RPM reaches approximately 80 percent to 90 percent of the engine rating.

NOTE: It is desirable to have the reverse pitch set to provide 80 percent to 90 percent of the engine rated RPM. This provides a margin of safety for reverse pitch operation.

CAUTION: DO NOT PUT THE BLADE PADDLE IN THE AREA OF THE DE-ICE BOOT WHEN APPLYING TORQUE TO A BLADE ASSEMBLY. PUT THE BLADE PADDLE IN THE THICKEST AREA OF THE BLADE, JUST OUTSIDE OF THE DE-ICE BOOT. USE ONE BLADE PADDLE PER BLADE.

- (h) If the RPM exceeds the desired value for reverse pitch, check to be sure the reverse push-pull control has enough travel to move the piston up against its internal stop. Refer to Figure 3-16. To accomplish this:
- 1 Using blade paddles (one per blade), rotate the blade angle into full reverse pitch, and determine if the beta valve is calling for oil pressure. This condition is met if "B" (Figure 3-16) is 3/16 inch (4.8 mm) or less.

- 2 While in full reverse, check for clearance between nut "E" and the guide bushing. There should be a positive clearance. Refer to Figure 3-16.

- J. Installing the F Flange Propeller Model HC-92WF-5A
Refer to Figure 3-19.

- (1) Use a beta system puller CST-2987 to compress the beta system and pull the beta ring forward to permit installation of the double hex head propeller mounting fasteners. Refer to Figure 3-11.

WARNING: MAKE SURE THE SLING IS RATED UP TO 800 LBS. (363 KG) TO SUPPORT THE WEIGHT OF THE PROPELLER ASSEMBLY DURING INSTALLATION.

CAUTION 1: INSTRUCTIONS AND PROCEDURES IN THIS SECTION MAY INVOLVE PROPELLER CRITICAL PARTS. REFER TO THE INTRODUCTION CHAPTER OF THIS MANUAL FOR INFORMATION ABOUT PROPELLER CRITICAL PARTS.

CAUTION 2: WHEN INSTALLING THE PROPELLER ON THE AIRCRAFT, DO NOT DAMAGE THE ICE PROTECTION SYSTEM COMPONENTS, IF APPLICABLE.

- (2) With a suitable crane hoist and sling, carefully move the propeller assembly to the aircraft engine mounting flange in preparation for installation.

D-2999

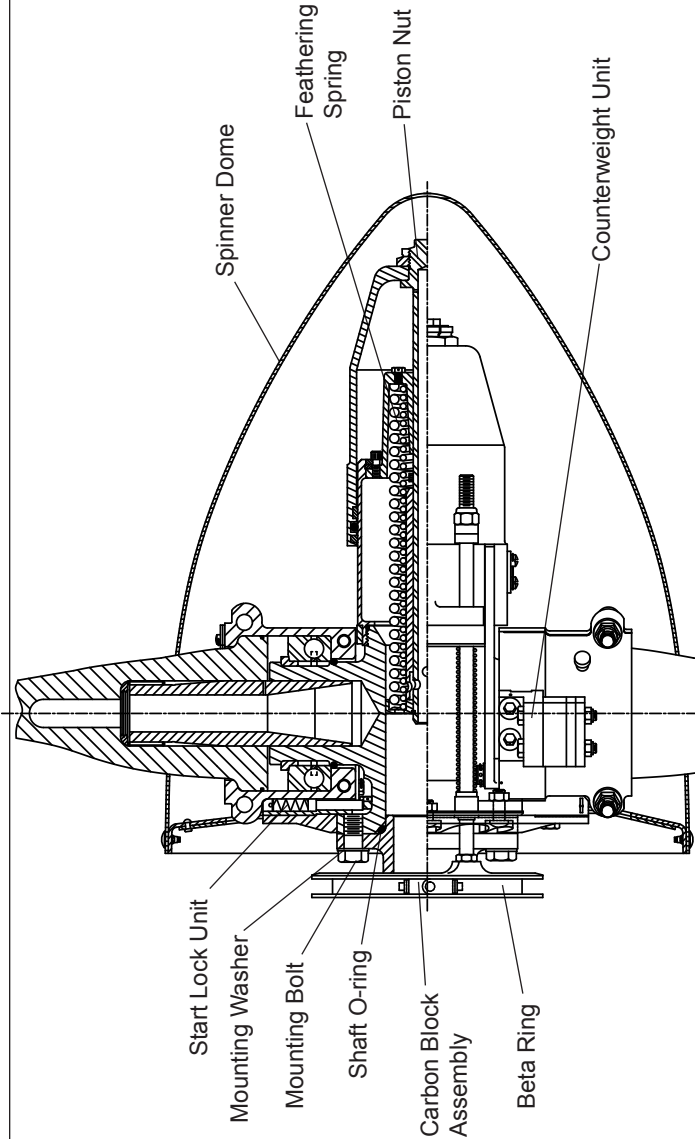

HC-92WF-5A Propeller Assembly
Figure 3-19

WARNING: ADHESIVES AND SOLVENTS ARE FLAMMABLE AND TOXIC TO THE SKIN, EYES, AND RESPIRATORY TRACT. SKIN AND EYE PROTECTION ARE REQUIRED. AVOID PROLONGED CONTACT AND BREATHING OF VAPORS. USE SOLVENT RESISTANT GLOVES TO MINIMIZE SKIN CONTACT AND WEAR SAFETY GLASSES FOR EYE PROTECTION. USE IN A WELL VENTILATED AREA AWAY FROM SPARKS AND FLAME. READ AND OBSERVE ALL WARNING LABELS.

- (3) Clean the engine flange and propeller flange with Quick Dry Stoddard Solvent or MEK.
- (4) Press fit two dowel pins through the holes in the propeller flange to be flush with the propeller side of the hub flange. Refer to Table 3-1 and Figure 3-20.
- (5) Install the specified O-ring on the engine flange. Refer to Table 3-1.
- (6) Align the mounting and dowel pin holes in the engine flange with the mounting holes and dowel pins in the propeller flange. Refer to Figure 3-20.
- (7) Slide the propeller flange onto the engine flange.

CAUTION 1: MAKE SURE THAT COMPLETE AND TRUE SURFACE CONTACT IS ESTABLISHED BETWEEN THE PROPELLER HUB FLANGE (OR SPACER) AND THE ENGINE FLANGE.

CAUTION 2: NEW PROPELLER MOUNTING BOLTS OR STUDS MUST BE USED WHEN INITIALLY INSTALLING A NEW OR OVERHAULED PROPELLER.

- (8) Install mounting bolts with washers through the engine flange and into the propeller hub flange. Refer to Table 3-1 and Figure 3-19.

NOTE: For propeller removals between overhaul intervals, mounting bolts and washers may be reused if they are not damaged or corroded.

- (9) Use a torque wrench with a torque wrench adapter Hartzell Propeller Inc. P/N AST-2814 to torque all mounting bolts in sequence in accordance with Table 3-2, Torque Values Table, Figure 3-2, and Figure 3-3 to determine the proper torque value to which the torque wrench must be set.
 - (a) Torque the mounting bolts to half of the final torque, beginning with any mounting bolt, and moving clockwise or counterclockwise until all the bolts are torqued.
 - (b) Final torque the bolts in sequence, beginning with any mounting bolt, and moving clockwise or counterclockwise until all the bolts are torqued.
- (10) Safety all mounting studs with 0.032 inch (0.81 mm) minimum diameter stainless steel wire or equivalent aircraft safety cable and associated hardware (two studs per safety).

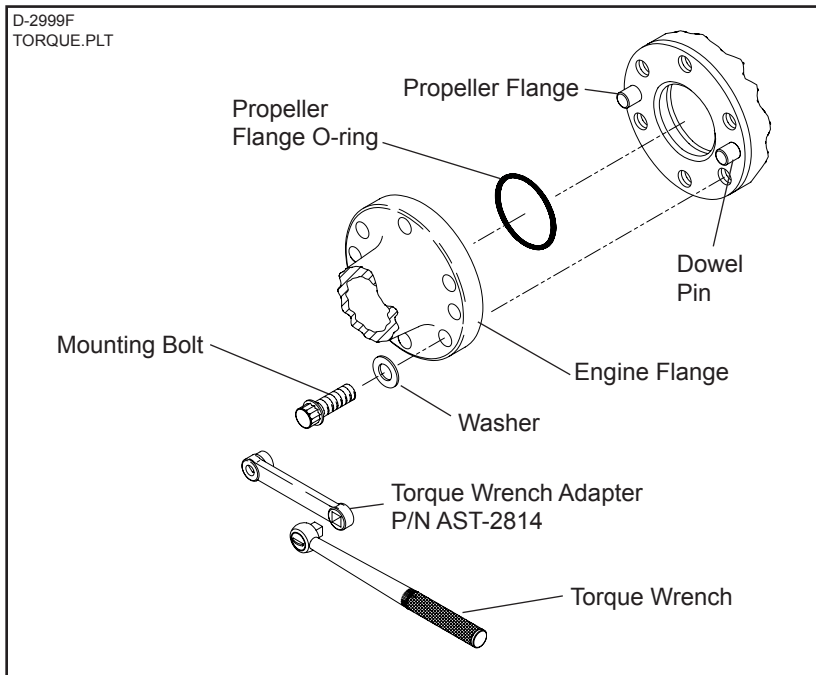

**HC-92WF-5A Installation
Figure 3-20**

- (11) Decompress and remove the beta system puller.
- (12) Install, adjust, and safety the beta linkage per the airframe manufacturer's instructions.
- (13) If the propeller is equipped with an ice protection system that uses components supplied by Hartzell Propeller Inc., applicable instructions and technical information for the components supplied by Hartzell Propeller Inc. can be found in the following publications available on the Hartzell Propeller Inc. web site at www.hartzellprop.com.
 - (a) Hartzell Propeller Inc. Manual 180 (30-61-80)
- Propeller Ice Protection System Manual
 - (b) Hartzell Propeller Inc. Manual 181 (30-60-81)
- Propeller Ice Protection System Component Maintenance Manual
 - (c) Hartzell Propeller Inc. Manual 182 (61-12-82)
- Propeller Electrical De-ice Boot Removal and Installation Manual
 - (d) Hartzell Propeller Inc. Manual 183 (61-12-83)
- Propeller Anti-icing Boot Removal and Installation Manual
- (14) Propeller ice protection system components not supplied by Hartzell Propeller Inc. are controlled by the applicable TC or STC holder's Instructions for Continued Airworthiness (ICA).
- (15) Install the spinner dome as follows:
 - NOTE:** The following instructions relate to Hartzell Propeller Inc. spinners only. In some cases, the airframe manufacturer produced the spinner assembly. In those cases, refer to the airframe manufacturer's manual for spinner installation instructions.

CAUTION 1: TO PREVENT DAMAGE TO THE BLADE AND BLADE PAINT, WRAP THE BLADE SHANKS IN SEVERAL LAYERS OF MASKING OR DUCT TAPE BEFORE INSTALLING THE SPINNER DOME. REMOVE THE TAPE AFTER THE SPINNER IS INSTALLED.

CAUTION 2: THE SPINNER DOME WILL WOBBLE IF NOT ALIGNED PROPERLY, AND MAY AFFECT THE BALANCE OF THE PROPELLER.

- (a) Carefully slide the spinner dome over the reassembled propeller.
- (b) Secure the spinner dome to the spinner bulkhead with the supplied screws and washers.

(16) Installation of the beta valve, governor, and linkage.
Refer to Figure 3-13 and Table 3-1.

- (a) Remove the four studs from the engine governor pad and install four new longer studs.
- (b) Install the governor gasket against the face of the engine pad.
- (c) Install the beta valve unit as shown in Figure 3-13.
- (d) Install a governor gasket against the valve face (contacting the governor).
- (e) Install the shaft extension into the female splines of the engine governor drive shaft.
- (f) Install the governor and secure it with nuts.

NOTE: Follow the applicable airframe manufacturer's instructions for the rigging of the governor control cable.

- (g) Torque the nuts to 18-20 Ft-Lb (25-27 N•m).
- (h) Install the carbon block into the beta linkage lever, per the airframe manufacturer's instructions.

CAUTION 1: FIT THE BLOCK IN THE BETA RING WITH A MINIMUM SIDE CLEARANCE OF 0.001 INCH (0.03 mm). REFER TO FIGURE 3-14.

CAUTION 2: MAXIMUM SIDE CLEARANCE PERMITTED IS 0.010 INCH (0.25 mm) IN ACCORDANCE WITH THE CARBON BLOCK ASSEMBLIES SECTION IN THE MAINTENANCE PRACTICES CHAPTER OF THIS MANUAL.

- (i) Install the carbon block assembly into the beta ring. Refer to Figure 3-15.
- (j) Attach the valve lever to the beta valve spool. Refer to Figure 3-13.
- (k) Install, adjust, and safety the beta linkage per the airframe manufacturer's instructions.

NOTE: If airframe manufacturer's instructions are unavailable, then follow step 4.J.(17).

- (l) Connect the outer end of the lever with the control push-pull fitting provided.
- (m) Attach the housing of the push-pull control to a bracket.

(17) Adjusting the Propeller Reverse Control System

Refer to Figure 3-16.

- (a) Set the reverse control in forward position.
- (b) Adjust "D", at the end of the reverse control rod, so that "B" is approximately 1/16 inch (1.6 mm) as measured from the spool flange to the bottom of the counterbore (or within 1/16 inch (1.6 mm) of the end of its travel).

NOTE: "A" is zero.

- (c) The low pitch adjustment "C" has been made at the factory according to published information. The readjustment of low pitch should not be required. Refer to the Propeller Low Pitch Setting section in the Maintenance Practices Chapter of this manual for adjustment information.

- (d) Check the runout of the beta ring by installing a dial indicator on the nose of the engine, so that it touches the rear face of the beta ring. If necessary, loosen nut "E" and rotate the rods to bring the runout to within 0.010 total indicator reading.
- (e) Torque nut "E" to 10-15 Ft-Lb (14-20 N•m).
- (f) Make sure the four low pitch adjusting nuts contact the piston bosses at the same time the piston is moved toward reverse pitch. To accomplish this:
 - 1 Equalize "C" for all four rods by means of accurate measurements. Refer to Figure 3-16.
 - 2 Adjust the nuts if necessary. This will make sure that the slip ring runs true during pitch reversal.

CAUTION: TO PREVENT ENGINE OVERSPEED, DO NOT PERMIT THE RPM TO REACH THE RPM SET BY THE GOVERNOR. THIS WILL PERMIT THE GOVERNOR TO OVERRIDE THE REVERSE PITCH CONTROL AND CAUSE THE PITCH TO COME OUT OF REVERSE.

- (g) Check the RPM during reverse pitch operation.
 - 1 Set the propeller governor control for maximum RPM.
 - 2 While the engine is idling, set the pitch control for maximum reverse pitch.
 - 3 Gradually open the throttle until the RPM reaches the maximum value, or until the RPM reaches approximately 80 percent to 90 percent of the engine rating.

NOTE: It is desirable to have the reverse pitch set to provide 80 percent to 90 percent of the engine rated RPM. This provides a margin of safety for reverse pitch operation.

CAUTION: DO NOT PUT THE BLADE PADDLE IN THE AREA OF THE DE-ICE BOOT WHEN APPLYING TORQUE TO A BLADE ASSEMBLY. PUT THE BLADE PADDLE IN THE THICKEST AREA OF THE BLADE, JUST OUTSIDE OF THE DE-ICE BOOT. USE ONE BLADE PADDLE PER BLADE.

- (h) If the RPM exceeds the desired value for reverse pitch, check to be sure the reverse push-pull control has enough travel to move the piston up against its internal stop. Refer to Figure 3-16. To accomplish this:
- 1 Using blade paddles (one per blade), rotate the blade angle into full reverse pitch, and determine if the beta valve is calling for oil pressure. This condition is met if "B" is 3/16 inch (4.8 mm) or less.
 - 2 While in full reverse, check for clearance between nut "E" and the guide bushing. There should be a positive clearance.

- K. Installing the 20 Spline HC-93Z20-1() Propeller Models
Refer to Figure 3-21.

WARNING: MAKE SURE THE SLING IS RATED UP TO 800 LBS. (363 KG) TO SUPPORT THE WEIGHT OF THE PROPELLER ASSEMBLY DURING INSTALLATION.

CAUTION 1: INSTRUCTIONS AND PROCEDURES IN THIS SECTION MAY INVOLVE PROPELLER CRITICAL PARTS. REFER TO THE INTRODUCTION CHAPTER OF THIS MANUAL FOR INFORMATION ABOUT PROPELLER CRITICAL PARTS.

CAUTION 2: WHEN INSTALLING THE PROPELLER ON THE AIRCRAFT, DO NOT DAMAGE THE ICE PROTECTION SYSTEM COMPONENTS, IF APPLICABLE.

- (1) With a suitable crane hoist and sling, carefully move the propeller assembly to the aircraft engine mounting flange.

NOTE: In most cases, the piston is not installed on the cylinder when the propeller is not installed on the engine.

- (2) If the piston is installed on the cylinder, perform the following steps:
- (a) Move the piston to low pitch and rotate the forks away from the clamp linkscrews.
 - (b) Remove the self-locking nut from the end of each guide rod.
 - (c) Remove the washer from each guide rod.
 - (d) Loosen the set screw in each fork.
 - (e) Lift the piston from the cylinder.
 - (f) Remove the sleeve from each bulkhead boss.
 - (g) Remove the high stop spacer from each sleeve.

- (h) The piston ears, forks, and counterweights should have corresponding index numbers (1,2, and 3) impression-stamped or marked with a felt-tipped pen. If they are not marked, number them with a felt-tipped pen.

NOTE: This will make sure that the components are reassembled in their original location.

WARNING: ADHESIVES AND SOLVENTS ARE FLAMMABLE AND TOXIC TO THE SKIN, EYES, AND RESPIRATORY TRACT. SKIN AND EYE PROTECTION ARE REQUIRED. AVOID PROLONGED CONTACT AND BREATHING OF VAPORS. USE SOLVENT RESISTANT GLOVES TO MINIMIZE SKIN CONTACT AND WEAR SAFETY GLASSES FOR EYE PROTECTION. USE IN A WELL VENTILATED AREA AWAY FROM SPARKS AND FLAME. READ AND OBSERVE ALL WARNING LABELS.

- (3) Clean the propeller hub spline and engine spline surfaces with Quick Dry Stoddard Solvent or MEK.
- (4) Slide rear spinner bulkhead onto the engine shaft.
- (5) Install the rear cone onto the bulkhead, matching the holes in the cone with the pins in the bulkhead. Push the cone against the bulkhead.
- (6) Install the rear cone O-ring over the shaft and against the cone. Refer to Table 3-1.
- (7) Slide the propeller hub onto the engine shaft and tighten the hub nut until the rear bulkhead is snug, but do not torque the nut.

CAUTION: TO PREVENT DAMAGE TO THE BLADE AND BLADE PAINT, WRAP THE BLADE SHANKS IN SEVERAL LAYERS OF MASKING OR DUCT TAPE BEFORE INSTALLING THE SPINNER DOME. REMOVE THE TAPE AFTER THE SPINNER IS INSTALLED.

- (8) Carefully slide the spinner dome over the installed propeller.

D-1375

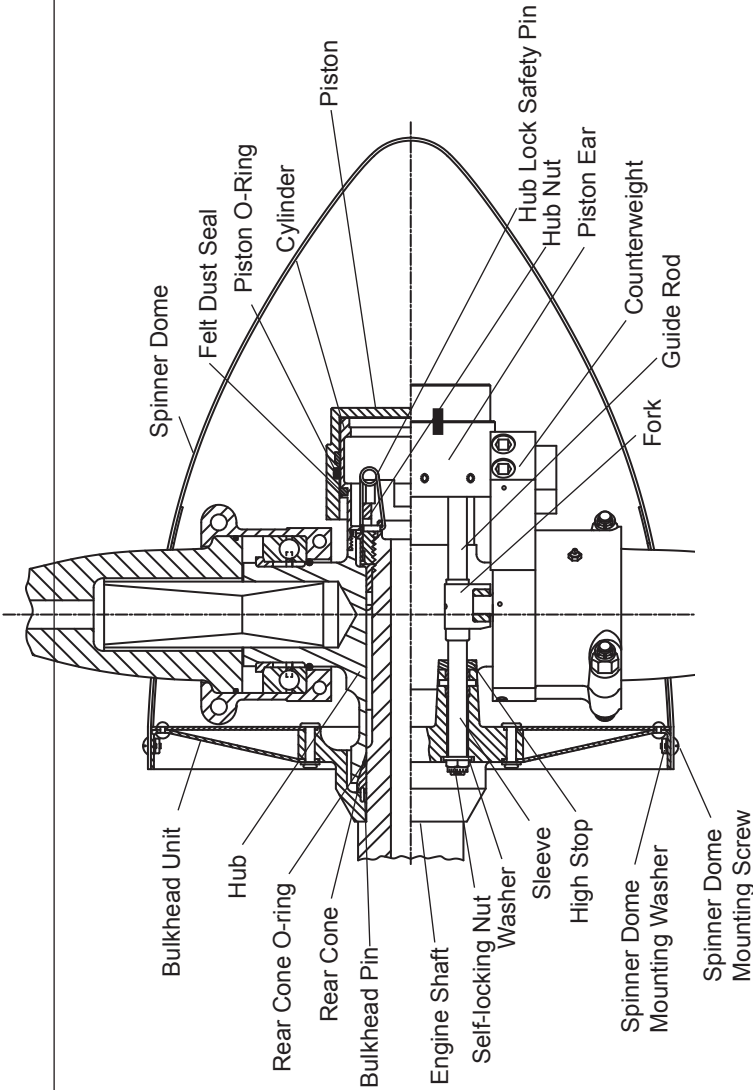

HC-93Z20-1() Propeller Assembly
Figure 3-21

- (9) To properly position the rear bulkhead, temporarily install the spinner dome using at least three screws.
- (10) Adjust the spinner to equalize the clearance between the blades and the blade cutouts in the dome.
- (11) Remove the spinner dome.
- (12) Using Hartzell Propeller Inc. Tool BST-2910, torque the propeller shaft nut in accordance with Table 3-2, Torque Values Table and Figure 3-3 to determine the proper torque value to which the torque wrench must be set.
- (13) Safety the hub nut using the hub lock safety pin. Refer to Table 3-1 and Figure 3-21.
- (14) If the piston O-ring and the felt dust seal are not already installed in the piston, perform the following steps: Refer to Table 3-1 and Figure 3-22.
 - (a) Using aviation grade reciprocating engine oil, lubricate the piston O-ring and carefully install it in the groove provided for it in the piston.
 - (b) Soak the felt dust seal in aviation grade reciprocating engine oil until the seal is completely saturated.
 - (c) Squeeze the excess oil from the felt dust seal.

CAUTION: MAKE SURE THAT THE FELT DUST SEAL IS FREE OF FUZZ.

- (d) If the felt dust seal has fuzz or long strands that could interfere with the O-ring operation, replace the felt dust seal.
- (e) Cut the oiled felt dust seal material to the necessary length.
 - 1 The felt seal material should be cut on a 30 degree diagonal so there will be an overlap with a smooth, fuzz-free surface.
- (f) Install the felt dust seal material in the groove provided for it in the piston.

CAUTION: TO MAINTAIN PROPER BLADE BALANCE, IT IS IMPORTANT THAT THE PISTON BE REINSTALLED IN THE SAME POSITION AS WHEN IT WAS ORIGINALLY ASSEMBLED. INDEX NUMBERS ON THE PISTON AND THE GUIDE COLLAR ARE PROVIDED TO INSURE PROPER POSITIONING.

(15) Locate and match up the index numbers (1, 2 and 3) on the forks and piston ears with the corresponding index numbers on the counterweights.

NOTE: The index marks will be either impression stamped or drawn with a felt-tipped pen.

(16) Install the high stop spacers (Table 3-1) on each rod sleeve.

(17) Slide the rod sleeves with high stop spacers into each spinner bulkhead boss.

(18) Oil the entire surface of the cylinder.

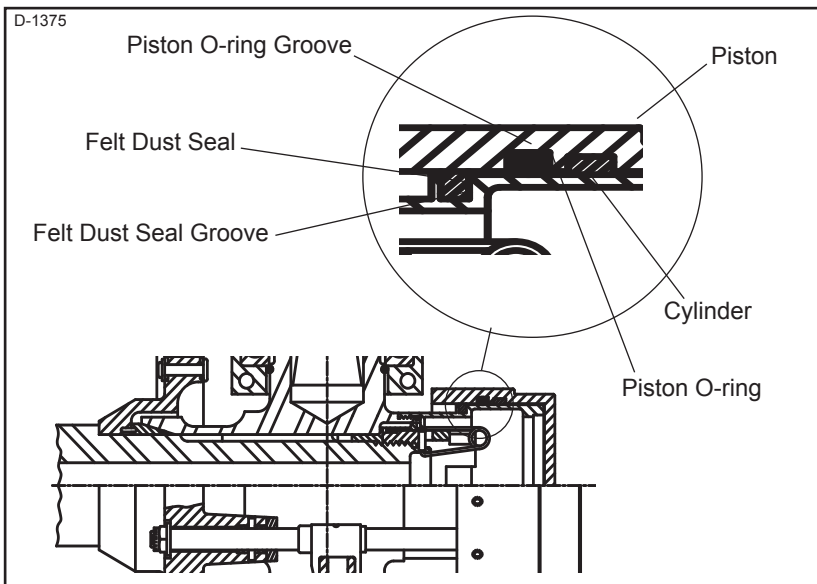

**Installing Piston O-ring and Felt Dust Seal
Figure 3-22**

(19) Install the pitch change block on each clamp linkscrew.

CAUTION: POSITION THE THICK SIDE OF THE FORK ON THE ENGINE SIDE OF THE PITCH CHANGE BLOCK.

(20) Slide a fork onto each pitch change block.

(21) Slide the guide rods through the forks and rod sleeves until the piston rods protrude through the spinner bulkhead.

(22) Install the washer and self-locking nut on the end of each of the guide rods. Refer to Figure 3-1.

NOTE: Align the forks with the pitch change blocks.

(23) Torque the self-locking nut against the guide rod. Refer to Table 3-2.

(24) Torque the set screw in each fork.

(25) Safety the set screws.

(26) If the propeller is equipped with an ice protection system that uses components supplied by Hartzell Propeller Inc., applicable instructions and technical information for the components supplied by Hartzell Propeller Inc. can be found in the following publications available on the Hartzell Propeller Inc. web site at www.hartzellprop.com.

(a) Hartzell Propeller Inc. Manual 180 (30-61-80)
- Propeller Ice Protection System Manual

(b) Hartzell Propeller Inc. Manual 181 (30-60-81)
- Propeller Ice Protection System Component Maintenance Manual

(c) Hartzell Propeller Inc. Manual 182 (61-12-82)
- Propeller Electrical De-ice Boot Removal and Installation Manual

(d) Hartzell Propeller Inc. Manual 183 (61-12-83)
- Propeller Anti-icing Boot Removal and Installation Manual

(27) Propeller ice protection system components not supplied by Hartzell Propeller Inc. are controlled by the applicable TC or STC holder's Instructions for Continued Airworthiness (ICA).

(28) Install the spinner dome as follows:

NOTE: The following instructions relate to Hartzell Propeller Inc. spinners only. In some cases, the airframe manufacturer produced the spinner assembly. In those cases, refer to the airframe manufacturer's manual for spinner installation instructions.

CAUTION 1: TO PREVENT DAMAGE TO THE BLADE AND BLADE PAINT, WRAP THE BLADE SHANKS IN SEVERAL LAYERS OF MASKING OR DUCT TAPE BEFORE INSTALLING THE SPINNER DOME. REMOVE THE TAPE AFTER THE SPINNER IS INSTALLED.

CAUTION 2: THE SPINNER DOME WILL WOBBLE IF NOT ALIGNED PROPERLY, AND MAY AFFECT THE BALANCE OF THE PROPELLER.

- (a) Carefully slide the spinner dome over the installed propeller.
- (b) Secure the spinner dome to the spinner bulkhead with the supplied screws and washers.

- L. Installing the 20 Spline HC-93Z20-2() and the 30 Spline HC-93Z30-2() Propeller Models

Refer to Figures 3-23 through 3-25.

WARNING 1: TO FACILITATE BOXING AND SHIPPING OF THE PROPELLER, THE PISTON NUT SHOULD HAVE BEEN REMOVED IN ORDER TO PERMIT ROTATING OF THE BLADES BEFORE PACKAGING.

FOR SAFETY REASONS, IF THE PISTON NUT WAS NOT REMOVED (HC-B3[]30-2E [] MODELS ONLY), THE PROPELLER MUST BE PUT IN FEATHER POSITION BEFORE IT IS INSTALLED ON THE AIRCRAFT.

WARNING 2: MAKE SURE THE SLING IS RATED UP TO 800 LBS. (363 KG) TO SUPPORT THE WEIGHT OF THE PROPELLER ASSEMBLY DURING INSTALLATION.

CAUTION 1: INSTRUCTIONS AND PROCEDURES IN THIS SECTION MAY INVOLVE PROPELLER CRITICAL PARTS. REFER TO THE INTRODUCTION CHAPTER OF THIS MANUAL FOR INFORMATION ABOUT PROPELLER CRITICAL PARTS.

CAUTION 2: WHEN INSTALLING THE PROPELLER ON THE AIRCRAFT, DO NOT DAMAGE THE ICE PROTECTION SYSTEM COMPONENTS, IF APPLICABLE.

- (1) With a suitable crane hoist and sling, carefully move the propeller assembly to the aircraft engine shaft.

CAUTION: THE PISTON MUST BE REMOVED BEFORE INSTALLING THE PROPELLER ON THE AIRCRAFT. IF THE PISTON HAS ALREADY BEEN REMOVED, PROCEED TO STEP 4.K.(4).

(2) Piston Removal (Refer to Figures 3-23 through 3-25).

- (a) Remove the piston nut, if it was not previously removed to facilitate boxing and shipping of the propeller. Refer to Table 3-1.
- (b) Remove the safety wire (if installed) from the link pin units.
- (c) Remove the safety screw from each link pin unit.
- (d) Remove each link pin unit.
- (e) The piston ears and guide collar should have corresponding index numbers (1, 2, and 3) impression stamped or marked with a felt-tipped pen. If they are not marked, number them with a felt-tipped pen.

NOTE: This will insure that the components are reassembled in their original location.

- (f) Slide the link arms out of the piston slots.
- (g) Remove the socket head cap screw, jam nut, and washer from each piston guide rod. Refer to Table 3-1.
- (h) Slide the piston off the cylinder.

CAUTION: THE SPRING ASSEMBLY MUST BE REMOVED BEFORE INSTALLING THE PROPELLER ON THE AIRCRAFT. IF THE SPRING ASSEMBLY HAS ALREADY BEEN REMOVED, PROCEED TO STEP 4.L.(5).

(3) Spring assembly removal

- (a) Configuration A - Propeller model HC-93Z20-2C1
 - 1 Remove the ring retention plate screw safety wire (if installed).
 - 2 Remove the ring retention plate screws.
 - 3 Remove the retention plate.
 - 4 Remove the split retainer.

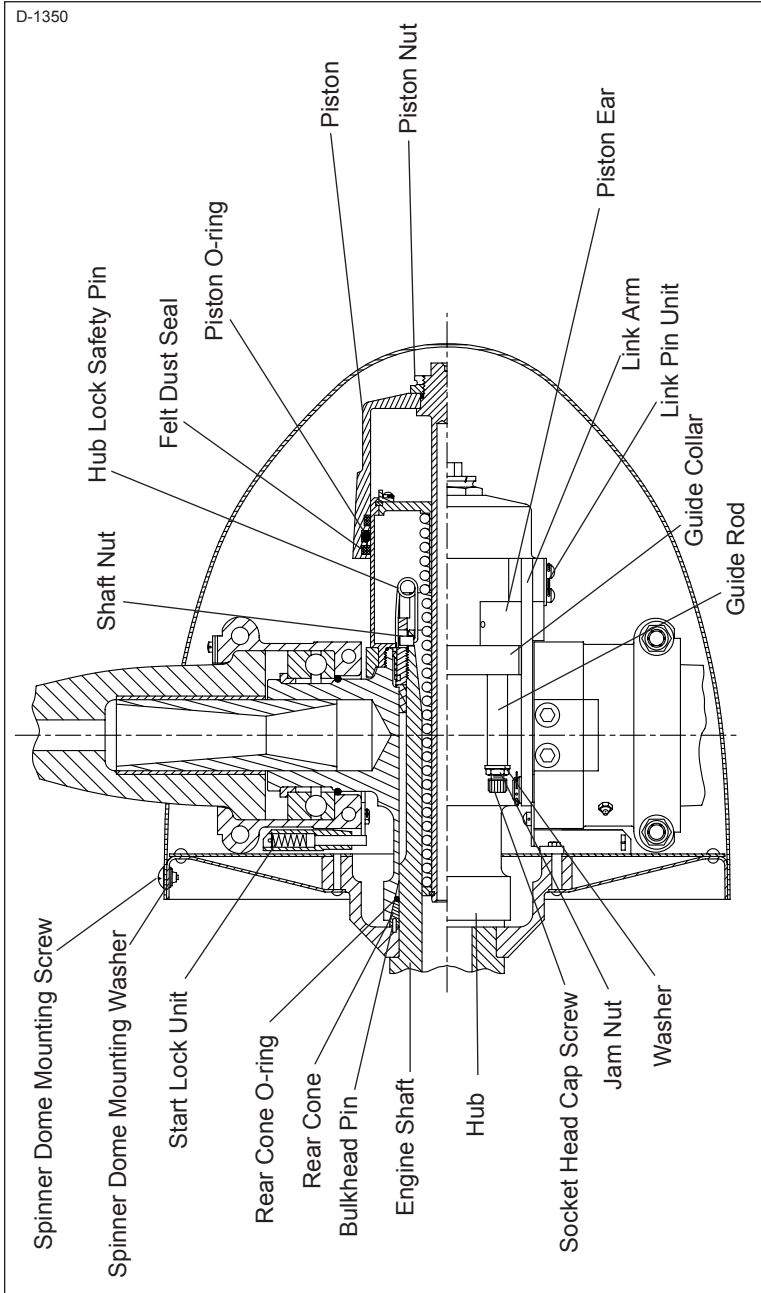

HC-93Z20-2A(1), -2B, -2C, -2D1 Propeller Assembly
Figure 3-23

D-1396

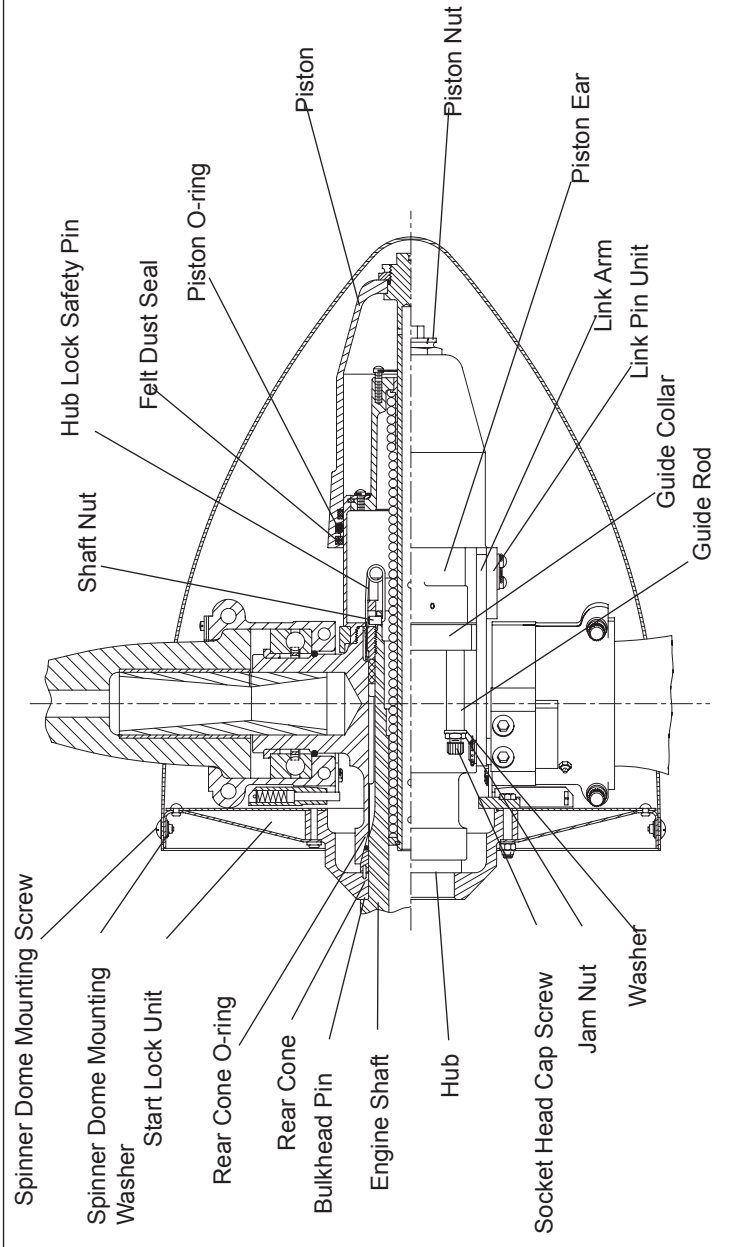

HC-93Z20-2C1 Propeller Assembly
Figure 3-24

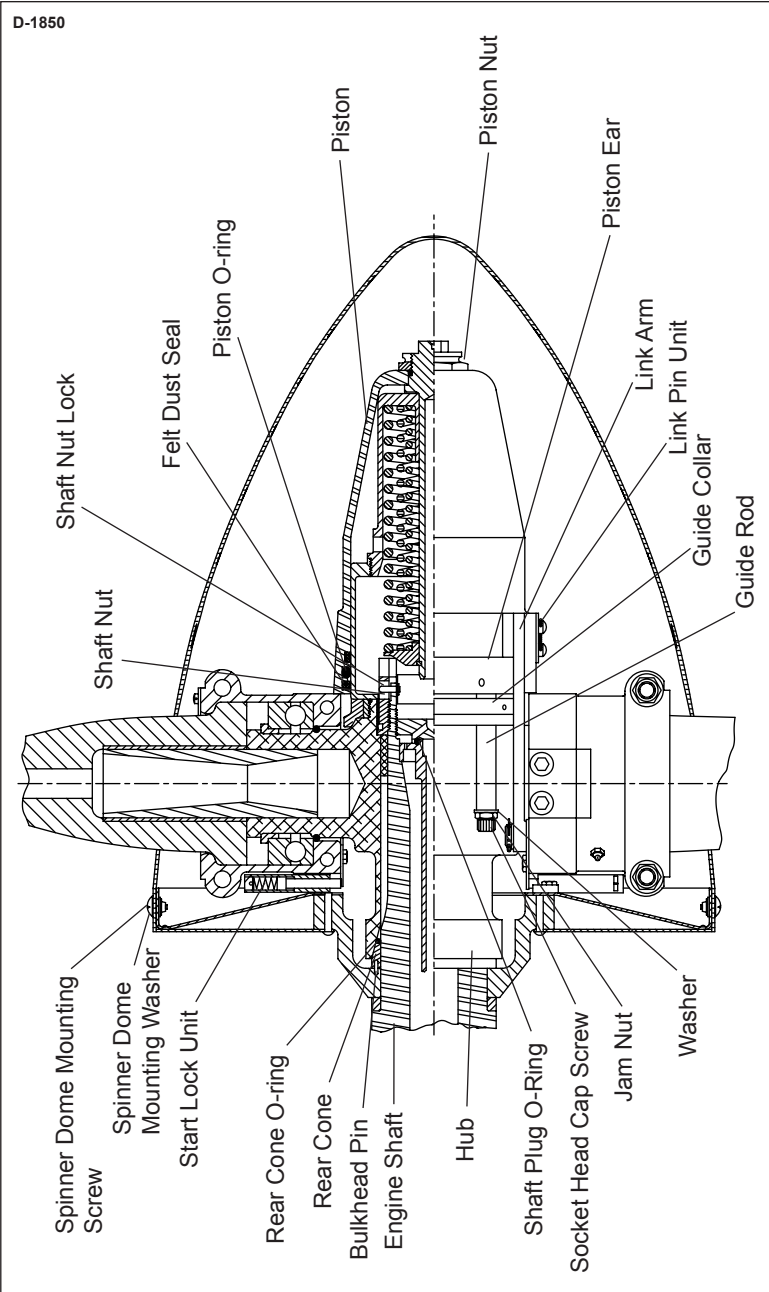

HC-93Z30-2E Propeller Assembly
Figure 3-25

- 5 Remove the spring assembly from the cylinder.
- (b) Configuration B - Propeller model HC-93Z30-2E
- 1 Remove the safety wire (if installed).
 - 2 Using a spanner wrench BT-461 or strap wrench 100923, unthread the spring retainer from the cylinder. Refer to Figure 3-28.
 - 3 Remove the spring retainer and the attached spring assembly from the cylinder.
- (c) Configuration C - Propeller models HC-93Z20-2A(1),-2B,-2C,-2D1, and HC-93Z30-2B
- 1 Remove the safety wire (if installed).
 - 2 Remove two screws from each of two feather stops on the front spring retainer.
 - 3 Remove the feather stops.
 - 4 Remove the split retainer.
 - 5 Remove the spring assembly from the cylinder.

WARNING: ADHESIVES AND SOLVENTS ARE FLAMMABLE AND TOXIC TO THE SKIN, EYES, AND RESPIRATORY TRACT. SKIN AND EYE PROTECTION ARE REQUIRED. AVOID PROLONGED CONTACT AND BREATHING OF VAPORS. USE SOLVENT RESISTANT GLOVES TO MINIMIZE SKIN CONTACT AND WEAR SAFETY GLASSES FOR EYE PROTECTION. USE IN A WELL VENTILATED AREA AWAY FROM SPARKS AND FLAME. READ AND OBSERVE ALL WARNING LABELS.

- (4) Clean the propeller hub spline and engine spline surfaces with Quick Dry Stoddard Solvent or MEK.
- (5) On 30 spline shaft models only, slide the spacers (as required) onto the shaft. Refer to Table 3-1 and Figure 3-29.
- (6) Slide the spinner bulkhead onto the shaft.
- (7) Install the rear cone onto the bulkhead, matching the holes in the cone with the pins in the bulkhead. Refer to Figure 3-29.

- (8) Install the rear cone O-ring over the shaft and against the cone. Refer to Table 3-1 and Figure 3-23.
- (9) On HC-93Z30-2E propeller model only, install the plug O-ring in the groove of the shaft plug, and install the shaft plug and O-ring in the engine shaft. Refer to Table 3-1 and Figure 3-29.
- (10) Slide the propeller hub onto the shaft and tighten the shaft nut until the rear bulkhead is snug, but do not torque the nut.

CAUTION: TO PREVENT DAMAGE TO THE BLADE AND BLADE PAINT, WRAP THE BLADE SHANKS IN SEVERAL LAYERS OF MASKING OR DUCT TAPE BEFORE POSITIONING THE SPINNER BULKHEAD OR INSTALLING THE SPINNER DOME. REMOVE THE TAPE AFTER THE SPINNER IS INSTALLED.

- (11) Carefully slide the spinner dome over the installed propeller.
- (12) To properly position the rear bulkhead, temporarily install the spinner dome with at least three screws.

NOTE: Make sure the start lock pins are parallel with the blade axis, but offset to one side.

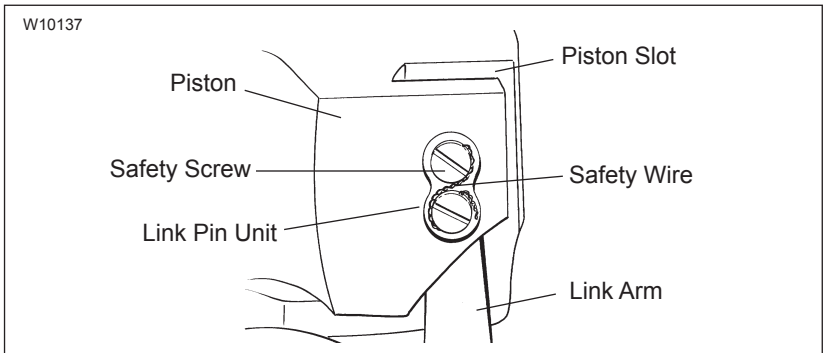

**Piston-to-Link Arm Attachment Details
Figure 3-26**

(13) Adjust the spinner to equalize the clearance between the blades and the blade cutouts in the dome.

(14) Remove the spinner dome.

(15) Using tool BST-2910, torque the propeller shaft nut in accordance with Table 3-2, Torque Values Table, Table 3-1, and Figure 3-5 to determine the proper torque value to which the torque wrench must be set.

(16) Safety the shaft nut to the engine shaft using a hub lock safety pin for 20 spline models, or a shaft nut lock for 30 spline models. Refer to Table 3-1 and Figure 3-30.

NOTE: The hub lock safety pin or the shaft nut lock are normally supplied in a separate package when the propeller is shipped new from the factory.

(17) Install the spring assembly. Refer to Figure 3-27.

(a) Configuration A - Propeller model HC-93Z20-2C1

- 1 Put the feathering spring assembly into the engine shaft, with the front spring retainer inside the cylinder.
- 2 Install the split retainer between the cylinder and the front spring retainer, sliding the split retainer into the recess in the cylinder.
- 3 Pull the spring retainer tight against the split retainer.
- 4 Install the ring retainer plate that secures the split retainer, into place.
- 5 Install the ring retention screws and tighten them until they are snug.
- 6 Safety the stop plate screws with 0.032 inch (0.81 mm) minimum diameter stainless steel wire (two per safety).

(b) Configuration B - Propeller model HC-93Z30-2E

- 1 Insert the feathering spring assembly into the cylinder.
- 2 Using a spanner wrench BT-461 (Figure 3-28) or strap wrench 100923, thread the feathering spring into place in the cylinder.

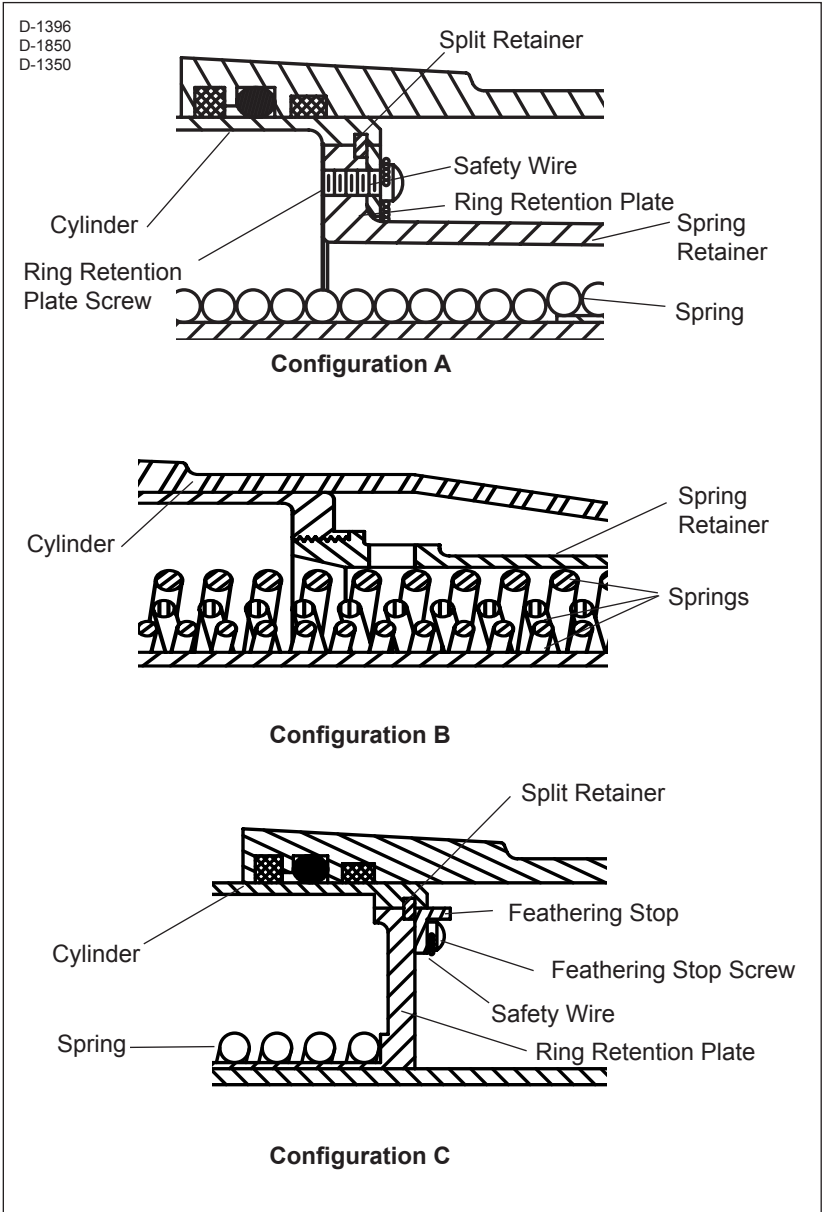

Spring Assembly-to-Cylinder Attachment Details
Figure 3-27



APS0190
APS0211

Spanner Wrench
BT-461

NOTE: May use Strap
Wrench 100923 as
alternate

Number
51 Drill bit
(0.067 inch
[1.70 mm]
diameter)

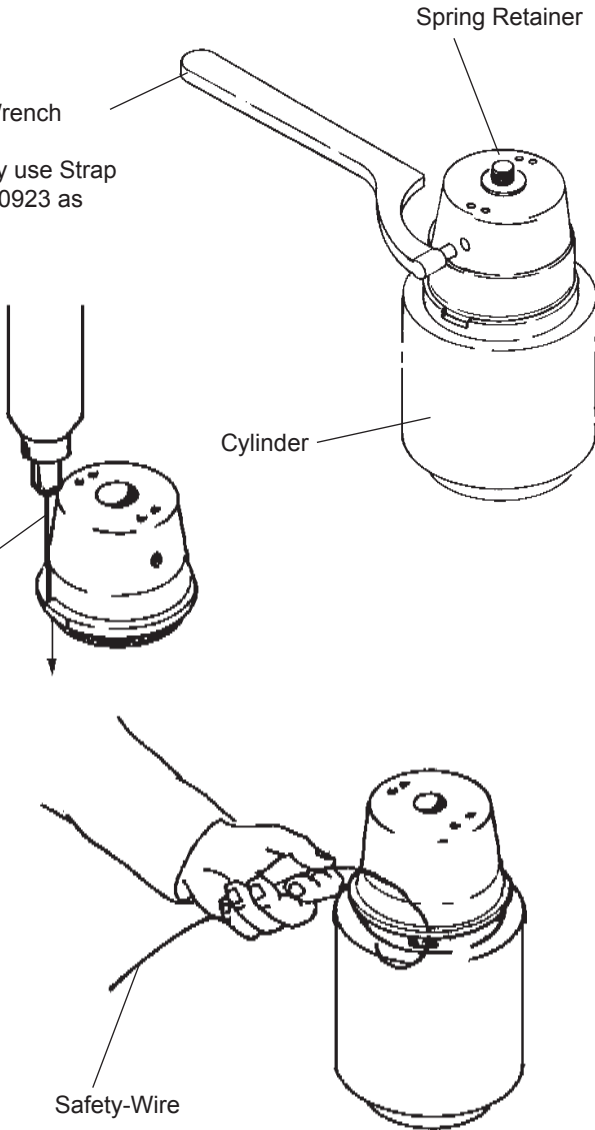

Feathering Spring Assembly
Figure 3-28

D-1350
D-1820

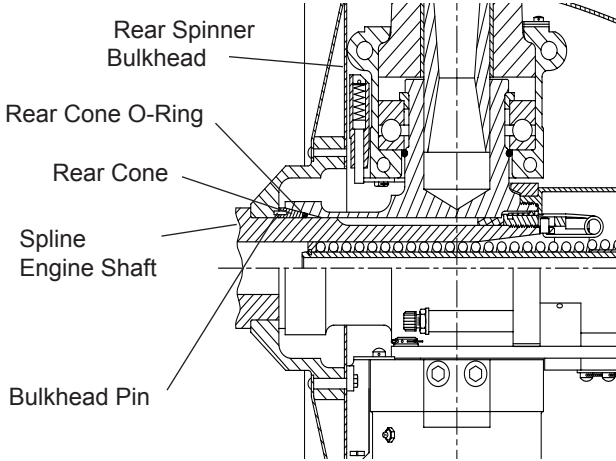

20 Spline Shaft Propellers

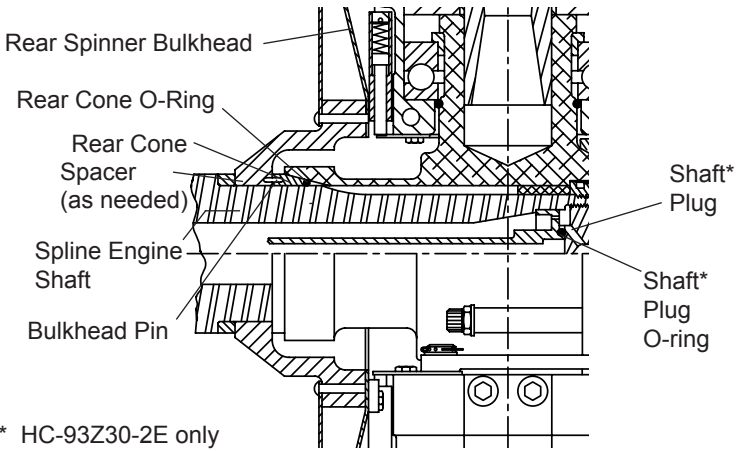

30 Spline Shaft Propellers

**Rear Hub Mounting Parts on 30-Spline Shaft Propeller
Figure 3-29**

- 3 Torque the feathering spring assembly in accordance with Table 3-2, Torque Values Table and Figure 3-5 to determine the proper torque value to which the torque wrench must be set.
 - 4 Using a number 51 drill (0.067 inch [1.70 mm] diameter), drill a hole through the lip on the spring cup to line up with the slot in the cylinder Refer to Figure 3-28.
 - 5 Insert 0.032 inch (0.81 mm) minimum diameter stainless steel wire through the hole in the spring cup, matching it with the slots in the cylinder Refer to Figure 3-28.
- (c) Configuration C - Propeller models HC-93Z20-2A(1), -2B, -2C, -2D1, and HC-93Z30-2B
- 1 Put the feathering spring assembly into the engine shaft, with the front spring retainer inside the cylinder.
 - 2 Install the split retainer between the cylinder and the front spring retainer, sliding the split retainer into the recess in the cylinder.
 - 3 Locate the two feathering stops, on the front spring retainer, that secure the split retainer into place.
 - 4 Install the feathering stop retention screws and tighten them until they are snug.
 - 5 Safety the stop plate screws with 0.032 inch (0.81 mm) minimum diameter stainless steel wire (two per safety).
- (18) If the piston O-ring and the felt dust seal are not already installed in the piston, perform the following steps. Refer to Table 3-1 and Figure 3-22.
- (a) Using aviation grade reciprocating engine oil, lubricate the piston O-ring and carefully install it in the groove provided for it in the piston.
 - (b) Soak the felt dust seal in aviation grade reciprocating engine oil until the seal is completely saturated.
 - (c) Squeeze the excess oil from the felt dust seal.

W10135
W10140

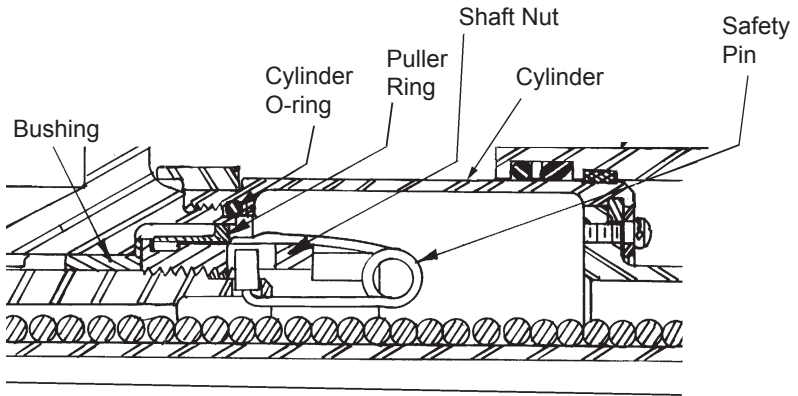

Safety Pin on 20 Spline Shaft Models

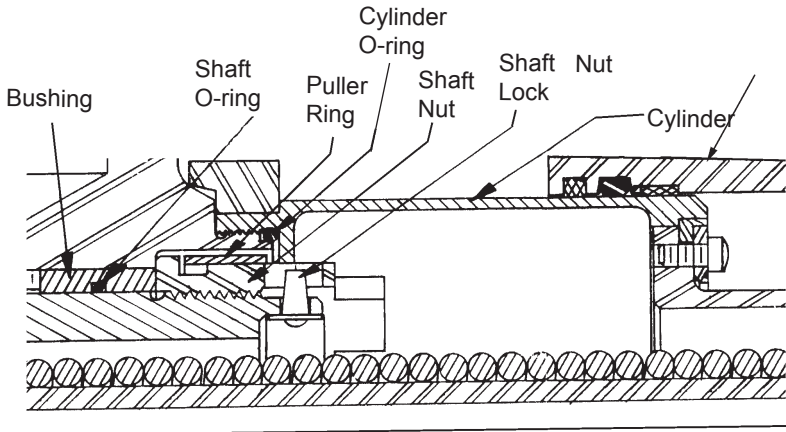

Shaft Nut Lock on 30 Spline Shaft Models

**Safelying the Shaft Nut on a Splined Shaft Propeller
Figure 3-30**



CAUTION: MAKE SURE THAT THE FELT DUST SEAL IS FREE OF FUZZ.

- (d) If the felt dust seal has fuzz or long strands that could interfere with the O-ring operation, replace the felt dust seal.
- (e) Cut the oiled felt dust seal material to the necessary length.
 - 1 The felt seal material should be cut on a 30 degree diagonal so there will be an overlap with a smooth, fuzz-free surface.
- (f) Install the felt dust seal material in the groove provided for it in the piston.
- (e) Install the rod O-ring in the groove at the end of the threaded portion of the pitch change rod. Refer to Table 3-1.

CAUTION: TO MAINTAIN PROPER BLADE ANGLES, IT IS IMPORTANT THAT THE PISTON BE REINSTALLED IN THE SAME POSITION AS WHEN IT WAS ORIGINALLY ASSEMBLED. INDEX NUMBERS ON THE PISTON AND THE GUIDE COLLAR ARE PROVIDED TO INSURE PROPER POSITIONING.

(19) Locate and match up the index numbers (1, 2 and 3) on the piston ears with the corresponding index numbers on the guide collar.

NOTE: The index marks will be either impression stamped or drawn with a felt-tipped pen.

- (20) Oil the surface of the cylinder and install the piston.
- (21) Slide the piston onto the cylinder and pass the guide rods through the collar bushing.
- (22) Install the washer, socket head cap screw, and jam nut, at the end of each guide rod. Refer to Table 3-1, and Figures 3-23 through 3-25.
- (23) Connect the link arms to the piston. Refer to Figure 3-26.
- (24) Install the link pin units. Refer to Figure 3-26.
- (25) Install the link pin safety screws. Refer to Figure 3-26.

- (26) Safety the two screws together with 0.032 inch (0.81 mm) minimum diameter stainless steel wire. Refer to Figure 3-26.
- (27) Carefully rotate the blades into feather position and fasten the piston to the pitch change rod with the piston nut. Refer to Table 3-1.
- (28) Torque the piston nut in accordance with Table 3-2, Torque Values Table.
- (29) Torque the jam nut against the guide rod in accordance with Table 3-2, Torque Values Table.
- (30) Remove the wires from the start lock brackets.
- (31) Position the propeller on the start locks.

CAUTION: DO NOT PUT THE BLADE PADDLE IN THE AREA OF THE DE-ICE BOOT WHEN APPLYING TORQUE TO A BLADE ASSEMBLY. PUT THE BLADE PADDLE IN THE THICKEST AREA OF THE BLADE, JUST OUTSIDE OF THE DE-ICE BOOT. USE ONE BLADE PADDLE PER BLADE.

- (32) Using the paddles, simultaneously rotate the blades toward low pitch until the start lock pins engage the stop plate.
- (33) If the propeller is equipped with an ice protection system that uses components supplied by Hartzell Propeller Inc., applicable instructions and technical information for the components supplied by Hartzell Propeller Inc. can be found in the following publications available on the Hartzell Propeller Inc. web site at www.hartzellprop.com.
 - (a) Hartzell Propeller Inc. Manual 180 (30-61-80)
- Propeller Ice Protection System Manual
 - (b) Hartzell Propeller Inc. Manual 181 (30-60-81)
- Propeller Ice Protection System Component Maintenance Manual
 - (c) Hartzell Propeller Inc. Manual 182 (61-12-82)
- Propeller Electrical De-ice Boot Removal and Installation Manual
 - (d) Hartzell Propeller Inc. Manual 183 (61-12-83)
- Propeller Anti-icing Boot Removal and Installation Manual

(34) Propeller ice protection system components not supplied by Hartzell Propeller Inc. are controlled by the applicable TC or STC holder's Instructions for Continued Airworthiness (ICA).

(35) Install the spinner dome as follows:

NOTE: The following instructions relate to Hartzell Propeller Inc. spinners only. In some cases, the airframe manufacturer produced the spinner assembly. In those cases, refer to the airframe manufacturer's manual for spinner installation instructions.

CAUTION 1: TO PREVENT DAMAGE TO THE BLADE AND BLADE PAINT, WRAP THE BLADE SHANKS IN SEVERAL LAYERS OF MASKING OR DUCT TAPE BEFORE INSTALLING THE SPINNER DOME. REMOVE THE TAPE AFTER THE SPINNER IS INSTALLED.

CAUTION 2: THE SPINNER DOME WILL WOBBLE IF NOT ALIGNED PROPERLY, AND MAY AFFECT THE BALANCE OF THE PROPELLER.

- (a) Carefully slide the spinner dome over the reassembled propeller.
- (b) Secure the spinner dome to the spinner bulkhead with the supplied screws and washers.

5. Post-Installation Checks

- A. Refer to the airframe manufacturer's instructions for post-installation checks.
- B. Perform a static RPM check as outlined in the Maintenance Practices chapter of this manual.

6. Propeller Assembly Removal

- A. Removing the F Flange Propeller Models BHC-92()F-1D1
Refer to Figure 3-1.

NOTE: If the propeller is equipped with an anti-ice or a de-ice system, follow the manufacturer's instructions for removing the components necessary for propeller removal.

CAUTION 1: INSTRUCTIONS AND PROCEDURES IN THIS SECTION MAY INVOLVE PROPELLER CRITICAL PARTS. REFER TO THE INTRODUCTION CHAPTER OF THIS MANUAL FOR INFORMATION ABOUT PROPELLER CRITICAL PARTS.

CAUTION 2: TO PREVENT DAMAGE TO THE BLADE AND BLADE PAINT, WRAP THE BLADE SHANKS IN SEVERAL LAYERS OF MASKING OR DUCT TAPE BEFORE REMOVING THE SPINNER DOME.

(1) Spinner dome removal

- (a) Remove the screws and washers that secure the spinner dome to the spinner bulkhead.
- (b) Remove the spinner dome.

WARNING 1: DURING ENGINE INSTALLATION OR REMOVAL, USING THE PROPELLER TO SUPPORT THE WEIGHT OF THE ENGINE IS NOT AUTHORIZED. UNAPPROVED INSTALLATION AND REMOVAL TECHNIQUES MAY CAUSE DAMAGE TO THE PROPELLER THAT MAY LEAD TO FAILURE AND RESULT IN AN AIRCRAFT ACCIDENT.

WARNING 2: DURING PROPELLER REMOVAL, AIRFRAME MANUFACTURER'S MANUALS AND PROCEDURES MUST BE FOLLOWED BECAUSE THEY MAY CONTAIN ISSUES VITAL TO AIRCRAFT SAFETY THAT ARE NOT CONTAINED IN THIS MANUAL OR IN THE HARTZELL PROPELLER INC. PROPELLER OVERHAUL MANUALS.

WARNING 3: MAKE SURE THE SLING IS RATED UP TO 800 POUNDS (363 KG.) TO SUPPORT THE WEIGHT OF THE PROPELLER ASSEMBLY DURING REMOVAL.

- (2) Support the propeller assembly with a sling.
- (3) Cut and remove the safety wire on the propeller mounting bolts.

CAUTION: DISCARD THE PROPELLER MOUNTING BOLTS IF THEY ARE DAMAGED OR CORRODED, OR IF THE PROPELLER IS REMOVED FOR OVERHAUL.

- (4) Remove the propeller mounting bolts and washers.

NOTE: For propeller removals between overhaul intervals, mounting bolts and washers may be reused if they are not damaged or corroded.

CAUTION: USE ADEQUATE PRECAUTIONS TO PROTECT THE PROPELLER ASSEMBLY FROM DAMAGE WHEN IT IS REMOVED FROM THE AIRCRAFT ENGINE AND WHEN IT IS STORED.

- (5) Using the support sling, lift the propeller from the mounting flange.
 - (6) Remove the spinner attaching nuts and bolts that hold the spinner bulkhead, spinner mounting ring, and spinner mounting plate together.
 - (7) Remove the spinner bulkhead, spinner mounting ring, and spinner mounting plate.
 - (8) Remove and discard the engine shaft O-ring.
 - (9) Put the propeller and associated parts on a suitable cart for transportation.
- B. Removing the F Flange Propeller Models HC-92()F-8()
Refer to Figure 3-4.

NOTE: If the propeller is equipped with an anti-ice or a de-ice system, follow the manufacturer's instructions for removing the components necessary for propeller removal.

CAUTION 1: INSTRUCTIONS AND PROCEDURES IN THIS SECTION MAY INVOLVE PROPELLER CRITICAL PARTS. REFER TO THE INTRODUCTION CHAPTER OF THIS MANUAL FOR INFORMATION ABOUT PROPELLER CRITICAL PARTS.

CAUTION 2: TO PREVENT DAMAGE TO THE BLADE AND BLADE PAINT, WRAP THE BLADE SHANKS IN SEVERAL LAYERS OF MASKING OR DUCT TAPE BEFORE REMOVING THE SPINNER DOME.

- (1) Spinner dome removal
 - (a) Remove the screws and washers that secure the spinner dome to the spinner bulkhead.
 - (b) Remove the spinner dome.

WARNING 1: DURING ENGINE INSTALLATION OR REMOVAL, USING THE PROPELLER TO SUPPORT THE WEIGHT OF THE ENGINE IS NOT AUTHORIZED. UNAPPROVED INSTALLATION AND REMOVAL TECHNIQUES MAY CAUSE DAMAGE TO THE PROPELLER THAT MAY LEAD TO FAILURE AND RESULT IN AN AIRCRAFT ACCIDENT.

WARNING 2: DURING PROPELLER REMOVAL, AIRFRAME MANUFACTURER'S MANUALS AND PROCEDURES MUST BE FOLLOWED BECAUSE THEY MAY CONTAIN ISSUES VITAL TO AIRCRAFT SAFETY THAT ARE NOT CONTAINED IN THIS MANUAL OR IN THE HARTZELL PROPELLER INC. PROPELLER OVERHAUL MANUALS.

(2) Cut and remove the safety wire on the propeller mounting bolts.

WARNING: MAKE SURE THE SLING IS RATED UP TO 800 POUNDS (363 KG.) TO SUPPORT THE WEIGHT OF THE PROPELLER ASSEMBLY DURING REMOVAL.

(3) Support the propeller assembly with a sling.

NOTE 1: Supporting the propeller with the sling may be delayed until all but two mounting bolts and washers have been removed to permit propeller rotation for ease of nut removal.

NOTE 2: If the propeller will be reinstalled, and it has been dynamically balanced, make an identifying mark on the propeller hub and a matching mark on the engine flange to make sure of proper orientation during re-installation to prevent dynamic imbalance.

CAUTION: DISCARD THE PROPELLER MOUNTING BOLTS IF THEY ARE DAMAGED OR CORRODED, OR IF THE PROPELLER IS REMOVED FOR OVERHAUL.

- (4) Remove the propeller mounting bolts and washers.

NOTE: When the propeller is removed between overhaul intervals, mounting bolts and washers may be reused if they are not damaged or corroded.

CAUTION: USE ADEQUATE PRECAUTIONS TO PROTECT THE PROPELLER ASSEMBLY FROM DAMAGE WHEN IT IS REMOVED FROM THE AIRCRAFT ENGINE AND WHEN IT IS STORED.

- (5) Using the support sling, lift the propeller from the mounting flange.
- (6) Remove and discard the engine shaft O-ring.
- (7) Put the propeller and associated parts on a suitable cart for transportation.

- C. Removing the K Flange Propeller Models HC-92()K-1D and HC-92()K-8()
Refer to Figure 3-4.

NOTE: If the propeller is equipped with an anti-ice or a de-ice system, follow the manufacturer's instructions for removing the components necessary for propeller removal.

CAUTION 1: INSTRUCTIONS AND PROCEDURES IN THIS SECTION MAY INVOLVE PROPELLER CRITICAL PARTS. REFER TO THE INTRODUCTION CHAPTER OF THIS MANUAL FOR INFORMATION ABOUT PROPELLER CRITICAL PARTS.

CAUTION 2: TO PREVENT DAMAGE TO THE BLADE AND BLADE PAINT, WRAP THE BLADE SHANKS IN SEVERAL LAYERS OF MASKING OR DUCT TAPE BEFORE REMOVING THE SPINNER DOME.

- (1) Spinner dome removal
- (a) Remove the screws and washers that secure the spinner dome to the spinner bulkhead.
 - (b) Remove the spinner dome.

WARNING 1: DURING ENGINE INSTALLATION OR REMOVAL, USING THE PROPELLER TO SUPPORT THE WEIGHT OF THE ENGINE IS NOT AUTHORIZED. UNAPPROVED INSTALLATION AND REMOVAL TECHNIQUES MAY CAUSE DAMAGE TO THE PROPELLER THAT MAY LEAD TO FAILURE AND RESULT IN AN AIRCRAFT ACCIDENT.

WARNING 2: DURING PROPELLER REMOVAL, AIRFRAME MANUFACTURER'S MANUALS AND PROCEDURES MUST BE FOLLOWED BECAUSE THEY MAY CONTAIN ISSUES VITAL TO AIRCRAFT SAFETY THAT ARE NOT CONTAINED IN THIS MANUAL OR IN THE HARTZELL PROPELLER INC. PROPELLER OVERHAUL MANUALS.

(2) Cut and remove the safety wire on the propeller mounting bolts.

WARNING: MAKE SURE THE SLING IS RATED UP TO 800 POUNDS (363 KG.) TO SUPPORT THE WEIGHT OF THE PROPELLER ASSEMBLY DURING REMOVAL.

(3) Support the propeller assembly with a sling.

NOTE 1: Supporting the propeller with the sling may be delayed until all but two mounting bolts and washers have been removed to permit propeller rotation for ease of nut removal.

NOTE 2: If the propeller will be reinstalled, and it has been dynamically balanced, make an identifying mark on the propeller hub and a matching mark on the engine flange to make sure of proper orientation during re-installation to prevent dynamic imbalance.

CAUTION: DISCARD THE PROPELLER MOUNTING BOLTS IF THEY ARE DAMAGED OR CORRODED, OR IF THE PROPELLER IS REMOVED FOR OVERHAUL.

(4) Remove the propeller mounting bolts and washers.

NOTE: When the propeller is removed between overhaul intervals, mounting bolts and washers may be reused if they are not damaged or corroded.

CAUTION: USE ADEQUATE PRECAUTIONS TO PROTECT THE PROPELLER ASSEMBLY FROM DAMAGE WHEN IT IS REMOVED FROM THE AIRCRAFT ENGINE AND WHEN IT IS STORED.

(5) Using the support sling, lift the propeller from the mounting flange.

(6) Remove and discard the engine shaft O-ring.

(7) Remove the shim.

(8) Remove the fasteners that attach the spinner adaptor ring to the engine starter gear.

(9) Remove the spinner adapter ring from the engine starter gear.

(10) Put the propeller and associated parts on a suitable cart for transportation.

- D. Removing the F Flange Propeller Models HC-92ZF-2() and HC-93ZF-2()
Refer to Figures 3-7 and 3-8.

NOTE: If the propeller is equipped with an anti-ice or a de-ice system, follow the manufacturer's instructions for removing the components necessary for propeller removal.

CAUTION 1: INSTRUCTIONS AND PROCEDURES IN THIS SECTION MAY INVOLVE PROPELLER CRITICAL PARTS. REFER TO THE INTRODUCTION CHAPTER OF THIS MANUAL FOR INFORMATION ABOUT PROPELLER CRITICAL PARTS.

CAUTION 2: TO PREVENT DAMAGE TO THE BLADE AND BLADE PAINT, WRAP THE BLADE SHANKS IN SEVERAL LAYERS OF MASKING OR DUCT TAPE BEFORE REMOVING THE SPINNER DOME.

- (1) Spinner dome removal
- (a) Remove the screws and washers that secure the spinner dome to the spinner bulkhead.
 - (b) Remove the spinner dome.

WARNING 1: DURING ENGINE INSTALLATION OR REMOVAL, USING THE PROPELLER TO SUPPORT THE WEIGHT OF THE ENGINE IS NOT AUTHORIZED. UNAPPROVED INSTALLATION AND REMOVAL TECHNIQUES MAY CAUSE DAMAGE TO THE PROPELLER THAT MAY LEAD TO FAILURE AND RESULT IN AN AIRCRAFT ACCIDENT.

WARNING 2: DURING PROPELLER REMOVAL, AIRFRAME MANUFACTURER'S MANUALS AND PROCEDURES MUST BE FOLLOWED BECAUSE THEY MAY CONTAIN ISSUES VITAL TO AIRCRAFT SAFETY THAT ARE NOT CONTAINED IN THIS MANUAL OR IN THE HARTZELL PROPELLER INC. PROPELLER OVERHAUL MANUALS.

WARNING 3: FOR SAFETY REASONS, THE PROPELLER MUST BE PUT IN THE FEATHER POSITION BEFORE IT IS REMOVED FROM THE AIRCRAFT.

- (2) Routine propeller engine shutdown will engage the start locks, preventing the propeller from feathering. For purposes of propeller removal, the propeller should be put in feather position during engine shutdown. If this was not accomplished, then the propeller may be feathered as follows:

CAUTION: DO NOT PUT THE BLADE PADDLE IN THE AREA OF THE DE-ICE BOOT WHEN APPLYING TORQUE TO A BLADE ASSEMBLY. PUT THE BLADE PADDLE IN THE THICKEST AREA OF THE BLADE, JUST OUTBOARD OF THE DE-ICE BOOT. USE ONE BLADE PADDLE PER BLADE.

- (a) Rotate the blades simultaneously to a slightly lower pitch to disengage the stop plates from the start locks.

- (b) Retract the start lock pins and hold them in place with a heavy wire inserted through the hole of each start lock housing.
 - (c) Slowly and carefully permit the blades to rotate to high/feather pitch.
- (3) Cut and remove the safety wire on the propeller mounting bolts.

WARNING: MAKE SURE THE SLING IS RATED UP TO 800 POUNDS (363 KG.) TO SUPPORT THE WEIGHT OF THE PROPELLER ASSEMBLY DURING REMOVAL.

- (4) Support the propeller assembly with a sling.

NOTE 1: Supporting the propeller with the sling may be delayed until all but two mounting bolts and washers have been removed to permit propeller rotation for ease of nut removal.

NOTE 2: If the propeller will be reinstalled, and it has been dynamically balanced, make an identifying mark on the propeller hub and a matching mark on the engine flange to make sure of proper orientation during re-installation to prevent dynamic imbalance.

CAUTION: DISCARD THE PROPELLER MOUNTING BOLTS IF THEY ARE DAMAGED OR CORRODED, OR IF THE PROPELLER IS REMOVED FOR OVERHAUL.

- (5) Remove the propeller mounting bolts and washers.

NOTE: When the propeller is removed between overhaul intervals, mounting bolts and washers may be reused if they are not damaged or corroded.

CAUTION: USE ADEQUATE PRECAUTIONS TO PROTECT THE PROPELLER ASSEMBLY FROM DAMAGE WHEN IT IS REMOVED FROM THE AIRCRAFT ENGINE AND WHEN IT IS STORED.

- (6) Using the support sling, lift the propeller from the mounting flange.

- (7) Remove and discard the engine shaft O-ring.
 - (8) Remove the spinner bulkhead, with the start locks attached.
 - (9) Put the propeller and associated parts on a suitable cart for transportation.
- E. Removing the K Flange Propeller Models HC-92()K-2()
Refer to Figure 3-7.

NOTE: If the propeller is equipped with an anti-ice or a de-ice system, follow the manufacturer's instructions for removing the components necessary for propeller removal.

CAUTION 1: INSTRUCTIONS AND PROCEDURES IN THIS SECTION MAY INVOLVE PROPELLER CRITICAL PARTS. REFER TO THE INTRODUCTION CHAPTER OF THIS MANUAL FOR INFORMATION ABOUT PROPELLER CRITICAL PARTS.

CAUTION 2: TO PREVENT DAMAGE TO THE BLADE AND BLADE PAINT, WRAP THE BLADE SHANKS IN SEVERAL LAYERS OF MASKING OR DUCT TAPE BEFORE REMOVING THE SPINNER DOME.

- (1) Spinner dome removal
 - (a) Remove the screws and washers that secure the spinner dome to the spinner bulkhead.
 - (b) Remove the spinner dome.

WARNING 1: DURING ENGINE INSTALLATION OR REMOVAL, USING THE PROPELLER TO SUPPORT THE WEIGHT OF THE ENGINE IS NOT AUTHORIZED. UNAPPROVED INSTALLATION AND REMOVAL TECHNIQUES MAY CAUSE DAMAGE TO THE PROPELLER THAT MAY LEAD TO FAILURE AND RESULT IN AN AIRCRAFT ACCIDENT.

WARNING 2: DURING PROPELLER REMOVAL, AIRFRAME MANUFACTURER'S MANUALS AND PROCEDURES MUST BE FOLLOWED BECAUSE THEY MAY CONTAIN ISSUES VITAL TO AIRCRAFT SAFETY THAT ARE NOT CONTAINED IN THIS MANUAL OR IN THE HARTZELL PROPELLER INC. PROPELLER OVERHAUL MANUALS.

WARNING 3: FOR SAFETY REASONS, THE PROPELLER MUST BE PUT IN THE FEATHER POSITION BEFORE IT IS REMOVED FROM THE AIRCRAFT.

- (2) Routine propeller engine shutdown will engage the start locks, preventing the propeller from feathering. For purposes of propeller removal, the propeller should be put in feather position during engine shutdown. If this was not accomplished, then the propeller may be feathered as follows:

CAUTION: DO NOT PUT THE BLADE PADDLE IN THE AREA OF THE DE-ICE BOOT WHEN APPLYING TORQUE TO A BLADE ASSEMBLY. PUT THE BLADE PADDLE IN THE THICKEST AREA OF THE BLADE, JUST OUTBOARD OF THE DE-ICE BOOT. USE ONE BLADE PADDLE PER BLADE.

- (a) Rotate the blades simultaneously to a slightly lower pitch to disengage the stop plates from the start locks.
 - (b) Retract the start lock pins and hold them in place with a heavy wire inserted through the hole of each start lock housing.
 - (c) Slowly and carefully permit the blades to rotate to high/feather pitch.
- (3) Cut and remove the safety wire on the propeller mounting bolts.

WARNING: MAKE SURE THE SLING IS RATED UP TO 800 POUNDS (363 KG.) TO SUPPORT THE WEIGHT OF THE PROPELLER ASSEMBLY DURING REMOVAL.

- (4) Support the propeller assembly with a sling.

NOTE 1: Supporting the propeller with the sling may be delayed until all but two mounting bolts and washers have been removed to permit propeller rotation for ease of nut removal.

NOTE 2: If the propeller will be reinstalled, and it has been dynamically balanced, make an identifying mark on the propeller hub and a matching mark on the engine flange to make sure of proper orientation during re-installation to prevent dynamic imbalance.

- (5) Remove the start lock brackets to access the mounting bolts.

NOTE: It is not necessary to remove the wire that is holding the start lock pin in place.

CAUTION: DISCARD THE PROPELLER MOUNTING BOLTS IF THEY ARE DAMAGED OR CORRODED, OR IF THE PROPELLER IS REMOVED FOR OVERHAUL.

(6) Remove the propeller mounting bolts and washers.

NOTE: For propeller removals between overhaul intervals, mounting bolts and washers may be reused if they are not damaged or corroded.

CAUTION: USE ADEQUATE PRECAUTIONS TO PROTECT THE PROPELLER ASSEMBLY FROM DAMAGE WHEN IT IS REMOVED FROM THE AIRCRAFT ENGINE AND WHEN IT IS STORED.

(7) Using the support sling, lift the propeller from the mounting flange.

(8) Remove and discard the shaft O-ring.

(9) Remove the shim.

(10) Remove the fasteners that attach the spinner adapter ring to the engine starter gear.

(11) Remove the spinner adapter ring from the engine starter gear.

(12) Remove the spinner bulkhead.

(13) Put the propeller and associated parts on a suitable cart for transportation.

- F. Removing the F Flange Propeller Models (B)HC-92()F-3
Refer to Figure 3-10.

NOTE: If the propeller is equipped with an anti-ice or a de-ice system, follow the manufacturer's instructions for removing the components necessary for propeller removal.

CAUTION 1: INSTRUCTIONS AND PROCEDURES IN THIS SECTION MAY INVOLVE PROPELLER CRITICAL PARTS. REFER TO THE INTRODUCTION CHAPTER OF THIS MANUAL FOR INFORMATION ABOUT PROPELLER CRITICAL PARTS.

CAUTION 2: TO PREVENT DAMAGE TO THE BLADE AND BLADE PAINT, WRAP THE BLADE SHANKS IN SEVERAL LAYERS OF MASKING OR DUCT TAPE BEFORE REMOVING THE SPINNER DOME.

- (1) Spinner dome removal
 - (a) Remove the screws and washers that secure the spinner dome to the spinner bulkhead.
 - (b) Remove the spinner dome.
- (2) Disconnect the propeller beta ring from the carbon block assembly and lever. Refer to Figure 3-16.
 - (a) Disconnect the outer end of the lever from the control push-pull fitting.
 - (b) Disconnect the lever from the beta valve spool.
 - (c) Remove the carbon block assembly and lever from the beta ring.

NOTE: Replace the carbon block unit at overhaul, or if the side clearance between the beta ring and carbon block exceeds 0.010 inch (0.25 mm).

- (d) If the propeller is equipped with an anti-ice or a de-ice system, follow the manufacturer's instructions for removing the components necessary for propeller removal.

WARNING 1: DURING ENGINE INSTALLATION OR REMOVAL, USING THE PROPELLER TO SUPPORT THE WEIGHT OF THE ENGINE IS NOT AUTHORIZED. UNAPPROVED INSTALLATION AND REMOVAL TECHNIQUES MAY CAUSE DAMAGE TO THE PROPELLER THAT MAY LEAD TO FAILURE AND RESULT IN AN AIRCRAFT ACCIDENT.

WARNING 2: DURING PROPELLER REMOVAL, AIRFRAME MANUFACTURER'S MANUALS AND PROCEDURES MUST BE FOLLOWED BECAUSE THEY MAY CONTAIN ISSUES VITAL TO AIRCRAFT SAFETY THAT ARE NOT CONTAINED IN THIS MANUAL OR THE HARTZELL PROPELLER INC. PROPELLER OVERHAUL MANUAL.

(3) Cut and remove the safety wire on the propeller mounting bolts.

WARNING: MAKE SURE THE SLING IS RATED UP TO 800 POUNDS (363 KG.) TO SUPPORT THE WEIGHT OF THE PROPELLER ASSEMBLY DURING REMOVAL.

(4) Support the propeller assembly with a sling.

NOTE 1: Supporting the propeller with the sling may be delayed until all but two mounting bolts and washers have been removed to permit propeller rotation for ease of nut removal.

NOTE 2: If the propeller will be reinstalled, and it has been dynamically balanced, make an identifying mark on the propeller hub and a matching mark on the engine flange to make sure of proper orientation during re-installation to prevent dynamic imbalance.

(5) Cut and remove the safety wire on the propeller mounting bolts or mounting nuts.

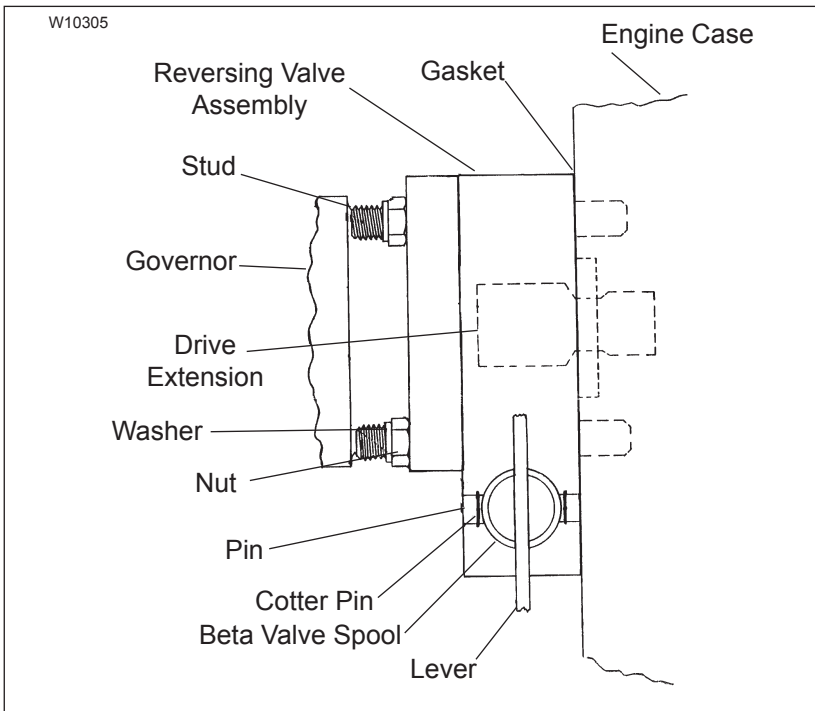

Reversing (Beta) System and Governing Hardware
Figure 3-31

CAUTION: DISCARD THE PROPELLER MOUNTING BOLTS IF THEY ARE DAMAGED OR CORRODED, WHEN THE PROPELLER IS REMOVED FOR OVERHAUL.

(6) Remove the propeller mounting bolts and washers.

NOTE 1: On propeller model HC-92WF-3 when installed on a TSIO-520-C engine, remove the mounting nuts and washers from the mounting studs.

NOTE 2: When the propeller is removed between overhaul intervals, mounting bolts and washers may be reused if they are not damaged or corroded.

CAUTION: USE ADEQUATE PRECAUTIONS TO PROTECT THE PROPELLER ASSEMBLY FROM DAMAGE WHEN IT IS REMOVED FROM THE AIRCRAFT ENGINE AND WHEN IT IS STORED.

(7) Using the support sling, lift the propeller from the mounting flange.

(8) Remove and discard the engine flange O-ring.

(9) On propeller model HC-92WF-3 when installed on a TSIO-520-C engine only, remove the spacer from the engine flange.

(10) Remove and discard the propeller flange O-ring.

(11) Decompress and remove the beta system puller.

(12) Put the propeller and associated parts on a suitable cart for transportation.

(13) Reversing (beta) system and governing hardware removal. Refer to Figure 3-31 and Table 3-1.

NOTE: The lever was previously disconnected from the cockpit control and beta valve spool. The lever and carbon block assembly were previously removed from the beta ring to permit propeller removal.

(a) Disconnect the governor RPM control cable from the cockpit.

- (b) Remove the nuts that secure the governor and beta valve to the engine.
- (c) Remove the drive extension between the engine drive and the governor.
- (d) Remove the governor gasket from between the valve face and the governor.
- (e) Remove the beta valve unit.
- (f) Remove the governor gasket from between the engine pad and governor.
- (g) Remove the snap ring that retains the carbon block assembly to the lever. Refer to Figure 3-15.

G. Removing the F Flange Propeller Models

BHC-92(W,Z)F-3(L)G

Refer to Figure 3-17.

NOTE: If the propeller is equipped with an anti-ice or a de-ice system, follow the manufacturer's instructions for removing the components necessary for propeller removal.

CAUTION 1: INSTRUCTIONS AND PROCEDURES IN THIS SECTION MAY INVOLVE PROPELLER CRITICAL PARTS. REFER TO THE INTRODUCTION CHAPTER OF THIS MANUAL FOR INFORMATION ABOUT PROPELLER CRITICAL PARTS.

CAUTION 2: TO PREVENT DAMAGE TO THE BLADE AND BLADE PAINT, WRAP THE BLADE SHANKS IN SEVERAL LAYERS OF MASKING OR DUCT TAPE BEFORE REMOVING THE SPINNER DOME.

- (1) Disconnect the propeller beta ring from the carbon block assembly and lever.
 - (a) Disconnect the outer end of the lever from the control push-pull fitting.
 - (b) Disconnect the lever from the beta valve spool.

- (c) Remove the carbon block assembly and lever from the beta ring.

NOTE: Replace the carbon block unit at overhaul, or if the side clearance between the beta ring and carbon block exceeds 0.010 inch (0.25 mm).

WARNING 1: DURING ENGINE INSTALLATION OR REMOVAL, USING THE PROPELLER TO SUPPORT THE WEIGHT OF THE ENGINE IS NOT AUTHORIZED. UNAPPROVED INSTALLATION AND REMOVAL TECHNIQUES MAY CAUSE DAMAGE TO THE PROPELLER THAT MAY LEAD TO FAILURE AND RESULT IN AN AIRCRAFT ACCIDENT.

WARNING 2: DURING PROPELLER REMOVAL, AIRFRAME MANUFACTURER'S MANUALS AND PROCEDURES MUST BE FOLLOWED BECAUSE THEY MAY CONTAIN ISSUES VITAL TO AIRCRAFT SAFETY THAT ARE NOT CONTAINED IN THIS MANUAL OR IN THE HARTZELL PROPELLER INC. PROPELLER OVERHAUL MANUAL.

- (2) Cut and remove the safety wire on the propeller mounting bolts.
- (3) Use a beta system puller CST-2987 to compress the beta system spring and pull the beta ring forward to expose the propeller mounting nuts.

WARNING: MAKE SURE THE SLING IS RATED UP TO 800 POUNDS (363 KG.) TO SUPPORT THE WEIGHT OF THE PROPELLER ASSEMBLY DURING REMOVAL.

(4) Support the propeller assembly with a sling.

NOTE 1: Supporting the propeller with the sling may be delayed until all but two mounting bolts and washers have been removed to allow rotating the propeller for ease of nut removal.

NOTE 2: If the propeller will be reinstalled, and it has been dynamically balanced, make an identifying mark on the propeller hub and a matching mark on the engine flange to ensure proper orientation during re-installation to prevent dynamic imbalance.

CAUTION: DISCARD THE PROPELLER MOUNTING STUDS IF THEY ARE DAMAGED OR CORRODED, WHEN THE PROPELLER IS REMOVED FOR OVERHAUL.

(5) Remove the propeller mounting nuts and washers.

NOTE: For propeller removals between overhaul intervals, mounting studs and washers may be reused if they are not damaged or corroded.

CAUTION: USE ADEQUATE PRECAUTIONS TO PROTECT THE PROPELLER ASSEMBLY FROM DAMAGE WHEN IT IS REMOVED FROM THE AIRCRAFT ENGINE AND WHEN IT IS STORED.

(6) Using the support sling, lift the propeller from the mounting flange.

(7) Remove and discard the engine flange O-ring.

(8) Remove the adapter pulley with attached fan assembly from the propeller mounting studs.

(9) Remove and discard the propeller flange O-ring.

(10) Decompress and remove the beta system puller.

(11) Put the propeller and associated parts on a suitable cart for transportation.

(12) Reversing (beta) system and governing hardware removal. Refer to Figure 3-31 and Table 3-1.

NOTE: The lever was previously disconnected from the cockpit control and beta valve spool. The lever and carbon block assembly were previously removed from the beta ring to permit propeller removal.

- (a) Disconnect the governor RPM control cable from the cockpit.
- (b) Remove the nuts that secure the governor and beta valve to the engine.
- (c) Remove the drive extension between the engine drive and the governor.
- (d) Remove the governor gasket from between the valve face and the governor.
- (e) Remove the beta valve unit.
- (f) Remove the governor gasket from between the engine pad and governor.
- (g) Remove the snap ring that retains the carbon block assembly to the lever. Refer to Figure 3-15.

- H. Removing the F Flange Propeller Model HC-92WF-5A
Refer to Figure 3-19.

WARNING: FOR SAFETY REASONS, THE PROPELLER MUST BE PUT IN THE FEATHER POSITION BEFORE IT IS REMOVED FROM THE AIRCRAFT.

- (1) Routine propeller engine shutdown will engage the start locks, preventing the propeller from feathering. For purposes of propeller removal, the propeller should be put in feather position during engine shutdown. If this was not accomplished, then the propeller may be feathered as follows:

CAUTION 1: INSTRUCTIONS AND PROCEDURES IN THIS SECTION MAY INVOLVE PROPELLER CRITICAL PARTS. REFER TO THE INTRODUCTION CHAPTER OF THIS MANUAL FOR INFORMATION ABOUT PROPELLER CRITICAL PARTS.

CAUTION 2: DO NOT PUT THE BLADE PADDLE IN THE AREA OF THE DE-ICE BOOT WHEN APPLYING TORQUE TO A BLADE ASSEMBLY. PUT THE BLADE PADDLE IN THE THICKEST AREA OF THE BLADE, JUST OUTBOARD OF THE DE-ICE BOOT. USE ONE BLADE PADDLE PER BLADE.

- (a) Rotate the blades simultaneously to a slightly lower pitch to disengage the stop plates from the start locks.
- (b) Retract the start lock pins and hold them in place with a heavy wire inserted through the hole of each start lock housing.
- (c) Slowly and carefully permit the blades to rotate to high/feather pitch.

NOTE: If the propeller is equipped with an anti-ice or a de-ice system, follow the manufacturer's instructions for removing the components necessary for propeller removal.

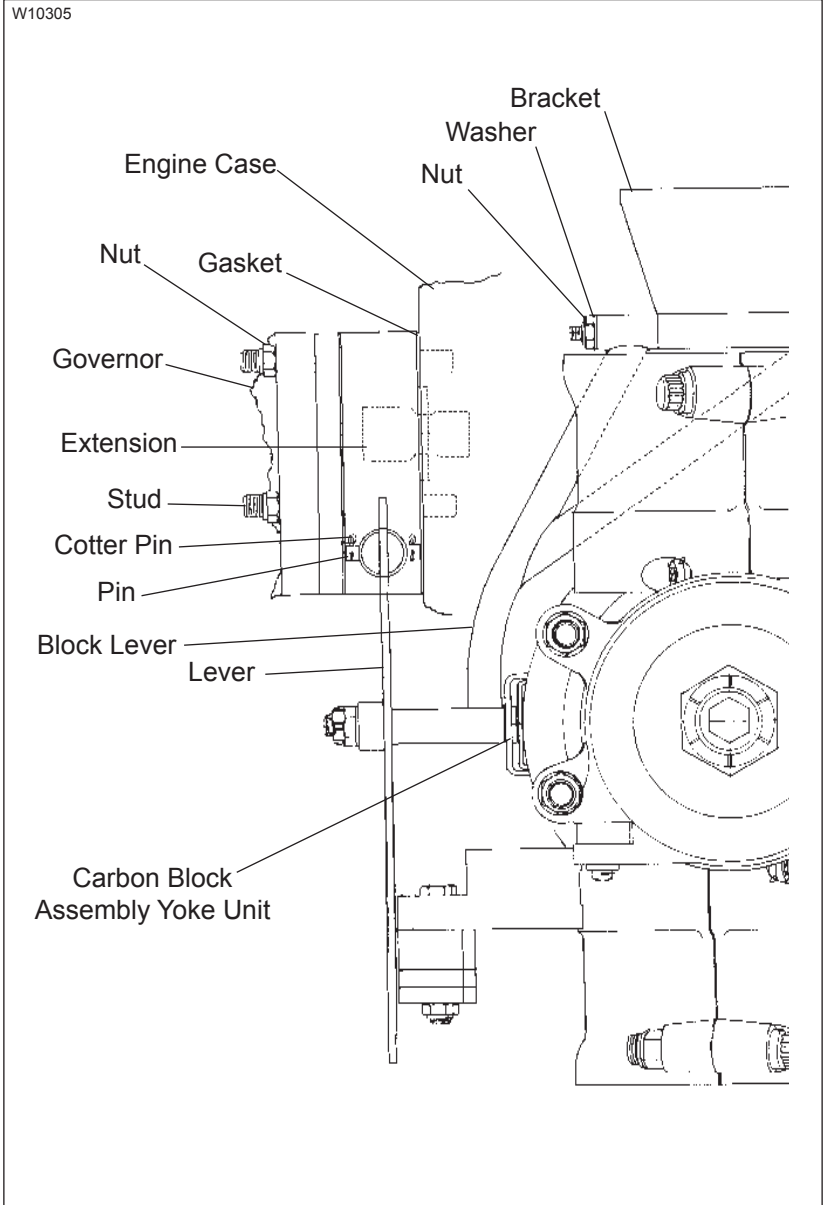

Disconnecting the Beta Ring
Figure 3-32

CAUTION: TO PREVENT DAMAGE TO THE BLADE AND BLADE PAINT, WRAP THE BLADE SHANKS IN SEVERAL LAYERS OF MASKING OR DUCT TAPE BEFORE REMOVING THE SPINNER DOME.

- (2) Spinner dome removal
 - (a) Remove the screws and washers that secure the spinner to the spinner bulkhead.
 - (b) Remove the spinner dome.
- (3) Disconnect the propeller beta ring from the carbon block assembly and lever. Refer to Figure 3-32.
 - (a) Disconnect the outer end of the lever from the control push-pull fitting.
 - (b) Disconnect the lever from the beta valve spool and block assembly.
 - (c) Remove the lever.
 - (d) Remove the bolt, nut, and washer that connect the block lever to the bracket that is attached to the engine.
 - (e) Remove the block lever and carbon block assembly from the beta ring.
 - (f) Slide the carbon block assembly out of the block lever.
- (4) Remove the safety wire from the beta linkage.
- (5) Remove the beta linkage.
- (6) Remove the carbon block assembly from the beta ring.

WARNING 1: DURING ENGINE INSTALLATION OR REMOVAL, USING THE PROPELLER TO SUPPORT THE WEIGHT OF THE ENGINE IS NOT AUTHORIZED. UNAPPROVED INSTALLATION AND REMOVAL TECHNIQUES MAY CAUSE DAMAGE TO THE PROPELLER THAT MAY LEAD TO FAILURE AND RESULT IN AN AIRCRAFT ACCIDENT.

WARNING 2: DURING PROPELLER REMOVAL, AIRFRAME MANUFACTURER'S MANUALS AND PROCEDURES MUST BE FOLLOWED BECAUSE THEY MAY CONTAIN ISSUES VITAL TO AIRCRAFT SAFETY THAT ARE NOT CONTAINED IN THIS MANUAL OR THE HARTZELL PROPELLER INC. PROPELLER OVERHAUL MANUAL.

- (7) Cut and remove the safety wire on the propeller mounting bolts.
- (8) Use a beta system puller CST-2987 to compress the beta system spring and pull the beta ring forward to expose the propeller mounting bolts and washers.

WARNING: MAKE SURE THE SLING IS RATED UP TO 800 POUNDS (363 KG.) TO SUPPORT THE WEIGHT OF THE PROPELLER ASSEMBLY DURING REMOVAL.

- (9) Support the propeller assembly with a sling.

NOTE 1: Supporting the propeller with the sling may be delayed until all but two mounting bolts and washers have been removed to permit propeller rotation for ease of nut removal.

NOTE 2: If the propeller will be reinstalled, and it has been dynamically balanced, make an identifying mark on the propeller hub and a matching mark on the engine flange to make sure of proper orientation during re-installation to prevent dynamic imbalance.

CAUTION: DISCARD THE PROPELLER MOUNTING BOLTS IF THEY ARE DAMAGED OR CORRODED, WHEN THE PROPELLER IS REMOVED FOR OVERHAUL.

(10) Remove the propeller mounting bolts and washers.

NOTE: When the propeller is removed between overhaul intervals, mounting bolts and washers may be reused if they are not damaged or corroded.

CAUTION: USE ADEQUATE PRECAUTIONS TO PROTECT THE PROPELLER ASSEMBLY FROM DAMAGE WHEN IT IS REMOVED FROM THE AIRCRAFT ENGINE AND WHEN IT IS STORED.

(11) Using the support sling, lift the propeller from the mounting flange.

(12) Remove and discard the engine flange O-ring.

(13) Decompress and remove the beta system puller.

(14) Put the propeller and associated parts on a suitable cart for transportation.

(15) Reversing (beta) system and governing hardware removal. Refer to Figure 3-32 and Table 3-1.

NOTE: The lever was previously disconnected from the cockpit control and beta valve spool. The lever and carbon block assembly were previously removed from the beta ring to permit propeller removal.

- (a) Disconnect the governor RPM control cable from the cockpit.
- (b) Remove the nuts that secure the governor and beta valve to the engine.
- (c) Remove the drive extension between the engine drive and the governor.
- (d) Remove the governor gasket from between the valve face and the governor.
- (e) Remove the beta valve unit.

- (f) Remove the governor gasket from between the engine pad and governor.
- (g) Remove the snap ring that retains the carbon block assembly to the lever. Refer to Figure 3-15.

I. Removing the 20 Spline Propeller Models HC-93Z20-1()
Refer to Figure 3-21.

NOTE: If the propeller is equipped with an anti-ice or a de-ice system, follow the manufacturer's instructions for removing the components necessary for propeller removal.

CAUTION 1: INSTRUCTIONS AND PROCEDURES IN THIS SECTION MAY INVOLVE PROPELLER CRITICAL PARTS. REFER TO THE INTRODUCTION CHAPTER OF THIS MANUAL FOR INFORMATION ABOUT PROPELLER CRITICAL PARTS.

CAUTION 2: TO PREVENT DAMAGE TO THE BLADE AND BLADE PAINT, WRAP THE BLADE SHANKS IN SEVERAL LAYERS OF MASKING OR DUCT TAPE BEFORE REMOVING THE SPINNER DOME.

- (1) Spinner dome removal
 - (a) Remove the screws and washers that secure the spinner dome to the spinner bulkhead.
 - (b) Remove the spinner dome.

WARNING 1: DURING ENGINE INSTALLATION OR REMOVAL, USING THE PROPELLER TO SUPPORT THE WEIGHT OF THE ENGINE IS NOT AUTHORIZED. UNAPPROVED INSTALLATION AND REMOVAL TECHNIQUES MAY CAUSE DAMAGE TO THE PROPELLER THAT MAY LEAD TO FAILURE AND RESULT IN AN AIRCRAFT ACCIDENT.

WARNING 2: DURING PROPELLER REMOVAL, AIRFRAME MANUFACTURER'S MANUALS AND PROCEDURES MUST BE FOLLOWED BECAUSE THEY MAY CONTAIN ISSUES VITAL TO AIRCRAFT SAFETY THAT ARE NOT CONTAINED IN THIS MANUAL OR IN THE HARTZELL PROPELLER INC. PROPELLER OVERHAUL MANUALS.

CAUTION 1: OIL WILL FLOW OUT OF THE PROPELLER WHEN THE PISTON IS REMOVED. PUT A DRIP PAN UNDER THE PROPELLER TO CATCH THE EXCESS OIL.

CAUTION 2: USING A FELT-TIPPED PEN, IDENTIFY EACH PISTON ROD AND ITS COMPONENTS WITH A CORRESPONDING LETTER. THIS WILL INSURE THAT THE COMPONENTS ARE REASSEMBLED ON THE PISTON ROD FROM WHICH THEY WERE REMOVED.

- (2) Piston Removal - Refer to Figure 3-21
- (a) Remove the self-locking nut from each piston rod.
 - (b) Loosen the set screw in each fork.
 - (c) Remove the washer from each piston rod.
 - (d) Slide the piston away from the hub and to the low pitch position, until the piston rods clear the bulkhead and forks.
 - (e) Remove the pitch change block from each clamp linkscrew.

- (f) The piston ears and guide collar should have corresponding index numbers (1, 2, and 3) impression stamped or marked with a felt-tipped pen. If they are not marked, number them with a felt-tipped pen.

NOTE: This will insure that the components are reassembled in their original location.

- (g) Slide the piston off the cylinder.
 - (h) To prevent the loss of the sleeve, fork, and high pitch stop spacers, reinstall the self-locking nut on each piston rod.
- (3) Remove the hub lock safety pin. Refer to Figure 3-30.
 - (4) Completely loosen the hub nut from the engine shaft threads.

NOTE 1: If the propeller will be reinstalled, and it has been dynamically balanced, make an identifying mark on the propeller hub and a matching mark on the engine flange to make sure of proper orientation during re-installation to prevent dynamic imbalance.

NOTE 2: Because the shaft nut is pulling the propeller hub off the tapered rear cone, there will be significant resistance to the loosening of the shaft nut.

WARNING: MAKE SURE THE SLING IS RATED UP TO 800 POUNDS (363 KG.) TO SUPPORT THE WEIGHT OF THE PROPELLER ASSEMBLY DURING REMOVAL.

CAUTION: USE ADEQUATE PRECAUTIONS TO PROTECT THE PROPELLER ASSEMBLY FROM DAMAGE WHEN IT IS REMOVED FROM THE AIRCRAFT ENGINE AND WHEN IT IS STORED.

- (5) Using the support sling, slide the propeller from the engine splined shaft and lift the propeller from the engine.
- (6) Remove and discard the rear cone O-ring.

- (7) Put the propeller and associated parts on a suitable cart for transportation.
- J. Removing the 20 Spline HC-93Z20-2() and the 30 Spline HC-93Z30-2() Propeller Models
Refer to Figures 3-23 through 3-25.

NOTE: If the propeller is equipped with an anti-ice or a de-ice system, follow the manufacturer's instructions for removing the components necessary for propeller removal.

CAUTION 1: INSTRUCTIONS AND PROCEDURES IN THIS SECTION MAY INVOLVE PROPELLER CRITICAL PARTS. REFER TO THE INTRODUCTION CHAPTER OF THIS MANUAL FOR INFORMATION ABOUT PROPELLER CRITICAL PARTS.

CAUTION 2: TO PREVENT DAMAGE TO THE BLADE AND BLADE PAINT, WRAP THE BLADE SHANKS IN SEVERAL LAYERS OF MASKING OR DUCT TAPE BEFORE REMOVING THE SPINNER DOME.

- (1) Spinner dome removal
- (a) Remove the screws and washers that secure the spinner dome to the spinner bulkhead.
 - (b) Remove the spinner dome.

WARNING 1: DURING ENGINE INSTALLATION OR REMOVAL, USING THE PROPELLER TO SUPPORT THE WEIGHT OF THE ENGINE IS NOT AUTHORIZED. UNAPPROVED INSTALLATION AND REMOVAL TECHNIQUES MAY CAUSE DAMAGE TO THE PROPELLER THAT MAY LEAD TO FAILURE AND RESULT IN AN AIRCRAFT ACCIDENT.

WARNING 2: DURING PROPELLER REMOVAL, AIRFRAME MANUFACTURER'S MANUALS AND PROCEDURES MUST BE FOLLOWED BECAUSE THEY MAY CONTAIN ISSUES VITAL TO AIRCRAFT SAFETY THAT ARE NOT CONTAINED IN THIS MANUAL OR IN THE HARTZELL PROPELLER INC. PROPELLER OVERHAUL MANUALS.

WARNING 3: FOR SAFETY REASONS, THE PROPELLER MUST BE PUT IN THE FEATHER POSITION BEFORE IT IS REMOVED FROM THE AIRCRAFT.

- (2) Routine propeller engine shutdown will engage the start locks, preventing the propeller from feathering. For purposes of propeller removal, the propeller should be put in feather position during engine shutdown. If this was not accomplished, then the propeller may be feathered as follows:

CAUTION: DO NOT PUT THE PADDED BAR IN THE AREA OF THE DE-ICE BOOT WHEN APPLYING TORQUE TO A BLADE ASSEMBLY. PUT THE BAR IN THE THICKEST AREA OF THE BLADE, JUST OUTBOARD OF THE DE-ICE BOOT. USE ONE BLADE PADDLE PER BLADE.

- (a) Rotate the blades simultaneously to a slightly lower pitch to disengage the stop plates from the start locks.

- (b) Retract the start lock pins and hold them in put with a heavy wire inserted through the hole of each start lock housing.
 - (c) Slowly and carefully permit the blades to rotate to high/feather pitch.
- (3) Piston removal - Refer to Figures 3-23 through 3-25
- (a) Remove the piston nut.
 - (b) Remove the safety wire from the link pin units.
 - (c) Remove the safety screws from each link pin unit.
 - (d) Remove each link pin unit.
 - (e) The piston ears and guide collar should have corresponding index numbers (1, 2, and 3) impression stamped or marked with a felt-tipped pen. If they are not marked, number them with a felt-tipped pen.
- NOTE:** This will make sure that the components are reassembled in their original location.
- (f) Remove the socket head cap screw, jam nut, and washer from each piston guide rod.
 - (g) Slide the piston off the cylinder.
- (4) Spring assembly removal - Refer to Figure 3-28
- (a) Configuration A - Propeller model HC-93Z20-2C1
 - 1 Remove the safety wire from the ring retention plate screws.
 - 2 Remove the ring retention plate screws.
 - 3 Remove the ring retention plate.
 - 4 Remove the spring retainer.
 - 5 Remove the split retainer from the recess in the cylinder.
 - 6 Remove the spring assembly from the cylinder.
 - (b) Configuration B - Propeller model HC-93Z30-2E
 - 1 Remove the safety wire from the spring cup and cylinder. Refer to Figure 3-28.
 - 2 Using a spanner wrench BT-461 (Refer to Figure 3-28) or strap wrench 100923 unthread the spring retainer and feathering spring assembly from the cylinder.

- (9) Using the support sling, slide the propeller from the engine splined shaft and lift the propeller from the engine.
- (10) Remove and discard the rear cone O-ring on the engine splined shaft.
- (11) Remove the rear cone.
- (12) Remove the spinner bulkhead.
- (13) Put the propeller and associated parts on a suitable cart for transportation.

CONTENTS

1. Operational Tests.....	4-3
A. Initial Run-Up	4-3
B. Static RPM Check.....	4-4
C. Post-Run Check.....	4-4
2. Propeller Ice Protection Systems	4-4
A. Electric De-ice System.....	4-4
B. Anti-ice System.....	4-5
3. Troubleshooting	4-5
A. Incorrect Maximum RPM (on Ground).....	4-5
B. Hunting and Surging	4-6
C. Engine Speed Varies with Airspeed	4-7
D. Loss of Propeller Control - HC-92() ()-8() Propeller Models.....	4-9
E. Loss of Propeller Control - (B)HC-92()F-1(), HC-92()K-1(), HC-93Z20-1(), HC-92() ()-2(), HC-93() ()-2(), (B)HC-92()F-3(), and HC-92WF-5A Propeller Models.....	4-9
F. Failure to Feather or Feathers Slowly - HC-92() ()-2(), HC-93() ()-2(), and HC-92WF-5A Propeller Models.....	4-10
G. Failure to Unfeather - HC-92() ()-2(), HC-93() ()-2(), and HC-92WF-5A propeller models.....	4-10
H. Start Locks (Anti-Feather Latches) Fail to Engage on Shutdown - HC-9() ()-2() () and HC-92WF-5A Propellers	4-11
I. Vibration.....	4-12
J. Propeller Overspeed	4-13
K. Propeller Underspeed	4-13
L. Oil or Grease Leakage.....	4-14

(This page is intentionally blank.)

1. Operational Tests

Following propeller installation, and before flight, the propeller hydraulic system must be purged of air and proper operation verified.

CAUTION: INSTRUCTIONS AND PROCEDURES IN THIS SECTION MAY INVOLVE PROPELLER CRITICAL PARTS. REFER TO THE INTRODUCTION CHAPTER OF THIS MANUAL FOR INFORMATION ABOUT PROPELLER CRITICAL PARTS.

WARNING: REFER TO THE AIRCRAFT MAINTENANCE MANUAL FOR ADDITIONAL PROCEDURES THAT MAY BE REQUIRED AFTER PROPELLER INSTALLATION.

A. Initial Run-Up

- (1) Perform engine start and warm-up per the Pilot's Operating Handbook (POH).
- (2) Cycle the propeller control throughout its operating pitch range from low to high (or as directed by the POH).
- (3) Repeat this procedure at least three times to purge air from the propeller hydraulic system and to introduce warmed oil to the cylinder.

NOTE: Pitch change response on the first operation from low to high blade angle may be slow, but should speed up on the second and third cycles.

- (4) Verify proper operation from low pitch to high pitch and throughout operating range.
- (5) Shut down the engine in accordance with the POH.

NOTE: Air trapped in the propeller hydraulic system will cause the pitch control to be imprecise and may result in propeller surging.

B. Static RPM Check

NOTE: This operational check should be performed after installation, maintenance, or propeller adjustment.

CAUTION: A CALIBRATED TACHOMETER MUST BE USED TO MAKE SURE OF THE ACCURACY OF THE RPM CHECK.

- (1) Set the brakes and chock the aircraft or tie aircraft down.
- (2) Back the governor Maximum RPM Stop out one turn.
- (3) Start the engine.
- (4) Advance the propeller control lever to MAX (max RPM), then retard the control lever one inch (25.4 mm).
- (5) SLOWLY advance the throttle to maximum manifold pressure.
- (6) Slowly advance the propeller control lever until the engine speed stabilizes.
 - (a) If engine speed stabilizes at the maximum power static RPM specified by the TC or STC holder, then the low pitch stop is set correctly.
 - (b) If engine speed stabilizes above or below the rated RPM, the low pitch stop may require adjustment. Refer to the Testing and Troubleshooting chapter and perform the adjustments under Max. RPM (Static) Low Pitch Stop Adjustment.
- (7) Stop the engine.
- (8) Return the governor Maximum RPM Stop to the original position, or adjust the governor to the rated RPM with the Maximum RPM Stop screw.

C. Post-Run Check

After engine shutdown, check the propeller for signs of engine oil leakage.

2. Propeller Ice Protection Systems**A. Electric De-ice System**

- (1) Consult the Pilot Operating Handbook (including all supplements) regarding flight into conditions of known icing. The aircraft may not be certified for flight in known icing conditions, even though propeller de-ice equipment is installed.

- (2) Refer to the Anti-ice and De-ice Systems chapter of this manual for functional tests of the de-ice system.

B. Anti-ice System

- (1) Consult the Pilot Operating Handbook (including all supplements) regarding flight into conditions of known icing. The aircraft may not be certified for flight in known icing conditions, even though propeller anti-ice equipment is installed.
- (2) Refer to the Anti-ice and De-ice Systems chapter of this manual for functional tests of the anti-ice system.

3. Troubleshooting

CAUTION: INSTRUCTIONS AND PROCEDURES IN THIS SECTION MAY INVOLVE PROPELLER CRITICAL PARTS. REFER TO THE INTRODUCTION CHAPTER OF THIS MANUAL FOR INFORMATION ABOUT PROPELLER CRITICAL PARTS.

A. Incorrect Maximum RPM (on Ground)

- (1) Incorrect maximum RPM on the ground may be caused by low engine power, and incorrect governor maximum RPM stop setting, or an incorrect propeller low pitch stop.

CAUTION: A CALIBRATED TACHOMETER MUST BE USED TO MAKE SURE THE ACCURACY OF THE RPM CHECK.

- (2) Perform a check as described in the Maximum RPM Check (On Ground) procedure in the Maintenances Practices chapter of this manual.
- (3) Maximum RPM is Low
 - (a) Engine power is low
 - 1 Follow aircraft POH and/or AMM recommended checks to determine if the engine power is low.
 - 2 If the engine power is low, refer to a certificated engine repair station or the engine manufacturer.

- (b) If the engine power is within acceptable limits, examine the maximum RPM stop setting of the governor.
 - (4) Maximum RPM is High
 - (a) Engine power is high
 - 1 Follow the aircraft POH and/or AMM recommended engine checks to determine if the engine power is high.
 - 2 If the engine power is high, refer to an appropriately licensed engine repair station or to the engine manufacturer.
 - (b) If the engine power is within acceptable limits, examine the maximum RPM stop setting of the governor.
 - (5) Governor maximum RPM stop setting
 - (a) When RPM is high, both the governor maximum RPM stop and the propeller low pitch blade angle are improperly adjusted.
 - (b) Adjust the governor maximum RPM stop to obtain the rated maximum RPM.
 - (c) For low pitch setting verification refer to the procedures in the Maintenance Practices chapter of this manual.
- B. Hunting and Surging**
- Hunting is characterized by a cyclic variation in engine speed above and below desired speed. Surging is characterized by a large increase/decrease in engine speed, followed by a return to set speed after one or two occurrences.
- (1) If propeller is hunting, a certified propeller repair station with the appropriate rating should check:
 - (a) Governor
 - (b) Fuel control
 - (c) Synchrophaser, or synchronizer.
 - (2) If propeller is surging:
 - (a) Perform the steps 1.A.(1)-(5) under Operational Tests section in this chapter to release trapped air from the propeller. If surging reoccurs it is most likely due to a faulty governor.

- (b) Hunting and/or surging may also be caused by friction or binding within the governor control, or internal propeller corrosion, which causes the propeller to react slower to governor commands.
- 1 The governor must be tested on a test bench at a certified repair station with the appropriate rating to isolate these faults.
- (c) Hunting and/or surging on reversing propellers (propeller models [B]HC-92[]F-3[] and HC-92WF-5A) when operating at or near low pitch may be caused by excessive side clearance between the beta ring and the carbon block assembly. For side clearance limits, refer to Carbon Block Assemblies in the Maintenance Practices chapter of this manual.
- C. Engine Speed Varies with Airspeed
- (1) A constant speed propeller will experience some small variances in engine speed that are normal and are no cause for concern.
 - (2) Increase in engine speed while descending or increasing airspeed:
 - (a) HC-92()(-)8() propeller models:
 - 1 Governor is not increasing oil volume in the propeller.
 - 2 Engine oil transfer bearing is leaking excessively.
 - 3 Excessive friction in the blade bearings, in the pitch change mechanism, or in the misalignment between the guide collar and the piston rods.
 - (b) (B)HC-92()F-1(), HC-92()K-1(), HC-93Z20-1(), HC-92()(-)2(), HC-93()(-)2(), (B)HC-92()F-3(), and HC-92WF-5A propeller models:
 - 1 Governor is not reducing oil volume in the propeller.
 - 2 Excessive friction in the blade bearings or the pitch change mechanism.
 - 3 Excessive friction in the misalignment between the guide collar and the piston rods.

- (3) Decrease in engine speed while increasing airspeed:
- (a) HC-92()(-8()) propeller models:
 - 1 Governor pilot valve is stuck and is excessively increasing oil volume.
 - (b) (B)HC-92()F-1(), HC-92()K-1(), HC-93Z20-1(), HC-92()(-2()), HC-93()(-2()), (B)HC-92()F-3(), and HC-92WF-5A propeller models:
 - 1 Governor pilot valve is stuck and is excessively decreasing oil volume.
 - 2 Feathering command is engaged on the propeller pitch control - HC-92()(-2()), HC-93()(-2()), (B)HC-92()F-3(), and HC-92WF-5A propeller models only.
- (4) Increase in engine speed while decreasing airspeed:
- (a) HC-92()(-8()) propeller models:
 - 1 Governor pilot valve is stuck and is excessively decreasing oil volume in the propeller.
 - (b) (B)HC-92()F-1(), HC-92()K-1(), HC-93Z20-1(), HC-92()(-2()), HC-93()(-2()), (B)HC-92()F-3(), and HC-92WF-5A propeller models:
 - 1 Governor pilot valve is stuck and is excessively increasing oil volume.
- (5) Decrease in engine speed while decreasing airspeed:
- (a) HC-92()(-8()) propeller models:
 - 1 Governor is not reducing oil volume in the propeller.
 - 2 Excessive friction in the blade bearings or pitch change mechanism.
 - (b) (B)HC-92()F-1(), HC-92()K-1(), HC-93Z20-1(), HC-92()(-2()), HC-93()(-2()), (B)HC-92()F-3(), and HC-92WF-5A propeller models:
 - 1 Governor is not increasing oil volume in the propeller.
 - 2 Engine oil transfer bearing is leaking excessively.
 - 3 Excessive friction in the blade bearings or the pitch change mechanism.

- D. Loss of Propeller Control - HC-92()()-8() Propeller Models:
- (1) Propeller goes to uncommanded low pitch (high RPM)
 - (a) Loss of propeller oil pressure - check:
 - 1 Governor pressure relief valve for proper operation.
 - 2 Governor pilot valve sticking.
 - 3 Governor drive for damage.
 - 4 Adequate engine oil supply.
 - 5 Engine oil transfer bearing for excessive leakage.
 - (2) Propeller goes to uncommanded high pitch (low RPM)
 - (a) Governor pilot valve sticking.
 - (3) RPM increases with power and airspeed, propeller RPM control has little or no effect.
 - (a) Excessive friction in blade bearings or pitch change mechanism.
 - (b) Misalignment between the guide collar and piston rods.
- E. Loss of Propeller Control - (B)HC-92()F-1(), HC-92()K-1(), HC-93Z20-1(), HC-92()()-2(), HC-93()()-2(), (B)HC-92()F-3(), and HC-92WF-5A Propeller Models:
- (1) Propeller goes to uncommanded high pitch (or feather)
 - (a) Loss of propeller oil pressure - check:
 - 1 Governor pressure relief valve for proper operation.
 - 2 Governor drive for damage.
 - 3 Adequate engine oil supply.
 - 4 Engine oil transfer bearing for excessive leakage.
 - (b) Start locks not engaging -HC-9()()-2() and HC-92WF-5A propeller models only.
 - (2) Propeller goes to uncommanded low pitch (high RPM)
 - (a) Governor pilot valve sticking.
 - (3) RPM increases with power and airspeed, propeller RPM control has little or no effect.
 - (a) Excessive friction in blade bearings or pitch change mechanism.

- (b) Excessive friction in misalignment between the guide collar and the piston rods.
- (c) Broken spring.

NOTE 1: Propeller models (B)HC-92()F-1(), HC-92()K-1() and HC-93Z20-1() do not have a spring.

NOTE 2: Refer to the propeller assembly figures in the Description and Operation chapter of this manual to determine if a spring is installed.

- F. Failure to Feather or Feathers Slowly - HC-92()()-2(), HC-93()()-2(), and HC-92WF-5A Propeller Models:
 - (1) Broken feathering spring.
 - (2) Check for proper function and rigging of propeller/ governor control linkage.
 - (3) Check governor drain function.
 - (4) Propeller must be checked for misadjustment or internal corrosion (usually in blade bearings or pitch changing mechanism) that results in excessive friction. This must be accomplished at a certified propeller repair station with the appropriate rating.
- G. Failure to Unfeather - HC-92()()-2(), HC-93()()-2(), and HC-92WF-5A propeller models.
 - (1) Check for proper function and rigging of the propeller control linkage to the governor.
 - (2) Check governor function.
 - (3) Check for excessive oil leakage at engine oil transfer bearing.
 - (4) Propeller must be checked for misadjustment or internal corrosion (usually in blade bearings or pitch change mechanism) that results in excessive friction. This must be accomplished at a certified propeller repair station with the appropriate rating.

- H. Start Locks (Anti-Feather Latches) Fail to Engage on Shutdown - HC-9() ()-2() () and HC-92WF-5A Propellers:
Refer to the propeller assembly figures in the Description and Operation chapter of this manual to determine if start locks are installed.

- (1) Propeller was feathered before shutdown.

CAUTION: DO NOT PLACE THE BLADE PADDLE IN THE AREA OF THE DE-ICE BOOT WHEN APPLYING TORQUE TO A BLADE ASSEMBLY. PLACE THE BLADE PADDLE IN THE THICKEST AREA OF THE BLADE, JUST OUTSIDE OF THE DE-ICE BOOT. USE ONE BLADE PADDLE PER BLADE.

- (a) Using the blade paddles, simultaneously rotate the blades toward low pitch until the start lock pins engage a clamp mounted stop plate.

- (2) Shutdown occurred at high RPM with the propeller control set for coarse blade angle or low RPM.

CAUTION: DO NOT PLACE THE BLADE PADDLE IN THE AREA OF THE DE-ICE BOOT WHEN APPLYING TORQUE TO A BLADE ASSEMBLY. PLACE THE BLADE PADDLE IN THE THICKEST AREA OF THE BLADE, JUST OUTSIDE OF THE DE-ICE BOOT. USE ONE BLADE PADDLE PER BLADE.

Using the blade paddles, simultaneously rotate the blades toward low pitch until the start lock pins engage a clamp mounted stop plate.

- (3) Excessive engine oil transfer bearing leakage.

- (a) Refer to a certified repair station with the appropriate rating.

- (4) Excessive governor pump leakage.

- (a) Refer to a certified propeller repair station with the appropriate rating.

- (5) Broken start locks.

- (a) Refer to a certified propeller repair station with the appropriate rating.

I. Vibration

CAUTION: ANY VIBRATION THAT CAN BE DESCRIBED AS APPEARING SUDDENLY, OR IS ACCOMPANIED BY UNEXPLAINED GREASE LEAKAGE, SHOULD BE INVESTIGATED IMMEDIATELY, BEFORE FURTHER FLIGHT.

NOTE: Vibration problems due to propeller system imbalance are normally felt throughout the RPM range, with the intensity of vibration increasing with RPM. Vibration problems that occur in a narrow RPM range are a symptom of resonance, which is potentially harmful to the propeller. Avoid operation until the propeller can be checked by an appropriately licensed propeller repair facility.

(1) Check:

- (a) Control surfaces, cowl flaps, exhaust system, landing gear doors, etc. for excessive play, which may be causing vibration unrelated to the propeller.
- (b) Secure attachment of engine mounted hardware.
- (c) Engine mount wear.
- (d) Uneven lubrication of propeller.
- (e) Proper engine/propeller flange mating.
- (f) Blade track. (For procedure, refer to the Inspection and Check chapter of this manual.)
- (g) Blade angles: Blade angle must be within 0.2 degree from blade to blade.
- (h) Spinner for cracks, improper installation, or "wobble" during operation.
- (i) Static balance.
- (j) Airfoil profile identical between blades (after overhaul or rework for nicks - verify at propeller repair station).
- (k) Hub, blade or blade clamp for damage or cracking.
- (l) Grease or oil leakage from a seemingly solid surface of the hub, blade clamp or blade.

(m) Blade deformation.

NOTE: Dynamic balancing is recommended after installing or performing maintenance on a propeller. While normally an optional task, it may be required by the engine or airframe manufacturer to make certain the propeller/engine combination is balanced within close tolerances before operation. Refer to the engine or airframe manuals, and the Maintenance Practices chapter of this manual.

J. Propeller Overspeed

(1) Check:

- (a) Tachometer error.
- (b) Low pitch stop adjustment.
- (c) Governor Maximum RPM set too high.
- (d) Loss of oil pressure - HC-92()(-8)() propeller models.
 - 1 Governor failure
 - 2 Excessive leakage in the governor oil supply to the propeller
- (e) Broken spring causes momentary overspeed - HC-9()(-2(), (B)HC-92()F-3() and HC-92WF-5A propeller models:
- (f) Governor pilot valve jammed, supplying high pressure only HC-9()(-2(), (B)HC-92()F-3() and HC-92WF-5A propeller models.

K. Propeller Underspeed

(1) Check:

- (a) Tachometer error.
- (b) Excessive transfer bearing leakage - HC-9()(-2(), (B)HC-92()F-3() and HC-92WF-5A propeller models.
- (c) Governor oil pressure low - HC-9()(-2(), (B)HC-92()F-3() and HC-92WF-5A propeller models.
- (d) Governor oil passage clogged - HC-92()(-2(), (B)HC-92()F-3() and HC-92WF-5A propeller models.
- (e) Governor pilot valve jammed, supplying high pressure only - HC-92()(-8() propeller models.

L. Oil or Grease Leakage

CAUTION: GREASE LEAKAGE THAT CAN BE DESCRIBED AS EXCESSIVE AND APPEARING SUDDENLY, ESPECIALLY WHEN ACCOMPANIED BY VIBRATION, SHOULD BE INVESTIGATED IMMEDIATELY BEFORE FURTHER FLIGHT.

(1) Grease Leakage - Probable Cause:

NOTE: The blade clamp is the only source of grease leakage.

- (a) Improperly torqued or loose lubrication fitting. (Tighten the fitting).
- (b) Defective lubrication fitting. (Replace the fitting).
- (c) Incorrect O-ring between the blade clamp and the propeller hub. (Refer to a certified propeller repair station with the appropriate rating for replacement of the O-ring).
- (d) Grease leaks past the blade clamp seal gaskets. (Replace gaskets).
- (e) Grease leaks from between the blade clamp and the blade. (Refer to a certified propeller repair station with the appropriate rating for replacement of sealant).

(2) Oil Leakage - Probable Cause

- (a) Faulty O-ring seal between the hub and the cylinder.
- (b) Faulty O-ring seal between the piston and the cylinder.
- (c) Displaced felt seal between the piston and the cylinder
- (d) Faulty O-ring between the propeller hub and the engine flange.
- (e) Faulty O-ring between the piston and the pitch change rod.

(3) Beta System Oil Leakage - Probable Cause

- (a) Governor leaks oil. Refer to an appropriately licensed propeller repair facility for reseal.

- (b) Faulty gasket between the governor and beta valve, or the beta valve and engine. Replace the gasket.
- (c) Faulty O-rings between the beta valve body and beta valve spool. (Refer to an appropriately licensed propeller repair facility for replacement.)

(This page is intentionally blank.)

1. Pre-Flight Checks

CAUTION: INSTRUCTIONS AND PROCEDURES IN THIS SECTION MAY INVOLVE PROPELLER CRITICAL PARTS. REFER TO THE INTRODUCTION CHAPTER OF THIS MANUAL FOR INFORMATION ABOUT PROPELLER CRITICAL PARTS.

Follow propeller preflight inspection procedures as specified in the aircraft maintenance manual or this manual. In addition, perform the following inspections:

A. Blades

- (1) Visually inspect the entire blade (lead and trail edges, and the face and camber sides) for nicks, gouges, and cracks.
 - (a) Normal blade lead edge erosion (a sandblasted appearance) is acceptable and does not require removal prior to flight.
 - (b) Refer to the Maintenance Practices chapter of this manual for blade repair information.
- (2) Visually inspect the blades for lightning strike. Refer to the Lightning Strike Damage section in this chapter for a description of damage.

- B. Inspect the spinner and visible blade retention components for damage or cracks. Repair or replace components as required before further flight.
- C. Check for loose/missing hardware. Retighten or reinstall as necessary.

WARNING: ABNORMAL GREASE LEAKAGE CAN BE AN INDICATION OF A FAILING PROPELLER BLADE OR BLADE RETENTION COMPONENT. AN IN-FLIGHT BLADE SEPARATION CAN RESULT IN A CATASTROPHIC AIRCRAFT ACCIDENT.

- D. Inspect for grease and oil leakage and determine its source.

WARNING: ABNORMAL VIBRATION CAN BE AN INDICATION OF A FAILING PROPELLER BLADE OR BLADE RETENTION COMPONENT. AN IN-FLIGHT BLADE SEPARATION CAN RESULT IN A CATASTROPHIC AIRCRAFT ACCIDENT.

- E. Check the blades for radial play or movement of the blade tip (in and out or back and forth). Refer to Loose Blades, in the Periodic Inspections section of this chapter, for blade play limits.
- F. Inspect de-ice boots (if installed) for damage. Refer to De-ice Systems in the Anti-ice and De-ice Systems chapter of this manual, for inspection information.
- G. Refer to the Periodic Inspections section in this chapter for additional inspection information and possible corrections to any discrepancies discovered as a result of preflight checks.

2. Operational Checks

CAUTION: INSTRUCTIONS AND PROCEDURES IN THIS SECTION MAY INVOLVE PROPELLER CRITICAL PARTS. REFER TO THE INTRODUCTION CHAPTER OF THIS MANUAL FOR INFORMATION ABOUT PROPELLER CRITICAL PARTS.

- A. Following propeller installation and before flight, perform initial run-up as outlined in Operational Tests in the Testing and Troubleshooting chapter of this manual.
- B. Check the propeller speed control and operation from reverse or low pitch to high pitch, using the procedure specified in the Pilot Operating Handbook (POH) for the aircraft.
 - (1) Perform all ground functional, feathering, and cycling checks with a minimum propeller RPM drop required to demonstrate function.
 - (2) A typical RPM drop is 300-500 RPM for feathering propellers and 100 to 300 RPM for non-feathering propellers.

WARNING: ABNORMAL VIBRATION CAN BE AN INDICATION OF A FAILING PROPELLER BLADE OR BLADE RETENTION COMPONENT. AN IN-FLIGHT BLADE SEPARATION CAN RESULT IN A CATASTROPHIC AIRCRAFT ACCIDENT.

- C. Check for any abnormal vibration during this run-up. If vibration occurs, shut the engine down, determine the cause, and correct it before further flight. Refer to the Vibration section in the Testing and Troubleshooting chapter of this manual.
- D. Refer to Periodic Inspections in this chapter for additional inspection information and possible corrections to any discrepancies discovered as a result of Pre-Flight Checks.
- E. Refer to the airframe manufacturer's manual for additional operational checks.

3. Required Periodic Inspections and Maintenance

CAUTION: INSTRUCTIONS AND PROCEDURES IN THIS SECTION MAY INVOLVE PROPELLER CRITICAL PARTS. REFER TO THE INTRODUCTION CHAPTER OF THIS MANUAL FOR INFORMATION ABOUT PROPELLER CRITICAL PARTS.

A. Periodic Inspection

Perform detailed inspection procedures at 100 hour intervals, not to exceed twelve (12) calendar months. Procedures involved in these inspections are detailed below.

NOTE 1: Inspection and maintenance specified by an airframe manufacturer's maintenance program and approved by the applicable airworthiness agency may not coincide with the inspection time interval specified. In this situation the airframe manufacturer's schedule may be applied with the exception that the calendar limit for the inspection interval may not exceed (12) calendar months.

NOTE 2: Refer to Inspection Procedures in this chapter for additional inspection information and possible corrections to any discrepancies discovered as a result of the Periodic Inspection.

- (1) Remove the spinner.
- (2) Visually inspect the blades for nicks, gouges, and cracks. If any damage is discovered, refer to the Blade Repairs section in the Maintenance Practices chapter of this manual for additional information. A cracked blade must be referred to a certified propeller repair station with the appropriate rating.
- (3) Inspect all visible propeller parts for cracks, wear or unsafe conditions.
- (4) Check for oil and grease leaks. Refer to Oil and Grease Leakage in the Inspection Procedures section of this chapter.
- (5) Check the blade track. Refer to Blade Track in the Inspection Procedures section of this chapter.

- (6) Check the accuracy of the tachometer. Refer to Tachometer Inspection in the Inspection Procedures section of this chapter.
 - (7) Clean or replace the anti-ice system filter (if anti-ice system is installed).
 - (8) Make an entry in this log book verifying this inspection.
- B. Periodic Maintenance
- (1) Lubricate the propeller assembly. Refer to the Lubrication section in the Maintenance Practices chapter of this manual for intervals and procedures.
- C. Airworthiness Limitations
- (1) Certain components, as well as the entire propeller may have specific life limits established as part of the certification by the FAA. Such limits call for mandatory replacement of specified parts after a defined number of hours and/or cycles of use.
 - (2) Life limited component times may exist for the propeller models covered in this manual. Refer to the Airworthiness Limitations section of this manual.
 - (3) Refer to the latest revision of Hartzell Propeller Inc. Service Letter HC-SL-61-61Y for life limit data that has not yet been incorporated into the applicable overhaul manual. The service letter is available on the Hartzell Propeller Inc. website at www.hartzellprop.com.

D. Overhaul Periods

In flight, the propeller is constantly subjected to vibration from the engine and the airstream, as well as high centrifugal forces. The propeller is also subject to corrosion, wear, and general deterioration due to aging. Under these conditions, metal fatigue or mechanical failures can occur. To protect your safety and your investment, and to maximize the safe operating lifetime of your propeller, it is essential that a propeller be properly maintained and overhauled according to the recommended service procedures.

CAUTION 1: OVERHAUL PERIODS LISTED BELOW, ALTHOUGH CURRENT AT THE TIME OF PUBLICATION, ARE FOR REFERENCE PURPOSES ONLY. OVERHAUL PERIODS MAY BE INCREASED OR DECREASED AS A RESULT OF ENGINEERING EVALUATION.

CAUTION 2: CHECK THE LATEST REVISION OF HARTZELL PROPELLER INC. SERVICE LETTER 61() FOR THE MOST CURRENT INFORMATION.

(1) Hartzell Propeller Inc. "reciprocating" propellers installed on piston engine aircraft are to be overhauled at intervals as follows:

(a) Agricultural Aircraft - 2000 hours or 36 calendar months (whichever occurs first).

NOTE 1: Agricultural aircraft are defined as aircraft used as aerial applicators, which expose the propeller to a relatively severe chemical/corrosive environment.

NOTE 2: Once the propeller is used on agricultural aircraft, the 36 month overhaul limit is to be maintained even if propeller is later installed on other category airplanes.

- (b) Aerobatic Aircraft - 1000 hours or 60 calendar months (whichever occurs first).

NOTE: Aerobatic aircraft are defined as certificated acrobatic category aircraft or other aircraft routinely exposed to aerobatic use.

- (c) Jacobs R-755 engine applications - 1000 hours or 60 calendar months (whichever occurs first).
- (d) All others - 2000 hours or 60 calendar months, whichever occurs first.

4. Inspection Procedures

CAUTION: INSTRUCTIONS AND PROCEDURES IN THIS SECTION MAY INVOLVE PROPELLER CRITICAL PARTS. REFER TO THE INTRODUCTION CHAPTER OF THIS MANUAL FOR INFORMATION ABOUT PROPELLER CRITICAL PARTS.

The following inspections are made on a regular basis, either before flight, during the periodic inspection, or if a problem is noted. Possible corrections to problems discovered during inspections, additional inspections, and limits are detailed in the following inspection procedures.

A. Blade Damage

Refer to Blade Repairs section in the Maintenance Practices chapter of this manual for information regarding blade damage.

B. Grease or Oil Leakage

NOTE: A new or newly overhauled propeller may leak slightly during the first several hours of operation. This leakage may be caused by the seating of seals and O-rings, and the slinging of lubricants used during assembly. Such leakage should cease within the first ten hours of operation.

Leakage that persists beyond the first ten hours of operation on a new or newly overhauled propeller, or occurs on a propeller that has been in service for some time will require repair. A determination should be made as to the source of the leak. The only leakage that is field repairable is the removal and replacement of the O-ring seal between the engine and propeller flange. All other leakage repairs should be referred to a certified propeller repair station with the appropriate rating. An instance of abnormal grease leakage should be inspected using the following procedure:

- (1) Remove the spinner dome.

CAUTION: PERFORM A VISUAL INSPECTION WITHOUT CLEANING THE PARTS. A TIGHT CRACK IS OFTEN EVIDENT BECAUSE OF GREASE TRACES EMANATING FROM THE CRACK. CLEANING CAN REMOVE SUCH EVIDENCE AND MAKE A CRACK VIRTUALLY IMPOSSIBLE TO SEE.

- (2) Perform a visual inspection of the hub, blade clamps and blades to locate the origin of leakage. If the origin of the grease leakage is determined to be a noncritical part, such as an O-ring, gasket or sealant, repairs can be accomplished during scheduled maintenance as long as flight safety is not compromised.
- (3) If cracks are suspected, additional inspections must be performed by qualified personnel at a certified propeller repair station with the appropriate rating, to verify the condition before further flight. Such inspections typically include disassembly of the propeller followed by inspection of parts, using nondestructive methods in accordance with published procedures.
- (4) If cracks or failing components are found, these parts must be replaced before further flight. Report such occurrences to airworthiness authorities and to Hartzell Propeller Inc. Product Support.

C. Vibration

Instances of abnormal vibration should be investigated immediately. If the cause of the vibration is not readily apparent, the propeller may be inspected following the procedure below:

NOTE: It may sometimes be difficult to readily identify the cause of abnormal vibration. Vibration may originate in the engine, propeller, or airframe. Troubleshooting procedures typically begin with an investigation of the engine. Airframe components, such as engine mounts or loose landing gear doors, can also be the source of vibration. When investigating an abnormal vibration, the possibility of a failing blade or blade retention component should be considered as a potential source of the problem.

- (1) Perform troubleshooting and evaluation of possible sources of vibration in accordance with engine or airframe manufacturer's instructions.
- (2) Refer to Vibration section in the Testing and Troubleshooting chapter of this manual. Perform the checks to determine possible cause of the vibration. If no cause is found, then consider that the origin of the problem could be the propeller and proceed with steps 4.C.(3) through 4.C.(8) in this chapter.
- (3) Remove the spinner dome.
- (4) Perform a visual inspection for cracks in the hub, blade clamps and blades.

NOTE: A crack may be readily visible or may be indicated by grease leaking from a seemingly solid surface.

- (5) If cracks are suspected, additional inspections must be performed before further flight. These inspections must be performed by qualified personnel at a certified propeller repair station with the appropriate rating, to verify the condition. Such inspections typically include disassembly of the propeller followed by inspection of parts, using nondestructive methods in accordance with published procedures.

- (6) Check the blades and compare blade-to-blade differences:
 - (a) Inspect the propeller blades for unusual looseness or movement. Refer to Loose Blades section of this chapter.
 - (b) Check blade track. Refer to Blade Track section of this chapter.

CAUTION: DO NOT USE BLADE PADDLES TO TURN BLADES.

- (c) Manually (by hand) attempt to turn the blades (change pitch). Do not use a blade paddles.
 - (d) Visually check for damaged blades.
- (7) If abnormal blade conditions or damage are found, perform additional inspections (by qualified personnel at certified propeller repair station with the appropriate rating) to evaluate the condition. Refer to Blade Repairs section in Maintenance Practices chapter of this manual.
 - (8) If cracks or failing components are found, these parts must be replaced before further flight. Report such occurrences to airworthiness authorities and Hartzell Propeller Inc. Product Support.

D. Tachometer Inspection

WARNING: OPERATION WITH AN INACCURATE TACHOMETER MAY RESULT IN OPERATION AT A RESTRICTED RPM AND DAMAGING HIGH STRESSES. BLADE LIFE WILL BE SHORTENED AND COULD RESULT IN CATASTROPHIC FAILURE.

- (1) Use a hand held tachometer to verify the accuracy of the engine tachometer at 100 hour intervals or at annual inspection, whichever occurs first.

NOTE: An appropriately licensed propeller repair facility may also be able to perform an engine tachometer inspection.

- (2) Hartzell Propeller Inc recommends using a tachometer that is accurate within +/- 10 RPM, has NIST calibration (traceable), and has an appropriate calibration schedule.

APS6155

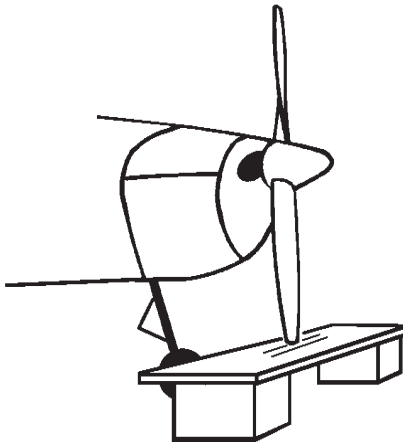

**Checking Blade Track
Figure 5-1**

APS6163

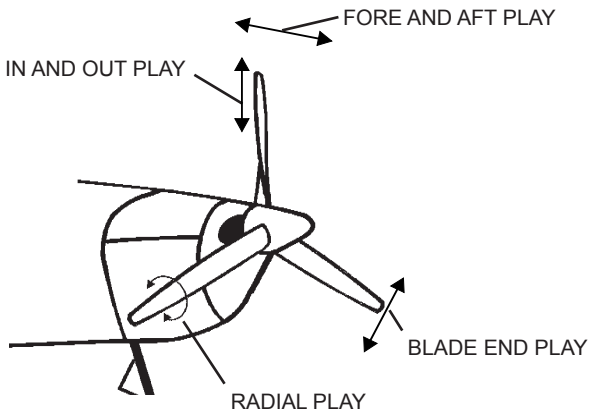

**Blade Play
Figure 5-2**

E. Blade Track

(1) Check the blade track as follows:

- (a) Chock the aircraft wheels securely.
- (b) Refer to Figure 5-1. Place a fixed reference point beneath the propeller, within 0.25 inch (6.0 mm) of the lowest point of the propeller arc.

NOTE: This reference point may be a flat board with a sheet of paper attached to it. The board may then be blocked up to within 0.25 inch (6.0 mm) of the propeller arc.

WARNING: MAKE SURE THE ENGINE MAGNETO IS GROUNDED (OFF) BEFORE ROTATING THE PROPELLER.

- (c) Rotate the propeller by hand (the opposite direction of normal rotation) until a blade points directly at the paper. Mark the position of the blade tip in relation to the paper.
- (d) Repeat this procedure with the remaining blades.
- (e) Tracking tolerance is ± 0.06 inch (1.5 mm) or 0.12 inch (3.0 mm) total.

(2) Possible Correction

- (a) Remove foreign matter from the propeller mounting flange.
- (b) If no foreign matter is present, refer to a certified propeller repair station with the appropriate rating.

F. Loose Blades

Refer to Figure 5-2. Limits for blade looseness are as follows:

End Play	± 0.06 inch (1.5 mm)
Fore & Aft Movement	± 0.06 inch (1.5 mm)
In and Out	0.032 inch (0.813 mm)
Radial Play (pitch change)	± 0.5 degree (1 degree total)

Blade movement beyond these limits should be referred to a certified propeller repair station with the appropriate rating.

G. Corrosion

WARNING: REWORK THAT INVOLVES COLD WORKING THE METAL, RESULTING IN CONCEALMENT OF A DAMAGED AREA IS NOT PERMITTED.

Light corrosion on blades may be removed by qualified personnel in accordance with the Blade Repairs section in the Maintenance Practices chapter of this manual.

Heavy corrosion that results in severe pitting must be referred to a certified propeller repair station with the appropriate rating.

H. Spinner Damage

Inspect the spinner for cracks, missing hardware, or other damage. Refer to a certified propeller repair station with the appropriate rating. for spinner damage acceptance and repair information. Refer to Hartzell Propeller Inc. Metal Spinner Assembly Maintenance Manual 127 (61-16-27) for approved field repairs to metal spinners. Contact the local airworthiness authority for repair approval.

I. Electric De-ice System

Refer to the Anti-Ice and De-ice Systems chapter of this manual for inspection procedures.

J. Anti-ice System

Refer to the Anti-Ice and De-ice Systems chapter of this manual for inspection procedures.

5. Special Inspections

CAUTION: INSTRUCTIONS AND PROCEDURES IN THIS SECTION MAY INVOLVE PROPELLER CRITICAL PARTS. REFER TO THE INTRODUCTION CHAPTER OF THIS MANUAL FOR INFORMATION ABOUT PROPELLER CRITICAL PARTS.

A. Overspeed

An overspeed has occurred when the propeller RPM has exceeded the maximum RPM stated in the applicable Aircraft Type Certificate Data Sheet. The duration of time and magnitude of overspeed for a single event determines the corrective action that must be taken to ensure no damage to the propeller has occurred.

The criteria for determining the required action after an overspeed are based on many factors. The additional centrifugal forces that occur during overspeed are not the only concern. Some applications have sharp increases in vibratory stresses at RPMs above the maximum rated for the airframe/ engine/propeller combination

- (1) When a propeller installed on a reciprocating engine has an overspeed event, refer to the Reciprocating Engine Overspeed Limits (Figure 5-3) to determine the corrective action to be taken.
- (2) Make a log book entry to document the overspeed event.

B. Lightning Strike

CAUTION: ALSO CONSULT ENGINE AND AIRFRAME MANUFACTURER'S MANUALS. THERE MAY BE ADDITIONAL REQUIREMENTS SUCH AS DE-ICE AND ENGINE SYSTEM CHECKS TO PERFORM AFTER A PROPELLER LIGHTNING STRIKE.

(1) General

In the event of a propeller lightning strike, an inspection is required before further flight. It may be permissible to operate a propeller for an additional ten (10) hours of operation if the propeller is not severely damaged and meets the requirements in paragraph 5.B.(2). Regardless of the outcome of the initial inspection, the propeller must eventually be removed from the aircraft, disassembled, evaluated, and/or repaired by a certified propeller repair station with the appropriate rating.

(2) Procedure for Temporary Operation

If temporary additional operation is desired before propeller removal and disassembly:

- (a) Remove spinner dome and perform visual inspection of propeller, spinner, and de-ice system for evidence of significant damage that would require repair before flight (such as broken de-ice wires or arcing damage to propeller hub).

CAUTION: IF THE PROPELLER EXPERIENCES LIGHTNING STRIKE, THE ALUMINUM BLADES MUST BE WITHIN AIRWORTHY LIMITS FOR ANY ADDITIONAL FLIGHT.

- (b) If the only evident damage is minor arcing burns to the blades, then operation for ten (10) hours is acceptable before disassembly and inspection.
- (c) Perform a functional check of the propeller de-ice system (if installed) in accordance with aircraft maintenance manual procedures.

- (d) Regardless of the degree of damage, make a log book entry to document the lightning strike.
- (e) The propeller must be removed from the aircraft, disassembled, evaluated, and/or repaired by a certified propeller repair station with the appropriate rating. for flight beyond the temporary operation limits granted above.

C. Foreign Object Strike/Ground Strike**(1) General**

- (a) A foreign object strike can include a broad spectrum of damage, from a minor stone nick to severe ground impact damage. A conservative approach in evaluating the damage is required because there may be hidden damage that is not readily apparent during an on-wing, visual inspection.
- (b) A foreign object strike is defined as:
 - 1 Any incident, whether or not the engine is operating, that requires repair to the propeller other than minor dressing of the blades. Examples of foreign object strike include situations where an aircraft is stationary and the landing gear collapses causing one or more blades to be significantly damaged, or where a hangar door (or other object) strikes the propeller blade. These cases should be handled as foreign object strikes because of potentially severe side loading on the propeller hub, blades and retention bearings.
 - 2 Any incident during engine operation in which the propeller impacts a solid object that causes a drop in revolutions per minute (RPM) and also requires structural repair of the propeller (incidents requiring only paint touch-up are not included). This is not restricted to propeller strikes against the ground.
 - 3 A sudden RPM drop while impacting water, tall grass, or similar yielding medium, where propeller blade damage is not normally incurred.

(2) Procedure

- (a) In the event of a foreign object strike, an inspection is required before further flight. If the inspection reveals one or more of the following indications, the propeller must be removed from the aircraft, disassembled and overhauled in accordance with the applicable propeller and blade maintenance manuals.
 - 1 A blade rotated in the clamp.
 - 2 Any noticeable or **suspected** damage to the pitch change mechanism.
 - 3 A bent blade (out of track or angle).
 - 4 Any diameter reduction.
 - 5 Blade Damage.
 - 6 A bent, cracked, or failed engine shaft.
 - 7 Vibration during operation that was not present before the event.
- (b) Nicks, gouges, and scratches on blade surfaces or the leading and trailing edges must be removed before flight. Refer to the Blade Repairs section in the Maintenance Practices chapter of this manual.
- (c) Engine mounted components - such as governors, pumps, etc. may be damaged by a foreign object strike, especially if the strike resulted in a sudden stoppage of the engine. These components should be inspected, repaired, or overhauled as recommended by the applicable component maintenance manual.
- (d) Make an entry in the propeller log book to document the foreign object strike/ground strike incident and any corrective action(s) taken.

D. Fire Damage or Heat Damage

WARNING: HUBS AND CLAMPS ARE MANUFACTURED FROM HEAT TREATED FORGINGS AND ARE SHOT PEENED. BLADES ARE MANUFACTURED FROM HEAT TREATED FORGINGS AND ARE COMPRESSIVELY ROLLED AND SOMETIMES SHOT PEENED. EXPOSURE TO HIGH TEMPERATURES CAN DESTROY THE FATIGUE BENEFITS OBTAINED FROM THESE PROCESSES.

On rare occasions propellers may be exposed to fire or heat damage, such as an engine or hangar fire. In the event of such an incident, an inspection by a certified propeller repair station with the appropriate rating, is required before further flight.

6. Long Term Storage

- A.** Parts shipped from the Hartzell Propeller Inc. factory are not shipped or packaged in a container that is designed for long term storage.
- B.** Long term storage procedures may be obtained by contacting a Hartzell Propeller Inc. distributor, or the Hartzell Propeller Inc. factory via the product support number listed in the Introduction chapter of this manual. Storage information is also detailed in Hartzell Propeller Inc. Standard Practices Manual 202A (61-01-02).
- C.** Information regarding the return of a propeller assembly to service after long term storage may be obtained by contacting a Hartzell Propeller Inc. distributor, or the Hartzell Propeller Inc. factory via the product support number listed in the Introduction chapter of this manual. This information is also detailed in Hartzell Propeller Inc. Standard Practices Manual 202A (61-01-02).

CONTENTS

1. Cleaning.....	6-3
A. General Cleaning.....	6-3
B. Spinner Cleaning and Polishing	6-3
2. Lubrication	6-5
A. Lubrication Intervals	6-5
B. Lubrication Procedure	6-6
C. Approved Lubricants.....	6-9
3. Carbon Block Assemblies	6-10
A. Inspection	6-10
B. Replacement of A-3026 Carbon Block Unit in the A-3044 Carbon Block Assembly	6-10
C. Installation of the A-3044 Carbon Block Assembly	6-11
4. Blade Repairs	6-13
A. Repair of Nicks or Gouges	6-13
B. Repair of Bent Blades.....	6-15
5. Painting After Repair.....	6-16
A. General.....	6-16
B. Painting of Aluminum Blades.....	6-17
6. Dynamic Balance.....	6-19
A. Overview.....	6-19
B. Inspection Procedures Before Balancing	6-20
C. Placement of Balance Weights for Dynamic Balance....	6-21
7. Propeller Low Pitch Setting.....	6-23
A. Low Pitch Stop - All Propeller Models	6-23
B. Low pitch measurement on propeller models HC-9() () -2() () :	6-24
C. Low pitch measurement on propeller models (B)HC-9() () -1() () and HC-92() () -8() :	6-24

CONTENTS

D. Low pitch measurement on propeller models HC-92()(-)3() and HC-92WF-5A.....	6-25
E. Adjusting Low Pitch Angle - Propeller Models BHC-92()f-3() () and HC-92WF-5A	6-25
8. High Pitch (Minimum RPM) Stop - Propeller models HC-9() ()(-)1() () (), HC-92() ()(-)3() () , and HC-92() ()(-)8()	6-28
9. Feathering Pitch Stop Adjustment - Propeller Models HC-9() ()(-)2() () and HC-92WF-5A.....	6-28
10. Start Lock Adjustment - Propeller models HC-9() ()(-)2() () and HC-92WF-5A.....	6-28
11. Propeller Ice Protection Systems.....	6-28

LIST OF FIGURES

Lubrication Fitting	Figure 6-1	6-4
Lubrication Label	Figure 6-2	6-6
Repair Limitations.....	Figure 6-3	6-12
Location of Balance Weights	Figure 6-4	6-22
Adjusting Low Pitch Angle	Figure 6-5.....	6-26

LIST OF TABLES

Approved Touch-up Paints	Table 6-1	6-17
--------------------------------	-----------------	------

1. Cleaning

CAUTION 1: INSTRUCTIONS AND PROCEDURES IN THIS SECTION MAY INVOLVE PROPELLER CRITICAL PARTS. REFER TO THE INTRODUCTION CHAPTER OF THIS MANUAL FOR INFORMATION ABOUT PROPELLER CRITICAL PARTS.

CAUTION 2: DO NOT USE PRESSURE WASHING EQUIPMENT TO CLEAN THE PROPELLER OR CONTROL COMPONENTS. PRESSURE WASHING CAN FORCE WATER AND/OR CLEANING SOLVENTS PAST SEALS, AND LEAD TO INTERNAL CORROSION OF PROPELLER COMPONENTS.

A. General Cleaning

CAUTION 1: WHEN CLEANING THE PROPELLER, DO NOT PERMIT SOAP OR SOLVENT SOLUTIONS TO RUN OR SPLASH INTO THE HUB AREA.

CAUTION 2: DO NOT CLEAN PROPELLER WITH CAUSTIC OR ACIDIC SOAP SOLUTIONS. IRREPARABLE CORROSION OF PROPELLER COMPONENTS MAY OCCUR.

(1) Wash propeller with a non-corrosive soap solution.

CAUTION: DO NOT USE ANY SOLVENT DURING CLEANING THAT COULD SOFTEN OR DESTROY THE BOND BETWEEN CHEMICALLY ATTACHED PARTS.

(2) To remove grease or oil from propeller surfaces, apply Stoddard Solvent or equivalent to a clean cloth and wipe the part clean.

(3) Thoroughly rinse with water and permit to dry.

B. Spinner Cleaning and Polishing

(1) Clean the spinner using the General Cleaning procedures above.

(2) Polish the dome (if required) with an automotive-type aluminum polish.

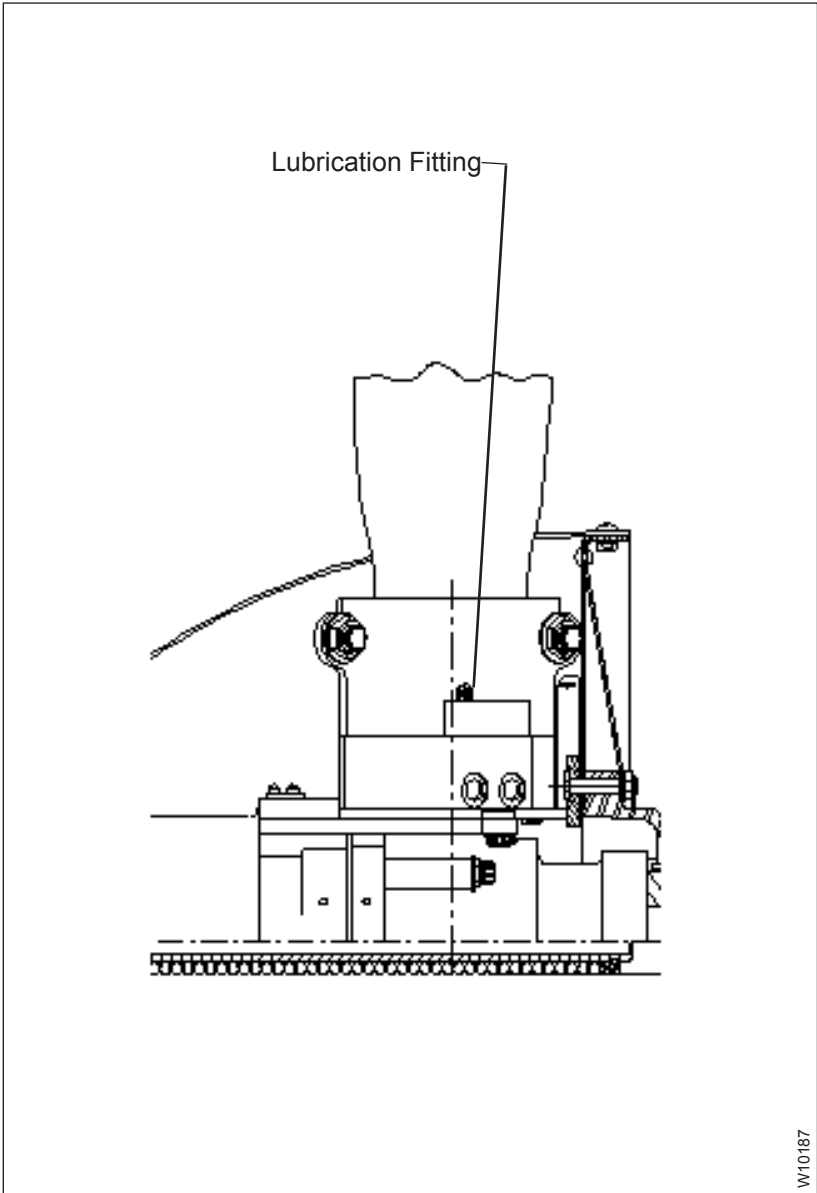

W10187

Lubrication Fitting
Figure 6-1

2. Lubrication

CAUTION: INSTRUCTIONS AND PROCEDURES IN THIS SECTION MAY INVOLVE PROPELLER CRITICAL PARTS. REFER TO THE INTRODUCTION CHAPTER OF THIS MANUAL FOR INFORMATION ABOUT PROPELLER CRITICAL PARTS.

A. Lubrication Intervals

- (1) The propeller is to be lubricated at intervals not to exceed 100 hours or at 12 calendar months, whichever occurs first.

NOTE 1: If annual operation is significantly less than 100 hours, calendar lubrication intervals should be reduced to six months.

NOTE 2: If the aircraft is operated or stored under adverse atmospheric conditions, e.g., high humidity, salt air, calendar lubrication intervals should be reduced to six months.

- (2) Owners of high use aircraft may wish to extend their lubrication intervals. Lubrication interval may be gradually extended after evaluation of previous propeller overhauls, with regard to bearing wear and internal corrosion.
- (3) New or newly overhauled propellers should be lubricated after the first one or two hours of operation, because centrifugal loads will pack and redistribute lubricant.

NOTE: Purchasers of new aircraft should check the propeller logbook to verify whether the propeller was lubricated by the manufacturer during flight testing. If not, the propeller should be serviced at earliest convenience.

B. Lubrication Procedure

CAUTION: FOLLOW LUBRICATION PROCEDURES CORRECTLY TO MAINTAIN AN ACCURATE BALANCE OF THE PROPELLER ASSEMBLY.

- (1) Remove the propeller spinner.
- (2) Refer to Figure 6-1. Each blade clamp has two lubrication fittings. Remove both lubrication fitting caps and one of the lubrication fittings from each blade clamp.

NOTE: Certain steel blade clamps produced before 1967 may have only one fitting, which must be carefully relubricated without excessive pressure.

- (3) Use a piece of safety wire to loosen any blockage or hardened lubricant at the threaded holes where the lubrication fitting was removed.

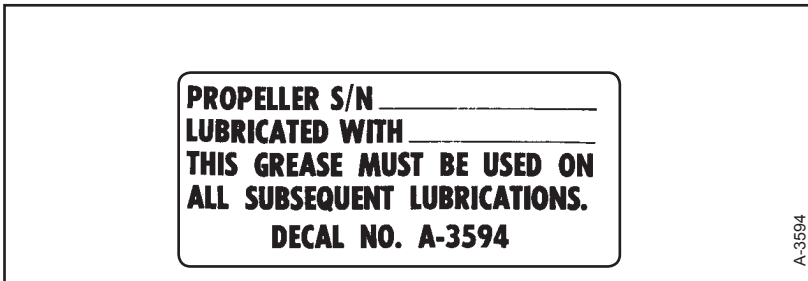

Lubrication Label
Figure 6-2

WARNING: WHEN MIXING AEROSHELL GREASES 5 AND 6, AEROSHELL GREASE 5 MUST BE INDICATED ON THE LABEL (HARTZELL PROPELLER INC. P/N A-3594) AND THE AIRCRAFT MUST BE PLACARDED TO INDICATE THAT FLIGHT IS PROHIBITED IF THE OUTSIDE AIR TEMPERATURE IS LESS THAN -40°F (-40°C).

CAUTION: USE HARTZELL PROPELLER INC. APPROVED GREASE ONLY. EXCEPT IN THE CASE OF AEROSHELL GREASES 5 AND 6, DO NOT MIX DIFFERENT SPECIFICATIONS AND/OR BRANDS OF LUBRICANT.

- (4) Aeroshell greases 5 and 6 both have a mineral oil base and have the same thickening agent; therefore, mixing of these two greases is acceptable in Hartzell Propeller Inc. propellers.
- (5) A label (Hartzell Propeller Inc. P/N A-3494) is normally applied to the propeller to indicate the type of grease previously used. Refer to Figure 6-2.
 - (a) This grease type should be used during re-lubrication unless the propeller has been disassembled and the old grease removed.
 - (b) Purging of old grease through lubrication fittings is only about 30% effective.
 - (c) To completely replace one grease with another, the propeller must be disassembled in accordance with the applicable overhaul manual.

CAUTION 1: IF A PNEUMATIC GREASE GUN IS USED, EXTRA CARE MUST BE TAKEN TO AVOID EXCESSIVE PRESSURE BUILDUP.

CAUTION 2: GREASE MUST BE APPLIED TO ALL BLADES OF A PROPELLER ASSEMBLY AT THE TIME OF LUBRICATION.

(6) Apply Lubricant

(a) Blade clamps with two lubrication fittings:

Pump lubricant into each blade clamp lubricant fitting until lubrication emerges from the hole of the removed lubrication fitting.

NOTE: Lubrication is complete when grease emerges in a steady flow with no air pockets or moisture, and has the color and texture of the new grease.

(b) Blade clamps that have only one lubrication fitting:

Without using excessive pressure, add a small amount (1 to 2 fluid ounces) of lubricant equally to the lubrication fitting in each blade clamp.

(7) Reinstall the removed lubrication fitting on each clamp.

(8) Tighten the lubrication fittings until snug.

NOTE: Make sure the ball of each lubrication fitting is properly seated.

(9) Install a new lubrication fitting cap on each lubrication fitting.

C. Approved Lubricants

- (1) The following lubricants are approved for use in Hartzell Propeller Inc. propellers:

Aeroshell 6 - Recommended "all purpose" grease. Used in most new production propellers since 1989. Higher leakage/oil separation than Aeroshell 5 at higher temperatures (approximately 100°F [38°C]).

Aeroshell 5 - Good high temperature qualities, very little oil separation or leakage. Cannot be used in temperatures colder than -40°F (-40°C). Aircraft serviced with this grease must be placarded to indicate that flight is prohibited if the outside air temperature is less than -40°F (-40°C).

Aeroshell 7 - Good low temperature grease, but high leakage/oil separation at higher temperatures. This grease has been associated with sporadic problems involving seal swelling.

Aeroshell 22 - Qualities similar to Aeroshell 7.

Royco 22CF - Not widely used. Qualities similar to Aeroshell 22.

- (2) A label indicating the type of grease used for previous lubrication (if used) is installed on the propeller piston or on the blade clamp. If the propeller is to be lubricated with a different type of grease, the propeller must be disassembled and cleaned of old grease before relubricating. Refer to Figure 6-2.

3. Carbon Block Assemblies

CAUTION: INSTRUCTIONS AND PROCEDURES IN THIS SECTION MAY INVOLVE PROPELLER CRITICAL PARTS. REFER TO THE INTRODUCTION CHAPTER OF THIS MANUAL FOR INFORMATION ABOUT PROPELLER CRITICAL PARTS.

A. Inspection

The clearance between the yoke pin and the corresponding linkage (beta lever bushing) can become too close due to a buildup of plating and foreign particles between the two pieces. This can cause a binding action, resulting in excessive wear to the carbon block, low stop collar, and beta linkage.

(1) Inspect the beta lever and carbon block interface for free movement. If there is binding, do the following:

(a) Disconnect the beta linkage and remove the carbon block assemblies from the beta ring.

(b) Using an abrasive pad, for example Scotch-brite®, polish the yoke pin to provide adequate clearance and eliminate binding.

(c) Reinstall the carbon block assembly into the beta ring.

NOTE: Use a dry lubricant between the yoke pin and beta lever.

(d) Install, adjust and safety the beta linkage in accordance with the airframe manufacturer's instructions.

B. Replacement of A-3026 Carbon Block Unit in the A-3044 Carbon Block Assembly

Replace an A-3026 carbon block unit if the side clearance between the beta ring and carbon block exceeds 0.010 inch (0.25 mm).

(1) Remove the cotter pin from the end of the clevis pin.

(2) Slide the pin from the assembly and remove and discard the carbon block unit.

(3) Inspect the yoke for wear or cracks. Replace the yoke, if necessary.

- (4) Install a new carbon block unit and slide a new clevis pin into place.
 - (5) Secure the clevis pin with a T-head cotter pin. Refer to Figure 3-15.
 - (6) Refit the carbon block. Refer to Figure 3-14.
 - (a) Establish the required clearance by sanding the sides of the carbon block as needed.
- C. Installation of the A-3044 Carbon Block Assembly
Refer to Installation and Removal chapter of this manual for installation instructions.

APS6157

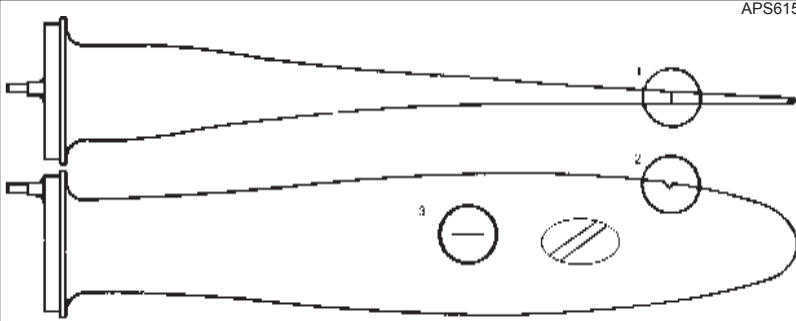

Example 1

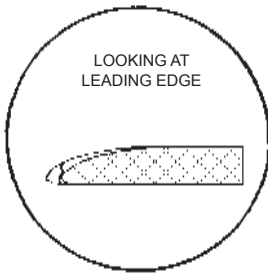

Example 2

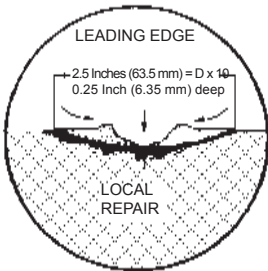

Example 3

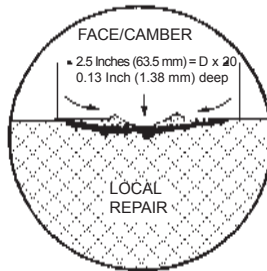

To determine amount of rework needed, use the following formula:

On the leading and trailing edge of the blade, measure the depth of the damage, and multiply this number x 10 (see Example 2, above). Rework the area surrounding the damage 10 times the depth of the damage.

On the face and camber of the blade, measure the depth of the damage, and multiply this number x 20 (see Example 3, above). Rework the area surrounding the damage 20 times the depth of the damage.

Repair Limitations Figure 6-3

4. Blade Repairs

WARNING: THE 1/32 INCH (0.793 MM) WIDE OR DEEP DAMAGE LIMIT IS A GUIDELINE ONLY. ALL NICKS, GOUGES, OR SCRATCHES OF ANY SIZE CAN CREATE A STRESS RISER THAT COULD POTENTIALLY LEAD TO BLADE CRACKING. ALL DAMAGE MUST BE VISUALLY EXAMINED BEFORE FLIGHT FOR THE PRESENCE OF CRACKS OR OTHER ABNORMALITIES.

CAUTION 1: BLADES THAT HAVE BEEN PREVIOUSLY REPAIRED OR OVERHAULED MAY HAVE BEEN DIMENSIONALLY REDUCED. BEFORE REPAIR OF SIGNIFICANT DAMAGE OR MAKING REPAIRS ON A BLADES THAT MAY BE APPROACHING SERVICEABLE LIMITS, CONTACT A CERTIFIED PROPELLER REPAIR STATION OR HARTZELL PROPELLER INC. PRODUCT SUPPORT DEPARTMENT FOR BLADE DIMENSIONAL LIMITS.

CAUTION 2: INSTRUCTIONS AND PROCEDURES IN THIS SECTION MAY INVOLVE PROPELLER CRITICAL PARTS. REFER TO THE INTRODUCTION CHAPTER OF THIS MANUAL FOR INFORMATION ABOUT PROPELLER CRITICAL PARTS.

Nicks, gouges, and scratches on blade surfaces or on the leading or trailing edges of the blade, greater than 1/32 inch (0.793 mm) must be removed before flight. Field repair of small nicks and scratches may be performed by qualified personnel in accordance with FAA Advisory Circular 43.13-1B, as well as the procedures specified below.

A. Repair of Nicks or Gouges

Local repairs may be made using files, electrical or air powered equipment. Emery cloth, scotch brite, and crocus cloth are to be used for final finishing. Refer to Figure 6-3.

CAUTION 1: REWORK THAT INVOLVES COLD WORKING THE METAL, RESULTING IN CONCEALMENT OF A DAMAGED AREA, IS NOT ACCEPTABLE. A STRESS CONCENTRATION MAY EXIST, WHICH CAN RESULT IN A BLADE FAILURE.

CAUTION 2: SHOTPEENED BLADES ARE IDENTIFIED WITH AN "S" FOLLOWING THE BLADE MODEL NUMBER, AS DESCRIBED IN THE DESCRIPTION AND OPERATION CHAPTER OF THIS MANUAL. BLADES THAT HAVE BEEN SHOT PEENED (AS INDICATED BY A "PEBBLE GRAIN" SURFACE) THAT HAVE DAMAGE IN THE SHOT PEENED AREAS IN EXCESS OF 0.015 INCH (0.38 MM) DEEP ON THE FACE OR CAMBER OR 0.250 INCH (6.35 MM) ON THE LEADING OR TRAILING EDGES MUST BE REMOVED FROM SERVICE, AND THE REWORKED AREA SHOT PEENED BEFORE FURTHER FLIGHT. SHOT PEENING OF AN ALUMINUM BLADE MUST BE ACCOMPLISHED BY A CERTIFIED PROPELLER REPAIR STATION WITH THE APPROPRIATE RATING IN ACCORDANCE WITH HARTZELL PROPELLER INC. ALUMINUM BLADE OVERHAUL MANUAL 133C (61-13-33).

- (1) Repairs to the leading or trailing edge are to be accomplished by removing material from the bottom of the damaged area. Remove material from this point out to both sides of the damage, providing a smooth, blended depression which maintains the original airfoil general shape.
- (2) Repairs to the blade face or camber should be made in the same manner as above. Repairs that form a continuous line across the blade section (chordwise) are unacceptable.

- (3) The area of repair should be determined as follows:
Leading and trailing edge damage: Depth of nick x 10.
Face and camber: Depth of nick x 20. Refer to Figure 6-3.

NOTE: Leading edge includes the first 10 percent of chord from the leading edge. The trailing edge consists of the last 20 percent of chord adjacent to the trailing edge.

- (4) After filing or sanding the damaged area, the area must then be polished, first with emery cloth, Scotch-brite®, and finally with crocus cloth to remove any traces of filing.
- (5) Inspect the repaired area with a 10X magnifying glass. Make sure that no indication of the damage, file marks, or coarse surface finish remain.
- (6) If inspection shows any remaining blade damage, repeat steps 4.A.(4) and 4.A.(5) until no damage remains. Dye penetrant inspection is recommended in accordance with Hartzell Propeller Inc. Manual 202A (61-01-02).
- (7) Apply chemical conversion coating and approved paint to the repaired area before returning the blade to service. Refer to the Painting After Repair section in this chapter.

B. Repair of Bent Blades

CAUTION: DO NOT ATTEMPT TO "PRE-STRAIGHTEN" A BLADE BEFORE DELIVERY TO A CERTIFIED PROPELLER REPAIR STATION WITH THE APPROPRIATE RATING. THIS WILL CAUSE THE BLADE TO BE SCRAPPED BY THE REPAIR STATION.

Repair of a bent blade or blades is considered a major repair. This type of repair must be accomplished by a certified propeller repair station with the appropriate rating, and only within approved guidelines.

5. Painting After Repair

A. General

- (1) Propeller blades are painted with a durable specialized coating that is resistant to abrasion. If this coating becomes eroded, it is necessary to repaint the blades to provide proper corrosion and erosion protection. Painting should be performed by a certified propeller repair station with the appropriate rating in accordance with Hartzell Propeller Inc. Standard Practices Manual 202A (61-01-02).
- (2) It is permitted to perform a blade touch-up with aerosol paint in accordance with the procedures in Painting of Aluminum Blades that follows.
- (3) Refer to Table 6-1 for paints that are approved for blade touch-up.
- (4) The paint manufacturers may be contacted via the information below:

Tempo Products Co.

A plasti-kote Company
1000 Lake Road
Medina, OH 44256
Tel: 800.321.6300
Fax: 440.248.1348
Cage Code: 07708

Sherwin Williams Co.

2390 Arbor Boulevard
Dayton, Ohio
Tel: 937.298.8691
Fax: 937.298.3820
Cage Code: 0W199

B. Painting of Aluminum Blades

WARNING: CLEANING AGENTS (ACETONE, #700 LACQUER THINNER, AND MEK), ARE FLAMMABLE AND TOXIC TO THE SKIN, EYES AND RESPIRATORY TRACT. SKIN AND EYE PROTECTION ARE REQUIRED. AVOID PROLONGED CONTACT. USE IN WELL VENTILATED AREA.

CAUTION: ANY REFINISHING PROCEDURE CAN ALTER PROPELLER BALANCE. PROPELLERS THAT ARE OUT OF BALANCE MAY EXPERIENCE EXCESSIVE VIBRATIONS WHILE IN OPERATION.

- (1) Using acetone, #700 lacquer thinner, or MEK, wipe the surface of the blade to remove any contaminants.

Vendor	Color/Type	Vendor P/N	Hartzell P/N
Tempo	Epoxy Black	A-150	n/a
Tempo	Epoxy Gray	A-151	n/a
Tempo	Epoxy White (tip stripe)	A-152	n/a
Tempo	Epoxy Red (tip stripe)	A-153	n/a
Tempo	Epoxy Yellow (tip stripe)	A-154	n/a
Sherwin-Williams	Black	F75KXB9958-4311	A-6741-145-1
Sherwin-Williams	Gray	F75KXA10445-4311	A-6741-146-1
Sherwin-Williams	White (tip stripe)	F75KXW10309-4311	A-6741-147-1
Sherwin-Williams	Red (tip stripe)	F75KXR12320-4311	A-6741-149-1
Sherwin-Williams	Yellow (tip stripe)	F75KXY11841-4311	A-6741-150-1
Sherwin-Williams	Silver	F75KXS13564-4311	A-6741-190-1

**Approved Touch-up Paints
Table 6-1**

- (2) Feather the existing coatings away from the eroded or repaired area with 120 to 180 grit sandpaper.

NOTE: Paint erosion is typically very similar on all blades in a propeller assembly. If one blade has more extensive damage, e.g. in the tip area, all the blades should be sanded in the tip area to replicate the repair of the most severely damaged blade tip. This practice is essential in maintaining balance after refinishing.

- (3) Use acetone, #700 lacquer thinner, or MEK to wipe the surface of the blade. Permit solvent to evaporate.
- (4) Before refinishing the blades, apply a corrosion preventive coating to the bare aluminum surface.
 - (a) Tasdip AL 100, Chromicote L-25, or Alodine 1201 are approved chemical conversion coatings.
 - (b) Apply these coatings in accordance with the directions provided by the product manufacturer.
- (5) Apply masking material for the anti-icing or de-ice boot and tip stripes, as needed.

WARNING: FINISH COATINGS ARE FLAMMABLE AND TOXIC TO THE SKIN. EYES AND RESPIRATORY TRACT. SKIN AND EYE PROTECTION ARE REQUIRED. AVOID PROLONGED CONTACT. USE IN WELL VENTILATED AREA.

CAUTION: APPLY FINISH COATING ONLY TO THE DEGREE REQUIRED TO UNIFORMLY COVER THE REPAIR/EROSION. AVOID EXCESSIVE PAINT BUILDUP ALONG THE TRAILING EDGE TO AVOID CHANGING BLADE PROFILE.

- (6) Apply sufficient finish coating to achieve 2 to 4 mils thickness when dry.
 - (a) Re-coat before 30 minutes, or after 48 hours.
 - (b) If the paint is permitted to dry longer than four (4) hours, it must be lightly sanded before another coat is applied.

- (7) Remove the masking material from the tip stripes and re-mask to allow for the tip stripe refinishing, if required.
- (8) Apply sufficient tip stripe coating to achieve 2 to 4 mils thickness when dry.
 - (a) Re-coat before 30 minutes, or after 48 hours.
 - (b) If the paint is permitted to dry longer than four (4) hours, it must be lightly sanded before another coat is applied.
- (9) Remove the masking material immediately from the de-ice boot and tip stripes, if required.
- (10) Optionally, perform dynamic balancing in accordance with the procedures and limitations specified in Dynamic Balance section of this chapter.

6. Dynamic Balance

A. Overview

CAUTION 1: INSTRUCTIONS AND PROCEDURES IN THIS SECTION MAY INVOLVE PROPELLER CRITICAL PARTS. REFER TO THE INTRODUCTION CHAPTER OF THIS MANUAL FOR INFORMATION ABOUT PROPELLER CRITICAL PARTS.

CAUTION 2: WHEN USING REFLECTIVE TAPE FOR DYNAMIC BALANCING, DO NOT APPLY THE TAPE ON EXPOSED BARE METAL OF A BLADE. THIS WILL PERMIT MOISTURE TO COLLECT UNDER THE TAPE AND CAUSE CORROSION THAT CAN PERMANENTLY DAMAGE THE BLADE. REFLECTIVE TAPE MUST BE REMOVED AFTER DYNAMIC BALANCING IS COMPLETED.

NOTE: Dynamic balance is recommended to reduce vibrations which may be caused by a rotating system (propeller and engine) imbalance. Dynamic balancing can help prolong the life of the propeller, engine, airframe, and avionics.

- (1) Dynamic balance is accomplished by using an accurate means of measuring the amount and location of the dynamic imbalance.
- (2) The number of balance weights installed must not exceed the limits specified in this chapter.
- (3) Follow the dynamic balance equipment manufacturer's instructions for dynamic balance in addition to the specifications of this section.

NOTE: Some engine manufacturer's instructions also contains information on dynamic balance limits.

- (4) Unless otherwise specified by the engine or airframe manufacturer, Hartzell Propeller Inc. recommends that the propeller be dynamically balanced to a reading of 0.2 IPS or less.

B. Inspection Procedures Before Balancing

- (1) Visually inspect the propeller assembly before dynamic balancing.

NOTE: The first run-up of a new or overhauled propeller assembly may leave a small amount of grease on the blades and inner surface of the spinner dome.

- (a) Using Stoddard solvent or equivalent, completely remove any grease on the blades or inner surface of the spinner dome.
 - (b) Visually check each propeller blade assembly for evidence of grease leakage.
 - (c) Visually inspect the inner surface of the spinner dome for evidence of grease leakage.
- (2) If there is no evidence of grease leakage, lubricate the propeller in accordance with the Maintenance Practices chapter in this manual. If grease leakage is evident, determine the location of the leak and correct before re-lubricating the propeller and dynamic balancing.
 - (3) Before dynamic balance record the number and location of all static balance weights.

- (4) Static balance is required when an overhaul or major repair is performed at a certified propeller repair station with the appropriate rating.

NOTE: If static balancing is not accomplished before dynamic balancing, the propeller may be so severely unbalanced that dynamic balance may not be achievable due to limitations of measurement equipment.

C. Placement of Balance Weights for Dynamic Balance

The preferred method of attachment of dynamic balance weights is to add the weights to the spinner bulkhead; however, the configuration of the spinner bulkhead on propeller models covered in this manual may make it impractical to mount dynamic balance weights in this manner. Dynamic balance must then be accomplished through the removal or addition and/or the relocation of the static balance weights located on the blade clamps.

- (1) Each blade clamp has four balance weight locations on the outboard circular surface of the clamp. Refer to Figure 6-4.
- (2) The maximum number of balance weights per location is four (4).

NOTE: For propellers with a de-ice system using a blade clamp-mounted terminal block, a maximum of three weights may be attached to the de-ice terminal block mounted on the blade clamp.

CAUTION 1: BEFORE DYNAMIC BALANCE, RECORD THE NUMBER AND LOCATION OF ALL STATIC BALANCE WEIGHTS.

CAUTION 2: USE ONLY STEEL BALANCE WEIGHTS A-1305.

CAUTION 3: DO NOT EXCEED THE MAXIMUM NUMBER OF BALANCE WEIGHTS PER LOCATION.

- (3) Alter the number and/or location of static balance weights as necessary to achieve dynamic balance.

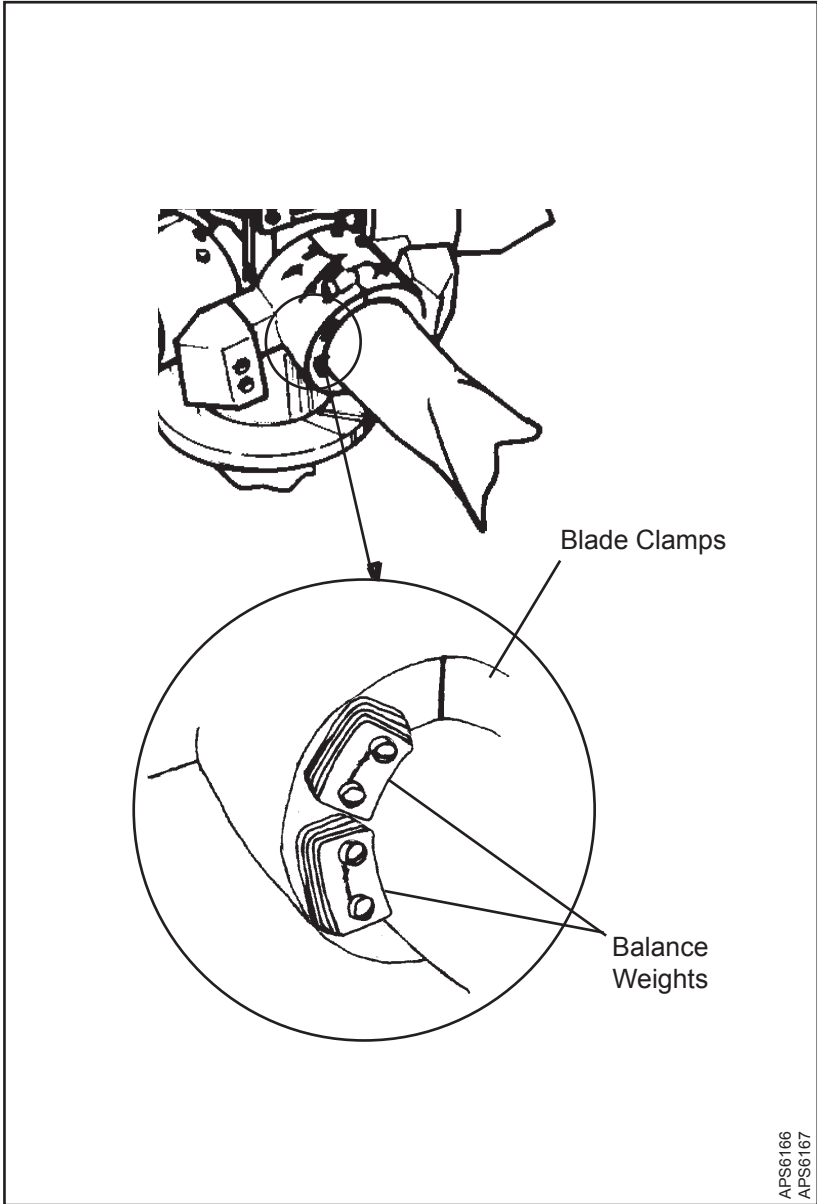

APS6166
APS6167

Location of Balance Weights
Figure 6-4

- (4) If reflective tape is used for dynamic balancing, remove the tape immediately upon completion of dynamic balancing.
- (5) Make a record of the number and location of static balance weights, if they have been reconfigured, in the propeller logbook.

7. Propeller Low Pitch Setting

WARNING 1: RPM ADJUSTMENTS MUST BE MADE WITH REFERENCE TO A CALIBRATED TACHOMETER. AIRCRAFT MECHANICAL TACHOMETERS DEVELOP ERRORS OVER TIME, AND SHOULD BE PERIODICALLY RECALIBRATED TO MAKE SURE THE PROPER RPM IS DISPLAYED.

WARNING 2: LOW PITCH BLADE ANGLE ADJUSTMENTS MUST BE MADE IN CONSULTATION WITH THE APPLICABLE TYPE CERTIFICATE OR SUPPLEMENTAL TYPE CERTIFICATE HOLDERS APPROVED MAINTENANCE DATA.

CAUTION: INSTRUCTIONS AND PROCEDURES IN THIS SECTION MAY INVOLVE PROPELLER CRITICAL PARTS. REFER TO THE INTRODUCTION CHAPTER OF THIS MANUAL FOR INFORMATION ABOUT PROPELLER CRITICAL PARTS.

A. Low Pitch Stop - All Propeller Models

- (1) The propeller low pitch stop is set at the factory to the aircraft TC or STC Holder's requirements and should not require any additional adjustment.
- (2) The TC or STC Holder provides the required low pitch stop blade angle and may also provide the acceptable RPM range for a maximum power static condition.
- (3) Be aware that the aircraft TC or STC holder may specify the static RPM to be less than the RPM to which the engine is rated.

- B. Low pitch measurement on propeller models
HC-9() () -2() ():

CAUTION: PUT A PAN UNDER THE PROPELLER PISTON BEFORE REMOVING THE NUT AND MOVING THE PISTON, AS ENGINE OIL MAY COME OUT OF THE OPENING IN THE PISTON.

- (1) Untorque and remove the piston nut from the pitch change rod.
- (2) Rotate the blades by hand to move the blades and piston to low pitch.

NOTE: Low pitch is reached when a washer on the end of each piston guide rod stops against the guide collar.

- (3) With the blade in a horizontal position, measure low pitch blade angle.
- (4) If the blade angle requires adjustment, have the low pitch stop adjusted by a certified propeller repair station with the appropriate rating or by the Hartzell Propeller Inc. factory.

- C. Low pitch measurement on propeller models
(B)HC-9() () -1() () and HC-92() () -8():

- (1) Rotate the blades by hand to move the blades and piston to low pitch.

NOTE: Low pitch is reached when a washer on the end of each piston guide rod stops against the guide collar.

- (2) With the blade in a horizontal position, measure the low pitch blade angle.
- (3) If the blade angle requires adjustment, have the low pitch stop adjusted by a certified propeller repair station with the appropriate rating.

- D. Low pitch measurement on propeller models HC-92()(-)3() and HC-92WF-5A.

CAUTION: PUT A PAN UNDER THE PROPELLER PISTON BEFORE REMOVING THE NUT AND MOVING THE PISTON, AS ENGINE OIL MAY COME OUT OF THE OPENING IN THE PISTON.

- (1) Remove the piston nut from the pitch change rod.
- (2) Rotate the blades by hand to move the blades and piston to low pitch. Refer to Figure 6-5.

NOTE: Low pitch is reached when the piston ears contact the self-locking nut on each rod, and when distance "C" is zero.

- (3) With the blade in a horizontal position, measure low pitch blade angle.
- (4) If the blade angle requires adjustment, refer to Adjusting Low Pitch Angle - Propeller Models BHC-92()f-3()() and HC-92WF-5A in this chapter.

- E. Adjusting Low Pitch Angle - Propeller Models BHC-92()f-3()() and HC-92WF-5A

WARNING 1: LOW PITCH BLADE ANGLE ADJUSTMENTS MUST BE MADE IN CONSULTATION WITH THE APPLICABLE TYPE CERTIFICATE OR SUPPLEMENTAL TYPE CERTIFICATE HOLDER'S MAINTENANCE DATA.

WARNING 2: ADJUSTMENT OF THE LOW PITCH STOP TO ACHIEVE THE SPECIFIED STATIC RPM MAY MASK AN ENGINE POWER PROBLEM.

- (1) Refer to the following procedure for accomplishing an adjustment to the low pitch angle. Refer to Figure 6-5.
 - (a) The low pitch adjustment "C" has been made at the factory according to published information. The readjustment of low pitch should not be required, although it is accomplished by adjusting the four nuts at the outer ends of the rods as shown in Figure 6-5, if the maximum engine/propeller RPM is incorrect.

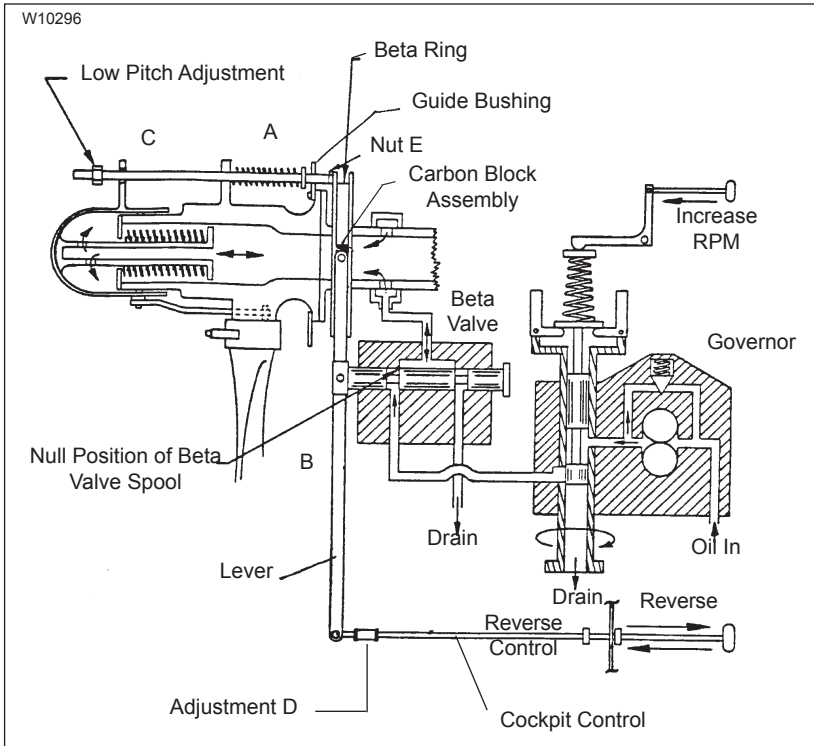

Adjusting Low Pitch Angle
Figure 6-5

(b) To check the maximum engine/propeller RPM, start the engine and check the RPM for full throttle operation. The RPM should correspond to rated engine RPM. The governor must be set for maximum RPM for this test.

- 1 If the RPM is too low, back the four low pitch adjustment nuts **out** approximately 3/4 of a turn (3/4 of a turn equals approximately 100 RPM increase). If this process does not increase the RPM, this means that the governor is limiting the RPM by calling for increased pitch. In this case, the governor must be adjusted to provide for higher RPM (increased compression on the speeder spring).

CAUTION: TO PREVENT THE RPM FROM EXCEEDING THE ENGINE RATING, TURN THE LOW PITCH ADJUSTMENT NUTS **IN** APPROXIMATELY 3/4 OF A TURN TO OBTAIN A 100 RPM REDUCTION.

- 2 An alternative method for determining whether the low pitch adjustment is limiting the RPM is to observe the movement of the beta valve spool during maximum power. "B" will increase from 1/16 inch (1.6 mm) to 3/16 inch (4.8 mm) during run-up of the engine for proper adjustment of the governor.
- (c) Check the runout of the beta ring by installing a dial indicator on the nose of the engine, so that it touches the rear face of the beta ring. If necessary, loosen nut "E" and rotate the rods to bring the runout to within 0.010 total indicator reading.
- (d) Torque nut "E" to 10-15 Ft-Lb (14-20 N•m).

(e) Make sure the four low pitch adjusting nuts contact the piston bosses at the same time the piston is moved toward reverse pitch. To accomplish this:

- 1 Equalize "C" for all four rods by means of accurate measurements.
- 2 Adjust the nuts if necessary. This will make sure that the slip ring runs true during pitch reversal.

8. High Pitch (Minimum RPM) Stop - Propeller models HC-9() ()-1() () , HC-92() ()-3() () , and HC-92() ()-8()

A. The high pitch stop is set at the factory per the aircraft manufacturer's recommendations. These stops are adjustable only by a certified propeller repair station with the appropriate rating or the Hartzell Propeller Inc. factory.

9. Feathering Pitch Stop Adjustment - Propeller Models HC-9() ()-2() () and HC-92WF-5A

A. The feathering pitch stop is set at the factory in accordance with the aircraft manufacturer's recommendations. This stop is adjustable only by a certified propeller repair station with the appropriate rating, aircraft manufacturer, or the Hartzell Propeller Inc. factory.

10. Start Lock Adjustment - Propeller models HC-9() ()-2() () and HC-92WF-5A

A. The start locks are set at the factory per the aircraft manufacturer's recommendations. Start locks are adjustable only by a certified propeller repair station with the appropriate rating, aircraft manufacturer, or the Hartzell Propeller Inc. factory.

11. Propeller Ice Protection Systems

A. Refer to the Anti-ice and De-ice Systems chapter of this manual for de-ice system maintenance information.