

Manual No. 168

61-00-68

Revision 5

August 2015

Propeller Owner's Manual and Logbook

Steel Hub Reciprocating Propellers with Aluminum Blades

Two Blade	Three Blade
(B)HC-A2(MV,V)(F,K,L)-1()	(E,P)HC-A3(MV,V)F-2()
HC-A2(MV,V)(F,K,L)-2()	HC-A3(MV,V)K-2() ()
BHC-A2(MV,V)F-3	HC-A3(MV,V)F-3L
HC-A2(MV,V)L-6F	(E,P)HC-A3(MV,V)(F,K)-4()
HA-A2(MV,V)20-1B	HC-A3(MV,V)F-5A()
HC-A2(MV,V)20-1A	(P)HC-A3(MV,V)F-5R
HC-A2(MV,V)20-2	HC-A3(MV,V)20-1()
HC-A2(MV,V)20-3L	HC-A3(MV,V)20-2()
	HC-A3(MV,V)20-3L

Hartzell Propeller Inc.

One Propeller Place

Piqua, OH 45356-2634 U.S.A.

Ph: 937-778-4200 (Hartzell Propeller Inc.)

Ph: 937-778-4379 (Product Support)

Product Support Fax: 937-778-4391

As a fellow pilot, I urge you to read this Manual thoroughly. It contains a wealth of information about your new propeller.

The propeller is among the most reliable components of your airplane. It is also among the most critical to flight safety. It therefore deserves the care and maintenance called for in this Manual. Please give it your attention, especially the section dealing with Inspections and Checks.

Thank you for choosing a Hartzell propeller. Properly maintained it will give you many years of reliable service.

A handwritten signature in black ink that reads "Jim Brown". The signature is fluid and cursive, with a long horizontal stroke extending to the right.

Jim Brown
Chairman, Hartzell Propeller Inc.

WARNING

People who fly should recognize that various types of risks are involved; and they should take all precautions to minimize them, since they cannot be eliminated entirely. The propeller is a vital component of the aircraft. A mechanical failure of the propeller could cause a forced landing or create vibrations sufficiently severe to damage the aircraft, possibly causing it to become uncontrollable.

Propellers are subject to constant vibration stresses from the engine and airstream, which are added to high bending and centrifugal stresses.

Before a propeller is certified as being safe to operate on an airplane, an adequate margin of safety must be demonstrated. Even though every precaution is taken in the design and manufacture of a propeller, history has revealed rare instances of failures, particularly of the fatigue type.

It is essential that the propeller is properly maintained according to the recommended service procedures and a close watch is exercised to detect impending problems before they become serious. Any grease or oil leakage, loss of air pressure, unusual vibration, or unusual operation should be investigated and repaired, as it could be a warning that something serious is wrong.

For operators of uncertified or experimental aircraft an even greater level of vigilance is required in the maintenance and inspection of the propeller. Experimental installations often use propeller-engine combinations that have not been tested and approved. In these cases, the stress on the propeller and, therefore, its safety margin is unknown. Failure could be as severe as loss of propeller or propeller blades and cause loss of propeller control and/or loss of aircraft control.

Hartzell Propeller Inc. follows FAA regulations for propeller certification on certificated aircraft. Experimental aircraft may operate with unapproved engines or propellers or engine modifications to increase horsepower, such as unapproved crankshaft damper configurations or high compression pistons. These issues affect the vibration output of the engine and the stress levels on the propeller. Significant propeller life reduction and failure are real possibilities.

Frequent inspections are strongly recommended if operating with a non-certificated installation; however, these inspections may not guarantee propeller reliability, as a failing device may be hidden from the view of the inspector. Propeller overhaul is strongly recommended to accomplish periodic internal inspection.

Visually inspect metal blades for cracks. Inspect hubs, with particular emphasis on each blade arm for cracks. Eddy current equipment is recommended for hub inspection, since cracks are usually not apparent.

(This page is intentionally blank.)

REVISION HIGHLIGHTS

Revision 5, dated August 2015, incorporates the following:

- Revised Cover, [Revision Highlights](#), [List of Effective Pages](#), and [Table of Contents](#) to reflect changes.
- [Revised the Service Documents List.](#)
- Introduction Chapter
 - [Revised the Reference Publications section.](#)
 - [Revised the Maintenance Practices section to include alternate use of safety cable.](#)
- Installation and Removal Chapter
 - [Revised the Tools, Consumables, and Expendables section.](#)
 - [Revised Table 3-1.](#)
 - [Revised Table 3-2.](#)
 - [Revised to allow equivalent aircraft safety cable and associated hardware in place of safety wire for mounting bolts.](#)
 - [Revised feathering spring assembly removal instructions.](#)
 - [Revised Post-Installation Checks section](#)
- Maintenance Practices Chapter
 - [Revised the Caution about using a pneumatic grease gun to lubricate the propeller.](#)

(This page is intentionally blank.)

REVISIONS HIGHLIGHTS**1. Introduction****A. General**

This is a list of current revisions that have been issued against this manual. Please compare it to the RECORD OF REVISIONS page to ensure that all revisions have been added to the manual.

B. Components

- (1) Revision No. indicates the revisions incorporated in this manual.
- (2) Issue Date is the date of the revision.
- (3) Comments indicates the level of the revision.
 - (a) New Issue is a new manual distribution. The manual is distributed in its entirety. All the page revision dates are the same and no change bars are used.
 - (b) Reissue is a revision to an existing manual that includes major content and/or major format changes. The manual is distributed in its entirety. All the page revision dates are the same and no change bars are used.
 - (c) Major Revision is a revision to an existing manual that includes major content or minor content changes over a large portion of the manual. The manual is distributed in its entirety. All the page revision dates are the same, but change bars are used to indicate the changes incorporated in the latest revision of the manual.
 - (d) Minor Revision is a revision to an existing manual that includes minor content changes to the manual. Only the revised pages of the manual are distributed. Each page retains the date and the change bars associated with the last revision to that page.

<u>Revision No.</u>	<u>Issue Date</u>	<u>Comments</u>
Original	July/01	New Issue
Rev. 1	Oct/04	Minor Revision
Rev. 2	July/08	Minor Revision
Rev. 3	Mar/11	Minor Revision
Rev. 4	Oct/13	Minor Revision
Rev. 5	Aug/15	Minor Revision

RECORD OF REVISIONS

Rev. No.	Issue Date	Date Inserted	Inserted By
Rev. 1	Oct/04	Oct/04	HPI
Rev. 2	July/08	July/08	HPI
Rev. 3	Mar/11	Mar/11	HPI
Rev. 4	Oct/13	Oct/13	HPI
Rev. 5	Aug/15	Aug/15	HPI

RECORD OF REVISIONS

Rev. No. Issue Date Date Inserted Inserted By

Rev. No.	Issue Date	Date Inserted	Inserted By

RECORD OF TEMPORARY REVISIONS

TR No.	Issue Date	Date Inserted	Inserted By	Date Removed	Removed By
TR-001	Nov/03	Nov/03	HPI	Oct/04	HPI
TR-002	Dec/03	Dec/03	HPI	Oct/04	HPI
TR-003	May/04	May/04	HPI	Oct/04	HPI

RECORD OF TEMPORARY REVISIONS

SERVICE DOCUMENTS LIST

CAUTION 1: DO NOT USE OBSOLETE OR OUTDATED INFORMATION. PERFORM ALL INSPECTIONS OR WORK IN ACCORDANCE WITH THE MOST RECENT REVISION OF THE SERVICE DOCUMENT. INFORMATION CONTAINED IN A SERVICE DOCUMENT MAY BE SIGNIFICANTLY CHANGED FROM EARLIER REVISIONS. USE OF OBSOLETE INFORMATION MAY CREATE AN UNSAFE CONDITION THAT MAY RESULT IN DEATH, SERIOUS BODILY INJURY, AND/OR SUBSTANTIAL PROPERTY DAMAGE. REFER TO THE APPLICABLE SERVICE DOCUMENT INDEX FOR THE MOST RECENT REVISION LEVEL OF THE SERVICE DOCUMENT.

CAUTION 2: THE INFORMATION FOR THE DOCUMENTS LISTED INDICATES THE REVISION LEVEL AND DATE AT THE TIME THAT THE DOCUMENT WAS INITIALLY INCORPORATED INTO THIS MANUAL. INFORMATION CONTAINED IN A SERVICE DOCUMENT MAY BE SIGNIFICANTLY CHANGED FROM EARLIER REVISIONS. REFER TO THE APPLICABLE SERVICE DOCUMENT INDEX FOR THE MOST RECENT REVISION LEVEL OF THE SERVICE DOCUMENT.

Service Document Number	Incorporation Rev/Date
HC-SL-61-176	Original, Jul/01
HC-SL-61-324	Rev. 4, Oct/13
HC-SL-61-256	Rev. 5, Aug/15

AIRWORTHINESS LIMITATIONS

The Airworthiness Limitations section is FAA approved and specifies maintenance required under 14 CFR §§ 43.16 and 91.403 of the Federal Aviation Regulations unless an alternative program has been FAA approved.

FAA APPROVED

by: Michael Deane date: 3/15/11

A Manager, Chicago Aircraft Certification
Office,
ACE-115C
Federal Aviation Administration

Rev. No.	Description of Revision

AIRWORTHINESS LIMITATIONS

1. The FAA establishes specific life limits for certain component parts as well as the entire propeller. Such limits require replacement of the identified parts after a specified number of hours of use.
2. The following data summarizes all current information concerning Hartzell life limited parts as related to propeller models affected by this manual. These parts are not life limited on other installations; however, time accumulated toward life limit accrues when first operated on aircraft/engine/propeller combinations listed and continues regardless of subsequent installations (that may or may not be life limited).
 - A. Propeller models affected by this manual currently do not have any life limited parts.
 - B. There are no new (or additional) Airworthiness Limitations associated with this equipment and/or installation.

FAA APPROVED

by: Michael D. Dore

date: 3/15/11

for Manager, Chicago Aircraft Certification
Office,
ACE-115C
Federal Aviation Administration

LIST OF EFFECTIVE PAGES

Chapter	Page	Revision	Date
Cover	Cover and Inside Cover	Rev. 5	Aug/15
Message	1 thru 4	Original	July/01
Revision Highlights	5 thru 8	Rev. 5	Aug/15
Record of Revisions	9 and 10	Original	July/01
Record of Temporary Revisions	11 and 12	Original	July/01
Service Documents List	13 and 14	Rev. 5	Aug/15
Airworthiness Limitations	15 and 16	Rev. 3	Mar/11
List of Effective Pages	17 thru 20.2	Rev. 5	Aug/15
Table of Contents	21 thru 23	Rev. 3	Mar/11
Table of Contents	24	Rev. 5	Aug/15
Table of Contents	25 and 26	Rev. 4	Oct/13
Table of Contents	27 thru 34	Rev. 3	Mar/11
Introduction	1-1 thru 1-5	Rev. 4	Oct/13
Introduction	1-6	Rev. 5	Aug/15
Introduction	1-7	Rev. 4	Oct/13
Introduction	1-8	Rev. 5	Aug/15
Introduction	1-9 thru 1-16	Rev. 4	Oct/13
Description and Operation	2-1	Rev. 2	July/08
Description and Operation	2-2 thru 2-36	Original	July/01
Description and Operation	2-37	Rev. 1	Oct/04
Description and Operation	2-38 thru 2-44	Original	July/01
Description and Operation	2-45	Rev. 2	July/08
Description and Operation	2-46	Original	July/01
Installation and Removal	3-1	Rev. 4	Oct/13
Installation and Removal	3-2 and 3-3	Rev. 5	Aug/15
Installation and Removal	3-4	Original	July/01
Installation and Removal	3-5	Rev. 2	July/08
Installation and Removal	3-6	Original	July/01
Installation and Removal	3-7 and 3-8	Rev. 5	Aug/15
Installation and Removal	3-9 and 3-10	Original	July/01

LIST OF EFFECTIVE PAGES

Chapter	Page	Revision	Date
■ Installation and Removal	3-11	Rev. 5	Aug/15
Installation and Removal	3-12	Rev. 3	Mar/11
Installation and Removal	3-13 and 3-14	Original	July/01
Installation and Removal	3-15	Rev. 2	July/08
Installation and Removal	3-16	Rev. 4	Oct/13
Installation and Removal	3-16.1 and 3-16.2	Rev. 4	Oct/13
Installation and Removal	3-17 and 3-18	Original	July/01
Installation and Removal	3-19 and 3-20	Rev. 4	Oct/13
Installation and Removal	3-21	Rev. 2	July/08
■ Installation and Removal	3-22 and 3-23	Rev. 5	Aug/15
Installation and Removal	3-24 and 3-25	Rev. 2	July/08
Installation and Removal	3-26	Original	July/01
Installation and Removal	3-27 thru 3-29	Rev. 4	Oct/13
■ Installation and Removal	3-30	Rev. 5	Aug/15
Installation and Removal	3-31 and 3-32	Original	July/01
Installation and Removal	3-33	Rev. 4	Oct/13
Installation and Removal	3-34	Original	July/01
■ Installation and Removal	3-35	Rev. 4	Oct/13
Installation and Removal	3-36	Rev. 5	Aug/15
■ Installation and Removal	3-37	Rev. 4	Oct/13
Installation and Removal	3-38	Original	July/01
Installation and Removal	3-39	Rev. 2	July/08
Installation and Removal	3-40 and 3-41	Rev. 4	Oct/13
■ Installation and Removal	3-42 and 3-43	Rev. 5	Aug/15
Installation and Removal	3-44	Original	July/01
Installation and Removal	3-45 and 3-46	Rev. 4	Oct/13
Installation and Removal	3-46.1 and 3-46.2	Rev. 4	Oct/13
Installation and Removal	3-47	Rev. 4	Oct/13
■ Installation and Removal	3-48	Rev. 5	Aug/15
Installation and Removal	3-49	Rev. 2	July/08
Installation and Removal	3-50	Rev. 3	Mar/11

LIST OF EFFECTIVE PAGES

Chapter	Page	Revision	Date
Installation and Removal	3-51 thru 3-54	Rev. 4	Oct/13
Installation and Removal	3-54.1	Rev. 5	Aug/15
Installation and Removal	3-54.2	Rev. 4	Oct/13
Installation and Removal	3-55	Rev. 4	Oct/13
Installation and Removal	3-56	Original	July/01
Installation and Removal	3-57 thru 3-59	Rev. 4	Oct/13
Installation and Removal	3-60 and 3-61	Rev. 5	Aug/15
Installation and Removal	3-62	Original	July/01
Installation and Removal	3-63 and 3-64	Rev. 4	Oct/13
Installation and Removal	3-65 and 3-66	Rev. 5	Aug/15
Installation and Removal	3-67	Original	July/01
Installation and Removal	3-68 thru 3-74	Rev. 2	July/08
Installation and Removal	3-75 and 3-76	Rev. 4	Oct/13
Installation and Removal	3-77 and 3-78	Rev. 2	July/08
Installation and Removal	3-79	Rev. 5	Aug/15
Installation and Removal	3-80 thru 3-86	Rev. 2	July/08
Installation and Removal	3-87 and 3-88	Rev. 4	Oct/13
Installation and Removal	3-89	Rev. 5	Aug/15
Installation and Removal	3-90	Rev. 2	July/08
Installation and Removal	3-91 and 3-92	Rev. 4	Oct/13
Installation and Removal	3-93	Rev. 5	Aug/15
Installation and Removal	3-94 thru 3-96	Rev. 2	July/08
Installation and Removal	3-97	Rev. 4	Oct/13
Installation and Removal	3-98	Rev. 5	Aug/15
Installation and Removal	3-99 and 3-100	Rev. 2	July/08
Installation and Removal	3-101 and 3-102	Rev. 4	Oct/13
Installation and Removal	3-103	Rev. 2	July/08
Installation and Removal	3-104	Rev. 5	Aug/15
Installation and Removal	3-105 thru 3-110	Rev. 2	July/08
Installation and Removal	3-111	Rev. 4	Oct/13
Installation and Removal	3-112 thru 3-115	Rev. 2	July/08

LIST OF EFFECTIVE PAGES

Chapter	Page	Revision	Date
Installation and Removal	3-116 and 3-117	Rev. 3	Mar/11
Installation and Removal	3-118	Rev. 2	July/08
Installation and Removal	3-119 thru 3-122	Rev. 4	Oct/13
Installation and Removal	3-123 and 3-124	Rev. 2	July/08
Installation and Removal	3-125 thru 3-130	Rev. 4	Oct/13
Installation and Removal	3-131 and 3-132	Rev. 2	July/08
Installation and Removal	3-133	Rev. 4	Oct/13
Installation and Removal	3-134 thru 3-137	Rev. 5	Aug/15
Installation and Removal	3-138 thru 3-142	Rev. 2	July/08
Installation and Removal	3-143	Rev. 4	Oct/13
Installation and Removal	3-144 thru 3-150	Rev. 5	Aug/15
Installation and Removal	3-151 thru 3-160	Rev. 4	Oct/13
Installation and Removal	3-161 and 3-162	Rev. 2	July/08
Installation and Removal	3-163 and 3-164	Rev. 4	Oct/13
Installation and Removal	3-165 and 3-166	Rev. 2	July/08
Installation and Removal	3-167 thru 3-175	Rev. 4	Oct/13
Installation and Removal	3-176 and 3-177	Rev. 2	July/08
Installation and Removal	3-178 thru 3-185	Rev. 4	Oct/13
Installation and Removal	3-186	Rev. 2	July/08
Installation and Removal	3-187	Rev. 4	Oct/13
Installation and Removal	3-188 thru 3-190	Rev. 2	July/08
Installation and Removal	3-191 thru 3-201	Rev. 4	Oct/13
Installation and Removal	3-202 thru 3-206	Rev. 5	Aug/15
Installation and Removal	3-207 and 3-208	Rev. 4	Oct/13
Testing and Troubleshooting	4-1 thru 4-16	Rev. 4	Oct/13
Inspection and Check	5-1 and 5-2	Rev. 2	July/08
Inspection and Check	5-3 thru 5-7	Rev. 4	Oct/13
Inspection and Check	5-8	Rev. 1	Oct/04
Inspection and Check	5-9 and 5-10	Rev. 4	Oct/13
Inspection and Check	5-11 and 5-12	Original	July/01
Inspection and Check	5-13	Rev. 4	Oct/13

LIST OF EFFECTIVE PAGES

Chapter	Page	Revision	Date
Inspection and Check	5-14	Original	July/01
Inspection and Check	5-15 and 5-16	Rev. 4	Oct/13
Inspection and Check	5-17	Rev. 1	Oct/04
Inspection and Check	5-18 thru 5-21	Rev. 4	Oct/13
Inspection and Check	5-22 and 5-23	Rev. 2	July/08
Inspection and Check	5-24	Rev. 4	Oct/13
Maintenance Practices	6-1	Rev. 2	July/08
Maintenance Practices	6-2	Rev. 3	Mar/11
Maintenance Practices	6-3 and 6-4	Original	July/01
Maintenance Practices	6-5 and 6-6	Rev. 4	Oct/13
Maintenance Practices	6-7	Rev. 5	Aug/15
Maintenance Practices	6-8	Rev. 2	July/08
Maintenance Practices	6-9 and 6-10	Rev. 4	Oct/13
Maintenance Practices	6-11 and 6-12	Original	July/01
Maintenance Practices	6-13 thru 6-16	Rev. 4	Oct/13
Maintenance Practices	6-17 and 6-18	Rev. 3	Mar/11
Maintenance Practices	6-19 and 6-20	Rev. 4	Oct/13
Maintenance Practices	6-21 thru 6-25	Rev. 3	Mar/11
Maintenance Practices	6-26 and 6-27	Rev. 4	Oct/13
Maintenance Practices	6-28 thru 6-32	Rev. 2	July/08
Anti-Ice and De-Ice Systems	7-1 thru 7-3	Rev. 2	July/08
Anti-Ice and De-Ice Systems	7-4	Original	July/01
Anti-Ice and De-Ice Systems	7-5 thru 7-8	Rev. 2	July/08
Records	8-1 thru 8-4	Original	July/01

LIST OF EFFECTIVE PAGES

Chapter	Page	Revision	Date
---------	------	----------	------

TABLE OF CONTENTS

Page

MESSAGE.....	1
REVISION HIGHLIGHTS	5
RECORD OF REVISIONS	9
RECORD OF TEMPORARY REVISIONS.....	11
SERVICE DOCUMENTS LIST	13
AIRWORTHINESS LIMITATIONS	15
LIST OF EFFECTIVE PAGES	17
TABLE OF CONTENTS.....	21
INTRODUCTION	1-1
1. Purpose.....	1-3
2. Airworthiness Limits	1-3
3. Airframe or Engine Modifications	1-3
4. Restrictions and Placards.....	1-4
5. General	1-4
A. Personnel Requirements.....	1-4
B. Maintenance Practices	1-4
C. Continued Airworthiness	1-6
6. Reference Publications	1-6
7. Definitions	1-9
8. Abbreviations	1-12
9. Hartzell Product Support.....	1-13
10. Warranty Service	1-13
11. Hartzell Recommended Facilities	1-13

TABLE OF CONTENTS

Page

DESCRIPTION AND OPERATION	2-1
1. Description of Propeller and Systems	2-3
A. Ground Adjustable Pitch Propellers	2-7
B. Constant Speed, Non-counterweighted, Nonfeathering Propellers	2-9
C. Constant Speed, Counterweighted, Nonfeathering Propellers	2-13
D. Constant Speed and Feathering Propellers	2-17
E. Constant Speed, Feathering and Reversing Propellers (External Beta System)	2-21
F. Constant Speed and Reversing Propellers (External Beta System)	2-27
G. Constant Speed, Feathering and Reversing Propellers (Internal Beta System)	2-31
2. Model Designation	2-34
A. Steel Hub Propeller Model Identification	2-34
B. Aluminum Blade Model Identification	2-37
C. Conversion From V Shank to MV Shank	2-38
3. Governors	2-41
A. Theory of Operation	2-41
B. Governor Types	2-44
C. Identification of Hartzell Governors	2-44
4. Propeller Ice Protection Systems	2-45
A. Propeller Anti-Ice System	2-45
B. Propeller De-Ice System	2-46
INSTALLATION AND REMOVAL	3-1
1. Tools, Consumables, and Expendables	3-7
A. Tooling	3-7
B. Consumables	3-8
C. Expendables	3-8
2. O-ring and Propeller Mounting Hardware Identification	3-10

TABLE OF CONTENTS

Page

3. Pre-Installation	3-15
A. Inspection of Shipping Package	3-15
B. Uncrating	3-15
C. Inspection after Shipment	3-15
D. Reassembly of a Propeller Disassembled for Shipment ..	3-15
4. Propeller Assembly Installation	3-16
A. Precautions	3-16
B. O-ring and Propeller Mounting Hardware Identification ...	3-16
C. Installing F Flange Propeller Models (B)HC-A2(MV,V)F-1()	3-19
D. Installing K and L Flange Propeller Models HC-A2(MV,V)(K,L)-1() and HC-A2(MV,V)L-6F	3-27
E. Installing F Flange Propeller Models HC-A2(MV,V)F-2()	3-33
F. Installing K and L Flange Propeller Models HC-A2(MV,V)(K,L)-2	3-39
G. Installing F Flange Propeller Models (E,P)HC-A3(MV,V)F-2() except those using a spacer as specified in paragraph 4.H.....	3-45
H. Installing the EHC-A3(MV,V)F-2B Propeller using a spacer as installed on, but not limited to, the Beech 95-55, -A55, -B55, Colemill Baron Aircraft Engines, and Aero Commander Aircraft	3-51
I. Installing K Flange Propeller Models HC-A3(MV,V)K-2()().....	3-57
J. Installing F Flange Propeller Models BHC-A2(MV,V)F-3	3-63
K. Installing F Flange Propeller Models HC-A3(MV,V)F-3L	3-75
L. Installing F Flange Propeller Models (E,P)HC-A3(MV,V)F-4()	3-87
M. Installing K Flange Propeller Models HC-A3(MV,V)K-4	3-91

TABLE OF CONTENTS

Page

N.	Installing F Flange Propeller Models HC-A3(MV,V)F-5A(L)	3-97
O.	Installing F Flange Propeller Models (P)HC-A3(MV,V)F-5R	3-101
P.	Installing Splined Propeller Models HA-A2(MV,V)20-1B	3-111
Q.	Installing the 20 Spline Propeller Models HC-A2(MV,V)20-1A.....	3-119
R.	Installing Splined Propeller Models HC-A3(MV,V)20-1()	3-125
S.	Installing Splined Propeller Models HC-A2(MV,V)20-2 and HC-A3(MV,V)20-2()	3-133
T.	Installing the 20 Splined Propeller Models HC-A2(MV,V)20-3L and HC-A3(MV,V)20-3L.....	3-143
■ 5.	Post-Installation Checks.....	3-150
6.	Propeller Assembly Removal	3-151
A.	Removing the F Flange Propeller Models (B)HC-A2(MV,V)F-1()	3-151
B.	Removing the K and L Flange Propeller Models HC-A2(MV,V)(K,L)-1() and HC-A2(MV,V)L-6F.....	3-153
C.	Removing the F Flange Propeller Models HC-A2(MV,V)F-2()	3-156
D.	Removing the K and L Flange Propeller Models HC-A2(MV,V)(K,L)-2().....	3-159
E.	Removing the F Flange Propeller Models (E,P)HC-A3(MV,V)F-2() except those using a spacer as specified in paragraph 6.F.....	3-163
F.	Removing the EHC-A3(MV,V)F-2B Propeller using a spacer as installed on, but not limited to, the Beech 95-55, -A55, -B55, Colemill Baron Aircraft Engines, and Aero Commander Aircraft	3-167
G.	Removing the K Flange Propeller Models HC-A3(MV,V)K-2().....	3-169

<u>TABLE OF CONTENTS</u>		<u>Page</u>
H.	Removing the F Flange Propeller Models BHC-A2(MV,V)F-3	3-172
I.	Removing F Flange Propeller Models HC-A3(MV,V)F-3L	3-175
J.	Removing F Flange Propeller Models (E,P)HC-A3(MV,V)F-4()	3-178
K.	Removing K Flange Propeller Models HC-A3(MV,V)K-4	3-181
L.	Removing F Flange Propeller Models HC-A3(MV,V)F-5A(L).....	3-184
M.	Removing F Flange Propeller Models (P)HC-A3(MV,V)F-5R	3-187
N.	Removing the 20 Splined Propeller Model HA-A2(MV,V)20-1B.....	3-191
O.	Removing the 20 Splined Propeller Models HC-A2(MV,V)20-1A	3-194
P.	Removing the 20 Splined Propeller Models HC-A3(MV,V)20-1()	3-197
Q.	Removing the 20 Splined Propeller Models HC-A2(MV,V)20-2 and HC-A3(MV,V)20-2()	3-200
R.	Removing the 20 Splined Propeller Models HC-A2(MV,V)20-3L and HC-A3(MV,V)20-3L	3-204
TESTING AND TROUBLESHOOTING		4-1
1.	Operational Tests	4-3
A.	Initial Run-Up	4-3
B.	Static RPM Check	4-4
C.	Post-Run Check	4-4
2.	Propeller Ice Protection Systems	4-5
A.	Electric De-Ice System	4-5
B.	Anti-Ice System	4-5
3.	Troubleshooting.....	4-5
A.	Incorrect Maximum RPM (on ground)	4-5
B.	Hunting and Surging	4-7

TABLE OF CONTENTS

Page

C. Engine Speed Varies with Airspeed	4-8
D. Loss of Propeller Control - ()HC-A3()()-4() and HC-A2(MV,V)L-6F propeller models:	4-9
E. Loss of propeller Control - ()HC-A()()()-1(), -2(), -3(), and -5() propeller models:	4-10
F. Failure to Feather or Feathers Slowly - ()HC-A()()()-2() and ()HC-A()()()-5() propeller models only:	4-11
G. Failure to Unfeather - ()HC-A()()()-2() and ()HC-A()()()-5() propeller models only:	4-11
H. Start Locks (Anti-Feather Latches) Fail to Engage on Shutdown - ()HC-A()()()-2, and -5 propeller models only:	4-12
I. Vibration	4-13
J. Propeller Overspeed	4-14
K. Propeller Underspeed	4-14
L. Oil or Grease Leakage	4-15

INSPECTION AND CHECK.....5-1

1. Pre-Flight Checks.....	5-3
2. Operational Checks.....	5-5
3. Required Periodic Inspections and Maintenance.....	5-6
A. Periodic Inspection	5-6
B. Periodic Maintenance.....	5-7
C. Airworthiness Limitations	5-7
D. Overhaul Periods	5-8
4. Inspection Procedures	5-9
A. Blade Damage	5-9
B. Grease or Oil Leakage	5-9
C. Vibration	5-11
D. Tachometer Inspection	5-13
E. Blade Track	5-15
F. Loose Blades	5-15

<u>TABLE OF CONTENTS</u>		<u>Page</u>
G.	Corrosion.....	5-16
H.	Spinner Damage	5-16
I.	Electric De-Ice System	5-16
J.	Anti-Ice System	5-16
5.	Special Inspections	5-19
A.	Overspeed.....	5-19
B.	Lightning Strike	5-20
C.	Foreign Object Strike/Ground Strike	5-22
D.	Fire Damage or Heat Damage	5-24
6.	Long Term Storage.....	5-24
	MAINTENANCE PRACTICES	6-1
1.	Cleaning.....	6-3
A.	General Cleaning	6-3
B.	Spinner Cleaning and Polishing	6-3
2.	Lubrication.....	6-5
A.	Lubrication Intervals	6-5
B.	Lubrication Procedure	6-5
C.	Approved Lubricants	6-8
3.	Carbon Block Assemblies	6-9
A.	Inspection	6-9
B.	Replacement of A-3026 Carbon Block Unit in the A-3044 Carbon Block Assembly	6-9
C.	Installation of the A-3044 Carbon Block Assembly.....	6-10
4.	Blade Repairs.....	6-13
A.	Repair of Nicks and Gouges	6-13
B.	Repair of Bent Blades	6-15
5.	Painting After Repair	6-16
A.	Painting of Aluminum Blades	6-17

TABLE OF CONTENTS

Page

6. Dynamic Balance	6-19
A. Overview	6-19
B. Inspection Procedures Before Balancing	6-19
C. Placement of Balance Weights for Dynamic Balance	6-24
7. Propeller Low Pitch Setting	6-26
A. Low Pitch Stop - All Propeller Models	6-26
B. Low pitch measurement on propeller models ()HC-A3()()-2():	6-26
C. Low pitch measurement on propeller models HC-A2()()-2() and ()HC-A()()()-5A(L)	6-27
D. Low pitch measurement on propeller models ()HC-A()()()-1(), ()HC-A()()()-4(), and ()HC-A()()()-6():	6-27
E. Low pitch measurement on propeller models BHC-A2()F-3(), HC-A3()F-3L, and ()HC-A3()F-5R:	6-28
F. Adjusting Low Pitch - Propeller models BHC-A2()F-3(), HC-A3()F-3L, and ()HC-A3()F-5R:	6-29
G. Setting Low Pitch Angle - Propeller Models HC-A()()(20)-3()	6-31
8. Propeller High Pitch Settings	6-31
A. High Pitch (Minimum RPM) Stop - Propeller Models ()HC-A()()()-1(), ()HC-A()()()-3(), ()HC-A()()()-4(), and ()HC-A()()()-6()	6-31
9. Feathering Pitch Stop Settings	6-31
A. Feathering Pitch Stop Adjustment - Propeller Models ()HC-A()()()-2() and ()HC-A()()()-5()	6-31
10. Start Lock Settings	6-32
A. Start Lock Adjustment - Propeller Models ()HC-A()()()-2() and ()HC-A()()()-5()	6-32
11. Propeller Ice Protection Systems	6-32

TABLE OF CONTENTS**Page**

ANTI-ICE AND DE-ICE SYSTEMS	7-1
1. Introduction	7-3
A. Propeller De-Ice System	7-3
B. Propeller Anti-Ice System	7-3
2. System Description	7-4
A. De-Ice System	7-4
B. Anti-Ice System	7-5
3. De-Ice System Functional Tests	7-5
4. Anti-Ice System Functional Tests	7-5
5. De-Ice and Anti-Ice System Inspections	7-6
A. De-Ice System Inspections	7-6
B. Anti-Ice System Inspections	7-6
6. De-Ice and Anti-Ice System Troubleshooting	7-6
A. De-Ice System Troubleshooting	7-6
B. Anti-Ice System Troubleshooting	7-7
RECORDS	8-1
1. Introduction	8-3
2. Record Keeping	8-3
A. Information to be Recorded	8-3

LIST OF FIGURES

Page

Steel Hub Unit (For Splined Shaft Mounting)	Figure 2-1	2-3
Spline Shaft Attachment	Figure 2-2	2-4
Flanged Attachment.....	Figure 2-3	2-5
Ground Adjustable Propeller Assembly	Figure 2-4	2-6
Constant Speed, Non-counterweighted, Nonfeathering Propeller Assembly.....	Figure 2-5	2-8
Constant Speed, Counterweighted, Nonfeathering Propeller Assembly.....	Figure 2-6	2-11
Constant Speed, Counterweighted, Nonfeathering Propeller Assembly.....	Figure 2-7	2-12
Constant Speed, Feathering Propeller Assembly.....	Figure 2-8	2-15
Constant Speed, Feathering Propeller Assembly.....	Figure 2-9	2-16
Constant Speed, Feathering and Reversing Propeller Assembly (External Beta System)	Figure 2-10	2-20
Fundamental Elements of a Reversing System	Figure 2-11	2-22
Constant Speed and Reversing Propeller Assembly (External Beta System)	Figure 2-12	2-26
Constant Speed Feathering and Reversing Propeller Assembly (Internal Beta System).....	Figure 2-13	2-30
Governor in Onspeed Condition	Figure 2-14	2-40
Governor in Underspeed Condition	Figure 2-15	2-40
Governor in Overspeed Condition	Figure 2-16	2-40
Feathering Governor	Figure 2-17	2-42
Synchronizer/Synchrophaser Governor.....	Figure 2-18	2-42

LIST OF FIGURESPage

(B)HC-A2(MV,V)(F,K,L)-1() Propeller Assembly	Figure 3-1	3-17
F Flange Installation on -1() Propeller Models	Figure 3-2	3-18
Installing F Flange Propeller on the Engine Flange	Figure 3-3	3-20
Determining Torque Value When Using Torquing Adapter	Figure 3-4	3-21
K and L Flange Installations on -1(), -4, and -6F Propeller Models	Figure 3-5	3-26
Installing K or L Flange Propeller on the Engine Flange	Figure 3-6	3-28
HC-A2(MV,V)(F,K,L)-2() Propeller Assembly	Figure 3-7	3-32
F Flange Installation on -2 Propeller Models	Figure 3-8	3-34
K and L Flange Installation on -2 Propeller Models	Figure 3-9	3-38
(E,P)HC-A3(MV,V)F-2()() Propeller Assembly	Figure 3-10	3-44
EHC-A3(MV,V)F-2B Mounting Parts	Figure 3-11	3-50
EHC-A3(MV,V)F-2B Installation	Figure 3-12	3-50
HC-A3(MV,V)K-2()() Propeller Assembly	Figure 3-13	3-56
BHC-A2(MV,V)F-3 Propeller Assembly	Figure 3-14	3-62
Tool for Decompressing External Beta System	Figure 3-15	3-63
Carbon Block and Beta Ring Clearance	Figure 3-16	3-66
Carbon Block Assembly	Figure 3-17	3-66

LIST OF FIGURES

Page

Installation of Beta Valve, Governor, and Linkage.....	Figure 3-18.....	3-67
Adjusting Propeller Reverse Control System	Figure 3-19.....	3-70
HC-A3(MV,V)F-3L Propeller Assembly.....	Figure 3-20.....	3-74
Tool for Decompressing External Beta System	Figure 3-21	3-75
HC-A3(MV,V)F-3L Installation	Figure 3-22.....	3-76
(E,P)HC-A3(MV,V)(F,K)-4() Propeller Assembly.....	Figure 3-23.....	3-86
HC-A3(MV,V)F-5A(L) Propeller Assembly.....	Figure 3-24.....	3-96
(P)HC-A3(MV,V)F-5R Propeller Assembly.....	Figure 3-25.....	3-100
(P)HC-A3(MV,V)F-5R Installation.....	Figure 3-26.....	3-101
HA-A2(MV,V)20-1B Propeller Assembly.....	Figure 3-27	3-110
Piston-to-Link Arm Attachment Details	Figure 3-28.....	3-111
Pitch Adjustment Assembly-to-Cylinder Attachment Details	Figure 3-29.....	3-112
Rear Hub Mounting Parts on HA-A2(MV,V)20-1B Propeller	Figure 3-30.....	3-114
Safetying the Shaft Nut on the 20 Spline Shaft Propeller.....	Figure 3-31	3-114
Installing Piston O-Ring and Felt Dust Seal	Figure 3-32.....	3-115
HC-A2(MV,V)20-1A Propeller Assembly.....	Figure 3-33.....	3-118
HC-A3(MV,V)20-1() Propeller Assembly.....	Figure 3-34.....	3-124

	<u>Page</u>
Rear Hub Mounting Parts on HC-A3(MV,V)20-1() Propeller.....	Figure 3-35..... 3-126
HC-A2(MV,V)20-2 Propeller Assembly.....	Figure 3-36..... 3-131
HC-A3(MV,V)20-2() Propeller Assembly.....	Figure 3-37..... 3-132
Spring Assembly-to-Cylinder Attachment Details	Figure 3-38..... 3-134
Rear Hub Mounting Parts.....	Figure 3-39..... 3-135
Guide Rod Attachment Details	Figure 3-40..... 3-138
HC-A2(MV,V)20-3L Propeller Assembly.....	Figure 3-41..... 3-141
HC-A3(MV,V)20-3L Propeller Assembly.....	Figure 3-42..... 3-142
Rear Hub Mounting Parts on HC-A(2,3)(MV,V)20-3L Propeller	Figure 3-43..... 3-145
Information Tag on Beta Return Spring	Figure 3-44..... 3-148
Spinner Bulkhead Removal.....	Figure 3-45..... 3-164
Checking Blade Track.....	Figure 5-1..... 5-14
Blade Play	Figure 5-2..... 5-14
Reciprocating Engine Overspeed Limits	Figure 5-3..... 5-18
Lubrication Fitting	Figure 6-1..... 6-4
Lubrication Label	Figure 6-2..... 6-6
Repair Limitations.....	Figure 6-3..... 6-12
Location of Balance Weights.....	Figure 6-4..... 6-24
Adjusting Low Pitch	Figure 6-5..... 6-28

LIST OF TABLES

Page

O-ring and Propeller Mounting Hardware
Identification Table 3-1 3-10

Torque Table Table 3-2 3-22

Approved Touch-up Paints Table 6-1 6-16

Maximum Number of Balance Weights For
Non-Standard Installations Table 6-2 6-21

CONTENTSPage

1. Purpose	1-3
2. Airworthiness Limits.....	1-3
3. Airframe or Engine Modifications.....	1-3
4. Restrictions and Placards.....	1-4
5. General.....	1-4
A. Personnel Requirements	1-4
B. Maintenance Practices.....	1-5
C. Continued Airworthiness	1-7
D. Propeller Critical Parts	1-7
6. Reference Publications.....	1-7
7. Definitions.....	1-9
8. Abbreviations.....	1-13
9. Hartzell Propeller Inc. Product Support.....	1-14
10. Warranty Service	1-14
11. Hartzell Propeller Inc. Recommended Facilities.....	1-15

(This page is intentionally blank.)

1. Purpose

- A. This manual has been reviewed and accepted by the FAA. Additionally, the Airworthiness Limitations Section of this manual has been approved by the FAA.

CAUTION: KEEP THIS MANUAL WITH THE PROPELLER, OR WITH THE AIRCRAFT ON WHICH IT IS INSTALLED, AT ALL TIMES. THE LOG BOOK RECORD WITHIN THIS MANUAL MUST BE MAINTAINED, RETAINED CONCURRENTLY, AND BECOME A PART OF THE AIRCRAFT AND ENGINE SERVICE RECORDS.

- B. This manual supports the following two and three-bladed, "A" type steel hub reciprocating propellers: ground adjustable; constant speed, nonfeathering; constant speed, feathering; constant speed, reversing; and constant speed, feathering, and reversing.

- C. The purpose of this manual is to enable qualified personnel to install, operate, and maintain a Hartzell propeller. Separate manuals are available concerning overhaul procedures and specifications for the propeller.

- D. This manual covers different design types. Sample hub and blade model numbers within each design are covered in the Description and Operation chapter of this manual.

NOTE: All propeller models covered by this manual use aluminum propeller blades.

2. Airworthiness Limits

- A. Refer to the Inspection and Check chapter of this manual for Airworthiness Limits information.

3. Airframe or Engine Modifications

- A. Propellers are approved vibrationwise on airframe and engine combinations based on tests or analysis of similar installations. This data has demonstrated that propeller stress levels are affected by airframe configuration, airspeed, weight, power, engine configuration, and flight maneuvers. Aircraft modifications that can affect propeller stress include, but are not limited to: aerodynamic changes ahead of or behind the propeller, realignment of the thrust axis, increasing airspeed limits, decreasing stall speed, increasing or decreasing weight limits (less significant on piston engines), and the addition of approved flight maneuvers (utility and aerobatic).

- B. Engine modifications can also affect the propeller. The two primary categories of engine modifications are those that affect structure and those that affect power. An example of a structural engine modification is the alteration of the crankshaft or damper of a piston engine. Any change to the weight, stiffness or tuning of rotating components could result in a potentially dangerous resonant condition that is not detectable by the pilot. Most common engine modifications affect the power during some phase of operation. Some increase the maximum power output, while others improve the power available during hot and high operation (flat rating) or at off-peak conditions. Examples of such engine modifications include, but are not limited to: changes to the compressor, power turbine, or hot section of a turboprop engine; and on piston engines, the addition or alteration of a turbocharger or turbonormalizer, increased compression ratio, increased RPM, altered ignition timing, electronic ignition, full authority digital electronic controls (FADEC), or tuned induction or exhaust.
- C. All such modifications must be reviewed and approved by the propeller manufacturer before obtaining approval on the aircraft.

4. Restrictions and Placards

The propellers covered by this manual may have a restricted operating range that requires a cockpit placard. The restrictions, if present, will vary depending on the propeller, blade, engine, and/or aircraft model. Review the propeller and aircraft type certificate data sheet (TCDS), Pilot Operating Handbook (POH), and any applicable Airworthiness Directives for specific information.

5. General

A. Personnel Requirements

- (1) Personnel performing maintenance are expected to have sufficient training and certifications (when required by the applicable Aviation Authority) to accomplish the work required in a safe and airworthy manner.
- (2) Compliance to the applicable regulatory requirements established by the Federal Aviation Administration (FAA) or foreign equivalent is mandatory for anyone performing or accepting responsibility for any inspection and/or repair and/or overhaul of any Hartzell Propeller Inc. product.

B. Maintenance Practices

- (1) The propeller and its components are highly vulnerable to damage while they are removed from the engine. Properly protect all components until they are reinstalled on the engine.
- (2) Never attempt to move the aircraft by pulling on the propeller.
- (3) Avoid the use of blade paddles, if possible. Do not place the blade paddle in the area of the de-ice boot when applying torque to a blade assembly. Place the blade paddle in the thickest area of the blade, just outside of the de-ice boot. Use one blade paddle per blade.
- (4) Use only the approved consumables (e.g. cleaning agents, lubricants, etc.).
- (5) **Safe Handling of Paints and Chemicals**
 - (a) Always use caution when handling or being exposed to paints and/or chemicals during propeller overhaul and maintenance procedures.
 - (b) Before using paint or chemicals, always read the manufacturer's label on the container and follow specified instructions and procedures for storage, preparation, mixing, and application.
 - (c) Refer to the product's Material Safety Data Sheet (MSDS) for detailed information about physical properties, health, and physical hazards of any chemical.
- (6) Observe applicable torque values during maintenance.
- (7) Before installing the propeller on the engine, the propeller must be statically balanced. New propellers are statically balanced at Hartzell Propeller Inc.. Overhauled propellers must be statically balanced by a certified propeller repair station with the appropriate rating before return to service.

NOTE: Dynamic balance is recommended, but may be accomplished at the discretion of the operator, unless specifically required by the airframe or engine manufacturer. Dynamic balancing must be accomplished in accordance with the procedures and limitations in the Maintenance Practices chapter of this manual. Additional procedures can be found in the aircraft maintenance manual.

- (8) As necessary, use a soft, non-graphite pencil or crayon to make identifying marks on components.
- (9) As applicable, follow military standard NASM33540 for safety wire, safety cable, and cotter pin general practices. Use 0.032 inch (0.81 mm) diameter stainless steel safety wire unless otherwise indicated.
- (10) The airframe manufacturer's manuals should be used in addition to the information in this manual, due to possible special requirements for specific aircraft applications.
- (11) If the propeller is equipped with an anti-ice system, applicable instructions and technical information can be obtained by contacting Hartzell Propeller Inc. Product Support at (937) 778-4379 (business hours are 8:00 a.m. through 5:00 p.m., United States Eastern Time).
- (12) If the propeller is equipped with an ice protection system that uses components supplied by Hartzell Propeller Inc., applicable instructions and technical information for the components supplied by Hartzell Propeller Inc. can be found in the following publications, available on the Hartzell Propeller Inc. website at www.hartzellprop.com:
 - (a) Hartzell Propeller Inc. Manual No. 180 (30-61-80) - Propeller Ice Protection System Manual
 - (b) Hartzell Propeller Inc. Manual No. 181 (30-60-81) - Propeller Ice Protection System Component Maintenance Manual
 - (c) Hartzell Propeller Inc. Manual No. 182 (61-12-82) - Propeller Electrical De-ice Boot Removal and Installation Manual
 - (d) Hartzell Propeller Inc. Manual No. 183 (61-12-83) - Propeller Anti-icing Boot Removal and Installation Manual
- (13) Propeller ice protection system components not supplied by Hartzell Propeller Inc. are controlled by the applicable TC or STC holder's Instructions for Continued Airworthiness (ICA).

(14) Approved corrosion protection followed by approved paint must be applied to all aluminum blades. For information concerning the application of corrosion protection and paint, refer to the Maintenance Practices chapter of this manual. Operation of blades without the specified coatings and finishes, e.g., "polished blades" is not permitted.

C. Continued Airworthiness

Operators are urged to stay informed of airworthiness information via Hartzell Propeller Inc. Service Bulletins and Service Letters which are available from Hartzell Propeller Inc. distributors, or from the Hartzell Propeller Inc. factory by subscription. Selected information is also available on Hartzell Propeller's website at www.hartzellprop.com.

D. Propeller Critical Parts

(1) The following maintenance procedures may involve propeller critical parts. These procedures have been substantiated based on Engineering analysis that expects this product will be operated and maintained using the procedures and inspections provided in the Instructions for Continued Airworthiness (ICA) for this product. Refer to the Illustrated Parts List chapter of the applicable maintenance manual for the applicable propeller model for the identification of specific Propeller Critical Parts.

(2) Numerous propeller system parts can produce a propeller Major or Hazardous effect, even though those parts may not be considered as Propeller Critical Parts. The operating and maintenance procedures and inspections provided in the ICA for this product are, therefore, expected to be accomplished for all propeller system parts.

6. Reference Publications

The following publications contain information vital to the airworthiness of the propeller models covered in this manual:

Hartzell Propeller Inc. Manual No. 114C (61-10-14) - Steel Hub Propeller Maintenance Manual

Hartzell Propeller Inc. Manual No. 171 (61-10-71) - -1, -4, -6 Series Steel "A" Hub Propeller Maintenance Manual

Hartzell Propeller Inc. Manual No. 172 (61-10-72) - -2 Series Steel "A" Hub Propeller Maintenance Manual

Active Hartzell Propeller Inc. Service Bulletins, Letters, Instructions, and Advisories

Hartzell Propeller Inc. Manual No. 127 (61-16-27) - Spinner Assembly Maintenance

Hartzell Propeller Inc. Manual No. 130B (61-23-30) - Mechanically Actuated Governor Maintenance Manual

Hartzell Propeller Inc. Manual No. 133C (61-13-33) - Aluminum Propeller Blade Maintenance Manual

Hartzell Propeller Inc. Manual No. 159 (61-02-59) - Application Guide - Also available on the Hartzell Propeller Inc. website at www.hartzellprop.com

Hartzell Propeller Inc. Manual No. 165A (61-00-65) - Illustrated Tool and Equipment Manual.

Hartzell Propeller Inc. Manual No. 180 (30-61-80) - Propeller Ice Protection System Manual (Available on the Hartzell Propeller Inc. website at www.hartzellprop.com.)

Hartzell Propeller Inc. Manual No. 181 (30-60-81) - Propeller Ice Protection System Component Maintenance Manual (Available on the Hartzell Propeller Inc. website at www.hartzellprop.com.)

Hartzell Propeller Inc. Manual No. 182 (61-12-82) - Propeller Electrical De-ice Boot Removal and Installation Manual (Available on the Hartzell Propeller Inc. website at www.hartzellprop.com.)

Hartzell Propeller Inc. Manual No. 183 (61-12-83) - Propeller Anti-icing Boot Removal and Installation Manual (Available on the Hartzell Propeller Inc. website at www.hartzellprop.com.)

Hartzell Propeller Inc. Manual No. 202A (61-01-02) - Standard Practices Manual - Volumes 1 through 11

Hartzell Propeller Inc. Service Letter HC-SL-61-61Y - Overhaul Periods and Service Life Limits for Hartzell Propellers, Governors, and Propeller Damper Assemblies - Also available on the Hartzell Propeller Inc. website at www.hartzellprop.com

7. Definitions

A basic understanding of the following terms will assist in maintaining and operating Hartzell propeller systems.

<u>Term</u>	<u>Definition</u>
Annealed	Softening of material due to overexposure to heat
Blade Angle	Measurement of blade airfoil location described as the angle between the blade airfoil and the surface described by propeller rotation
Brinelling.....	A depression caused by failure of the material in compression
Chord.....	A straight line distance between the leading and trailing edges of an airfoil
Cold Rolling	Compressive rolling process that provides improved strength and resistance to fatigue
Constant Force	A force which is always present in some degree when the propeller is operating
Constant Speed.....	A propeller system which employs a governing device to maintain a selected engine RPM
Corrosion	Gradual material removal or deterioration due to chemical action
Crack	Irregularly shaped separation within a material, sometimes visible as a narrow opening at the surface
Depression	Surface area where the material has been compressed but not removed
Distortion	Alteration of the original shape or size of a component

<u>Term</u>	<u>Definition</u>
Erosion	Gradual wearing away or deterioration due to action of the elements.
Exposure	Leaving material open to action of the elements.
Feathering	A propeller with blades that may be rotated to a position parallel to the relative wind, thus reducing aerodynamic drag.
Gouge.....	Surface area where material has been removed
Hazardous Propeller	
Effect	The hazardous propeller effects are defined in Title 14 CFR section 35.15(g)(1).
Horizontal Balance	Balance between the blade tip and the center of the hub.
Impact Damage	Damage that occurs when the propeller blade or hub assembly strikes, or is struck by, an object while in flight or on the ground.
Major Propeller Effect ..	The major propeller effects are defined in Title 14 CFR section 35.15(g)(2).
Nick	Removal of paint and possibly a small amount of material.
Onspeed.....	Condition in which the RPM selected by the pilot through the propeller control lever and the actual engine (propeller) RPM are equal.
Overhaul.....	The periodic disassembly, inspection, repair, refinish, and reassembly of a propeller assembly to maintain airworthiness.

<u>Term</u>	<u>Definition</u>
Overspeed	Condition in which the RPM of the propeller or engine exceeds predetermined maximum limits; the condition in which the engine (propeller) RPM is higher than the RPM selected by the pilot through the propeller control lever
Overspeed Damage	Damage that occurs when the propeller hub assembly rotates at a speed greater than the maximum limit for which it is designed.
Pitch.....	Same as "Blade Angle"
Pitting.....	Formation of a number of small, irregularly shaped cavities in surface material caused by corrosion or wear.
Propeller Critical Part . .	A part on the propeller whose primary failure can result in a hazardous propeller effect, as determined by the safety analysis required by Title 14 CFR section 35.15
Scratch	Same as "Nick"
Single Acting.....	Hydraulically actuated propeller which utilizes a single oil supply for pitch control
Synchronizing	Adjusting the RPM of all the propellers of a multi-engine aircraft to the same RPM
Synchrophasing.....	A form of propeller synchronization in which not only the RPM of the engines (propellers) are held constant, but also the position of the propellers in relation to each other

<u>Term</u>	<u>Definition</u>
Track.....	In an assembled propeller, a measurement of the location of the blade tip with respect to the plane of rotation, used to verify face alignment and to compare blade tip location with respect to the locations of the other blades in the assembly.
Underspeed	The condition in which the actual engine (propeller) RPM is lower than the RPM selected by the pilot through the propeller control lever.
Vertical Balance.....	Balance between the leading and trailing edges of a two-blade propeller, with the blades positioned vertically.
Variable Force	A force which may be applied or removed during propeller operation.
Windmilling	The rotation of an aircraft propeller caused by air flowing through it while the engine is not producing power.

8. Abbreviations

<u>Abbreviation</u>	<u>Term</u>
AMM	Aircraft Maintenance Manual
AN.....	Air Force-Navy (or Army-Navy)
AOG.....	Aircraft on Ground
FAA.....	Federal Aviation Administration
Ft-Lb	Foot-Pound
ICA.....	Instructions for Continued Airworthiness
ID	Inside Diameter
In-Lb	Inch-Pound
IPS.....	Inches Per Second
kPa	Kilopascals
Lbs.....	Pounds
MIL-X-XXX.....	Military Specification
MPI	Major Periodic Inspection
MS	Military Standard
MSDS	Material Safety Data Sheet
NAS	National Aerospace Standards
NIST	National Institute of Standards and Technology
N•m.....	Newton-Meters
OD	Outside Diameter
POH.....	Pilot Operating Handbook
PSI.....	Pounds per Square Inch
RPM.....	Revolutions per Minute
TBO	Time Between Overhaul
TC.....	Type Certificate
TSN	Time Since New
TSO	Time Since Overhaul

NOTE: TSN/TSO is considered as the time accumulated between rotation and landing (i.e. flight time).

9. Hartzell Propeller Inc. Product Support

Hartzell Propeller Inc. is ready to assist you with questions concerning your propeller system. Hartzell Propeller Inc. Product Support may be reached during business hours (8:00 a.m. through 5:00 p.m., United States Eastern Time) at (937) 778-4379 or at (800) 942-7767, toll free from the United States and Canada. Hartzell Propeller Inc. Product Support can also be reached by fax at (937) 778-4391, and by e-mail at techsupport@hartzellprop.com.

After business hours, you may leave a message on our 24 hour product support line at (937) 778-4376 or at (800) 942-7767, toll free from the United States and Canada. A technical representative will contact you during normal business hours. Urgent AOG support is also available 24 hours per day, seven days per week via this message service.

Additional information is available on our website at www.hartzellprop.com.

NOTE: When calling from outside the United States, dial (001) before dialing the above telephone numbers.

10. Warranty Service

If you believe you have a warranty claim, it is necessary to contact Hartzell's Warranty Administrator. Hartzell's Warranty Administrator will provide you with a *Warranty Application* form. It is necessary to complete this form and return it to the Warranty Administrator for evaluation **before proceeding with repair or inspection work**. Upon receipt of this form, the Warranty Administrator will provide instructions on how to proceed. Hartzell Propeller Inc. Warranty may be reached during business hours (8:00 a.m. through 5:00 p.m., United States Eastern Time) at (937)-778-4379 or toll free from the United States and Canada at (800) 942-7767. Hartzell Propeller Inc. Warranty Administration can also be reached by fax at (937) 778-4391, or by e-mail at warranty@hartzellprop.com.

NOTE: When calling from outside the United States, dial (001) before dialing the above telephone numbers.

11. Hartzell Propeller Inc. Recommended Facilities

- A. Hartzell Propeller Inc. recommends using Hartzell approved distributors and repair facilities for the purchase, repair and overhaul of Hartzell Propeller Inc. propeller assemblies or components.
- B. Information about the Hartzell Propeller Inc. worldwide network of aftermarket distributors and approved repair facilities is available on the Hartzell Propeller Inc. website at www.hartzellprop.com.

(This page is intentionally blank.)

CONTENTS **Page**

1. Description of Propeller and Systems	2-3
A. Ground Adjustable Pitch Propeller	2-7
B. Constant Speed, Non-counterweighted, Nonfeathering Propellers	2-9
C. Constant Speed, Counterweighted, Nonfeathering Propellers	2-13
D. Constant Speed and Feathering Propellers	2-17
E. Constant Speed, Feathering and Reversing Propellers (External Beta System)	2-21
F. Constant Speed and Reversing Propellers (External Beta System)	2-27
G. Constant Speed, Feathering and Reversing Propellers...	2-31
2. Model Designation	2-34
A. Steel Hub Propeller Model Identification	2-34
B. Aluminum Blade Model Identification	2-37
C. Conversion From V Shank to MV Shank	2-38
3. Governors	2-41
A. Theory of Operation	2-41
B. Governor Types	2-44
C. Identification of Hartzell Governors	2-44
4. Propeller Ice Protection Systems	2-45
A. Propeller Anti-Ice System	2-45
B. Propeller De-Ice System	2-46

	<u>FIGURES</u>	<u>Page</u>
Steel Hub Unit (For Splined Shaft Mounting).....	Figure 2-1	2-3
Spline Shaft Attachment.....	Figure 2-2	2-4
Flanged Attachment.....	Figure 2-3	2-5
Ground Adjustable Propeller Assembly ..	Figure 2-4	2-6
Constant Speed, Non-counterweighted, Nonfeathering Propeller Assembly.....	Figure 2-5	2-8
Constant Speed, Counterweighted, Nonfeathering Propeller Assembly.....	Figure 2-6	2-11
Constant Speed, Counterweighted, Nonfeathering Propeller Assembly.....	Figure 2-7	2-12
Constant Speed, Feathering Propeller Assembly.....	Figure 2-8	2-15
Constant Speed, Feathering Propeller Assembly.....	Figure 2-9	2-16
Constant Speed, Feathering and Reversing Propeller Assembly (External Beta System)	Figure 2-10	2-20
Fundamental Elements of a Reversing System.....	Figure 2-11	2-22
Constant Speed, and Reversing Propeller Assembly (External Beta System)	Figure 2-12	2-26
Constant Speed, Feathering and Reversing Propeller Assembly (Internal Beta System).....	Figure 2-13	2-30
Governor in Onspeed Condition.....	Figure 2-14	2-40
Governor in Underspeed Condition.....	Figure 2-15	2-40
Governor in Overspeed Condition.....	Figure 2-16	2-40
Feathering Governor	Figure 2-17	2-42
Synchronizer/Synchrophaser Governor....	Figure 2-18	2-42

1. Description of Propeller and Systems

Hartzell steel hub propellers are either ground adjustable or constant speed assemblies that use a steel hub as a central component (Figure 2-1).

The propeller attaches to the engine through either a splined shaft or one of several flanged designs. A spline shaft attachment uses either a Society of Automotive Engineers (SAE) Number 20 or Number 30 spline (Figure 2-2).

NOTE: SAE Number 20 and SAE Number 30 spline shaft propellers are identified simply as "20 spline shaft" and "30 spline shaft" propellers throughout the text of this manual.

A flanged shaft attachment uses a six-bolt and two dowel pin interface or a six bolt and four bushing interface between the engine and the propeller flange (Figure 2-3).

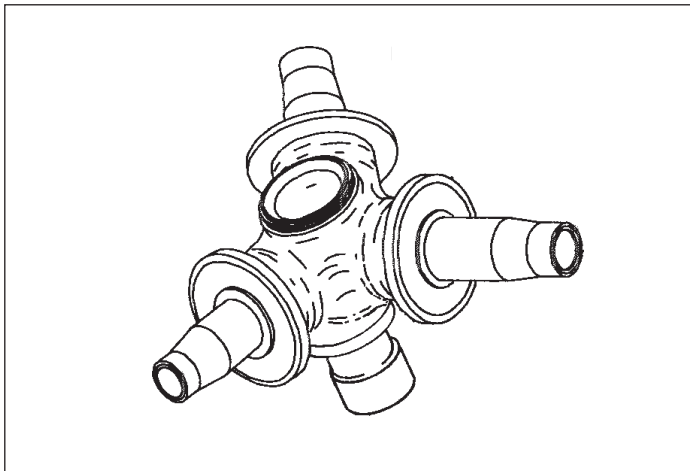

**Steel Hub Unit (For Splined Shaft Mounting)
Figure 2-1**

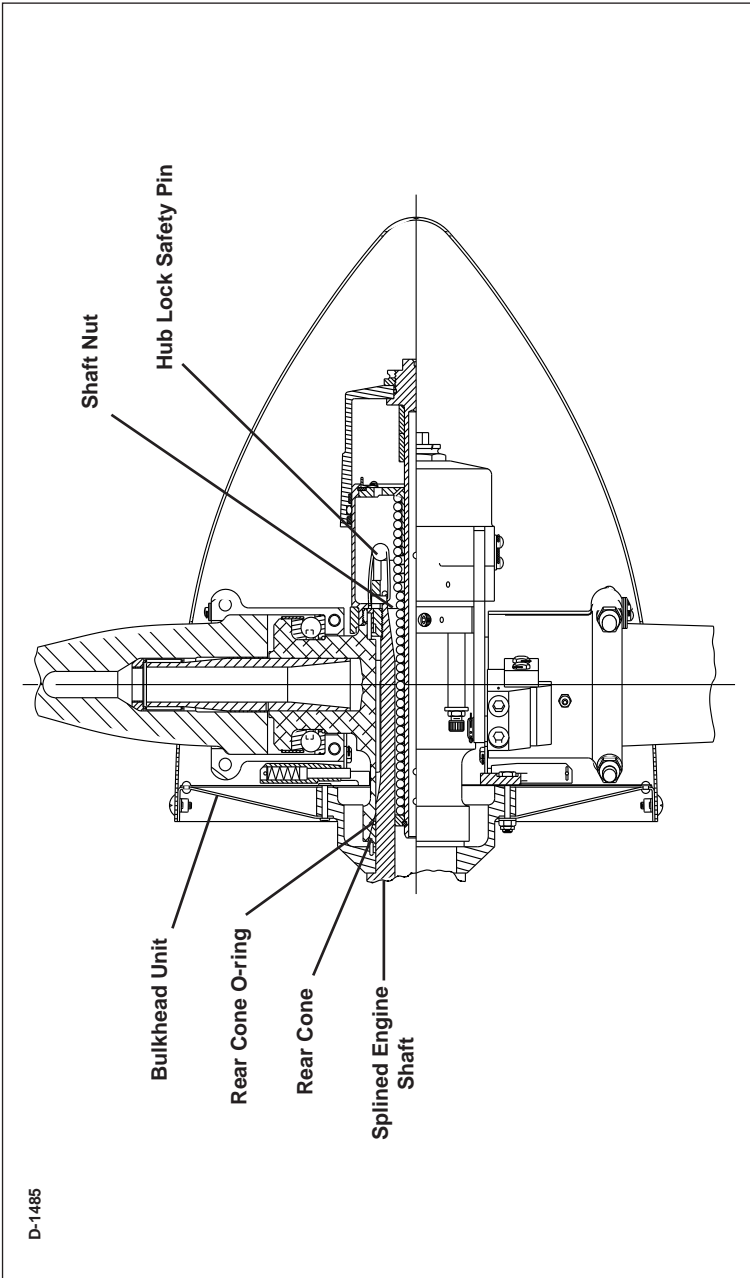

D-1485

Spline Shaft Attachment
Figure 2-2

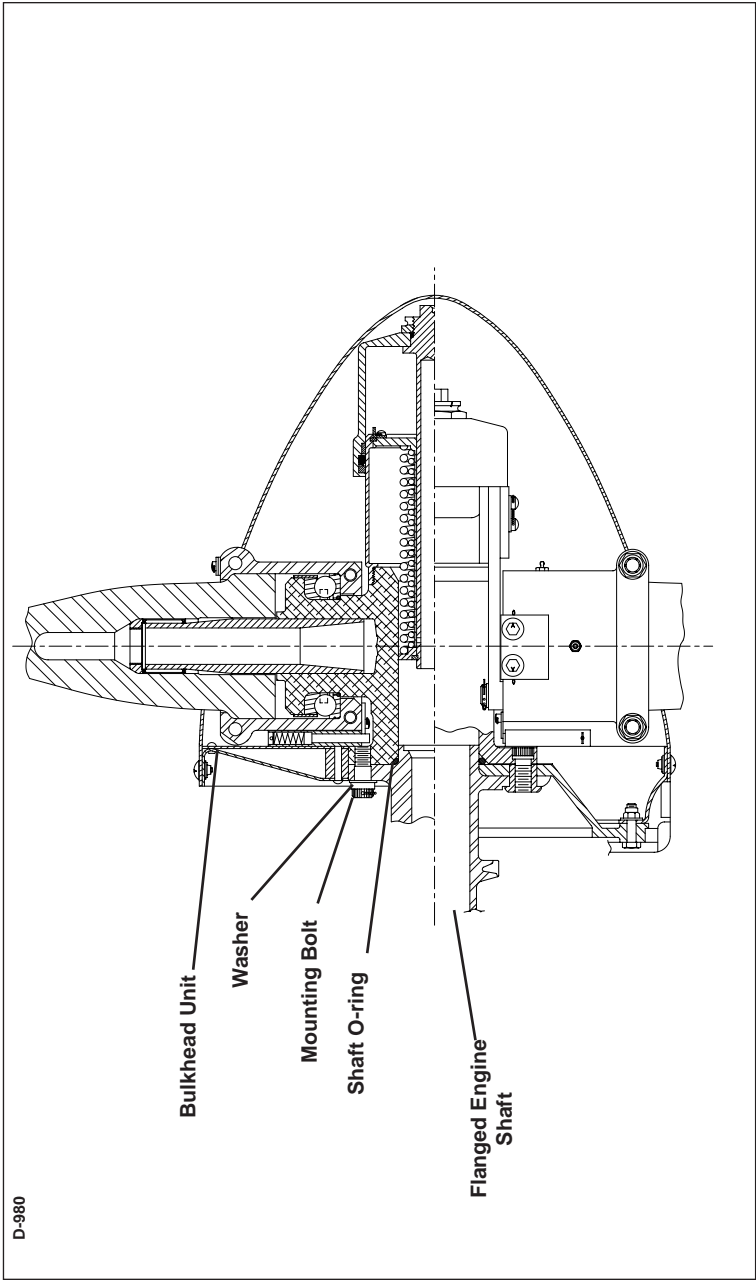

D-980

Flanged Attachment
Figure 2-3

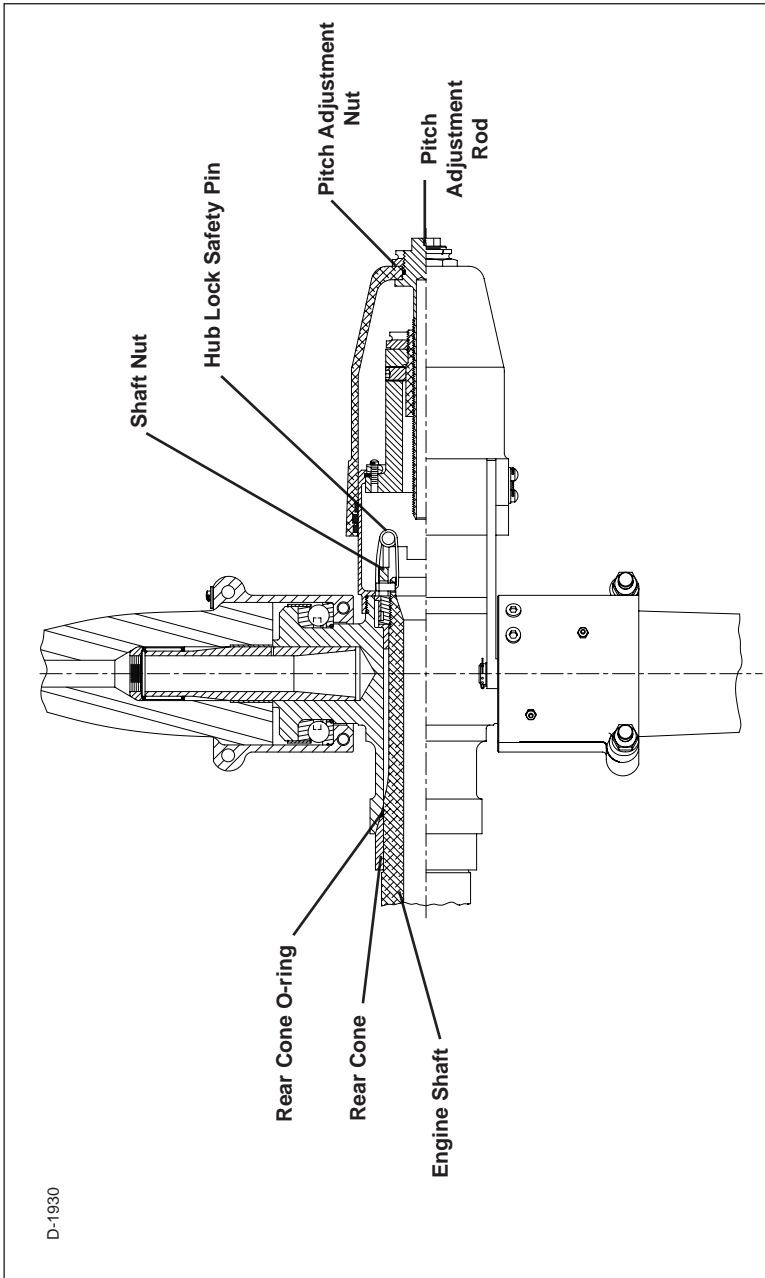

D-1930

Ground Adjustable Propeller Assembly
Figure 2-4

A. Ground Adjustable Pitch Propellers

Propeller models HA-A2(MV,V)20-1B

Refer to Figure 2-4.

Ground adjustable pitch propellers are typically used on single engine aircraft equipped with an engine that does not support governing capability nor is able to supply oil through a hollow shaft to the propeller.

Ground adjustable pitch propellers may be set to a desired blade pitch by manually adjusting the propeller when the aircraft is static on the ground. This allows an optimal blade pitch to be selected for different flight conditions, such as climb or cruise. A propeller adjusted for climb will not fly very fast (unless engine RPM's are excessively high). A propeller adjusted for cruise will need more runway for takeoff and will climb more slowly (engine RPM will be less than optimum).

Ground adjustable propellers do not require a governor or any oil supply, as they do not change blade pitch in flight.

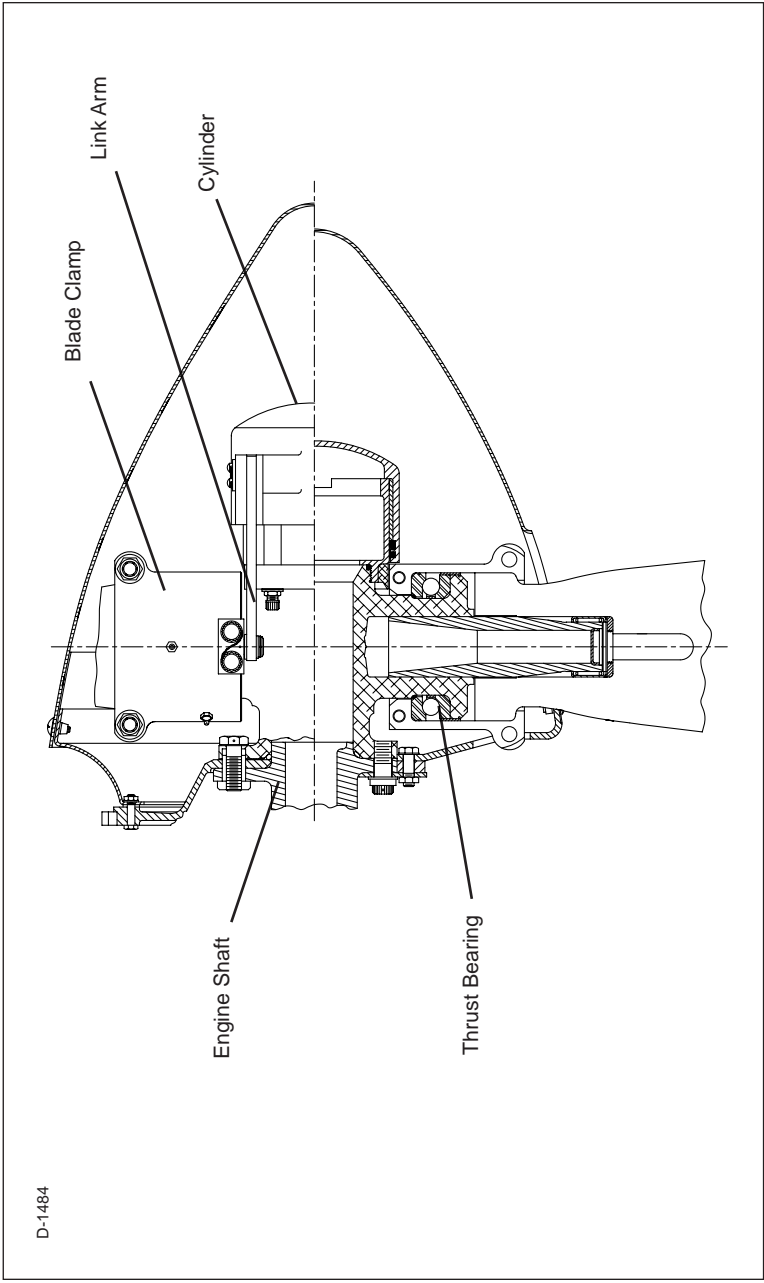

D-1484

Constant Speed, Non-counterweighted, Nonfeathering Propeller Assembly
Figure 2-5

B. Constant Speed, Non-counterweighted, Nonfeathering Propellers

Propeller models (P)HC-A3(MV,V)(F,K)-4()
Refer to Figure 2-5.

Constant speed, non-counterweighted, nonfeathering propellers are typically used on single engine aircraft.

Propeller blade angle change is actuated by a hydraulic piston/cylinder combination mounted on the forward end of the propeller hub. The linear motion of the hydraulic piston is transmitted to each blade through a link arm system, connected to a blade clamp that rotates with the blade. Each blade is retained on the propeller hub by a blade clamp and thrust bearing. The thrust bearing allows the blade to change angle with the blade under centrifugal load.

Propeller forces consisting of centrifugal and aerodynamic twisting moment of the blades in various combinations are constantly present while the propeller is operating. The summation of these forces causes the propeller to rotate to a lower blade angle. A variable hydraulic force (oil under pressure from the engine driven governor) toward a higher blade angle opposes the summation of these forces. Oil is metered by the governor to oppose these constant forces and maintain a constant engine RPM.

A non-counterweighted propeller requires governor supplied oil to increase blade angle. If the oil supply is lost, the non-counterweighted propeller will go to low pitch, or high RPM.

The weight of each propeller blade when spinning, generates centrifugal force and a twisting force that attempts to rotate each blade to a lower blade angle.

Air flow around the blade generates lift and an aerodynamic twisting moment that will attempt to increase or decrease blade angle, depending on flight conditions and blade design. This force is generally very small in relation to the other forces.

A governor is an engine speed-sensing device that maintains a constant engine/propeller RPM by changing blade angle and varying load on the engine.

The governor uses an internal pump that is driven by an accessory drive from the engine. This pump uses an engine oil supply and increases the engine oil pressure for supply to the propeller. Engine speed sensing hardware within the governor controls the supply of oil to, or drain of oil from the propeller, resulting in a change of blade pitch to maintain constant engine speed.

Oil pressure from the engine-driven governor is supplied to the propeller mounted hydraulic cylinder through the engine shaft and propeller hub. Increasing the oil volume within the hydraulic cylinder increases blade angle to decrease engine RPM. Decreasing the oil volume will decrease blade angle to increase engine RPM. By changing the blade angle, the governor maintains constant engine RPM (within limits), independent of the throttle setting.

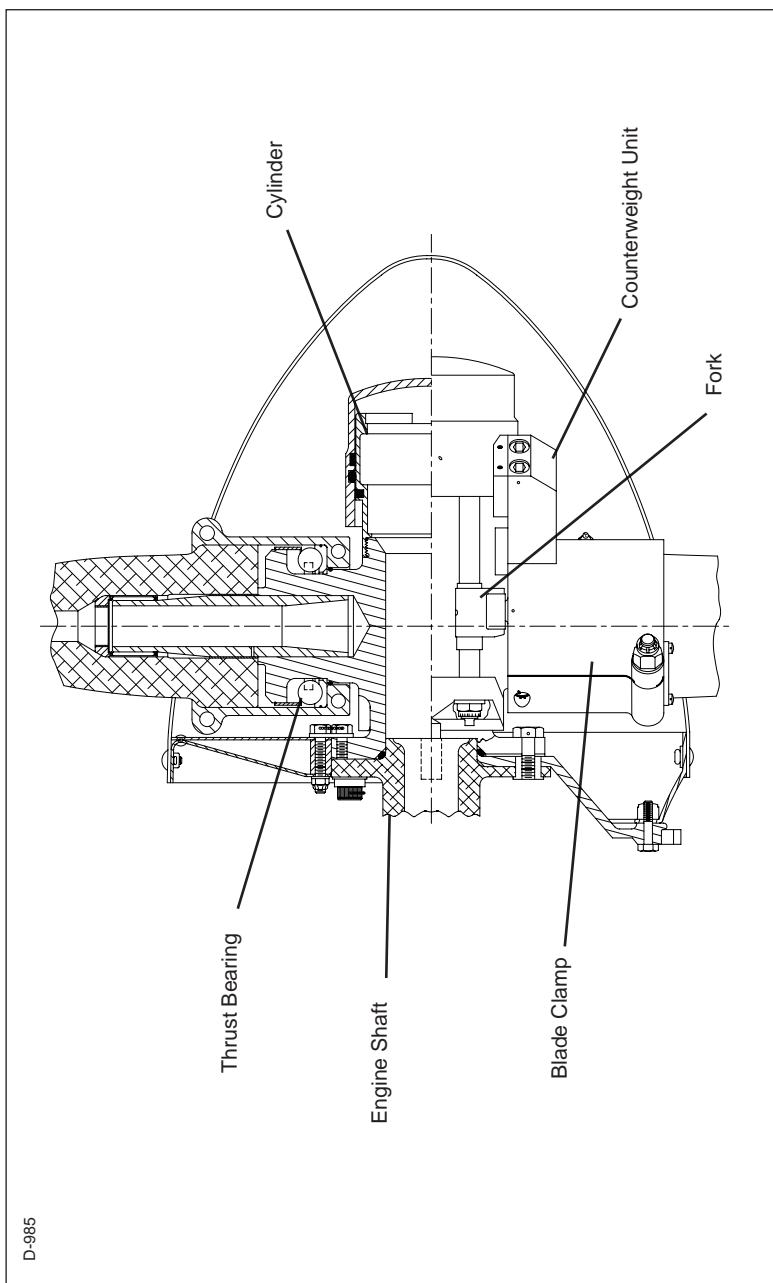

Constant Speed, Counterweighted, Nonfeathering Propeller Assembly
Figure 2-6

D-985

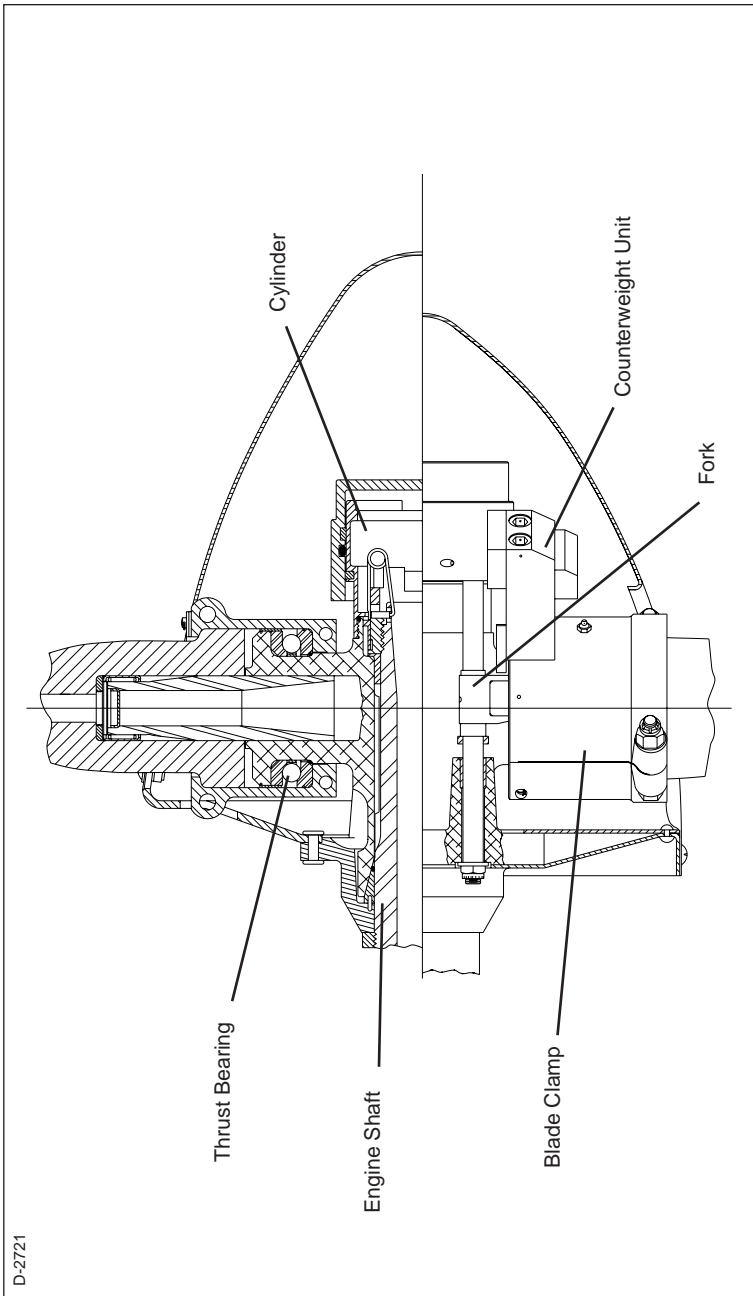

Constant Speed, Counterweighted, Nonfeathering Propeller Assembly
Figure 2-7

D-2721

C. Constant Speed, Counterweighted, Nonfeathering Propellers

Propeller models (B)HC-A2(MV,V)(F,K,L)-1(), HC-A2(MV,V)20-1A, HC-A3(MV,V)20-1(), and HC-A2(MV,V)L-6F.

Refer to Figures 2-6 and 2-7.

Constant speed counterweighted, nonfeathering propellers are typically used on single engine aircraft.

Propeller blade angle change is actuated by a hydraulic piston/cylinder combination mounted on the forward end of the propeller hub. The linear motion of the hydraulic piston is transmitted to each blade through a sliding rod and fork system, connected to a blade clamp that rotates with the blade. Each blade is retained on the propeller hub by a blade clamp and thrust bearing. The thrust bearing allows the blade to change angle with the blade under centrifugal load.

Propeller forces consisting of blade counterweight centrifugal twisting moment and aerodynamic twisting moment of the blades in various combinations are constantly present while the propeller is operating. The summation of these forces causes the propeller to rotate to a higher blade angle. A variable hydraulic force (oil under pressure from the engine driven governor) toward a lower blade angle opposes the summation of these forces. Oil is metered by the governor to oppose these constant forces and maintain a constant engine RPM.

A counterweight is a weight that is attached to each blade clamp to cause the blade to rotate to a higher blade pitch. Counterweighted propellers require governor supplied oil to decrease blade pitch. If the oil supply is lost, the counterweighted propeller will go to high pitch, or low RPM.

The weight of each propeller blade when spinning, generates centrifugal force and a twisting force that attempts to rotate each blade to a lower blade angle.

Air flow around the blade generates lift and an aerodynamic twisting moment that will attempt to increase or decrease blade angle, depending on flight condition and blade design. This force is generally very small in relation to the other forces.

A governor is an engine speed-sensing device that maintains a constant engine/propeller RPM by changing blade angle and varying load on the engine.

The governor uses an internal pump that is driven by an accessory drive from the engine. This pump uses an engine oil supply and increases the engine oil pressure for supply to the propeller. Engine speed sensing hardware within the governor controls the supply of oil to, or drain of oil from the propeller, resulting in a change of blade pitch to maintain constant engine speed.

Oil pressure from the engine-driven governor is supplied to the propeller mounted hydraulic cylinder through the engine shaft and propeller hub. Increasing the oil volume within the hydraulic cylinder decreases blade angle to increase engine RPM. Decreasing the oil volume increases blade angle to decrease engine RPM. By changing the blade angle, the governor maintains constant engine RPM (within limits), independent of the throttle setting.

If oil pressure is lost at any time, the summation of propeller forces that is in direct opposition to the lost variable hydraulic force will increase blade angle.

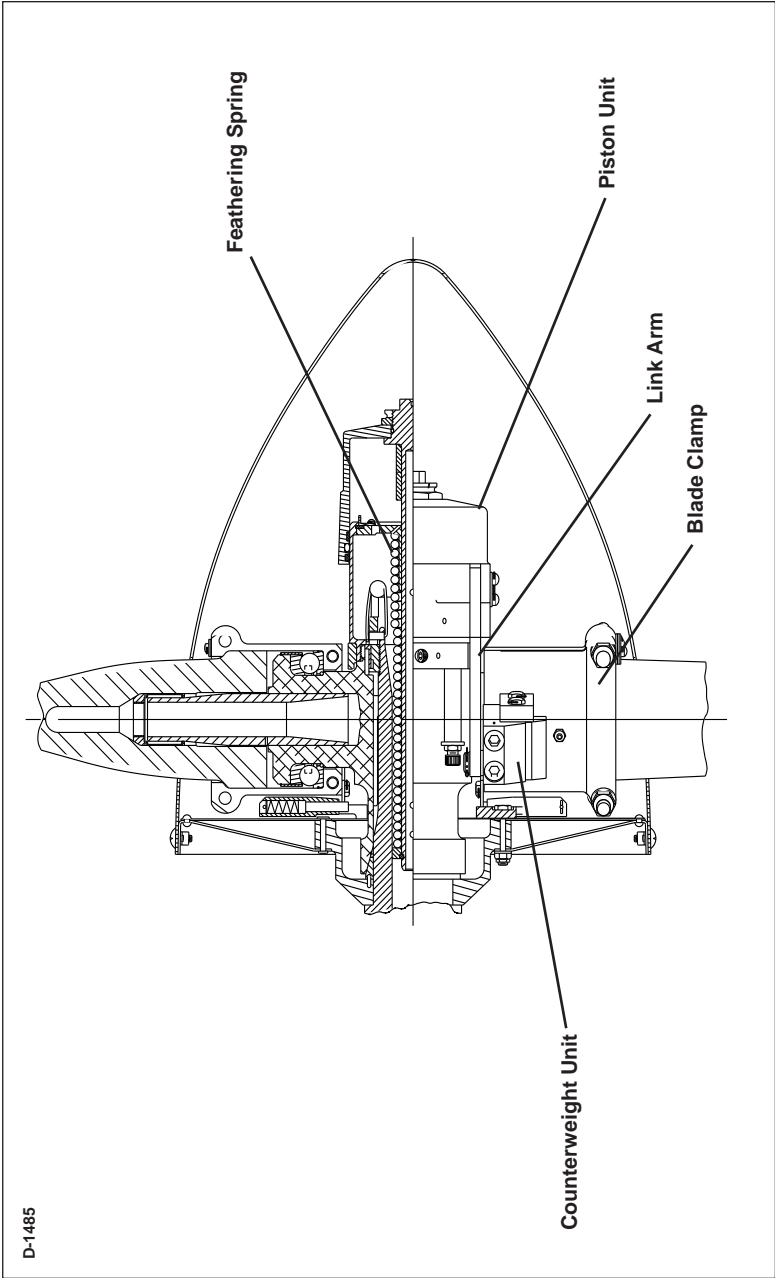

Constant Speed, Feathering Propeller Assembly
Figure 2-8

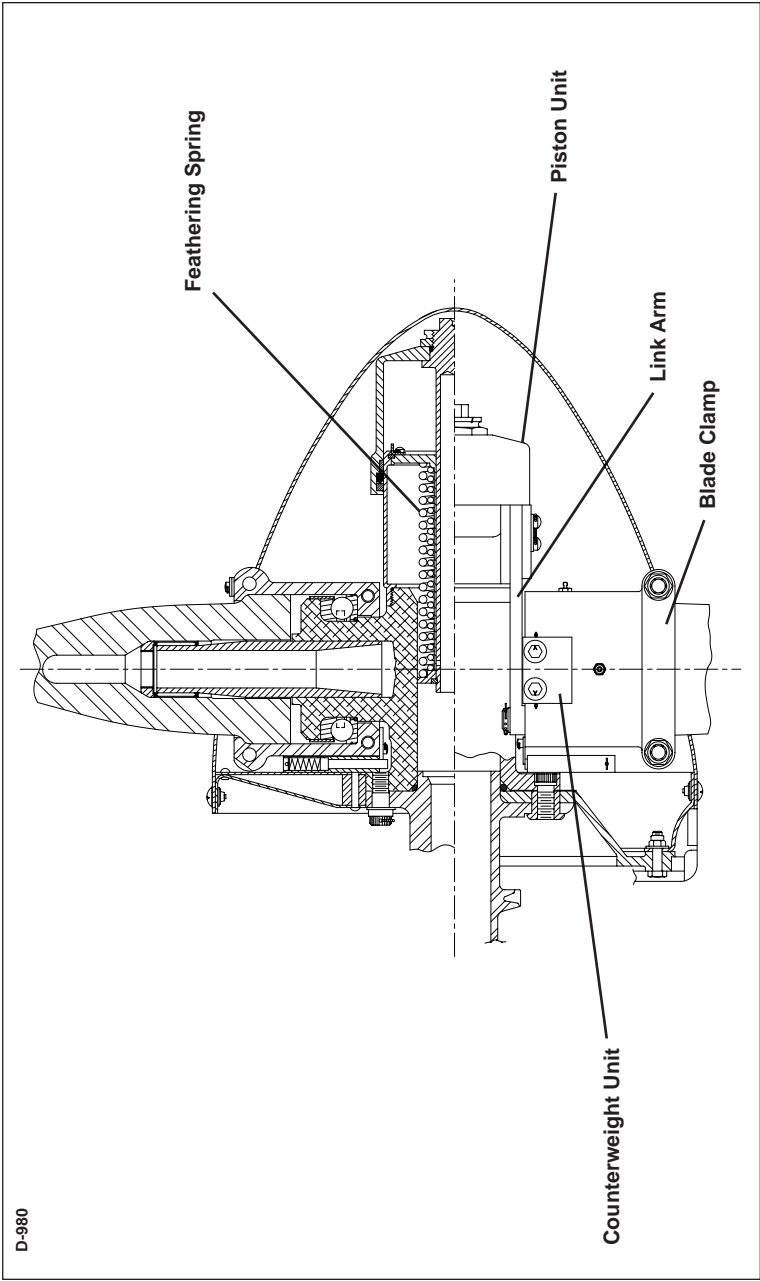

D-980

Constant Speed, Feathering Propeller Assembly
Figure 2-9

D. Constant Speed and Feathering Propellers

Propeller models HC-A2(MV,V)(F,K,L)-2(), HC-A2(MV,V)20-2, (E,P)HC-A3(MV,V)F-2(), HC-A3(MV,V)K-2()() and HC-A3(MV,V)20-2(). Refer to Figures 2-8 and 2-9.

A constant speed and feathering propeller is typically used on a twin engine aircraft. It is counterweighted, and is controlled by an engine speed-sensing device (governor) to maintain a constant engine/propeller RPM by changing blade angle and varying load on the engine.

Propeller blade angle change is actuated by a hydraulic piston/cylinder combination mounted on the forward end of the propeller hub. The linear motion of the hydraulic piston is transmitted to each blade through either a link arm system, or through a sliding rod and fork system, connected to a blade clamp that rotates with the blade. Each blade is retained on the propeller hub by a blade clamp and thrust bearing. The thrust bearing allows the blade to change angle.

Propeller forces consisting of mechanical spring action, counterweight twisting moment, and centrifugal and aerodynamic twisting moment of the blades in various combinations are constantly present while the propeller is operating. The summation of these forces causes the propeller to rotate to a higher pitch. A variable hydraulic force (oil under pressure from the engine driven governor) toward a lower blade pitch opposes the summation of these forces. Oil is metered by the governor to oppose these constant forces and maintain a constant engine RPM.

The forces of the installed spring and counterweight attempt to rotate the blades to a higher blade angle.

The counterweight is a weight that is attached to each blade clamp to cause the blade to rotate to a higher blade pitch. Counterweighted propellers require governor supplied oil to decrease blade pitch. If the oil supply is lost, the counterweighted propeller will go to feather.

The weight of each propeller blade when spinning, generates centrifugal force and a twisting force that attempts to rotate each blade to a lower blade angle.

Air flow around the blade generates lift and an aerodynamic twisting moment that attempts to increase or decrease blade angle, depending on flight condition and blade design. This force is generally very small in relation to the other forces.

A governor is an engine speed-sensing device that maintains a constant engine/propeller RPM by changing blade angle and varying load on the engine.

The governor uses an internal pump that is driven by an accessory drive from the engine. This pump uses an engine oil supply and increases the engine oil pressure for supply to the propeller. Engine speed sensing hardware within the governor controls the supply of oil to, or drain of oil from the propeller, resulting in a change of blade pitch to maintain constant engine speed.

Oil pressure from the engine-driven governor is supplied to the propeller mounted hydraulic cylinder through the engine shaft and propeller hub. Increasing the oil volume within the hydraulic cylinder decreases blade angle to increase engine RPM. Decreasing the oil volume will increase the blade angle to decrease engine RPM. By changing the blade angle, the governor maintains constant engine RPM (within limits), independent of the throttle setting.

If the oil supply is lost during flight, the propeller will feather. Feathering occurs because the spring and blade clamp mounted counterweight forces are no longer opposed by hydraulic oil pressure and are free to increase blade pitch to the feathering (high pitch) stop.

Normal in-flight feathering of these propellers is accomplished when the pilot retards the propeller pitch control past the feather detent. This allows oil to drain from the propeller and return to the engine sump. Engine shutdown is normally accomplished during the feathering process.

Normal in-flight unfeathering is accomplished when the pilot positions the propeller pitch control into normal flight (governing) range and restarts the engine. As engine speed increases, oil is supplied by the governor to the propeller, and the blade angle decreases.

It is undesirable to feather the propeller when the engine is stopped after landing. To prevent feathering during normal engine shut down, the propeller incorporates spring energized latches (start locks). If the propeller rotation is approximately 800 RPM or above, the latches are disengaged by centrifugal force acting on the latch weights to compress the springs. When the propeller drops below 800 RPM, the springs overcome the centrifugal force acting on the latch weights and move the latches to engage the start locks, preventing blade angle movement to feather.

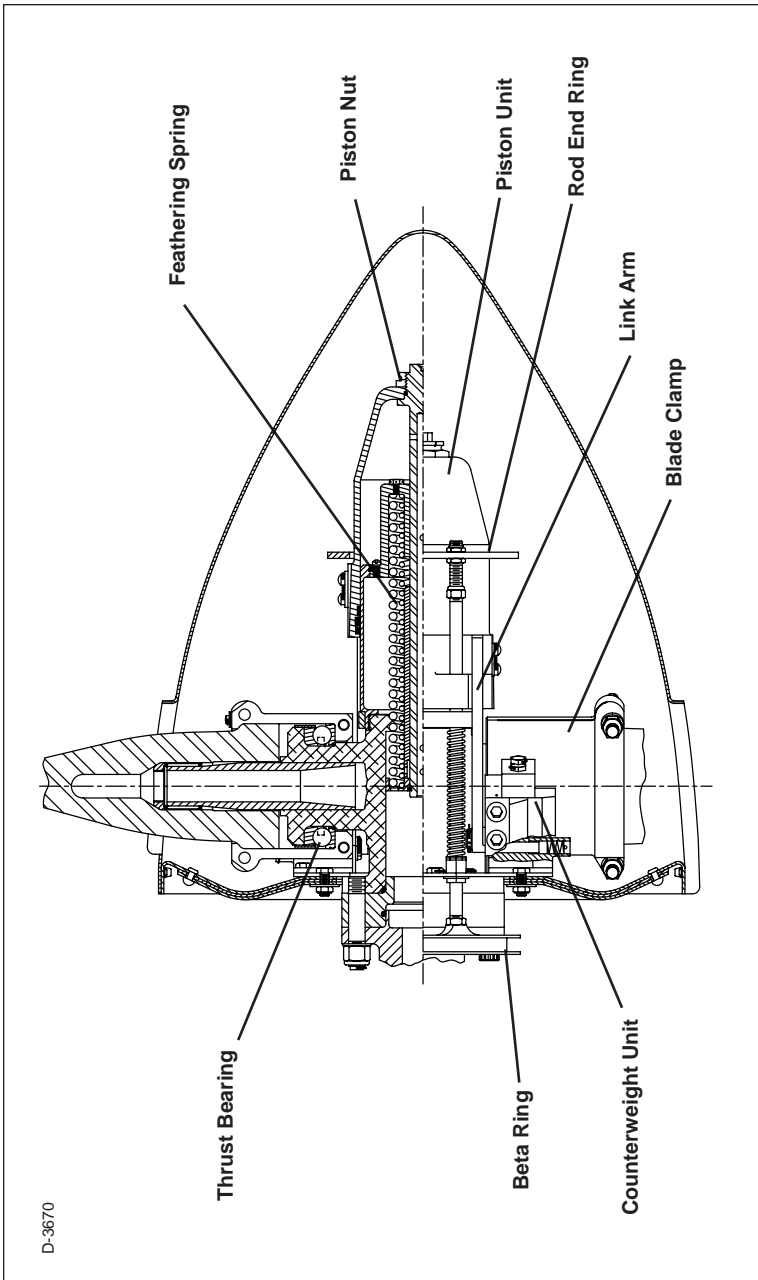

D-3670

**Constant Speed, Feathering and Reversing Propeller Assembly (External Beta System)
Figure 2-10**

E. Constant Speed, Feathering and Reversing Propellers
(External Beta System)

Propeller models (P)HC-A3(MV,V)F-5R.
Refer to Figure 2-10.

A constant speed, feathering and reversing propeller is typically used on a twin engine aircraft. It is counterweighted and has an external beta feedback system.

Propeller blade angle change is actuated by a hydraulic piston/cylinder combination mounted on the forward end of the propeller hub. The linear motion of the hydraulic piston is transmitted to each blade through a link arm system connected to a blade clamp that rotates with the blade. Each blade is retained on the propeller hub by a blade clamp and thrust bearing. The thrust bearing allows the blade to change angle.

Propeller forces consisting of mechanical spring action, counterweight twisting moment, and centrifugal and aerodynamic twisting moment of the blades in various combinations are constantly present while the propeller is operating. The summation of these forces causes the propeller to rotate to a higher pitch. A variable hydraulic force (oil under pressure from the engine driven governor) toward a lower blade pitch opposes the summation of these forces. Oil is metered by the governor to oppose these constant forces and maintain a constant engine RPM.

The forces of the installed spring and counterweight attempt to rotate the blades to a higher blade angle.

The counterweight is a weight that is attached to each blade clamp to cause the blade to rotate to a higher blade angle.

The weight of each propeller blade when spinning, generates centrifugal force and a twisting force that attempts to rotate each blade to a lower blade angle.

Air flow around the blade generates lift and an aerodynamic twisting moment that attempts to increase or decrease blade angle, depending on flight condition and blade design. This force is generally very small in relation to the other forces.

The governor uses an internal pump that is driven by an accessory drive from the engine. This pump uses an engine oil supply and increases the engine oil pressure for supply to the propeller. Engine speed sensing hardware within the governor controls the supply of oil to, or drain of oil from the propeller, resulting in a change of blade pitch to maintain constant engine speed.

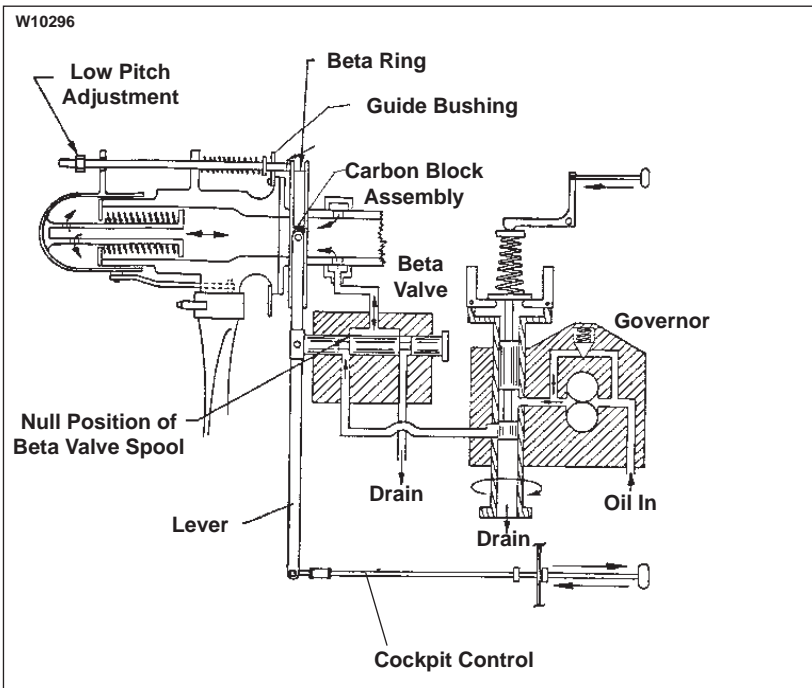

**Fundamental Elements of a Reversing System
Figure 2-11**

Oil pressure from the engine-driven governor is supplied to the propeller mounted hydraulic cylinder through the engine shaft and propeller hub. Increasing the oil volume within the hydraulic cylinder decreases blade angle to increase engine RPM. Decreasing the oil volume will increase blade angle to decrease engine RPM. By changing the blade angle, the governor maintains constant engine RPM (within limits), independent of the throttle setting.

The lowest blade angle attainable by the governor is low pitch. A beta valve hydraulically controls the low pitch stop and the blade angles between low pitch and reverse. Beta refers to the blade angle range between low pitch and full reverse blade angles.

NOTE: The beta valve is normally installed between the base of the governor and the engine.

In reverse mode of operation, the governor operates in an underspeed condition to act strictly as a source of pressurized oil, without attempting to control RPM. In this mode, the pilot input to the propeller (through cockpit controls) controls the blade angle, rather than RPM.

Fundamental elements of a reversing system include a beta valve, cockpit control cable, propeller mounted blade angle feedback mechanism (beta ring), carbon block, and a lever that interfaces between those four elements and the governor operating in underspeed (as an oil pressure source). Refer to Figure 2-11.

Propeller blade angle is moved into the beta range by manually repositioning the cockpit control to move the lever and move the beta valve spool to supply oil from the governor pump to the propeller. Propeller blade angle change or piston movement is communicated back to the beta valve through the propeller mounted beta ring, carbon block assembly, and lever. The repositioned beta valve spool will prevent oil from reaching the propeller when the desired blade angle is obtained in the beta range. Any additional unwanted movement of the propeller toward reverse will cause the beta valve to drain oil from the propeller to slightly increase pitch. Any unwanted movement toward higher pitch will cause the beta valve to pump oil to the propeller to slightly decrease pitch. Thus, movement of the cockpit control in one direction will move blade angles below low pitch and toward reverse pitch, and movement in the opposite direction will move blade angles back toward low pitch blade angle.

NOTE: Blade angle may be moved into beta only when the governor is in an underspeed condition, supplying oil to the propeller.

The blade angle selection by the cockpit control must be moved to the low pitch position before the engine is shut down. Otherwise, the reversing mechanism as shown in Figure 2-11 may be damaged when the internal propeller forces move the blades to a high blade angle above low pitch, even though the reversing linkage is still set for operation in the beta blade angle range.

If oil supply is lost during flight, the propeller will feather. Feathering occurs because the spring and blade clamp mounted counterweight forces are no longer opposed by hydraulic oil pressure and are free to increase blade pitch to the feathering (high pitch) stop.

Normal in-flight feathering of these propellers is accomplished when the pilot retards the propeller pitch control past the feather detent. This allows oil to drain from the propeller and return to the engine sump. Engine shutdown is normally accomplished during the feathering process.

Normal in-flight unfeathering is accomplished when the pilot positions the propeller pitch control into normal flight (governing) range and restarts the engine. As engine speed increases, oil is supplied by the governor to the propeller, and blade angle decreases.

It is undesirable to feather the propeller when the engine is stopped after landing. To prevent feathering during normal engine shut down, the propeller incorporates spring energized pins (start locks). If the propeller rotation is approximately 800 RPM or above, the pins are disengaged by centrifugal force acting on the them to compress the springs. When the propeller drops below 800 RPM, the springs overcome the centrifugal force acting on the latch weights and move the latches to engage the start locks, preventing blade angle movement to feather.

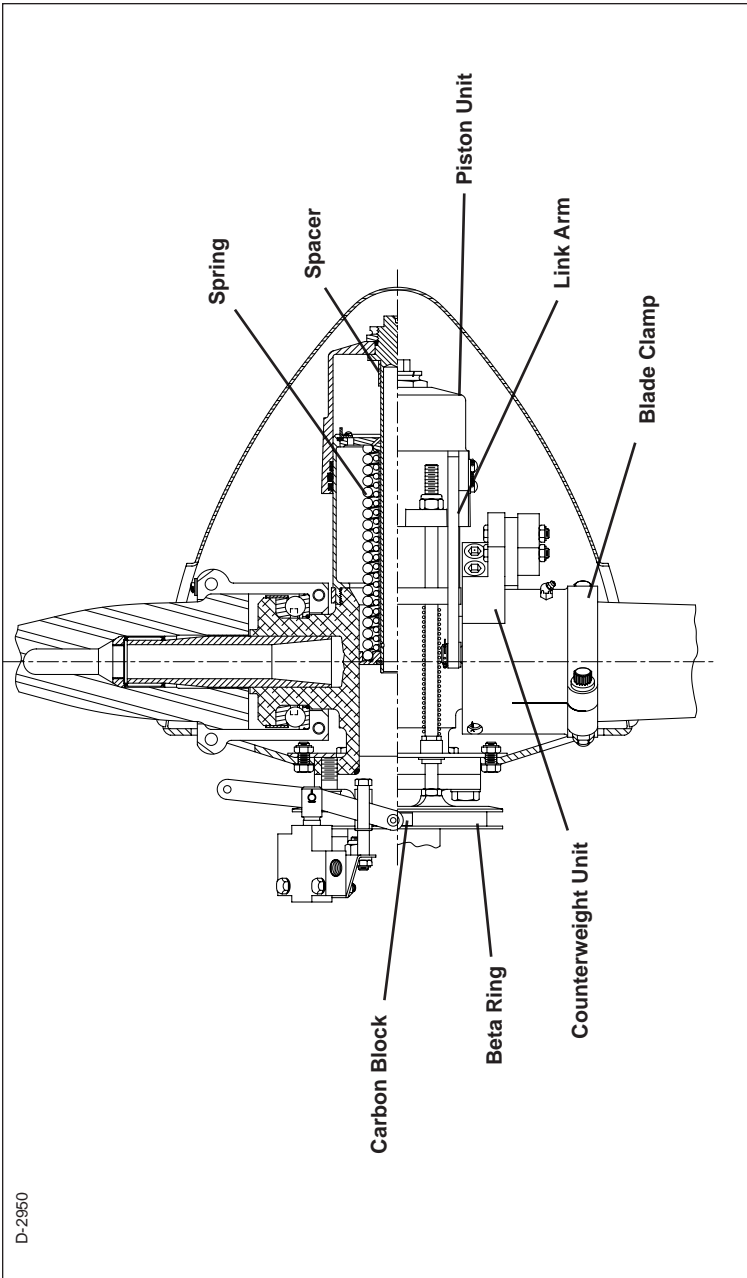

D-2950

Constant Speed and Reversing Propeller Assembly (External Beta System)
Figure 2-12

F. Constant Speed and Reversing Propellers (External Beta System)

Propeller models BHC-A2(MV,V)F-3, HC-A2(MV,V)20-3L, HC-A3(MV,V)F-3L and HC-A3(MV,V)20-3L

Refer to Figure 2-12.

A constant speed and reversing propeller is typically used on a single engine amphibian aircraft or aircraft on floats.

Propeller blade angle change is actuated by a hydraulic piston/cylinder combination mounted on the forward end of the propeller hub. The linear motion of the hydraulic piston is transmitted to each blade through a link arm system connected to a blade clamp that rotates with the blade. Each blade is retained on the propeller hub by a blade clamp and thrust bearing. The thrust bearing allows the blade to change angle.

Propeller forces consisting of mechanical spring action, counterweight twisting moment, and centrifugal and aerodynamic twisting moment of the blades in various combinations are constantly present while the propeller is operating. The summation of these forces causes the propeller to rotate to a higher pitch. A variable hydraulic force (oil under pressure from the engine driven governor) toward a lower blade pitch opposes the summation of these forces. Oil is metered by the governor to oppose these constant forces and maintain a constant engine RPM.

The forces of the installed spring and counterweight attempt to rotate the blades to a higher blade angle.

The counterweight is a weight that is attached to each blade clamp to cause the blade to rotate to a higher blade angle.

The weight of each propeller blade when spinning, generates centrifugal force and a twisting force that attempts to rotate each blade to a lower blade angle.

Air flow around the blade generates lift and an aerodynamic twisting moment that attempts to increase or decrease blade angle, depending on flight condition and blade design. This force is generally very small in relation to the other forces.

The governor uses an internal pump that is driven by an accessory drive from the engine. This pump uses an engine oil supply and increases the engine oil pressure for supply to the propeller. Engine speed sensing hardware within the governor controls the supply of oil to, or drain of oil from the propeller, resulting in a change of blade pitch to maintain constant engine speed.

Oil pressure from the engine-driven governor is supplied to the propeller mounted hydraulic cylinder through the engine shaft and propeller hub. Increasing the oil volume within the hydraulic cylinder decreases blade angle to increase engine RPM. Decreasing the oil volume will increase blade angle to decrease engine RPM. By changing the blade angle, the governor maintains constant engine RPM (within limits), independent of the power setting.

The lowest blade angle attainable by the governor is low pitch. A beta valve hydraulically controls the low pitch stop and the blade angles between low pitch and reverse. Beta refers to the blade angle range between low pitch and full reverse blade angles.

NOTE: The beta valve is normally installed between the base of the governor and the engine.

In reverse mode of operation, the governor operates in an underspeed condition to act strictly as a source of pressurized oil, without attempting to control RPM. In this mode, the pilot input to the propeller (through cockpit controls) controls the blade angle, rather than RPM.

Fundamental elements of a reversing system include a beta valve, cockpit control cable, propeller mounted blade angle feedback mechanism (beta ring), carbon block, and a lever that interfaces between those four elements and the governor operating in underspeed (as an oil pressure source). Refer to Figure 2-11.

Propeller blade angle is moved into the beta range by manually repositioning the cockpit control to move the lever and move the beta valve spool to supply oil from the governor pump to the propeller. Propeller blade angle change or piston movement is communicated back to the beta valve through the propeller mounted beta ring, carbon block assembly, and lever. The repositioned beta valve spool will prevent oil from reaching the propeller when the desired blade angle is obtained in the beta range. Any additional unwanted movement of the propeller toward reverse will cause the beta valve to drain oil from the propeller to slightly increase pitch. Any unwanted movement toward higher pitch will cause the beta valve to pump oil to the propeller to slightly decrease pitch. Thus, movement of the cockpit control in one direction will move blade angles below low pitch and toward reverse pitch, and movement in the opposite direction will move blade angles back toward low pitch blade angle.

NOTE: Blade angle may be moved into beta only when the governor is in an underspeed condition, supplying oil to the propeller.

The blade angle selection by the cockpit control must be moved to the low pitch position before the engine is shut off. Otherwise, the reversing mechanism as shown in Figure 2-11 may be damaged when the internal propeller forces move the blades to a high blade angle above low pitch, even though the reversing linkage is still set for operation in the beta blade angle range.

If oil supply is lost during flight, the propeller will go to high pitch. This occurs because the spring and blade clamp mounted counterweight forces are no longer opposed by hydraulic oil pressure and are free to increase blade pitch to the high pitch stop.

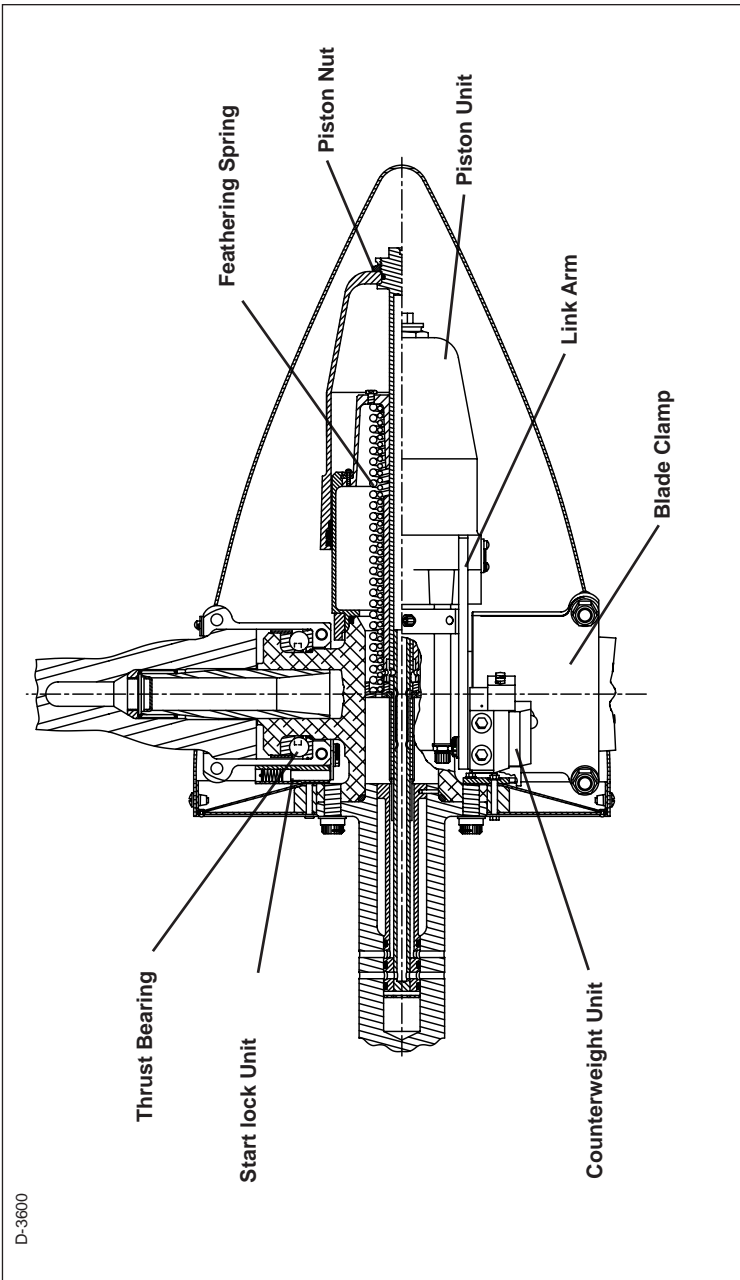

D-3600

**Constant Speed, Feathering and Reversing Propeller Assembly (Internal Beta System)
Figure 2-13**

G. Constant Speed, Feathering and Reversing Propellers
(Internal Beta System)

Propeller models HC-A3MVF-5A(L)

Refer to Figure 2-13.

A constant speed, feathering and reversing propeller is typically used on a twin engine aircraft. It is counterweighted and uses internal and external reversing control hardware.

Propeller blade angle change is actuated by a hydraulic piston/cylinder combination mounted on the forward end of the propeller hub. The linear motion of the hydraulic piston is transmitted to each blade through a link arm system connected to a blade clamp that rotates with the blade. Each blade is retained on the propeller hub by a blade clamp and thrust bearing. The thrust bearing allows the blade to change angle.

Propeller forces consisting of mechanical spring action, counterweight twisting moment, and centrifugal and aerodynamic twisting moment of the blades in various combinations are constantly present while the propeller is operating. The summation of these forces causes the propeller to rotate to a higher pitch. A variable hydraulic force (oil under pressure from the engine driven governor) toward a lower blade pitch opposes the summation of these forces. Oil is metered by the governor to oppose these constant forces and maintain a constant engine RPM.

The forces of the installed spring and counterweight attempt to rotate the blades to a higher blade angle.

The counterweight is a weight that is attached to each blade clamp to cause the blade to rotate to a higher blade angle.

The weight of each propeller blade when spinning, generates centrifugal force and a twisting force that attempts to rotate each blade to a lower blade angle.

Air flow around the blade generates lift and an aerodynamic twisting moment that attempts to increase or decrease blade angle, depending on flight condition and blade design. This force is generally very small in relation to the other forces.

The governor uses an internal pump that is driven by an accessory drive from the engine. This pump uses an engine oil supply and increases the engine oil pressure for supply to the propeller. Engine speed sensing hardware within the governor controls the supply of oil to, or drain of oil from the propeller, resulting in a change of blade pitch to maintain constant engine speed.

Oil pressure from the engine-driven governor is supplied to the propeller mounted hydraulic cylinder through the engine shaft and propeller hub. Increasing the oil volume within the hydraulic cylinder decreases blade angle to increase engine RPM. Decreasing the oil volume will increase blade angle to decrease engine RPM. By changing the blade angle, the governor maintains constant engine RPM (within limits), independent of the throttle setting.

The lowest blade angle attainable by the governor is low pitch. An external valve and internal valve hydraulically control the low pitch stop and the blade angles between low pitch and reverse. Beta refers to the blade angle range between low pitch and full reverse blade angles.

In reverse mode of operation, the governor operates in an underspeed condition to act strictly as a source of pressurized oil, without attempting to control RPM. In this mode, the pilot input to the external valve (through cockpit controls) controls the blade angle, rather than RPM.

Fundamental elements of a reversing system include an external valve, cockpit control cable, internal valve (mounted inside the engine shaft, interfacing internally with the propeller) and hydraulic lines to connect between the governor, external valve, and engine. Refer to Figure 2-11.

The propeller blade angle must be positioned at the low pitch hydraulic stop, and the governor must be underspeeding to allow reverse blade angle operation.

Propeller blade angle is moved into the beta range by manually repositioning the cockpit control to move the lever on the external valve and move the valve spool to supply oil from the governor pump to the propeller. If this lever/cockpit control position is maintained, propeller blade angle will move to full reverse. To pause and hold at some intermediate blade angle between full reverse and low pitch, the cockpit control must be moved to a position in the middle of its travel capability. This positions the lever on the external valve to position a valve spool that will not allow the governor supplied oil to enter the propeller (decrease pitch) or propeller oil to drain to engine sump (increase pitch). Propeller blade angle is moved to a higher blade angle by repositioning the cockpit control to a position opposite that used to select reverse blade angle. This will move a lever on the external valve to position a valve spool, allowing propeller oil to drain to the engine sump and increase blade angle. If this position is maintained, blade angle will return to the low pitch stop position. The cockpit control must remain in this position for normal governor control of blade angle above low pitch blade angle and to prevent unwanted movement of blade angle below the hydraulic low pitch stop.

2. Model Designation

The following pages illustrate sample model designations for Hartzell steel hub reciprocating propeller hub assemblies and blades.

A. Steel Hub Propeller Model Identification

The propeller model number is impression stamped on the propeller hub.

B HC - A 2 MV F - 1 D1

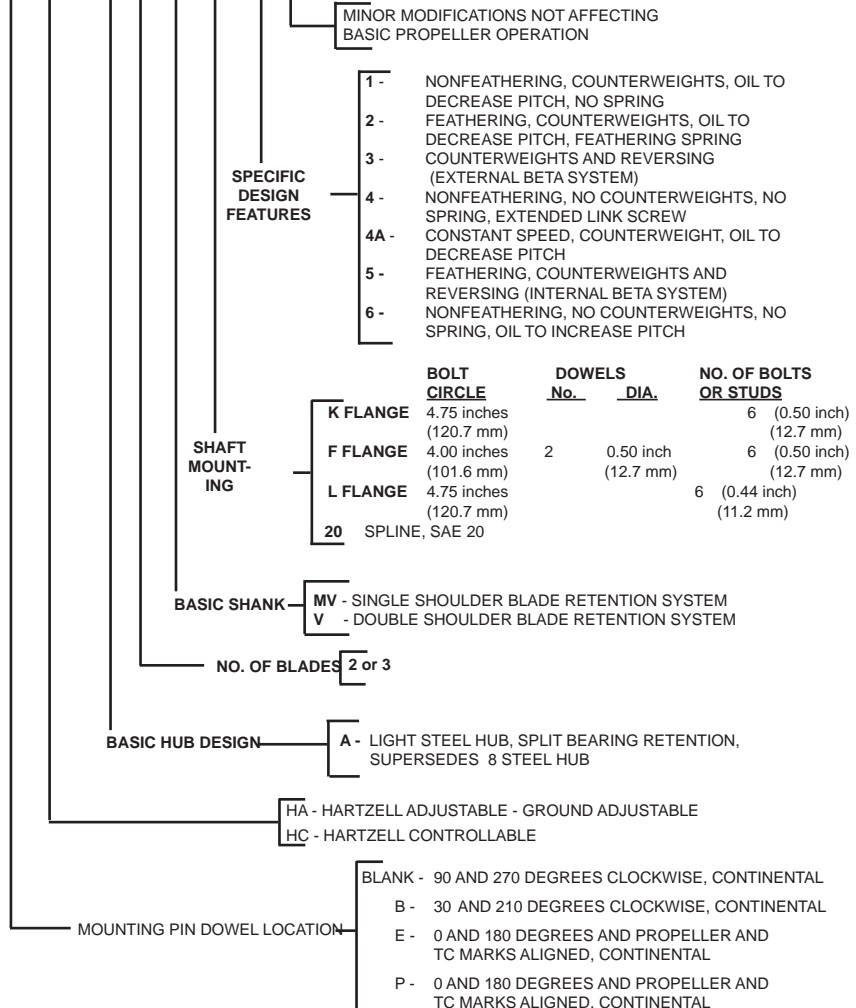

BHC-A2MVF-1D1

FLANGED:

()HC-A2(MV.V)(F.K.L)-1,-6

- 1A - DIFFERENT HUB, PISTON, SPINNER,
"A" DOWEL LOCATION, ALUMINUM DOWEL

HC-A2(MV.V)(F.K.L)-2

- A - DIFFERENT SPRING ASSEMBLY
- B - DIFFERENT SPRING ASSEMBLY,
C-2530 SPINNER, 830-12 STOP UNIT

()HC-A3MV(F.K)-2

- A - 838-1060 CLAMP ASSY.
- B - 838-1011A CLAMP ASSY.
- C - 838-1006 CLAMP ASSY.
- D - 838-1023 CLAMP ASSY.
- L - LEFT HAND ROTATION

()HC-A3V(F.K)-2

- A - 838-60 CLAMP ASSEMBLY
- B - 838-11A CLAMP ASSEMBLY
- C - 838-6 CLAMP ASSEMBLY
- D - 838-23 CLAMP ASSEMBLY
- L - LEFT HAND ROTATION

()HC-A2(MV.V)F-3

- NO MINOR MODIFICATIONS/LETTER
CHANGES

HC-A3(MV.V)F-3L

- L - LEFT HAND ROTATION

()HC-A3(MV.V)(F.K)-4

- D - DIFFERENT SPINNER

HC-A3MVF-5(A.AL)

- A - FOR LYCO GO-480, 838-1077 CLAMP ASSEMBLY, B-1457 REVERSE VALVE
- L - LEFT HAND ROTATION

HC-A3VF-5(A.AL)

- A - FOR LYCO GO-480, 838-77 CLAMP ASSEMBLY, B-1457 REVERSE VALVE
- L - LEFT HAND ROTATION

()HC-A3(MV.V)F-5R

- R - BETA RING

BHC-A2MVF-1D1

20 SPLINE:

HC-A2(MV.V)20-1

A - 834-3A GUIDE COLLAR

HA-A2(MV.V20-1B)

GROUND ADJUSTABLE BLADE PITCH
NO OIL SUPPLY NEEDED

HC-A2(MV.V20-2)

NO MINOR MODIFICATIONS/LETTER CHANGES

HC-A2(MV.V20-3L)

Feathering, reversing with beta ring

- A - FOR LYC GO480 ENGINE, A-4117 REVERSING VALVE ASSEMBLY
- B - FOR LYC GO435 ENGINE, A-2372 REVERSING VALVE ASSEMBLY
- L - LEFT HAND ROTATION

HC-A3MV20-1

- A - OBSOLETE, REPLACED BY -1B
- B - A-50-3 CONE
- C - OBSOLETE, REPLACED BY -1D
- D - A-50-5 CONE
- E - A-50-5 CONE, 838-1025R CLAMP
- F - SAME AS "E" EXCEPT DIFFERENT SPINNER

HC-A3V20-1

- A - OBSOLETE, REPLACED BY -1B
- B - A-50-3 CONE
- C - OBSOLETE, REPLACED BY -1D
- D - A-50-5 CONE
- E - A-50-5 CONE, 838-25R CLAMP
- F - SAME AS "E" EXCEPT DIFFERENT SPINNER

HC-A3MV20-2

- 2 (With 8433 blades) 838-1006 Clamps,
830-5 Stops
- 2 (With 9333 blades) 838-1023 Clamps
- 2 (With 9333CH blades) 838-1023 Clamps, 830-18 Stops
- A - NO STOPS
- L - LEFT HAND ROTATION

HC-A3V20-2

- 2 (With 8433 blades) 838-6 Clamps,
830-5 Stops
- 2 (With 9333 blades) 838-23 Clamps
- 2 (With 9333CH blades) 838-23 Clamps, 830-18 Stops
- A - NO STOPS
- L - LEFT HAND ROTATION

HC-A3(MV.V)20-3L

Feathering, reversing with beta ring

- L - LEFT HAND ROTATION

B. Aluminum Blade Model Identification

Hartzell uses a model designation to identify specific blade assemblies. Example: BHC-A2MVF-1A/MV8433N-2. A slash mark separates the propeller and blade model designations. The blade model designation is impression stamped on the blade butt end (internal) and is either on a decal or ink stamped on the blade camber side (external).

prop model/ MV 84 33 N - 2

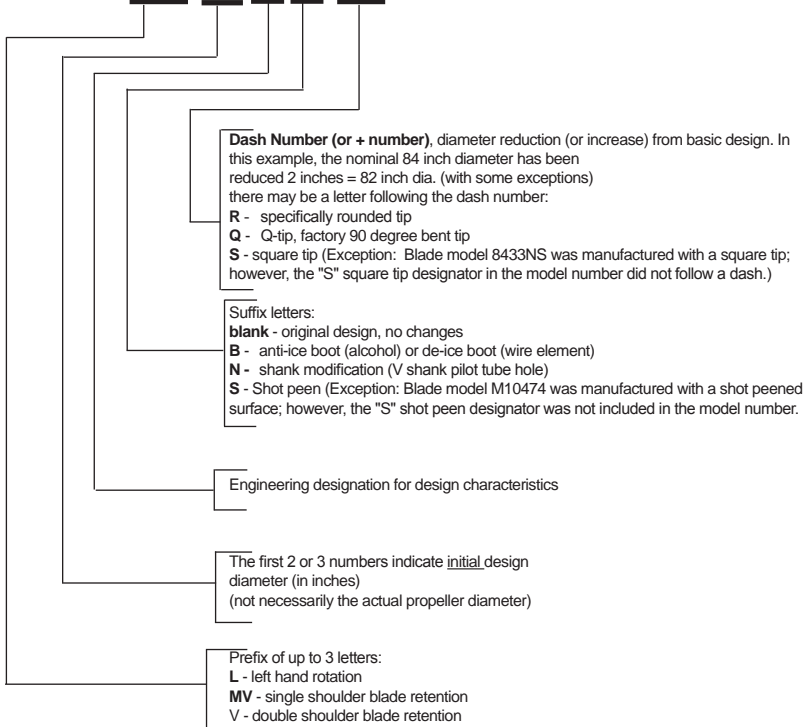

C. Conversion From V Shank to MV Shank

"V" shank models, which have double-shoulder configuration, have additional repetitive inspections required by Airworthiness Directive 97-18-02.

"MV" shank models, which have a single-shoulder configuration, are not affected by the subject Airworthiness Directive.

"V" shank blades can be converted to "MV" shank to avoid the inspections required by the Airworthiness Directive. After conversion, the propeller model number changes to reflect the conversion. For example, HC-A2V20-1/V8433N becomes HC-A2MV20-1/MV8433N.

AD 97-18-02 does not apply to ()HC-A()MV()-() propellers. These propellers are equipped with "MV" blade shank retention systems.

(This page is intentionally blank.)

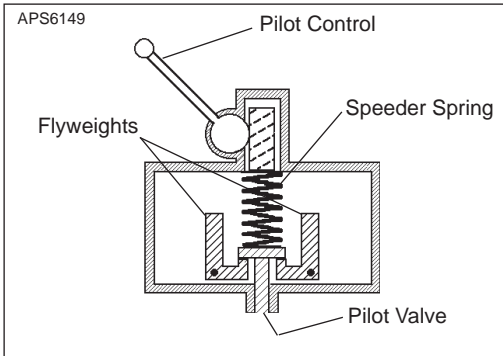

Governor in Onspeed Condition
Figure 2-14

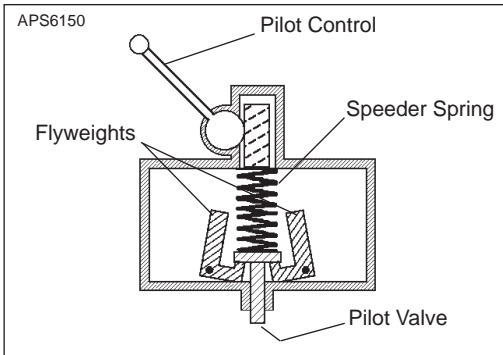

Governor in Underspeed Condition
Figure 2-15

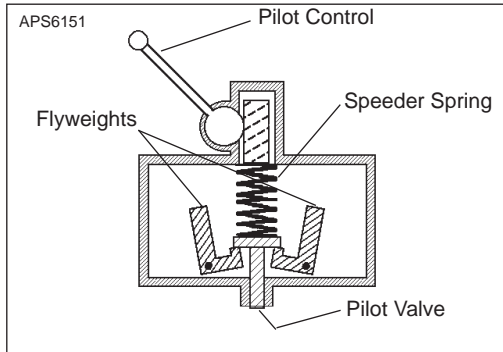

Governor in Overspeed Condition
Figure 2-16

3. Governors

A. Theory of Operation

- (1) A governor is an engine RPM sensing device and high pressure oil pump. In a constant speed propeller system, the governor responds to a change in engine RPM by directing oil under pressure to the propeller hydraulic cylinder or by releasing oil from the hydraulic cylinder. The change in oil volume in the hydraulic cylinder changes the blade angle and maintains the propeller system RPM to the set value. The governor is set for a specific RPM via the cockpit propeller control that compresses or releases the governor speeder spring.
- (2) When the engine is operating at the RPM set by the pilot using the cockpit control, the governor is operating **onspeed**. Refer to Figure 2-14. In an onspeed condition, the centrifugal force acting on the flyweights is balanced by the speeder spring, and the pilot valve is neither directing oil to nor from the propeller hydraulic cylinder.
- (3) When the engine is operating below the RPM set by the pilot using the cockpit control, the governor is operating **underspeed**. Refer to Figure 2-15. In an underspeed condition, the flyweights tilt inward because there is not enough centrifugal force on the flyweights to overcome the force of the speeder spring. The pilot valve, forced down by the speeder spring, meters oil flow to decrease propeller pitch and raise engine RPM.
- (4) When the engine is operating above the RPM set by the pilot using the cockpit control, the governor is operating **overspeed**. Refer to Figure 2-16. In an overspeed condition, the centrifugal force acting on the flyweights is greater than the speeder spring force. The flyweights tilt outward, and raise the pilot valve. The pilot valve then meters oil flow to increase propeller pitch and lower engine RPM.

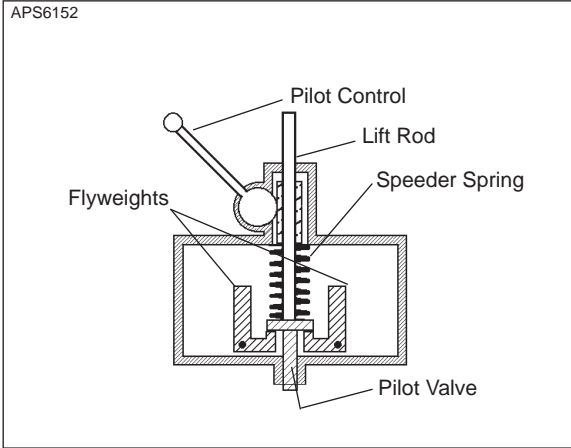

Feathering Governor
Figure 2-17

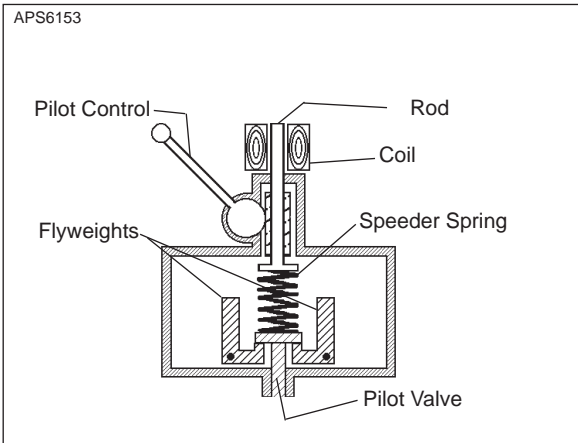

Synchronizer/Synchrophaser Governor
Figure 2-18

- (5) Refer to Figure 2-17. This figure illustrates a feathering propeller governor. This governor is similar to the constant speed governors illustrated in Figures 2-14 through 2-16, with the addition of the lift rod. When it is desired to feather the propeller, the lift rod may be moved by the cockpit control to mechanically engage the pilot valve to lift the valve. The lifted pilot valve dumps oil to increase propeller pitch until the propeller feathers.
- (6) Refer to Figure 2-18. This figure illustrates a governor as a component of a synchronizing or synchrophasing system. A synchronizing system is employed in a multi-engine aircraft to keep the engines operating at the same RPM. A synchrophasing system not only keeps RPM of the engines consistent, but also keeps the propeller blades operating in phase with each other. Both synchronizing and synchrophasing systems serve to reduce noise and vibration.
- (7) A Hartzell synchronizing or synchrophasing system uses one engine (the master engine) as an RPM and phase reference and adjusts the RPM of the remaining engine(s) (slave engine[s]) to match it. The RPM of the master engine is monitored electronically, and this information is used to adjust the voltage applied to the electrical coil on the slave governor(s). The voltage to the coil either raises or lowers a rod, which changes the force on the speeder spring. In this manner, engine RPM and phase of the propellers is synchronized or synchrophased.

B. Governor Types

The governors used in Hartzell Constant Speed propeller systems are supplied either by Hartzell or other manufacturers. These governor types function in a similar manner.

C. Identification of Hartzell Governors

Hartzell governor may be identified by model number as follows: Example F-6-4

(X) - (X) - (X)

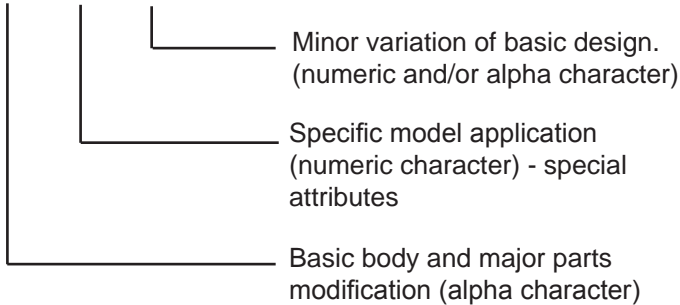

NOTE: Refer to Hartzell Manual 130B (61-23-30) for maintenance and overhaul instructions for Hartzell governors.

4. Propeller Ice Protection Systems

Some Hartzell propellers may be equipped with an anti-ice or a de-ice system. A short description of each of these systems follows:

A. Propeller Anti-Ice System

A propeller anti-ice system prevents ice from forming on propeller surfaces. The system dispenses a liquid (usually isopropyl alcohol) that mixes with moisture on the propeller blades, reducing the freezing point of the water. This water/alcohol mixture flows off the blades before ice forms. This system must be in use before ice forms. It is ineffective in removing ice that has already formed.

(1) System Overview

- (a) A typical anti-ice system consists of a fluid tank, pump, and distribution tubing.
- (b) The rate at which the anti-icing fluid is dispensed is controlled by a pump speed rheostat in the cockpit.
- (c) The anti-icing fluid is dispensed through airframe mounted distribution tubing and into a rotating slinger ring mounted on the rear of the propeller hub. The anti-icing fluid is then directed through blade feed tubes from the slinger ring onto the blades via centrifugal force. The anti-icing fluid is directed onto anti-icing boots that are attached to the leading edge of the blade. These anti-icing boots evenly distribute and direct the fluid along the blade leading edge.

B. Propeller De-Ice System

A propeller de-ice system is a system that allows ice to form, and then removes it by electrically heating the de-ice boots. The ice partially melts and is thrown from the blade by centrifugal force.

(1) System Overview

- (a) A de-ice system consists of one or more on/off switches, a timer or cycling unit, a slip ring, brush blocks, and de-ice boots. The pilot controls the operation of the de-ice system by turning on one or more switches. All de-ice systems have a master switch, and may have another toggle switch for each propeller. Some systems also have a selector switch to adjust for light or heavy icing conditions.
- (b) The timer or cycling unit determines the sequence of which blades (or portion thereof) are currently being de-iced, and for what length of time. The cycling unit applies power to each de-ice boot or boot segment in a sequential order.
- (c) A brush block, which is normally mounted on the engine just behind the propeller, is used to transfer electricity to the slip ring. The slip ring rotates with the propeller and provides a current path to the blade de-ice boots.
- (d) De-ice boots contain internal heating elements. These boots are securely attached to the leading edge of each blade with adhesive.

<u>CONTENTS</u>		<u>Page</u>
1. Tools, Consumables, and Expendables		3-7
A. Tooling.....		3-7
B. Consumables		3-8
C. Expendables		3-8
2. O-ring and Propeller Mounting Hardware Identification.....		3-10
3. Pre-Installation.....		3-15
A. Inspection of Shipping Package.....		3-15
B. Uncrating.....		3-15
C. Inspection after Shipment		3-15
D. Reassembly of a Propeller Disassembled for Shipment..		3-15
4. Propeller Assembly Installation.....		3-16
A. Precautions		3-16
B. O-ring and Propeller Mounting Hardware Identification		3-16.1
C. Installing F Flange Propeller Models (B)HC-A2(MV,V)F-1()		3-19
D. Installing K and L Flange Propeller Models HC-A2(MV,V)(K,L)-1() and HC-A2(MV,V)L-6F		3-27
E. Installing F Flange Propeller Models HC-A2(MV,V)F-2()		3-33
F. Installing K and L Flange Propeller Models HC-A2(MV,V)(K,L)-2		3-39
G. Installing F Flange Propeller Models (E,P)HC-A3(MV,V)F-2() except those using a spacer as specified in paragraph 4.H		3-45
H. Installing the EHC-A3(MV,V)F-2B Propeller using a spacer as installed on, but not limited to, the Beech 95-55, -A55, -B55, Colemill Baron Aircraft Engines, and Aero Commander Aircraft.....		3-51
I. Installing K Flange Propeller Models HC-A3(MV,V)K-2()()		3-57
J. Installing F Flange Propeller Models BHC-A2(MV,V)F-3.....		3-63

CONTENTS**Page**

K. Installing F Flange Propeller Models HC-A3(MV,V)F-3L	3-75
L. Installing F Flange Propeller Models (E,P)HC-A3(MV,V)F-4()	3-87
M. Installing K Flange Propeller Models HC-A3(MV,V)K-4.....	3-91
N. Installing F Flange Propeller Models HC-A3(MV,V)F-5A(L)	3-97
O. Installing F Flange Propeller Models (P)HC-A3(MV,V)F-5R	3-101
P. Installing Splined Propeller Models HA-A2(MV,V)20-1B	3-111
Q. Installing the 20 Spline Propeller Models HC-A2(MV,V)20-1A.....	3-119
R. Installing Splined Propeller Models HC-A3(MV,V)20-1().....	3-125
S. Installing Splined Propeller Models HC-A2(MV,V)20-2 and HC-A3(MV,V)20-2().....	3-133
T. Installing the 20 Splined Propeller Models HC-A2(MV,V)20-3L and HC-A3(MV,V)20-3L.....	3-143
5. Post-Installation Checks	3-150
6. Propeller Assembly Removal.....	3-151
A. Removing the F Flange Propeller Models (B)HC-A2(MV,V)F-1().....	3-151
B. Removing the K and L Flange Propeller Models HC-A2(MV,V)(K,L)-1() and HC-A2(MV,V)L-6F..	3-153
C. Removing the F Flange Propeller Models HC-A2(MV,V)F-2().....	3-156
D. Removing the K and L Flange Propeller Models HC-A2(MV,V)(K,L)-2().....	3-159
E. Removing the F Flange Propeller Models (E,P)HC-A3(MV,V)F-2() except those using a spacer as specified in paragraph 6.F.....	3-163

<u>CONTENTS</u>	<u>Page</u>
F. Removing the EHC-A3(MV,V)F-2B Propeller using a spacer as installed on, but not limited to, the Beech 95-55, -A55, -B55, Colemill Baron Aircraft Engines, and Aero Commander Aircraft.....	3-167
G. Removing the K Flange Propeller Models HC-A3(MV,V)K-2() ().....	3-169
H. Removing the F Flange Propeller Models BHC-A2(MV,V)F-3.....	3-172
I. Removing F Flange Propeller Models HC-A3(MV,V)F-3L	3-175
J. Removing F Flange Propeller Models (E,P)HC-A3(MV,V)F-4().....	3-178
K. Removing K Flange Propeller Models HC-A3(MV,V)K-4.....	3-181
L. Removing F Flange Propeller Models HC-A3(MV,V)F-5A(L)	3-184
M. Removing F Flange Propeller Models (P)HC-A3(MV,V)F-5R.....	3-187
N. Removing the 20 Splined Propeller Model HA-A2(MV,V)20-1B	3-191
O. Removing the 20 Splined Propeller Models HC-A2(MV,V)20-1A	3-194
P. Removing the 20 Splined Propeller Models HC-A3(MV,V)20-1().....	3-197
Q. Removing the 20 Splined Propeller Models HC-A2(MV,V)20-2 and HC-A3(MV,V)20-2()	3-200
R. Removing the 20 Splined Propeller Models HC-A2(MV,V)20-3L and HC-A3(MV,V)20-3L.....	3-204

	<u>FIGURES</u>	<u>Page</u>
(B)HC-A2(MV,V)(F,K,L)-1() Propeller Assembly	Figure 3-1	3-17
F Flange Installation on -1() Propeller Models	Figure 3-2	3-18
Installing F Flange Propeller on the Engine Flange	Figure 3-3	3-20
Determining Torque Value When Using Torquing Adapter	Figure 3-4	3-21
K and L Flange Installations on -1(), -4, and -6F Propeller Models	Figure 3-5	3-26
Installing K or L Flange Propeller on the Engine Flange	Figure 3-6	3-28
HC-A2(MV,V)(F,K,L)-2() Propeller Assembly	Figure 3-7	3-32
F Flange Installation on -2 Propeller Models	Figure 3-8	3-34
K and L Flange Installation on -2 Propeller Models.....	Figure 3-9	3-38
(E,P)HC-A3(MV,V)F-2()() Propeller Assembly	Figure 3-10	3-44
EHC-A3(MV,V)F-2B Mounting Parts	Figure 3-11	3-50
EHC-A3(MV,V)F-2B Installation	Figure 3-12	3-50
HC-A3(MV,V)K-2()() Propeller Assembly	Figure 3-13	3-56
BHC-A2(MV,V)F-3 Propeller Assembly ..	Figure 3-14	3-62
Tool for Decompressing External Beta System.....	Figure 3-15	3-63
Carbon Block and Beta Ring Clearance	Figure 3-16	3-66
Carbon Block Assembly.....	Figure 3-17	3-66

	<u>FIGURES</u>	<u>Page</u>
Installation of Beta Valve, Governor, and Linkage	Figure 3-18	3-67
Adjusting Propeller Reverse Control System.....	Figure 3-19	3-70
HC-A3(MV,V)F-3L Propeller Assembly...	Figure 3-20	3-74
Tool for Decompressing External Beta System.....	Figure 3-21	3-75
HC-A3(MV,V)F-3L Installation	Figure 3-22	3-76
(E,P)HC-A3(MV,V)(F,K)-4() Propeller Assembly	Figure 3-23	3-86
HC-A3(MV,V)F-5A(L) Propeller Assembly	Figure 3-24	3-96
(P)HC-A3(MV,V)F-5R Propeller Assembly	Figure 3-25	3-100
(P)HC-A3(MV,V)F-5R Installation	Figure 3-26	3-101
HA-A2(MV,V)20-1B Propeller Assembly	Figure 3-27	3-110
Piston-to-Link Arm Attachment Details ...	Figure 3-28	3-111
Pitch Adjustment Assembly-to-Cylinder Attachment Details	Figure 3-29	3-112
Rear Hub Mounting Parts on HA-A2(MV,V)20-1B Propeller	Figure 3-30	3-114
Safetying the Shaft Nut on the 20 Spline Shaft Propeller.....	Figure 3-31	3-114
Installing Piston O-Ring and Felt Dust Seal	Figure 3-32	3-115
HC-A2(MV,V)20-1A Propeller Assembly.	Figure 3-33	3-118
HC-A3(MV,V)20-1() Propeller Assembly	Figure 3-34	3-124

	<u>FIGURES</u>	<u>Page</u>
Rear Hub Mounting Parts on HC-A3(MV,V)20-1() Propeller	Figure 3-35	3-126
HC-A2(MV,V)20-2 Propeller Assembly	Figure 3-36	3-131
HC-A3(MV,V)20-2() Propeller Assembly	Figure 3-37	3-132
Spring Assembly-to-Cylinder Attachment Details.....	Figure 3-38	3-134
Rear Hub Mounting Parts	Figure 3-39	3-135
Guide Rod Attachment Details	Figure 3-40	3-138
HC-A2(MV,V)20-3L Propeller Assembly .	Figure 3-41	3-141
HC-A3(MV,V)20-3L Propeller Assembly .	Figure 3-42	3-142
Rear Hub Mounting Parts on HC-A(2,3)(MV,V)20-3L Propeller	Figure 3-43	3-145
Information Tag on Beta Return Spring ..	Figure 3-44	3-148
Spinner Bulkhead Removal	Figure 3-45	3-164

	<u>TABLES</u>	<u>Page</u>
O-ring and Propeller Mounting Hardware Identification	Table 3-1	3-10
Torque Table	Table 3-2	3-22

1. Tools, Consumables, and Expendables

The steel hub reciprocating propellers covered in this manual are manufactured with either a flange mounting or a spline mounting. The flange type or spline type used on a particular propeller installation is indicated in the propeller model identification number stamped on the hub. For example, HC-A3MVE-2B indicates an "F" flange. HC-A3MV**20**-2 indicates a "20" spline. Refer to the Steel Hub Model Identification in the Description and Operation chapter of this manual for a description of each flange type.

The flange mounted propeller is shipped completely assembled. The spline mounted propeller is shipped with the piston removed.

The following tools, consumables, and expendables will be required for propeller removal or installation:

A. Tooling

NOTE: The use of torque wrench adapters for F and K flange installations will vary according to specific application.

F Flange

- Safety wire pliers (Alternate safety cable tool)
- Calibrated torque wrench
- Torque wrench adapter, Hartzell P/Ns AST-2917, AST-2805, or a locally procured torque wrench adapter of the appropriate size

K Flange

- Safety wire pliers (Alternate safety cable tool)
- Calibrated torque wrench
- Torque wrench adapter, Hartzell P/N AST-2805 or a locally procured torque wrench adapter of the appropriate size

L Flange

- Safety wire pliers (Alternate safety cable tool)
- Calibrated torque wrench
- Locally procured torque wrench adapter of the appropriate size

20 Spline

- Shaft nut wrench Hartzell P/N BST-2910

B. Consumables

- Quick Dry Stoddard Solvent or Methyl-Ethyl-Ketone (MEK)
- Anti-Seize Compound (MIL-PRF-83483)

C. Expendables

- 0.032 inch (0.81 mm) Stainless steel Aircraft Safety wire (Alternate: 0.032 inch [0.81 mm] aircraft safety cable and associated hardware)
- O-rings (see Table 3-1)

(This page is intentionally blank.)

2. O-ring and Propeller Mounting Hardware Identification

Part	Propeller Model	Part No.
Cone, Rear	HC-A2(MV,V)20-1A	A-50-3
	HA-A2(MV,V)20-1B	A-50-1
	HC-A2(MV,V)20-2	A-50-3
	HC-A2(MV,V)20-3L	A-50-1
	HC-A3(MV,V)20-1B	A-50-3
	HC-A3(MV,V)20-1(D,E,F)	A-50-5
	HC-A3(MV,V)20-2(L)	A-50-3
	HC-A3(MV,V)20-3L	A-50-1
	Dowel Pin	(B)HC-A2(MV,V)F-1()
HC-A2(MV,V)F-2()		B-6138-8-8
BHC-A2(MV,V)-3		B-6138-8-8
()HC-A3(MV,V)F-2()		B-6138-8-8
HC-A3(MV,V)F-3L		B-6138-8-8
()HC-A3(MV,V)F-4()		B-6138-8-8
()HC-A3(MV,V)F-5A()		B-6138-8-8
Felt Dust Seal		HA-A2(MV,V)20-1B
	HC-A2(MV,V)20-1A	B-1843
	HC-A2(MV,V)20-2	B-1843
	HC-A2(MV,V)20-3L	B-1843
	HC-A3(MV,V)20-1()	B-1843
	HC-A3(MV,V)20-2()	B-1843
	HC-A3(MV,V)20-3L	B-1843
Mounting Bolt/Stud	(B)HC-A2(MV,V)K-1()	A-1333-3
	(B)HC-A2(MV,V)L-1()	B-322
	HC-A2(MV,V)F-2()	A-1328-1
	HC-A2(MV,V)L-2	B-6489-25 (4)
		B-6489-20 (2)
	BHC-A2(MV,V)F-3	A-1328-1
	(B)HC-A2(MV,V)F-1()	A-1328-1
	HC-A2(MV,V)K-2()	A-1333 (2)
		A-1333-3, ALT (2)
		A-1328 (4)
	HC-A2(MV,V)L-6F	B-322
	HC-A3(MV,V)K-2()L	A-1328 (4)
		A-1333-3 (2)
	(P)HC-A3(MV,V)F-2()	A-1328-1
	EHC-A3(MV,V)F-2B	A-1328-2
	HC-A3(MV,V)F-3L	A-2983 STUD
	HC-A3(MV,V)F-5A(L)	A-1328-1
	HC-A3(MV,V)F-5R	A-2983 STUD
	PHC-A3(MV,V)F-5R	A-2983-2 STUD
	(E,P)HC-A3(MV,V)F-4()	A-1328-2
HC-A3(MV,V)K-4	A-1333-3	

**O-ring and Propeller Mounting Hardware Identification
Table 3-1**

Part	Propeller Model	Part No.
Nut, Piston Rod	HC-A2(MV,V)20-2	B-3368
	(E,P)HC-A3(MV,V)F-2()	B-3368
	HC-A3(MV,V)K-2()	B-3368
	HC-A3(MV,V)F-4()	B-3368
	HC-A3(MV,V)K-4	B-3368
	HC-A3(MV,V)F-5A()	B-3368
	(P)HC-A3(MV,V)20-2()	B-3368
Nut, Fork Rod	(B)HC-A2(MV,V)F-1A	A-848-2
	HC-A2(MV,V)K-1	A-848-2
	HC-A2(MV,V)L-1	A-848-2
	HC-A2VL-6F	A-848-2
	HC-A3(MV,V)20-1()	A-848-2
Nut, Pitch change	BHC-A2(MV,V)F-3	A-880-2
	HA-A2(MV,V)20-1B	A-880-1
	HC-A2(MV,V)20-2	A-880-1
	HC-A2(MV,V)20-3L	A-880-1
	(E,P)HC-A3(MV,V)F-2()	A-880-2
	HC-A3(MV,V)K-2()	A-880-2
	HC-A3(MV,V)F-3L	A-880-2
	HC-A3(MV,V)F-5A()	A-880-1
	PHC-A3(MV,V)F-5R	A-880-1
	HC-A3(MV,V)20-2()	A-880-1
HC-A3(MV,V)20-3L	A-880-1	
Nut, Shaft/Hub and Puller Ring	HC-A2(MV,V)20-1A	A-63-B + A-870
	HA-A2(MV,V)20-1B	A-63-B + A-870
	HC-A2(MV,V)20-2	A-63-B + A-870
	HC-A2(MV,V)20-3L	A-63-B + A-870
	HC-A3(MV,V)20-1()	A-63-B + A-870
	HC-A3(MV,V)20-2()	A-63-B + A-870
	HC-A3(MV,V)20-3L	A-63-B + A-870
Nut, Mounting Stud	EHC-A3(MV,V)F-2B	A-2044
	HC-A3(MV,V)F-3L	A-2044

**O-ring and Propeller Mounting Hardware Identification
Table 3-1, Continued**

Part	Propeller Model	Part No.
O-ring, Shaft/Engine Flange	(B)HC-A2(MV,V)F-1()	C-3317-228
	(B)HC-A2(MV,V)(K,L)-1()	C-3317-329
	HC-A2(MV,V)F-2()	C-3317-228
	HC-A2(MV,V)(K,L)-2()	C-3317-329
	BHC-A2(MV,V)F-3	C-3317-228
	HC-A2(MV,V)L-6F	C-3317-329
	(E,P)HC-A3(MV,V)F-2()	C-3317-228
	HC-A3(MV,V)F-3L	C-3317-228
	(P)HC-A3(MV,V)F-5R	C-3317-228
	HC-A3(MV,V)F-5A()	C-3317-228
	(E,P)HC-A3(MV,V)F-4()	C-3317-228
	(E,P)HC-A3(MV,V)K-2()	C-3317-329
	(E,P)HC-A3(MV,V)K-4()	C-3317-329
	O-ring, Propeller Side (for use with B-2982 spacer)	EHC-A3(MV,V)F-2B
O-ring, Propeller Mounting	EHC-A3(MV,V)F-2B	C-3317-228
O-ring, Piston	HA-A2(MV,V)20-1B	C-3317-343-1
	HC-A2(MV,V)20-1A	C-3317-343-1
	HC-A2(MV,V)20-2	C-3317-343-1
	HC-A2(MV,V)20-3L	C-3317-343-1
	HC-A3(MV,V)20-1()	C-3317-343-1
	HC-A3(MV,V)20-2()	C-3317-343-1
	HC-A3(MV,V)20-3L	C-3317-343-1
O-ring, Rear Cone	HA-A2(MV,V)20-1B	C-3317-229
	HC-A2(MV,V)20-1A	C-3317-229
	HC-A2(MV,V)20-2	C-3317-229
	HC-A2(MV,V)20-3L	C-3317-229
	HC-A3(MV,V)20-1()	C-3317-229
	HC-A3(MV,V)20-2(L)	C-3317-229
	HC-A3(MV,V)20-3L	C-3317-229
O-ring, Rod	HA-A2(MV,V)20-1B	C-3317-020
	HC-A2(MV,V)20-2	C-3317-020
	HC-A2(MV,V)20-3L	C-3317-020
	HC-A3(MV,V)20-2()	C-3317-020
	HC-A3(MV,V)20-3L	C-3317-020
Pitch Change Block	(B)HC-A2(MV,V)F-1A	A-95-A
	HC-A2(MV,V)K-1	A-95-A
	HC-A2(MV,V)L-1	A-95-A
	HC-A2(MV,V)L-6	A-95-A
	HC-A2(MV,V)20-1A	A-95-A
	HC-A3(MV,V)20-1()	A-95-A

**O-ring and Propeller Mounting Hardware Identification
Table 3-1, Continued**

Part	Propeller Model	Part No.
Plate, Spinner	BHC-A2(MV,V)F-3	C-2954
	HC-A3(MV,V)F-3L	C-3675
	HC-A3(MV,V)F-5R	C-3673
	PHC-A3(MV,V)F-5R	C-3676
Plate, Support	HC-A2(MV,V)20-3L	C-1981
	HC-A3(MV,V)20-3L	C-1958
Safety Pin, Hub Nut	HA-A2(MV,V)20-1B	A-847
	HC-A2(MV,V)20-1A	A-847
	HC-A2(MV,V)20-2	A-847
	HC-A2(MV,V)20-3L	A-847
	HC-A3(MV,V)20-1()	A-847
	HC-A3(MV,V)20-2()	A-847
	HC-A3(MV,V)20-3L	A-847
Screw, Socket Head Cap (on piston rod)	HC-A2(MV,V)20-2	A-2037
	HC-A3(MV,V)20-2()	A-2037
	(E,P)HC-A3(MV,V)F-2()	A-2037
	HC-A3(MV,V)K-2() ()	A-2037
	(P)HC-A3(MV,V)F-4()	A-2037
	HC-A3(MV,V)K-4	A-2037
	HC-A3(MV,V)F-5A()	A-2037
Shim	HC-A2(MV,V)K-1	B-1322
	HC-A2(MV,V)L-1	B-933-1
	HC-A2(MV,V)K-2	B-1322
	HC-A2(MV,V)L-2	B-933-1
	HC-A2(MV,V)L-6F	B-933-1
	HC-A3(MV,V)K-2() ()	B-1322
	HC-A3(MV,V)K-4	
Spacer, Flange	EHC-A3(MV,V)F-2B	B-2982
	HC-A3(MV,V)F-3L	B-2982
	HC-A3(MV,V)F-5R	B-2982
	PHC-A3(MV,V)F-5R	B-2984-3
Washer, Fork Rod	(B)HC-A2(MV,V)F-1A	A-965
	HC-A2(MV,V)K-1	A-965
	HC-A2(MV,V)L-1	A-965
	HC-A2(MV,V)20-1A	A-965
	HC-A2(MV,V)L-6F	A-965
	HC-A3(MV,V)20-1()	A-965

**O-ring and Propeller Mounting Hardware Identification
Table 3-1, Continued**

Part	Propeller Model	Part No.
Washer, (Mounting Bolt/Stud)	(B)HC-A2(MV,V)F-1()	A-1381
	HC-A2(MV,V)F-2()	A-1381
	HC-A2(MV,V)K-2	A-1381
	HC-A2(MV,V)L-2	B-6527-7 (4)
		(with B-6489-25 bolt)
		B-6329-7 (2)
		(with B-6489-20 bolt)
	BHC-A2(MV,V)F-3	A-1381
	(E,P)HC-A3(MV,V)F-2()	A-1381
	HC-A3(MV,V)F-3L	A-1381
	(E,P)HC-A3(MV,V)F-4()	A-1381
		A-2482-1, ALT
	HC-A3(MV,V)F-5A()	A-1381
	(P)HC-A3(MV,V)F-5R	A-1381

**O-ring and Propeller Mounting Hardware Identification
Table 3-1, Continued**

3. Pre-Installation

A. Inspection of Shipping Package

Examine the exterior of the shipping container, especially the box ends around each blade, for signs of shipping damage. A hole, tear, or crushed appearance at the end of the box (blade tips) may indicate that the propeller was dropped during shipment, possibly damaging the blades.

B. Uncrating

(1) Put the propeller on a firm support.

(2) Remove the banding and any external wood bracing, if applicable, from the shipping container.

(3) Remove the cardboard from the hub and blades. Put the propeller on a padded surface that supports the propeller over a large area. Never stand the propeller on a blade tip.

(4) On flange mounted models, remove the plastic dust cover cup from the propeller mounting flange (if installed).

C. Inspection after Shipment

After removing the propeller from the shipping container, examine the propeller components for possible shipping damage.

D. Reassembly of a Propeller Disassembled for Shipment

If a propeller was received disassembled for shipment, it must be reassembled by trained personnel in accordance with the applicable propeller maintenance manual.

4. Propeller Assembly Installation**A. Precautions**

WARNING 1: DURING ENGINE INSTALLATION OR REMOVAL, USING THE PROPELLER TO SUPPORT THE WEIGHT OF THE ENGINE IS NOT AUTHORIZED. UNAPPROVED INSTALLATION AND REMOVAL TECHNIQUES MAY CAUSE DAMAGE TO THE PROPELLER THAT MAY LEAD TO FAILURE RESULTING IN AN AIRCRAFT ACCIDENT.

WARNING 2: WHEN INSTALLING THE PROPELLER, FOLLOW THE AIRFRAME MANUFACTURER'S MANUALS AND PROCEDURES, AS THEY MAY CONTAIN ISSUES VITAL TO AIRCRAFT SAFETY THAT ARE NOT CONTAINED IN THIS OWNER'S MANUAL.

CAUTION: INSTRUCTIONS AND PROCEDURES IN THIS SECTION MAY INVOLVE PROPELLER CRITICAL PARTS. REFER TO THE INTRODUCTION CHAPTER OF THIS MANUAL FOR INFORMATION ABOUT PROPELLER CRITICAL PARTS. REFER TO THE ILLUSTRATED PARTS LIST CHAPTER OF THE APPLICABLE OVERHAUL MANUAL(S) FOR THE IDENTIFICATION OF SPECIFIC PROPELLER CRITICAL PARTS.

- (1) Be sure the propeller is removed before the engine is removed or installed in the airframe.

- (2) Follow the airframe manufacturer's instructions for installing the propeller. If such instructions are not in the airframe manufacturer's manual, then follow the instructions in this manual; however, mechanics must consider that this owner's manual does not describe important procedures that are beyond Hartzell's control. In addition to propeller installation procedures, items such as rigging and preflight testing of flight idle blade angle, installation and adjustment of de-ice equipment, and propeller synchronization devices are normally found in the airframe manufacturer's manuals.
- B. O-ring and Propeller Mounting Hardware Identification
- Refer to Table 3-1 for specific part numbers of O-rings and propeller mounting hardware, and propeller model effectivity.

(This page is intentionally blank.)

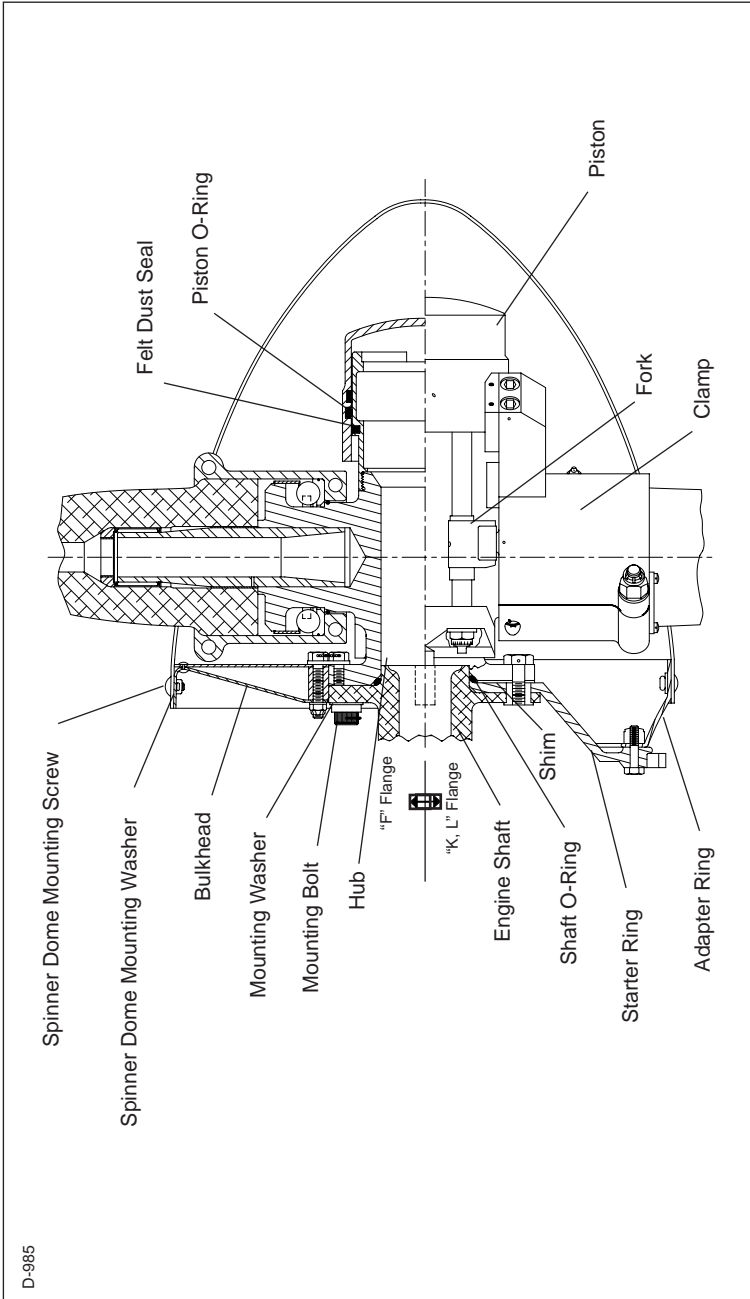

**(B)HC-A2(MV,V)(F,K,L)-1() Propeller Assembly
Figure 3-1**

D-985

D-985

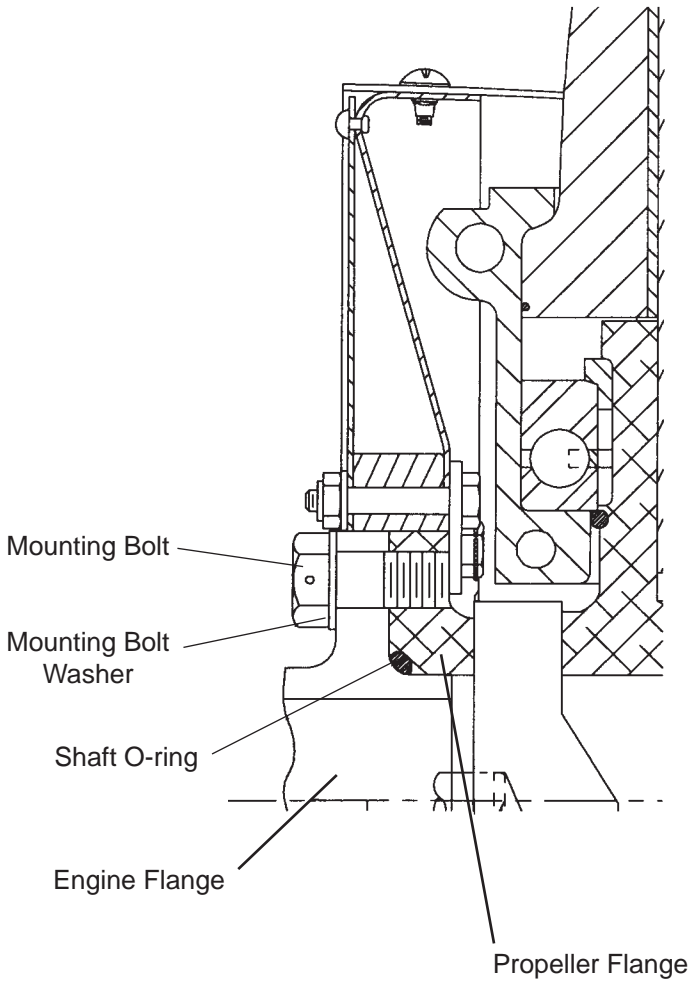

**F Flange Installation on -1() Propeller Models
Figure 3-2**

C. Installing F Flange Propeller Models
(B)HC-A2(MV,V)F-1()

Refer to Figure 3-1

CAUTION 1: INSTRUCTIONS AND PROCEDURES IN THIS SECTION MAY INVOLVE PROPELLER CRITICAL PARTS. REFER TO THE INTRODUCTION CHAPTER OF THIS MANUAL FOR INFORMATION ABOUT PROPELLER CRITICAL PARTS. REFER TO THE ILLUSTRATED PARTS LIST CHAPTER OF THE APPLICABLE OVERHAUL MANUAL(S) FOR THE IDENTIFICATION OF SPECIFIC PROPELLER CRITICAL PARTS.

CAUTION 2: INSERT THE DOWEL PINS INTO THE PROPELLER FLANGE USING A BRASS HAMMER OR EQUIVALENT TOOL TO PREVENT DAMAGE TO THE DOWEL PINS. THE DOWEL PINS ARE AN INTERFERENCE FIT WITH THE PROPELLER FLANGE.

- (1) Insert two dowel pins (Table 3-1) through the threadless holes in the propeller flange, flush with the propeller side of the hub flange. The dowel pins will protrude from the engine side of the hub flange to engage the engine flange.

WARNING: MAKE SURE THE SLING IS RATED UP TO 800 POUNDS (363 KG) TO SUPPORT THE WEIGHT OF THE PROPELLER ASSEMBLY DURING INSTALLATION.

CAUTION: WHEN INSTALLING THE PROPELLER ON THE AIRCRAFT, DO NOT DAMAGE THE ICE PROTECTION SYSTEM COMPONENTS, IF APPLICABLE.

- (2) With a suitable crane hoist and sling, carefully move the propeller assembly to the aircraft engine mounting flange in preparation for installation.

WARNING: CLEANING AGENT MEK IS FLAMMABLE AND TOXIC TO THE SKIN, EYES AND RESPIRATORY TRACT. SKIN AND EYE PROTECTION ARE REQUIRED. AVOID PROLONGED CONTACT. USE IN A WELL VENTILATED AREA.

- (3) Clean the engine flange and propeller flange with Quick Dry Stoddard Solvent or MEK.
- (4) Lubricate the specified shaft O-ring (Table 3-1) and install it on the engine shaft.

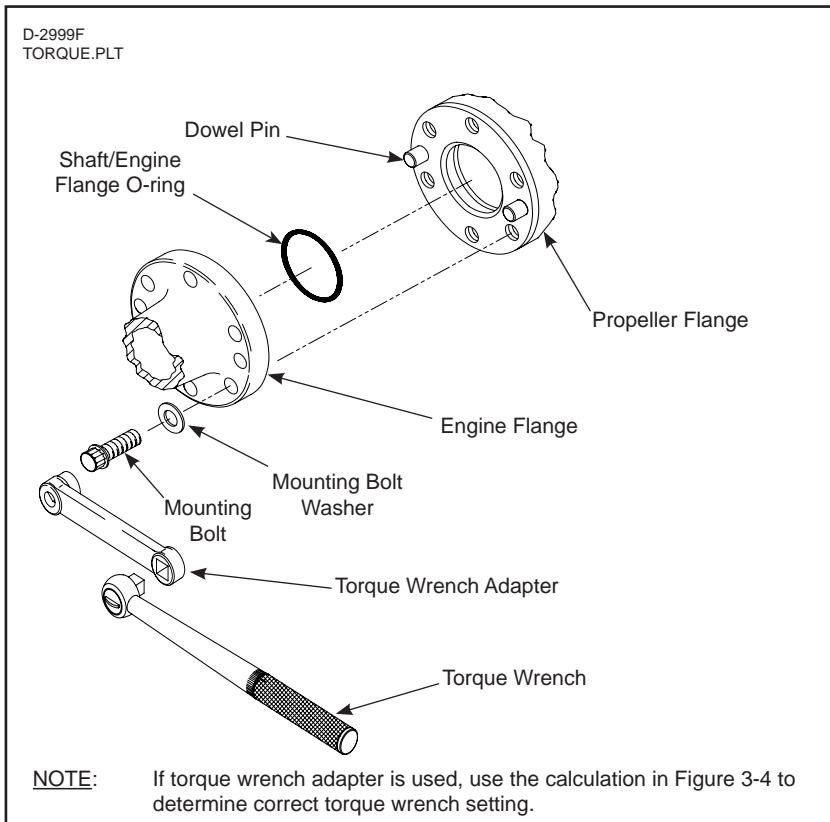

**Installing F Flange Propeller on the Engine Flange
Figure 3-3**

CAUTION: USE CARE TO AVOID SCRAPING ALUMINUM FROM THE BORE OF THE SPINNER BULKHEAD. SCRAPINGS COULD BECOME WEDGED BETWEEN THE FLANGE SURFACES.

- (5) Slide the spinner bulkhead onto the propeller flange OD.
- (6) Align the spinner bulkhead mounting holes with the holes in the four tabs that are bolted to the propeller hub.
- (7) Install the spinner bulkhead attachment bolts, washers, and self-locking hex head nuts to hold the spinner bulkhead to the hub flange mounted tabs.
- (8) Torque the spinner attachment bolts and self-locking hex head nuts to 8 to 12 Ft-Lb (11-16 N•m).
- (9) Align the mounting holes and dowel pins in the propeller hub flange with the mounting holes and the dowel pin holes in the engine flange.

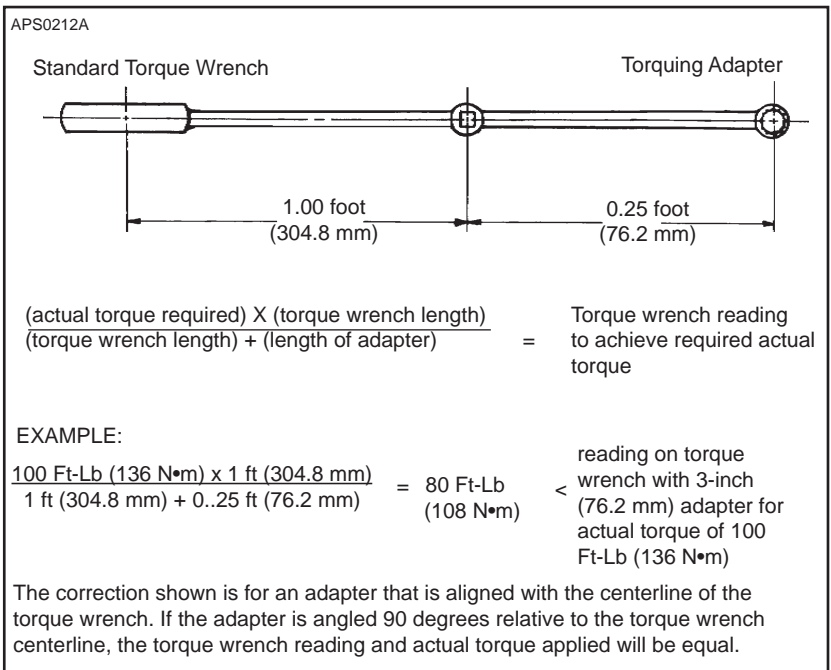

Determining Torque Value When Using Torquing Adapter
Figure 3-4

**F Flange propeller
mounting bolts**

A-1333-() 80-90 Ft-Lb (108-122 N•m)

A-1328-() 80-90 Ft-Lb (108-122 N•m)

F Flange mounting nut (on stud)

A-2044 Nut 80-90 Ft-Lb (108-122 N•m)

**K Flange propeller
mounting bolts**A-1333-() & A-1328
except on Lycoming IO-720 60-70 Ft-Lb (81-95 N•m)A-1333-() & A-1328
Lycoming IO-720 engine only 100-125 Ft-Lb (136-170 N•m)**L Flange propeller
mounting bolts**

B-322 50 Ft-Lb (68 N•m)

B-6489-() 50 Ft-Lb (68 N•m)

Shaft Nut

A-63B 450 Ft-Lb (610 N•m)

Piston Nut

A-880-() 120 Ft-Lb (163 N•m)

**Low-pitch stop nut
(on piston rod)**

A-848-2 20-22 Ft-Lb. (27-30 N•m)

A-2043-() 20-22 Ft-Lb. (27-30 N•m)

A-3359 20-22 Ft-Lb. (27-30 N•m)

B-3382 or alternate A-3439 20-22 Ft-Lb. (27-30 N•m)

NOTE 1: Torque tolerance is ± 10 percent unless otherwise noted.**NOTE 2:** Torque values are based on non-lubricated threads.**Torque Table
Table 3-2**

CAUTION 1: MAKE SURE THAT COMPLETE AND TRUE SURFACE CONTACT IS ESTABLISHED BETWEEN THE PROPELLER HUB FLANGE AND THE ENGINE FLANGE.

CAUTION 2: USE CARE TO AVOID SCRAPING ALUMINUM FROM THE BORE OF THE SPINNER BULKHEAD. SCRAPINGS COULD BECOME WEDGED BETWEEN THE FLANGE SURFACES.

(10) Slide the propeller flange onto the engine flange.

CAUTION: NEW PROPELLER MOUNTING BOLTS MUST BE USED WHEN INITIALLY INSTALLING A NEW OR OVERHAULED PROPELLER.

(11) Install the mounting bolts (Table 3-1) with washers (if applicable) through the engine flange from the engine side and into the tapped holes in the propeller flange. Refer to Figures 3-2 and 3-3.

NOTE: For propeller removals between overhaul intervals, mounting bolts and washers may be reused if they are not damaged or corroded.

(12) Use a torque wrench with the appropriate torque wrench adapter to torque all mounting bolts in sequence. Refer to Table 3-2 and Figure 3-4 to determine the proper torque value to which the torque wrench must be set.

NOTE: Refer to the Tools, Consumables, and Expendables section in this chapter for a list of applicable torque wrench adapters.

(a) Torque the mounting bolts to half of the final torque, beginning with any mounting bolt, and moving around the clock in either direction.

(b) Final torque the bolts in sequence, beginning with any mounting bolt, and moving around the clock in either direction.

(13) Safety all mounting bolts with 0.032 inch (0.81 mm) minimum diameter stainless steel wire or equivalent aircraft safety cable and associated hardware (two bolts per safety).

- (14) If the propeller is equipped with an ice protection system that uses components supplied by Hartzell Propeller Inc., applicable instructions and technical information for the components supplied by Hartzell can be found in the following publications, available on the Hartzell website at www.hartzellprop.com.
- (a) Manual 180 (30-61-80) - Propeller Ice Protection System Manual
 - (b) Manual 181 (30-60-81) - Propeller Ice Protection Component Maintenance Manual
 - (c) Manual 182 (61-12-82) - Propeller Electrical De-ice Boot Removal and Installation Manual
 - (d) Manual 183 (61-12-83) - Propeller Anti-icing Boot Removal and Installation Manual
- (15) Propeller ice protection system components not supplied by Hartzell Propeller Inc. are controlled by the applicable TC or STC holder's Instructions for Continued Airworthiness (ICA).

(16) Install the spinner dome as follows:

NOTE: The following instructions relate to Hartzell spinners only. In some cases, the airframe manufacturer produced the spinner assembly. In those cases, refer to the airframe manufacturer's manual for spinner installation instructions.

CAUTION 1: TO PREVENT DAMAGE TO THE BLADE AND BLADE PAINT, WRAP THE BLADE SHANKS IN SEVERAL LAYERS OF MASKING OR DUCT TAPE BEFORE INSTALLING THE SPINNER DOME. REMOVE THE TAPE AFTER THE SPINNER IS INSTALLED.

CAUTION 2: THE SPINNER DOME WILL WOBBLE IF NOT ALIGNED PROPERLY, AND MAY AFFECT THE BALANCE OF THE PROPELLER.

- (a) Carefully slide the spinner dome over the reinstalled propeller.
- (b) Secure the spinner dome to the spinner bulkhead with the supplied screws and washers.

D-1334

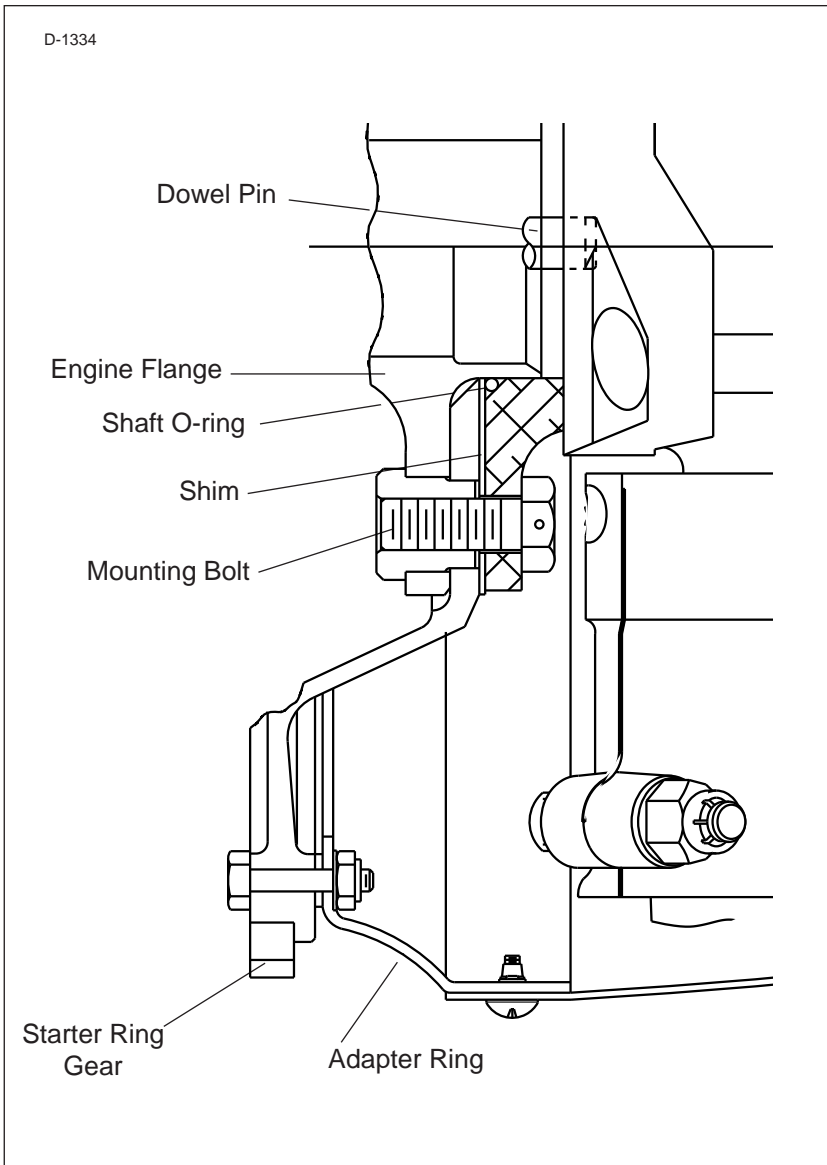

**K and L Flange Installations on -1(), -4, and -6F Propeller Models
Figure 3-5**

- D. Installing K and L Flange Propeller Models
HC-A2(MV,V)(K,L)-1() and HC-A2(MV,V)L-6F
Refer to Figure 3-1.

WARNING: MAKE SURE THE SLING IS RATED UP TO 800 POUNDS (363 KG) TO SUPPORT THE WEIGHT OF THE PROPELLER ASSEMBLY DURING INSTALLATION.

CAUTION 1: INSTRUCTIONS AND PROCEDURES IN THIS SECTION MAY INVOLVE PROPELLER CRITICAL PARTS. REFER TO THE INTRODUCTION CHAPTER OF THIS MANUAL FOR INFORMATION ABOUT PROPELLER CRITICAL PARTS. REFER TO THE ILLUSTRATED PARTS LIST CHAPTER OF THE APPLICABLE OVERHAUL MANUAL(S) FOR THE IDENTIFICATION OF SPECIFIC PROPELLER CRITICAL PARTS.

CAUTION 2: WHEN INSTALLING THE PROPELLER ON THE AIRCRAFT, DO NOT DAMAGE THE ICE PROTECTION SYSTEM COMPONENTS, IF APPLICABLE.

- (1) With a suitable crane hoist and sling, carefully move the propeller assembly to the aircraft engine mounting flange in preparation for installation.

WARNING: CLEANING AGENT MEK IS FLAMMABLE AND TOXIC TO THE SKIN, EYES AND RESPIRATORY TRACT. SKIN AND EYE PROTECTION ARE REQUIRED. AVOID PROLONGED CONTACT. USE IN A WELL VENTILATED AREA.

- (2) Clean the engine flange and propeller flange with Quick Dry Stoddard Solvent or MEK.
- (3) Install the spinner adapter ring on the engine starter ring gear. Refer to Figure 3-5.

CAUTION: FAILURE TO INSTALL THE SHIM BETWEEN THE PROPELLER FLANGE AND THE STARTER RING GEAR CAN RESULT IN BOLT FAILURE.

- (4) Install the shim (Table 3-1) on the engine shaft between the starter ring gear and the propeller flange. Refer to Figure 3-5.
- (5) Lubricate the specified shaft O-ring (Table 3-1) and install it on the engine flange. Refer to Figure 3-5.
- (6) Align the six mounting bolts (already installed in the propeller hub flange) with the threaded bushings in the engine flange.

NOTE: Six propeller mounting bolts will already be installed in the propeller flange. Interference with other propeller parts requires that the bolts be installed during propeller assembly.

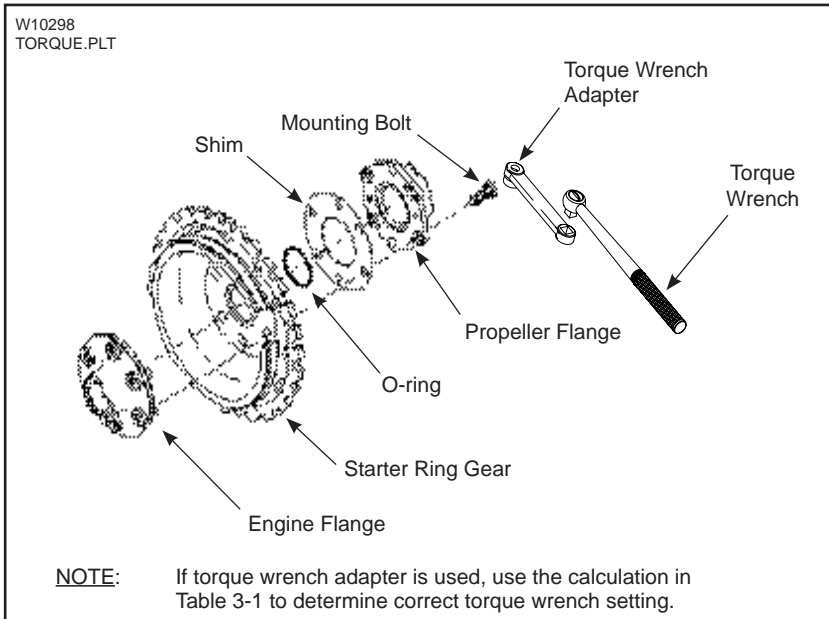

**Installing K or L Flange Propeller on the Engine Flange
Figure 3-6**

CAUTION: MAKE SURE THAT COMPLETE AND TRUE SURFACE CONTACT IS ESTABLISHED BETWEEN THE PROPELLER HUB FLANGE AND THE ENGINE FLANGE.

- (7) Slide the propeller flange onto the engine flange, against the starter ring gear and shim.

NOTE: Insert the engine bushings into the counterbores that encircle the propeller mounting bolts in the propeller flange.

CAUTION: NEW PROPELLER MOUNTING BOLTS MUST BE USED WHEN INITIALLY INSTALLING A NEW OR OVERHAULED PROPELLER.

- (8) Thread the six preinstalled mounting bolts (Table 3-1) through the propeller flange from the propeller side, and into the bushings in the engine flange. Refer to Figure 3-6.

NOTE: The mounting bolts are preinstalled during the assembly of the propeller. Replacement of one of these bolts between overhauls must be performed only by a certified propeller repair station with the appropriate rating.

- (9) Use a torque wrench with the appropriate torque wrench adapter (Figure 3-6) to torque all mounting bolts in sequence. Refer to Table 3-2 and Figure 3-4 to determine the proper torque value to which the torque wrench must be set.

NOTE: Refer to the Tools, Consumables, and Expendables section in this chapter for a list of applicable torque wrench adapters.

- (a) Torque the mounting bolts to half of the final torque, beginning with any mounting bolt, and moving around the clock in either direction.
- (b) Final torque the bolts in sequence, beginning with any mounting bolt, and moving around the clock in either direction.

- (10) Safety all mounting bolts with 0.032 inch (0.81 mm) minimum diameter stainless steel wire or equivalent aircraft safety cable and associated hardware (two bolts per safety).
- (11) If the propeller is equipped with an ice protection system that uses components supplied by Hartzell Propeller Inc., applicable instructions and technical information for the components supplied by Hartzell Propeller Inc. can be found in the following publications available on the Hartzell website at www.hartzellprop.com.
- (a) Manual 180 (30-61-80) - Propeller Ice Protection System Manual
 - (b) Manual 181 (30-60-81) - Propeller Ice Protection Component Maintenance Manual
 - (c) Manual 182 (61-12-82) - Propeller Electrical De-ice Boot Removal and Installation Manual
 - (d) Manual 183 (61-12-83) - Propeller Anti-icing Boot Removal and Installation Manual
- (12) Propeller ice protection system components not supplied by Hartzell Propeller Inc. are controlled by the applicable TC or STC holder's Instructions for Continued Airworthiness (ICA).

(13) Install the spinner dome as follows:

NOTE: The following instructions relate to Hartzell spinners only. In some cases, the airframe manufacturer produced the spinner assembly. In those cases, refer to the airframe manufacturer's manual for spinner installation instructions.

CAUTION 1: TO PREVENT DAMAGE TO THE BLADE AND BLADE PAINT, WRAP THE BLADE SHANKS IN SEVERAL LAYERS OF MASKING OR DUCT TAPE BEFORE INSTALLING THE SPINNER DOME. REMOVE THE TAPE AFTER THE SPINNER IS INSTALLED.

CAUTION 2: THE SPINNER DOME WILL WOBBLE IF NOT ALIGNED PROPERLY, AND MAY AFFECT THE BALANCE OF THE PROPELLER.

- (a) Carefully slide the spinner dome over the reinstalled propeller.
- (b) Secure the spinner dome to the spinner bulkhead with the supplied screws and washers.

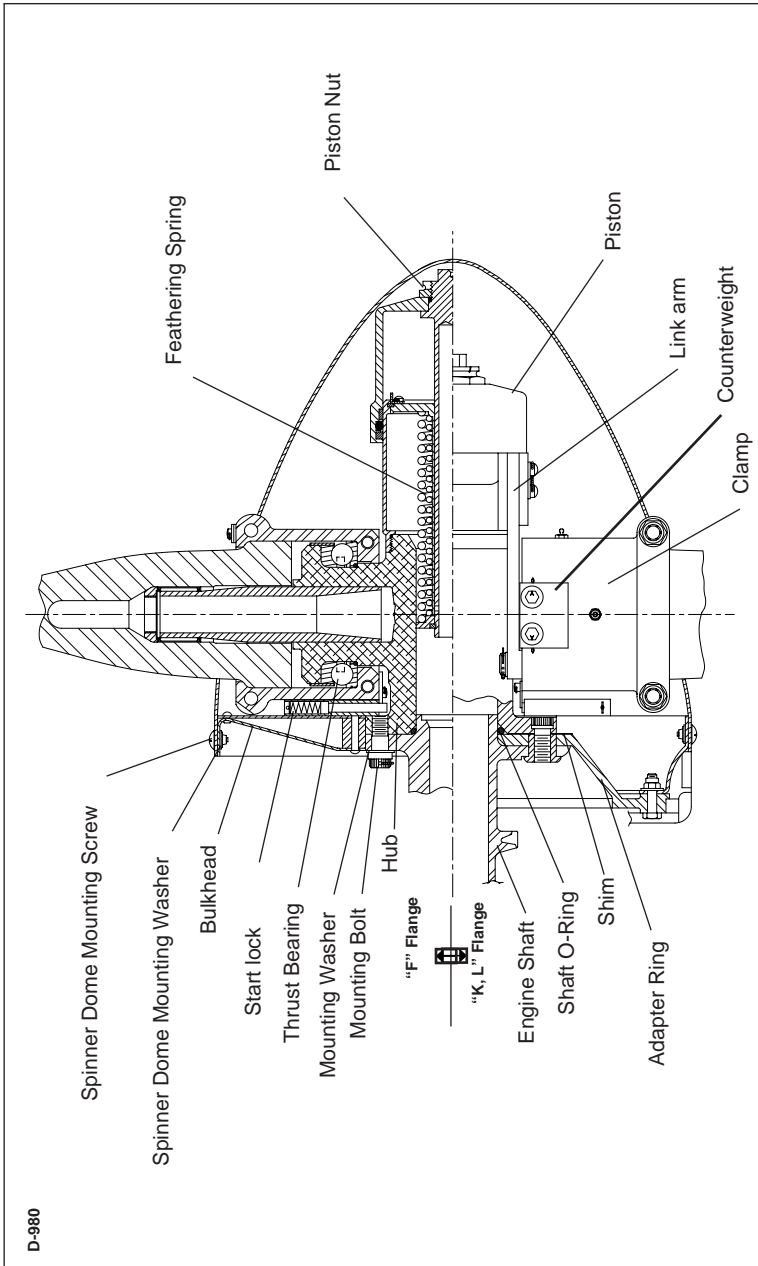

**HC-A2(MV,V)(F,K,L)-2() Propeller Assembly
Figure 3-7**

D-980

- E. Installing F Flange Propeller Models HC-A2(MV,V)F-2()
Refer to Figure 3-7.

CAUTION: INSERT THE DOWEL PINS INTO THE PROPELLER FLANGE USING A BRASS HAMMER OR EQUIVALENT TOOL TO PREVENT DAMAGE TO THE DOWEL PINS. THE DOWEL PINS ARE AN INTERFERENCE FIT WITH THE PROPELLER FLANGE.

- (1) Insert two dowel pins (Table 3-1) through the threadless holes in the propeller flange, flush with the propeller side of the hub flange. The dowel pins will protrude from the engine side of the hub flange to engage the engine flange.

WARNING: MAKE SURE THE SLING IS RATED UP TO 800 POUNDS (363 KG) TO SUPPORT THE WEIGHT OF THE PROPELLER ASSEMBLY DURING REMOVAL.

CAUTION 1: INSTRUCTIONS AND PROCEDURES IN THIS SECTION MAY INVOLVE PROPELLER CRITICAL PARTS. REFER TO THE INTRODUCTION CHAPTER OF THIS MANUAL FOR INFORMATION ABOUT PROPELLER CRITICAL PARTS. REFER TO THE ILLUSTRATED PARTS LIST CHAPTER OF THE APPLICABLE OVERHAUL MANUAL(S) FOR THE IDENTIFICATION OF SPECIFIC PROPELLER CRITICAL PARTS.

CAUTION 2: WHEN INSTALLING THE PROPELLER ON THE AIRCRAFT, DO NOT DAMAGE THE ICE PROTECTION SYSTEM COMPONENTS, IF APPLICABLE.

- (2) With a suitable crane hoist and sling, carefully move the propeller assembly to the aircraft engine mounting flange in preparation for installation.

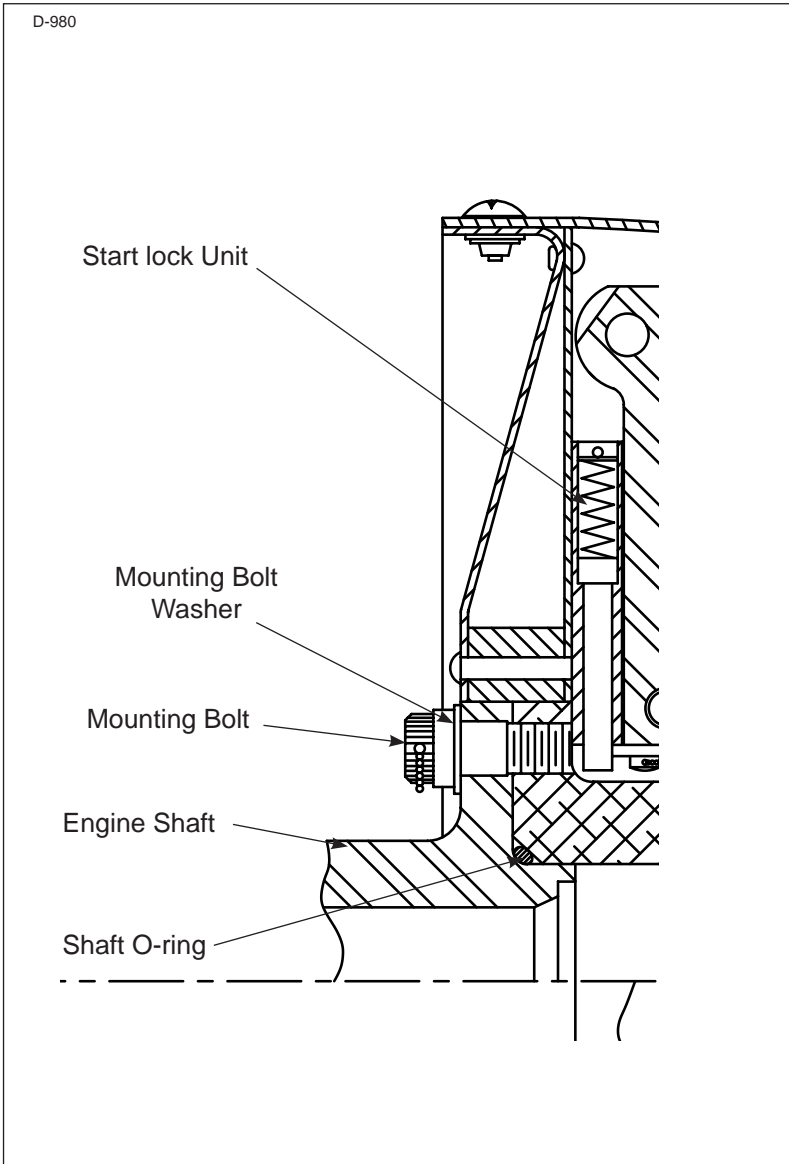

**F Flange Installation on -2 Propeller Models
Figure 3-8**

WARNING: CLEANING AGENT MEK IS FLAMMABLE AND TOXIC TO THE SKIN, EYES AND RESPIRATORY TRACT. SKIN AND EYE PROTECTION ARE REQUIRED. AVOID PROLONGED CONTACT. USE IN A WELL VENTILATED AREA.

- (3) Clean the engine flange and propeller flange with Quick Dry Stoddard Solvent or MEK.

WARNING: USE CAUTION DURING INSTALLATION IF THE START LOCKS HAVE BEEN ENGAGED TO FACILITATE INSTALLATION OF THE SPINNER BULKHEAD. IF THE BLADES ARE RELEASED SUDDENLY, THE EXTREME FORCE CAN CAUSE SERIOUS INJURY AND DAMAGE TO THE PROPELLER.

- (4) If the spinner bulkhead is to be installed and is not already in place, perform the following steps:

NOTE: The start locks must be engaged to provide access to the spinner bulkhead mounting bolts when installing the spinner bulkhead.

- (a) Position the spinner bulkhead on the propeller.
 - (b) From the engine side of the bulkhead, insert the attaching bolts through the bulkhead and into the start locks.
 - (c) Install the washers and locking nuts (Table 3-1) on the propeller side of the start locks to secure the attaching bolts and the bulkhead.
- (5) Lubricate the specified shaft O-ring (Table 3-1) and install it on the engine flange (Figure 3-8).

CAUTION: USE CARE TO AVOID SCRAPING ALUMINUM FROM THE BORE OF THE SPINNER BULKHEAD. SCRAPINGS COULD BECOME WEDGED BETWEEN THE FLANGES.

- (6) Align the threaded holes of the propeller flange with the bolt holes in the engine flange, and align the dowel pins in the propeller flange with the dowel pin holes in the engine flange.

CAUTION: MAKE SURE THAT COMPLETE AND TRUE SURFACE CONTACT IS ESTABLISHED BETWEEN THE PROPELLER HUB FLANGE AND THE ENGINE FLANGE.

(7) Slide the propeller onto the engine shaft.

CAUTION: NEW PROPELLER MOUNTING BOLTS MUST BE USED WHEN INITIALLY INSTALLING A NEW OR OVERHAULED PROPELLER.

(8) Install mounting bolts (Table 3-1) with mounting washers through the engine flange from the engine side and into the tapped holes in the propeller flange.

NOTE: For propeller removals between overhaul intervals, mounting bolts and washers may be reused if they are not damaged or corroded.

(9) Use a torque wrench with the appropriate torque wrench adapter (Figure 3-6) to torque all mounting bolts in sequence. Refer to Table 3-2 and Figure 3-4 to determine the proper torque value to which the torque wrench must be set.

NOTE: Refer to the Tools, Consumables, and Expendables section in this chapter for a list of applicable torque wrench adapters.

(a) Torque the mounting bolts to half of the final torque, beginning with any mounting bolt, and moving around the clock in either direction.

(b) Final torque the bolts in sequence, beginning with any mounting bolt, and moving around the clock in either direction.

(10) Safety all mounting bolts with 0.032 inch (0.810 mm) minimum diameter stainless steel wire or equivalent aircraft safety cable and associated hardware (two bolts per safety).

(11) Procedure for reinstallation of the piston nut, if applicable.

(a) Following the installation of the propeller, retract the start lock pins and hold them in place with a heavy wire inserted through the hole of each start lock housing.

(b) Carefully push the piston toward the engine, rotate the blades to feather position, and attach the piston nut to the pitch change rod.

- (c) Use a breaker bar and a 5/8 inch deep well socket to hold the pitch change rod.
- (d) Using a 1-13/16 inch crowfoot wrench and a torque wrench, torque the piston nut. Refer to Table 3-2 and Figure 3-4 for the proper torque value.

NOTE: The removal and subsequent reinstallation of the piston nut does not require that the propeller blade angles be rechecked.

(12) Remove the wires from the start lock brackets.

CAUTION: DO NOT PUT THE BLADE PADDLE IN THE AREA OF THE DE-ICE BOOT WHEN APPLYING TORQUE TO A BLADE ASSEMBLY. PUT THE BLADE PADDLE IN THE THICKEST AREA OF THE BLADE, JUST OUTSIDE OF THE DE-ICE BOOT. USE ONE BLADE PADDLE PER BLADE.

(13) Position the propeller on the start locks.

- (a) Using the blade paddles, slowly rotate the blades simultaneously toward low pitch until the start lock pins engage the start lock plates.

(14) If the propeller is equipped with an ice protection system that uses components supplied by Hartzell Propeller Inc., applicable instructions and technical information for the components supplied by Hartzell can be found in the following publications available on the Hartzell website at www.hartzellprop.com.

- (a) Manual 180 (30-61-80) - Propeller Ice Protection System Manual
- (b) Manual 181 (30-60-81) - Propeller Ice Protection Component Maintenance Manual
- (c) Manual 182 (61-12-82) - Propeller Electrical De-ice Boot Removal and Installation Manual
- (d) Manual 183 (61-12-83) - Propeller Anti-icing Boot Removal and Installation Manual

(15) Propeller ice protection system components not supplied by Hartzell Propeller Inc. are controlled by the applicable TC or STC holder's Instructions for Continued Airworthiness (ICA).

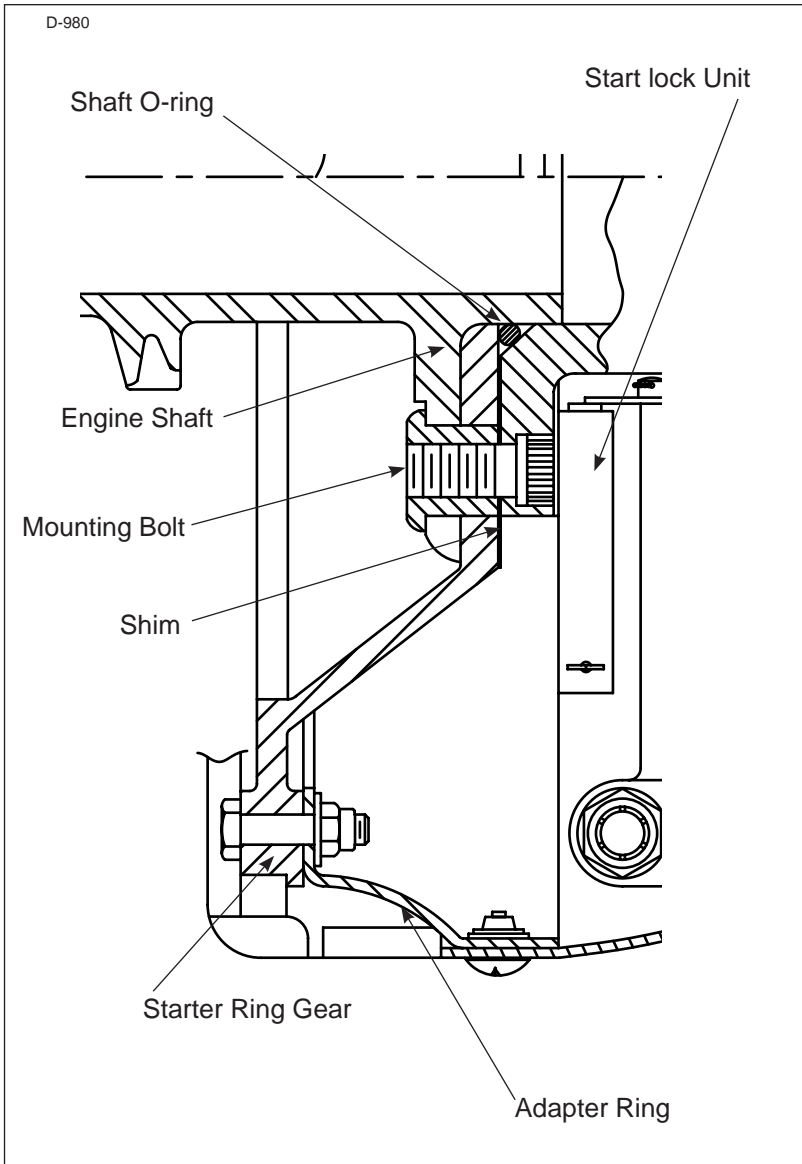

K and L Flange Installation on -2 Propeller Models
Figure 3-9

(16) Install the spinner dome as follows:

NOTE: The following instructions relate to Hartzell spinners only. In some cases, the airframe manufacturer produced the spinner assembly. In those cases, refer to the airframe manufacturer's manual for spinner installation instructions.

CAUTION 1: TO PREVENT DAMAGE TO THE BLADE AND BLADE PAINT, WRAP THE BLADE SHANKS IN SEVERAL LAYERS OF MASKING OR DUCT TAPE BEFORE INSTALLING THE SPINNER DOME. REMOVE THE TAPE AFTER THE SPINNER IS INSTALLED.

CAUTION 2: THE SPINNER DOME WILL WOBBLE IF NOT ALIGNED PROPERLY, AND MAY AFFECT THE BALANCE OF THE PROPELLER.

- (a) Carefully slide the spinner dome over the reinstalled propeller.
- (b) Secure the spinner dome to the spinner bulkhead with the supplied screws and washers.

F. Installing K and L Flange Propeller Models
HC-A2(MV,V)(K,L)-2

Refer to Figure 3-7.

WARNING 1: TO FACILITATE BOXING AND SHIPPING OF THE PROPELLER, THE PISTON NUT MAY HAVE BEEN REMOVED TO ALLOW ROTATING OF THE BLADES BEFORE PACKAGING.

FOR SAFETY REASONS, IF THE PISTON NUT WAS NOT REMOVED, THE PROPELLER MUST BE PLACED IN FEATHER POSITION BEFORE IT IS INSTALLED ON THE AIRCRAFT.

WARNING 2: MAKE SURE THE SLING IS RATED UP TO 800 POUNDS (363 KG) TO SUPPORT THE WEIGHT OF THE PROPELLER ASSEMBLY DURING REMOVAL.

CAUTION 1: INSTRUCTIONS AND PROCEDURES IN THIS SECTION MAY INVOLVE PROPELLER CRITICAL PARTS. REFER TO THE INTRODUCTION CHAPTER OF THIS MANUAL FOR INFORMATION ABOUT PROPELLER CRITICAL PARTS. REFER TO THE ILLUSTRATED PARTS LIST CHAPTER OF THE APPLICABLE OVERHAUL MANUAL(S) FOR THE IDENTIFICATION OF SPECIFIC PROPELLER CRITICAL PARTS.

CAUTION 2: WHEN INSTALLING THE PROPELLER ON THE AIRCRAFT, DO NOT DAMAGE THE ICE PROTECTION SYSTEM COMPONENTS, IF APPLICABLE.

- (1) With a suitable crane hoist and sling, carefully move the propeller assembly to the aircraft engine mounting flange in preparation for installation.

WARNING: CLEANING AGENT MEK IS FLAMMABLE AND TOXIC TO THE SKIN, EYES AND RESPIRATORY TRACT. SKIN AND EYE PROTECTION ARE REQUIRED. AVOID PROLONGED CONTACT. USE IN A WELL VENTILATED AREA.

- (2) Clean the engine flange and propeller flange with Quick Dry Stoddard Solvent or MEK.
- (3) Install the spinner adapter ring on the engine starter ring gear. Refer to Figure 3-9.

CAUTION: FAILURE TO INSTALL THE SHIM BETWEEN THE PROPELLER FLANGE AND THE STARTER RING GEAR CAN RESULT IN MOUNTING BOLT FAILURE.

- (4) Install the shim (Table 3-1) on the engine shaft between the starter ring gear and the propeller flange. Refer to Figure 3-9.

- (5) Install the specified O-ring (Table 3-1) on the engine flange. Refer to Figure 3-9.

CAUTION: USING A FELT-TIPPED PEN, IDENTIFY EACH START LOCK AND ITS ADJACENT BLADE CLAMP WITH A CORRESPONDING LETTER. THIS WILL INSURE THAT EACH START LOCK WILL BE REINSTALLED WITH THE CORRECT BLADE CLAMP TO MAINTAIN THE SAME BLADE ANGLES FOR ENGINE START.

- (6) Remove each start lock to allow access to preinstalled propeller mounting bolts.
- (7) Align the two mounting bolts (already installed in the propeller hub flange) with the threaded bushings in the engine flange.

NOTE: Two propeller mounting bolts will already be installed in the propeller flange. Interference with blade clamps requires that the bolts be installed during propeller assembly.

CAUTION: MAKE SURE THAT COMPLETE AND TRUE SURFACE CONTACT IS ESTABLISHED BETWEEN THE PROPELLER HUB FLANGE AND THE ENGINE FLANGE.

- (8) Slide the propeller flange onto the engine flange, against the starter ring gear and shim.

NOTE: Insert the engine bushings into the counterbores that encircle the propeller mounting bolts in the propeller flange.

CAUTION: NEW PROPELLER MOUNTING BOLTS MUST BE USED WHEN INITIALLY INSTALLING A NEW OR OVERHAULED PROPELLER.

- (9) Thread the two preinstalled mounting bolts (Table 3-1) through the propeller flange from the propeller side, and into the bushings in the engine flange. Refer to Figure 3-9.

NOTE: Two of the mounting bolts are preinstalled during the assembly of the propeller. Replacement of one of these bolts between overhauls must be performed only by a certified propeller repair station with the appropriate rating.

- (10) Install four mounting bolts (Table 3-1) in the remaining four mounting holes and thread them through the propeller flange from the propeller side into the bushings in the engine flange. Refer to Figure 3-9.

NOTE: For propeller removals between overhaul intervals, mounting bolts and washers may be reused if they are not damaged or corroded.

- (11) Use a torque wrench with the appropriate torque wrench adapter to torque all mounting bolts in sequence. Refer to Table 3-2 and Figure 3-4 to determine the proper torque value to which the torque wrench must be set.

NOTE: Refer to the Tools, Consumables, and Expendables section in this chapter for a list of applicable torque wrench adapters.

- (a) Torque the mounting bolts to half of the final torque, beginning with any mounting bolt, and moving around the clock in either direction.
- (b) Final torque the bolts in sequence, beginning with any mounting bolt, and moving around the clock in either direction.

- (12) Reinstall each start lock adjacent to the blade clamp that has a corresponding felt-tip marked letter.

- (13) Safety all mounting bolts with 0.032 inch (0.810 mm) minimum diameter stainless steel wire or equivalent aircraft safety cable and associated hardware (two bolts per safety).

NOTE: The mounting bolts that are adjacent to the start lock units must be safety-wired to the hex head bolts that attach the start lock brackets to the hub.

- (14) Procedure for reinstallation of the piston nut, if applicable.

- (a) Following the installation of the propeller, retract the start lock pins and hold them in place with a heavy wire inserted through the hole of each start lock housing.
- (b) Carefully push the piston toward the engine, rotate the blades to feather position, and attach the piston nut to the pitch change rod.

- (c) Use a breaker bar and a 5/8 inch deep well socket to hold the pitch change rod.
- (d) Using a 1-13/16 inch crowfoot wrench and a torque wrench, torque the piston nut. Refer to Table 3-2 and Figure 3-4 for the proper torque value.

NOTE: The removal and subsequent reinstallation of the piston nut do not require that the propeller blade angles be rechecked.

- (15) Remove the wires from the start lock brackets.

CAUTION: DO NOT PUT THE BLADE PADDLE IN THE AREA OF THE DE-ICE BOOT WHEN APPLYING TORQUE TO A BLADE ASSEMBLY. PUT THE BLADE PADDLE IN THE THICKEST AREA OF THE BLADE, JUST OUTSIDE OF THE DE-ICE BOOT. USE ONE BLADE PADDLE PER BLADE.

- (16) Position the propeller on the start locks.

- (a) Using the blade paddles, slowly rotate the blades simultaneously toward low pitch until the start lock pins engage the start lock plate.

- (17) If the propeller is equipped with an ice protection system that uses components supplied by Hartzell Propeller Inc., applicable instructions and technical information for the components supplied by Hartzell Propeller Inc. can be found in the following publications available on the Hartzell Propeller Inc. website at www.hartzellprop.com.

- (a) Manual 180 (30-61-80) - Propeller Ice Protection System Manual
- (b) Manual 181 (30-60-81) - Propeller Ice Protection Component Maintenance Manual
- (c) Manual 182 (61-12-82) - Propeller Electrical De-ice Boot Removal and Installation Manual
- (d) Manual 183 (61-12-83) - Propeller Anti-icing Boot Removal and Installation Manual

- (18) Propeller ice protection system components not supplied by Hartzell Propeller Inc. are controlled by the applicable TC or STC holder's Instructions for Continued Airworthiness (ICA).

D-1495

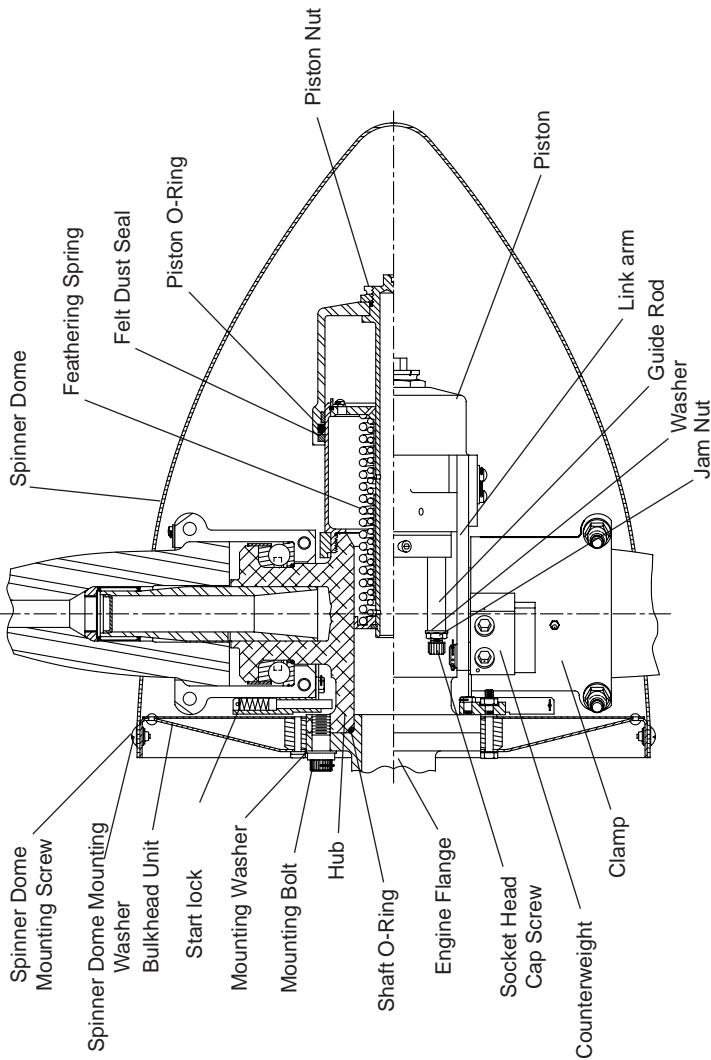

(E,P)HC-A3(MV,V)F-2(X) Propeller Assembly
Figure 3-10

(19) Install the spinner dome as follows:

NOTE: The following instructions relate to Hartzell Propeller Inc. spinners only. In some cases, the airframe manufacturer produced the spinner assembly. In those cases, refer to the airframe manufacturer's manual for spinner installation instructions.

CAUTION 1: TO PREVENT DAMAGE TO THE BLADE AND BLADE PAINT, WRAP THE BLADE SHANKS IN SEVERAL LAYERS OF MASKING OR DUCT TAPE BEFORE INSTALLING THE SPINNER DOME. REMOVE THE TAPE AFTER THE SPINNER IS INSTALLED.

CAUTION 2: THE SPINNER DOME WILL WOBBLE IF NOT ALIGNED PROPERLY, AND MAY AFFECT THE BALANCE OF THE PROPELLER.

- (a) Carefully slide the spinner dome over the reinstalled propeller.
- (b) Secure the spinner dome to the spinner bulkhead with the supplied screws and washers.

- G. Installing F Flange Propeller Models
(E,P)HC-A3(MV,V)F-2() except those using a spacer as specified in paragraph 4.H
Refer to Figure 3-10.

CAUTION 1: INSTRUCTIONS AND PROCEDURES IN THIS SECTION MAY INVOLVE PROPELLER CRITICAL PARTS. REFER TO THE INTRODUCTION CHAPTER OF THIS MANUAL FOR INFORMATION ABOUT PROPELLER CRITICAL PARTS. REFER TO THE ILLUSTRATED PARTS LIST CHAPTER OF THE APPLICABLE OVERHAUL MANUAL(S) FOR THE IDENTIFICATION OF SPECIFIC PROPELLER CRITICAL PARTS.

CAUTION 2: INSERT THE DOWEL PINS INTO THE PROPELLER FLANGE USING A BRASS HAMMER OR EQUIVALENT TOOL TO PREVENT DAMAGE TO THE DOWEL PINS. THE DOWEL PINS ARE AN INTERFERENCE FIT WITH THE PROPELLER FLANGE.

- (1) Insert two dowel pins (Table 3-1) through the threadless holes in the propeller flange, flush with the propeller side of the hub flange. The dowel pins will protrude from the engine side of the hub flange to engage the engine flange.

WARNING 1: TO FACILITATE BOXING AND SHIPPING OF THE PROPELLER, THE PISTON NUT MAY HAVE BEEN REMOVED TO ALLOW ROTATION OF THE BLADES BEFORE PACKAGING.

WARNING 2: MAKE SURE THE SLING IS RATED UP TO 800 POUNDS (363 KG) TO SUPPORT THE WEIGHT OF THE PROPELLER ASSEMBLY DURING INSTALLATION.

CAUTION: WHEN INSTALLING THE PROPELLER ON THE AIRCRAFT, DO NOT DAMAGE THE ICE PROTECTION SYSTEM COMPONENTS, IF APPLICABLE.

- (2) With a suitable crane hoist and sling, carefully move the propeller assembly to the aircraft engine mounting flange in preparation for installation.

WARNING: CLEANING AGENT MEK IS FLAMMABLE AND TOXIC TO THE SKIN, EYES AND RESPIRATORY TRACT. SKIN AND EYE PROTECTION ARE REQUIRED. AVOID PROLONGED CONTACT. USE IN A WELL VENTILATED AREA.

- (3) Clean the engine flange and propeller flange with Quick Dry Stoddard Solvent or MEK.

WARNING: USE CAUTION DURING INSTALLATION IF THE START LOCKS HAVE BEEN ENGAGED TO FACILITATE INSTALLATION OF THE SPINNER BULKHEAD. IF THE BLADES ARE RELEASED SUDDENLY, THE EXTREME FORCE CAN CAUSE SERIOUS INJURY AND DAMAGE TO THE PROPELLER.

- (4) If the spinner bulkhead is to be installed and is not already in place, perform the following steps:

NOTE: The start locks must be engaged to provide access to the spinner mounting bolts when installing the spinner bulkhead.

- (a) Install the spinner bulkhead facing toward the engine.
 - (b) From the engine side of the bulkhead, insert the attaching bolts through the bulkhead and into the start lock units.
 - (c) Install the washers and locking nuts (Table 3-1) on the propeller side of the start lock to secure the attaching bolts and the bulkhead.
- (5) Lubricate the specified shaft O-ring (Table 3-1) and install it on the engine flange.

CAUTION: USE CARE TO AVOID SCRAPING ALUMINUM FROM THE BORE OF THE SPINNER BULKHEAD. SCRAPINGS COULD BECOME WEDGED BETWEEN THE FLANGES.

- (6) Align the threaded holes of the propeller flange with the bolt holes in the engine flange, and align the dowel pins in the propeller flange with the dowel pin holes in the engine flange.

CAUTION: MAKE SURE THAT COMPLETE AND TRUE SURFACE CONTACT IS ESTABLISHED BETWEEN THE PROPELLER HUB FLANGE AND THE ENGINE FLANGE.

- (7) Slide the propeller onto the engine shaft.

CAUTION: NEW PROPELLER MOUNTING BOLTS MUST BE USED WHEN INITIALLY INSTALLING A NEW OR OVERHAULED PROPELLER.

- (8) Install mounting bolts (Table 3-1) with mounting washers through the engine flange from the engine side and into the tapped holes in the propeller flange.

NOTE: For propeller removals between overhaul intervals, mounting bolts and washers may be reused if they are not damaged or corroded.

(This page is intentionally blank.)

- (9) Use a torque wrench with the appropriate torque wrench adapter (Figure 3-3) to torque all mounting bolts in sequence. Refer to Table 3-2 and Figure 3-4 to determine the proper torque value to which the torque wrench must be set.

NOTE: Refer to the Tools, Consumables, and Expendables section in this chapter for a list of applicable torque wrench adapters.

- (a) Torque the mounting bolts to half of the final torque, beginning with any mounting bolt, and moving around the clock in either direction.
- (b) Final torque the bolts in sequence, beginning with any mounting bolt, and moving around the clock in either direction.
- (10) Safety all mounting bolts with 0.032 inch (0.81 mm) minimum diameter stainless steel wire or equivalent aircraft safety cable and associated hardware (two bolts per safety).
- (11) Procedure for reinstallation of the piston nut, if applicable.
- (a) Following the installation of the propeller, retract the start lock pins and hold them in place with a heavy wire inserted through the hole of each start lock housing
- (b) Carefully push the piston toward the engine, rotating the blades to feather position, and attach the piston nut to the pitch change rod.
- (c) Use a breaker bar and a 5/8 inch deep well socket to hold the pitch change rod.
- (d) Using a 1-13/16 inch crowfoot wrench and a torque wrench, torque the piston nut. Refer to Table 3-2 and Figure 3-4 for the proper torque value.

NOTE: The removal and subsequent reinstallation of the piston nut does not require that the propeller blade angles be rechecked.

- (12) Remove the wires from the start lock brackets.

CAUTION: DO NOT PUT THE BLADE PADDLE IN THE AREA OF THE DE-ICE BOOT WHEN APPLYING TORQUE TO A BLADE ASSEMBLY. PUT THE BLADE PADDLE IN THE THICKEST AREA OF THE BLADE, JUST OUTSIDE OF THE DE-ICE BOOT. USE ONE BLADE PADDLE PER BLADE.

(13) Position the propeller on the start locks.

- (a) Using the blade paddles, slowly rotate the blades simultaneously toward low pitch until the start lock pins engage the start lock plates.

(14) If the propeller is equipped with an ice protection system that uses components supplied by Hartzell Propeller Inc., applicable instructions and technical information for the components supplied by Hartzell can be found in the following publications available on the Hartzell website at www.hartzellprop.com.

- (a) Manual 180 (30-61-80) - Propeller Ice Protection System Manual
- (b) Manual 181 (30-60-81) - Propeller Ice Protection Component Maintenance Manual
- (c) Manual 182 (61-12-82) - Propeller Electrical De-ice Boot Removal and Installation Manual
- (d) Manual 183 (61-12-83) - Propeller Anti-icing Boot Removal and Installation Manual

(15) Propeller ice protection system components not supplied by Hartzell Propeller Inc. are controlled by the applicable TC or STC holder's Instructions for Continued Airworthiness (ICA).

(16) Install the spinner dome as follows:

NOTE: The following instructions relate to Hartzell spinners only. In some cases, the airframe manufacturer produced the spinner assembly. In those cases, refer to the airframe manufacturer's manual for spinner installation instructions.

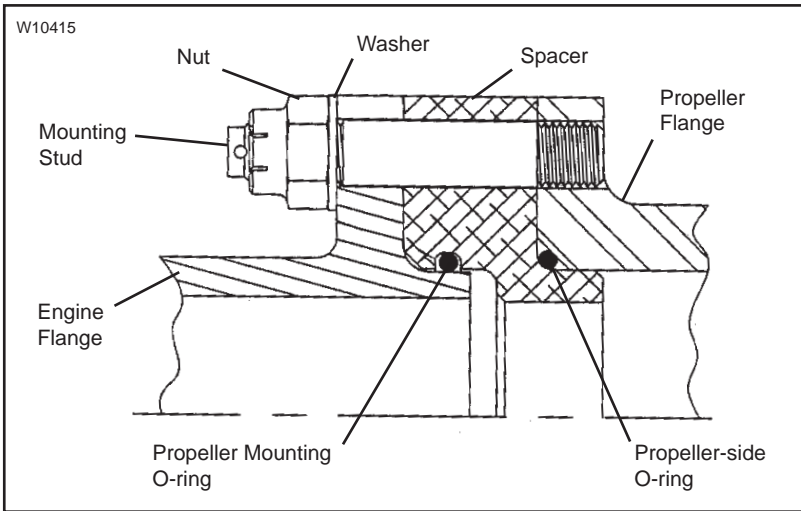

EHC-A3(MV,V)F-2B Mounting Parts
Figure 3-11

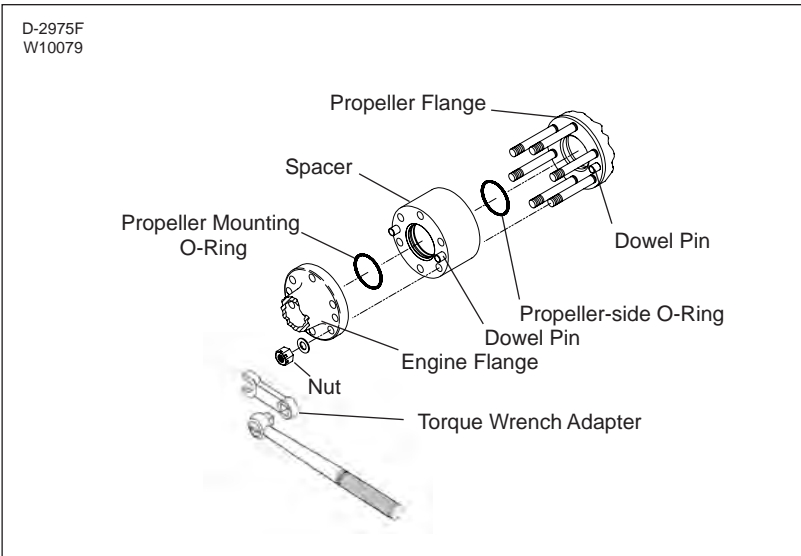

EHC-A3(MV,V)F-2B Installation
Figure 3-12

CAUTION 1: TO PREVENT DAMAGE TO THE BLADE AND BLADE PAINT, WRAP THE BLADE SHANKS IN SEVERAL LAYERS OF MASKING OR DUCT TAPE BEFORE INSTALLING THE SPINNER DOME. REMOVE THE TAPE AFTER THE SPINNER IS INSTALLED.

CAUTION 2: THE SPINNER DOME WILL WOBBLE IF NOT ALIGNED PROPERLY, AND MAY AFFECT THE BALANCE OF THE PROPELLER.

- (a) Carefully slide the spinner dome over the reinstalled propeller.
- (b) Secure the spinner dome to the spinner bulkhead with the supplied screws and washers.

H. Installing the EHC-A3(MV,V)F-2B Propeller using a spacer as installed on, but not limited to, the Beech 95-55, -A55, -B55, Colemill Baron Aircraft Engines, and Aero Commander Aircraft

Refer to Figure 3-11 and Figure 3-12.

- (1) If the spacer, four dowel pins, and spacer-to-propeller flange O-ring are already installed on the propeller, go to step 3.H.(6).

WARNING: TO FACILITATE BOXING AND SHIPPING OF THE PROPELLER, THE PISTON NUT MAY HAVE BEEN REMOVED IN ORDER TO ALLOW ROTATING OF THE BLADES BEFORE PACKAGING.

CAUTION 1: INSTRUCTIONS AND PROCEDURES IN THIS SECTION MAY INVOLVE PROPELLER CRITICAL PARTS. REFER TO THE INTRODUCTION CHAPTER OF THIS MANUAL FOR INFORMATION ABOUT PROPELLER CRITICAL PARTS. REFER TO THE ILLUSTRATED PARTS LIST CHAPTER OF THE APPLICABLE OVERHAUL MANUAL(S) FOR THE IDENTIFICATION OF SPECIFIC PROPELLER CRITICAL PARTS.

CAUTION: INSERT THE DOWEL PINS INTO THE PROPELLER FLANGE USING A BRASS HAMMER OR EQUIVALENT TOOL TO PREVENT DAMAGE TO THE DOWEL PINS. THE DOWEL PINS ARE AN INTERFERENCE FIT WITH THE PROPELLER FLANGE.

- (2) Insert two dowel pins (Table 3-1) through the threadless holes in the propeller flange, flush with the propeller side of the hub flange. The dowel pins will protrude from the engine side of the hub flange to engage the engine flange.
- (3) Install the propeller side O-ring (Table 3-1) on the spacer, facing the propeller flange. Refer to Figure 3-11 and Figure 3-12.
- (4) Install the spacer and O-ring (Table 3-1) against the propeller flange, matching the dowel pins in the propeller flange to the holes in the spacer. Refer to Figure 3-12.
- (5) Press two dowel pins (Table 3-1) in the two 0.50 inch (12.7 mm) diameter holes in the spacer, approximately 0.50 inch (12.7 mm) deep. Refer to Figure 3-12.

WARNING: MAKE SURE THE SLING IS RATED UP TO 800 POUNDS (363 KG) TO SUPPORT THE WEIGHT OF THE PROPELLER ASSEMBLY DURING INSTALLATION.

CAUTION: WHEN INSTALLING THE PROPELLER ON THE AIRCRAFT, DO NOT DAMAGE THE ICE PROTECTION SYSTEM COMPONENTS, IF APPLICABLE.

- (6) With a suitable crane hoist and sling, carefully move the propeller assembly to the aircraft engine mounting flange.

WARNING: CLEANING AGENT MEK IS FLAMMABLE AND TOXIC TO THE SKIN, EYES AND RESPIRATORY TRACT. SKIN AND EYE PROTECTION ARE REQUIRED. AVOID PROLONGED CONTACT. USE IN A WELL VENTILATED AREA.

- (7) Clean the engine flange and propeller flange with Quick Dry Stoddard Solvent or MEK.

CAUTION: DO NOT INSTALL THE PROPELLER MOUNTING O-RING DIRECTLY ON THE ENGINE FLANGE. STEEL HUB PROPELLERS WITH ALUMINUM SPACERS REQUIRE ONLY INSTALLATION OF A SINGLE PROPELLER MOUNTING O-RING INTO THE O-RING GROOVE INSIDE THE ALUMINUM SPACER.

(8) Install the propeller mounting O-ring (Table 3-1) into the recessed O-ring groove in the aluminum spacer. Refer to Figure 3-11 and Figure 3-12.

(9) Align the mounting and dowel pin holes in the engine flange with the mounting studs and dowel pins in the spacer.

(10) Slide the spacer and propeller on the engine flange.

CAUTION 1: MAKE SURE THAT COMPLETE AND TRUE SURFACE CONTACT IS ESTABLISHED BETWEEN THE PROPELLER HUB FLANGE SPACER AND THE ENGINE FLANGE.

CAUTION 2: NEW PROPELLER NUTS AND WASHERS MUST BE USED WHEN INITIALLY INSTALLING A NEW OR OVERHAULED PROPELLER.

(11) Install mounting washers and nuts (Table 3-1) onto the mounting studs that protrude through the engine side of the engine flange (Figure 3-12).

NOTE: For propeller removals between overhaul intervals, studs, nuts, and washers may be reused if they are not damaged or corroded.

(12) Use a torque wrench with the appropriate torque wrench adapter (Figure 3-12) to torque all mounting nuts in sequence. Refer to Table 3-2 and Figure 3-4 to determine the proper torque value to which the torque wrench must be set.

NOTE: Refer to the Tools, Consumables, and Expendables section in this chapter for a list of applicable torque wrench adapters.

- (a) Torque the mounting nuts to half of the final torque, beginning with any mounting nut, and moving around the clock in either direction.
- (b) Final torque the mounting nuts in sequence, beginning with any mounting nut, and moving around the clock in either direction.

(13) Procedure for reinstallation of the piston nut, if applicable.

- (a) Following the installation of the propeller, retract the start lock pins and hold them in place with a heavy wire inserted through the hole of each start lock housing
- (b) Carefully push the piston toward the engine, rotating the blades to feather position, and attach the piston nut to the pitch change rod.
- (c) Use a breaker bar and a 5/8 inch deep well socket to hold the pitch change rod.
- (d) Using a 1-13/16 inch crowfoot wrench and a torque wrench, torque the piston nut. Refer to Table 3-2 and Figure 3-4 for the proper torque value.

NOTE: The removal and subsequent reinstallation of the piston nut does not require that the propeller blade angles be rechecked.

(14) Remove the wires from the start lock brackets, if applicable.

CAUTION: DO NOT PUT THE BLADE PADDLE IN THE AREA OF THE DE-ICE BOOT WHEN APPLYING TORQUE TO A BLADE ASSEMBLY. PUT THE BLADE PADDLE IN THE THICKEST AREA OF THE BLADE, JUST OUTSIDE OF THE DE-ICE BOOT. USE ONE BLADE PADDLE PER BLADE.

- (15) Position the propeller on the start locks.
- (a) Using the blade paddles, slowly rotate the blades simultaneously toward low pitch until the start lock pins engage the start lock plates.
- (16) Safety all mounting studs with 0.032 inch (0.81 mm) minimum diameter stainless steel wire or equivalent aircraft safety cable and associated hardware (two studs per safety).
- (17) If the propeller is equipped with an ice protection system that uses components supplied by Hartzell Propeller Inc., applicable instructions and technical information for the components supplied by Hartzell Propeller Inc. can be found in the following publications available on the Hartzell Propeller Inc. website at www.hartzellprop.com.
- (a) Hartzell Propeller Inc. Manual 180 (30-61-80) - Propeller Ice Protection System Manual
 - (b) Hartzell Propeller Inc. Manual 181 (30-60-81) - Propeller Ice Protection Component Maintenance Manual
 - (c) Hartzell Propeller Inc. Manual 182 (61-12-82) - Propeller Electrical De-ice Boot Removal and Installation Manual
 - (d) Hartzell Propeller Inc. Manual 183 (61-12-83) - Propeller Anti-icing Boot Removal and Installation Manual
- (18) Propeller ice protection system components not supplied by Hartzell Propeller Inc. are controlled by the applicable TC or STC holder's Instructions for Continued Airworthiness (ICA).

(19) Install the spinner dome as follows:

NOTE: The following instructions relate to Hartzell spinners only. In some cases, the airframe manufacturer produced the spinner assembly. In those cases, refer to the airframe manufacturer's manual for spinner installation instructions.

CAUTION 1: TO PREVENT DAMAGE TO THE BLADE AND BLADE PAINT, WRAP THE BLADE SHANKS IN SEVERAL LAYERS OF MASKING OR DUCT TAPE BEFORE INSTALLING THE SPINNER DOME. REMOVE THE TAPE AFTER THE SPINNER IS INSTALLED.

CAUTION 2: THE SPINNER DOME WILL WOBBLE IF NOT ALIGNED PROPERLY, AND MAY AFFECT THE BALANCE OF THE PROPELLER.

- (a) Carefully slide the spinner dome over the reinstalled propeller.
- (b) Secure the spinner dome to the spinner bulkhead with the supplied screws and washers.

(This page is intentionally blank.)

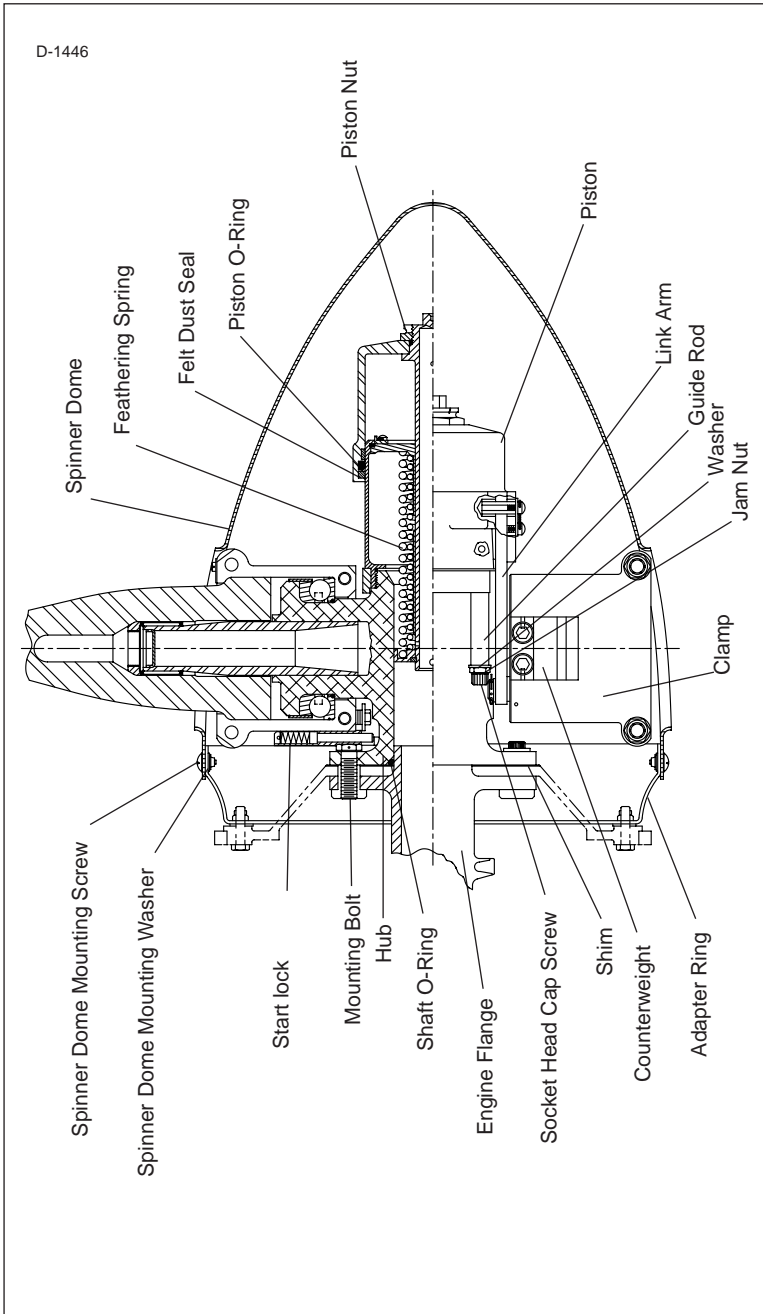

HC-A3(MV,V)K-2() Propeller Assembly
Figure 3-13

- I. Installing K Flange Propeller Models
HC-A3(MV,V)K-2() ()

Refer to Figure 3-13.

WARNING 1: TO FACILITATE BOXING AND SHIPPING OF THE PROPELLER, THE PISTON NUT MAY HAVE BEEN REMOVED IN ORDER TO ALLOW ROTATING OF THE BLADES BEFORE PACKAGING.

FOR SAFETY REASONS, IF THE PISTON NUT WAS NOT REMOVED, THE PROPELLER MUST BE PUT IN FEATHER POSITION BEFORE IT IS INSTALLED ON THE AIRCRAFT.

WARNING 2: MAKE SURE THE SLING IS RATED UP TO 800 POUNDS (363 KG) TO SUPPORT THE WEIGHT OF THE PROPELLER ASSEMBLY DURING INSTALLATION.

CAUTION 1: INSTRUCTIONS AND PROCEDURES IN THIS SECTION MAY INVOLVE PROPELLER CRITICAL PARTS. REFER TO THE INTRODUCTION CHAPTER OF THIS MANUAL FOR INFORMATION ABOUT PROPELLER CRITICAL PARTS. REFER TO THE ILLUSTRATED PARTS LIST CHAPTER OF THE APPLICABLE OVERHAUL MANUAL(S) FOR THE IDENTIFICATION OF SPECIFIC PROPELLER CRITICAL PARTS.

CAUTION 2: WHEN INSTALLING THE PROPELLER ON THE AIRCRAFT, DO NOT DAMAGE THE ICE PROTECTION SYSTEM COMPONENTS, IF APPLICABLE.

- (1) With a suitable crane hoist and sling, carefully move the propeller assembly to the aircraft engine mounting flange in preparation for installation.

WARNING: CLEANING AGENT MEK IS FLAMMABLE AND TOXIC TO THE SKIN, EYES AND RESPIRATORY TRACT. SKIN AND EYE PROTECTION ARE REQUIRED. AVOID PROLONGED CONTACT. USE IN A WELL VENTILATED AREA.

- (2) Clean the engine flange and propeller flange with Quick Dry Stoddard Solvent or MEK.
- (3) Install the spinner adapter ring on the engine starter ring gear. Refer to Figure 3-9.

CAUTION: FAILURE TO INSTALL THE SHIM BETWEEN THE PROPELLER FLANGE AND THE STARTER RING GEAR CAN RESULT IN MOUNTING BOLT FAILURE.

- (4) Install the shim (Table 3-1) on the engine shaft between the starter ring gear and the propeller flange. Refer to Figure 3-9.
- (5) Lubricate the specified shaft O-ring (Table 3-1) and install it on the engine flange.

CAUTION: USING A FELT-TIPPED PEN, IDENTIFY EACH START LOCK AND ITS ADJACENT BLADE CLAMP WITH A CORRESPONDING LETTER. THIS WILL INSURE THAT EACH START LOCK WILL BE REINSTALLED WITH THE CORRECT BLADE CLAMP TO MAINTAIN THE SAME BLADE ANGLES FOR ENGINE START.

- (6) Remove each start lock to allow access to preinstalled propeller mounting bolts.
- (7) Align the three mounting bolts (already installed in the propeller hub flange) with the threaded bushings in the engine flange.

NOTE: Three propeller mounting bolts will already be installed in the propeller flange. Interference with other propeller parts requires that the bolts be installed during propeller assembly.

CAUTION: MAKE SURE THAT COMPLETE AND TRUE SURFACE CONTACT IS ESTABLISHED BETWEEN THE PROPELLER HUB FLANGE AND THE ENGINE FLANGE.

- (8) Slide the propeller flange onto the engine flange against the starter ring gear and shim.

NOTE: Insert the engine bushings into the counterbores that encircle the propeller mounting bolts in the propeller flange.

CAUTION: NEW PROPELLER MOUNTING BOLTS MUST BE USED WHEN INITIALLY INSTALLING A NEW OR OVERHAULED PROPELLER.

- (9) Thread the three mounting bolts (Table 3-1) through the propeller flange from the propeller side, and into the bushings in the engine flange. Refer to Figure 3-9.

- (10) Install three mounting bolts in the remaining three mounting holes and thread them through the propeller flange from the propeller side, into the bushings in the engine flange. Refer to Figure 3-9.

NOTE: For propeller removals between overhaul intervals, mounting bolts and washers may be reused if they are not damaged or corroded.

- (11) Use a torque wrench with the appropriate torque wrench adapter (Figure 3-6) to torque all mounting bolts in sequence. Refer to Table 3-2 and Figure 3-4 to determine the proper torque value to which the torque wrench must be set.

NOTE: Refer to the Tools, Consumables, and Expendables section in this chapter for a list of applicable torque wrench adapters.

- (a) Torque the mounting bolts to half of the final torque, beginning with any mounting bolt, and moving around the clock in either direction.
- (b) Final torque the bolts in sequence, beginning with any mounting bolt, and moving around the clock in either direction.

- (12) Reinstall each start lock adjacent to the blade clamp that has a corresponding felt-tip marked letter.

- (13) Safety all mounting bolts with 0.032 inch (0.810 mm) minimum diameter stainless steel wire or equivalent aircraft safety cable and associated hardware (two bolts per safety).

NOTE: The mounting bolts that are adjacent to the start lock units must be safety-wired to the hex head bolts that attach the start lock brackets.

- (14) Procedure for reinstallation of the piston nut, if applicable.

- (a) Following the installation of the propeller, retract the start lock pins and hold them in place with a heavy wire inserted through the hole of each start lock housing.
- (b) Carefully push the piston toward the engine, rotating the blades to feather position, and attach the piston nut to the pitch change rod.
- (c) Use a breaker bar and a 5/8 inch deep well socket to hold the pitch change rod.
- (d) Using a 1-13/16 inch crowfoot wrench and a torque wrench, torque the piston nut. Refer to Table 3-2 and Figure 3-4 for the proper torque value.

NOTE: The removal and subsequent reinstallation of the piston nut does not require that the propeller blade angles be rechecked.

- (15) Remove the wires from the start lock brackets.

CAUTION: DO NOT PUT THE BLADE PADDLE IN THE AREA OF THE DE-ICE BOOT WHEN APPLYING TORQUE TO A BLADE ASSEMBLY. PUT THE BLADE PADDLE IN THE THICKEST AREA OF THE BLADE, JUST OUTSIDE OF THE DE-ICE BOOT. USE ONE BLADE PADDLE PER BLADE.

- (16) Position the propeller on the start locks.

- (a) Using the blade paddles, slowly rotate the blades simultaneously toward low pitch until the start lock pins engage the start lock plate.

(17) If the propeller is equipped with an ice protection system that uses components supplied by Hartzell Propeller Inc., applicable instructions and technical information for the components supplied by Hartzell Propeller Inc can be found in the following publications available on the Hartzell Propeller Inc website at www.hartzellprop.com.

- (a) Manual 180 (30-61-80) - Propeller Ice Protection System Manual
- (b) Manual 181 (30-60-81) - Propeller Ice Protection Component Maintenance Manual
- (c) Manual 182 (61-12-82) - Propeller Electrical De-ice Boot Removal and Installation Manual
- (d) Manual 183 (61-12-83) - Propeller Anti-icing Boot Removal and Installation Manual

(18) Propeller ice protection system components not supplied by Hartzell Propeller Inc. are controlled by the applicable TC or STC holder's Instructions for Continued Airworthiness (ICA).

(19) Install the spinner dome as follows:

NOTE: The following instructions relate to Hartzell Propeller Inc. spinners only. In some cases, the airframe manufacturer produced the spinner assembly. In those cases, refer to the airframe manufacturer's manual for spinner installation instructions.

CAUTION 1: TO PREVENT DAMAGE TO THE BLADE AND BLADE PAINT, WRAP THE BLADE SHANKS IN SEVERAL LAYERS OF MASKING OR DUCT TAPE BEFORE INSTALLING THE SPINNER DOME. REMOVE THE TAPE AFTER THE SPINNER IS INSTALLED.

CAUTION 2: THE SPINNER DOME WILL WOBBLE IF NOT ALIGNED PROPERLY, AND MAY AFFECT THE BALANCE OF THE PROPELLER.

- (a) Carefully slide the spinner dome over the reinstalled propeller.
- (b) Secure the spinner dome to the spinner bulkhead with the supplied screws and washers.

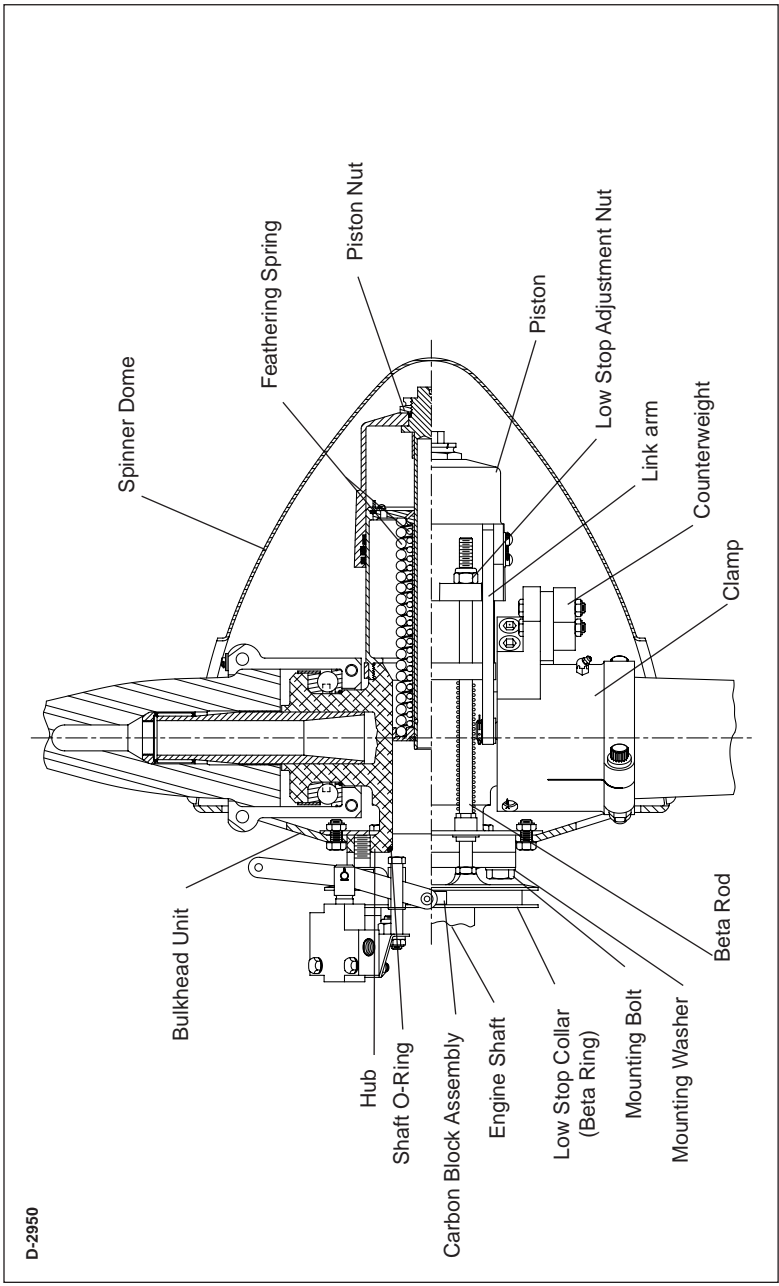

D-2850

BHC-A2(MV,V)F-3 Propeller Assembly
Figure 3-14

- J. Installing F Flange Propeller Models BHC-A2(MV,V)F-3
Refer to Figure 3-14.

- (1) Use a beta system puller CST-2987 (Figure 3-15) to compress the beta system and pull the beta ring forward to allow installation of the double hex head propeller mounting fasteners.

WARNING: MAKE SURE THE SLING IS RATED UP TO 800 POUNDS (363 KG) TO SUPPORT THE WEIGHT OF THE PROPELLER ASSEMBLY DURING INSTALLATION.

CAUTION 1: INSTRUCTIONS AND PROCEDURES IN THIS SECTION MAY INVOLVE PROPELLER CRITICAL PARTS. REFER TO THE INTRODUCTION CHAPTER OF THIS MANUAL FOR INFORMATION ABOUT PROPELLER CRITICAL PARTS. REFER TO THE ILLUSTRATED PARTS LIST CHAPTER OF THE APPLICABLE OVERHAUL MANUAL(S) FOR THE IDENTIFICATION OF SPECIFIC PROPELLER CRITICAL PARTS.

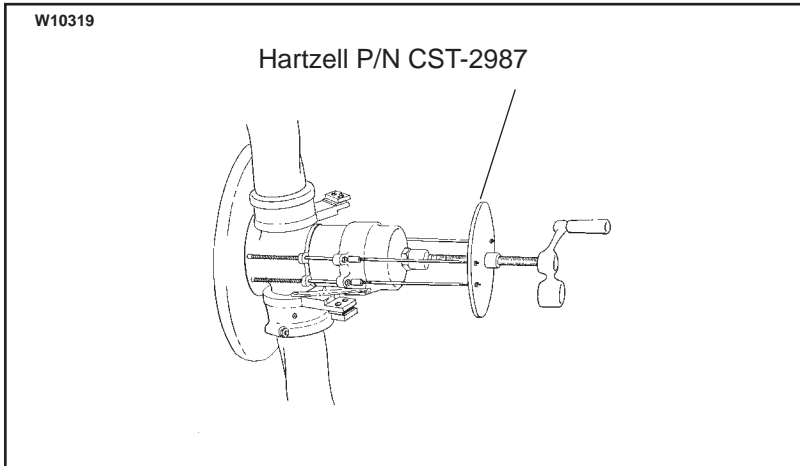

**Tool for Decompressing External Beta System
Figure 3-15**

CAUTION 2: WHEN INSTALLING THE PROPELLER ON THE AIRCRAFT, DO NOT DAMAGE THE ICE PROTECTION SYSTEM COMPONENTS, IF APPLICABLE.

- (2) With a suitable crane hoist and sling, carefully move the propeller assembly to the aircraft engine mounting flange in preparation for installation.

WARNING: CLEANING AGENT MEK IS FLAMMABLE AND TOXIC TO THE SKIN, EYES AND RESPIRATORY TRACT. SKIN AND EYE PROTECTION ARE REQUIRED. AVOID PROLONGED CONTACT. USE IN A WELL VENTILATED AREA.

- (3) Clean the engine flange and propeller flange with Quick Dry Stoddard Solvent or MEK.

CAUTION: INSERT THE DOWEL PINS INTO THE PROPELLER FLANGE USING A BRASS HAMMER OR EQUIVALENT TOOL TO PREVENT DAMAGE TO THE DOWEL PINS. THE DOWEL PINS ARE AN INTERFERENCE FIT WITH THE PROPELLER FLANGE.

- (4) Insert two dowel pins (Table 3-1) through the threadless holes in the propeller flange, flush with the propeller side of the hub flange. The dowel pins will protrude from the engine side of the hub flange to engage the engine flange.
- (5) Install the specified O-ring (Table 3-1) on the engine flange.
- (6) Align the mounting and dowel pin holes in the propeller hub flange with the mounting holes and dowel pins or mounting studs in the engine flange. Refer to Figure 3-3.
- (7) Slide the propeller flange onto the engine flange.

CAUTION 1: MAKE SURE THAT COMPLETE AND TRUE SURFACE CONTACT IS ESTABLISHED BETWEEN THE PROPELLER HUB FLANGE AND THE ENGINE FLANGE.

CAUTION 2: NEW PROPELLER MOUNTING BOLTS MUST BE USED WHEN INITIALLY INSTALLING A NEW OR OVERHAULED PROPELLER.

- (8) Install mounting bolts with washers (Table 3-1) through the engine flange and into the propeller hub flange. Refer to Figure 3-14.

NOTE: For propeller removals between overhaul intervals, mounting bolts and washers may be reused if they are not damaged or corroded.

- (9) Use a torque wrench with the appropriate torque wrench adapter (Figure 3-3) to torque all mounting bolts in sequence. Refer to Table 3-2 and Figure 3-4 to determine the proper torque value to which the torque wrench must be set.

NOTE: Refer to the Tools, Consumables, and Expendables section in this chapter for a list of applicable torque wrench adapters.

- (a) Torque the mounting bolts to half of the final torque, beginning with any mounting bolt, and moving around the clock in either direction.
- (b) Final torque the bolts in sequence, beginning with any mounting bolt, and moving around the clock in either direction.
- (10) Safety all mounting bolts with 0.032 inch (0.81 mm) minimum diameter stainless steel wire or equivalent aircraft safety cable and associated hardware (two bolts per safety).
- (11) Decompress and remove the beta system puller.
- (12) If the propeller is equipped with an ice protection system that uses components supplied by Hartzell Propeller Inc., applicable instructions and technical information for the components supplied by Hartzell Propeller Inc. can be found in the following publications available on the Hartzell Propeller Inc. website at www.hartzellprop.com.
- (a) Manual 180 (30-61-80) - Propeller Ice Protection System Manual
- (b) Manual 181 (30-60-81) - Propeller Ice Protection Component Maintenance Manual

- (c) Manual 182 (61-12-82) - Propeller Electrical De-ice Boot Removal and Installation Manual
 - (d) Manual 183 (61-12-83) - Propeller Anti-icing Boot Removal and Installation Manual
- (13) Propeller ice protection system components not supplied by Hartzell Propeller Inc. are controlled by the applicable TC or STC holder's Instructions for Continued Airworthiness (ICA).

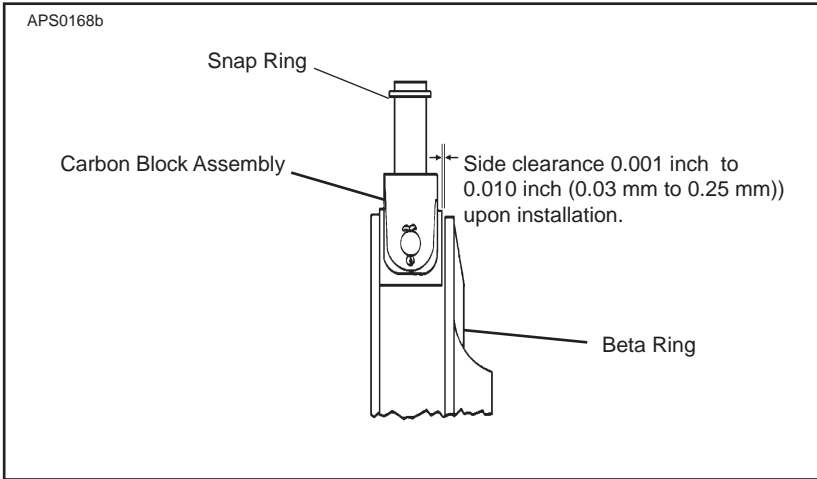

Carbon Block and Beta Ring Clearance
Figure 3-16

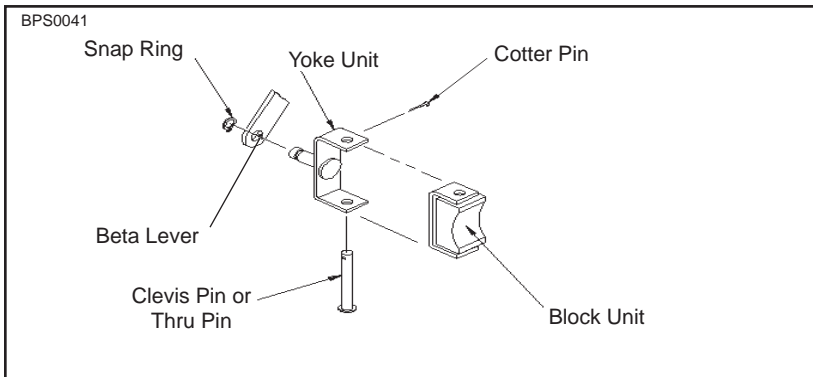

Carbon Block Assembly
Figure 3-17

D-2985F

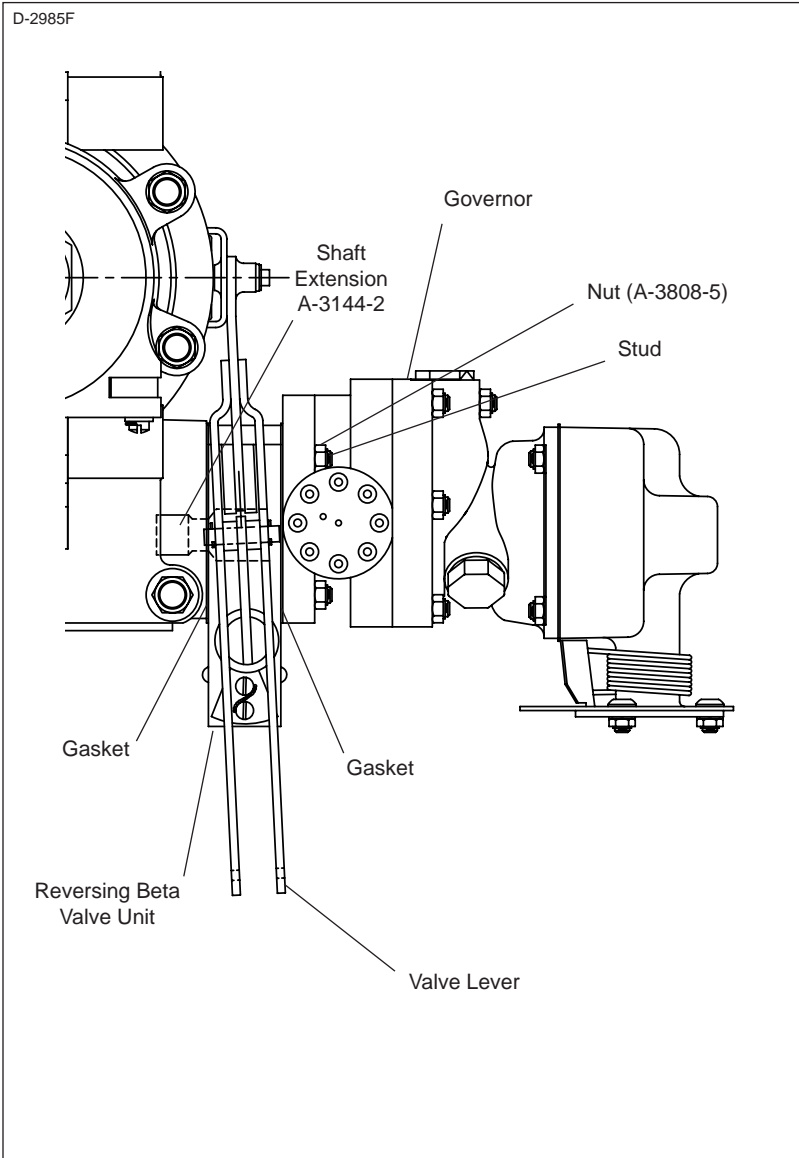

Installation of Beta Valve, Governor, and Linkage
Figure 3-18

(14) Install the spinner dome as follows:

NOTE: The following instructions relate to Hartzell spinners only. In some cases, the airframe manufacturer produced the spinner assembly. In those cases, refer to the airframe manufacturer's manual for spinner installation instructions.

CAUTION 1: TO PREVENT DAMAGE TO THE BLADE AND BLADE PAINT, WRAP THE BLADE SHANKS IN SEVERAL LAYERS OF MASKING OR DUCT TAPE BEFORE INSTALLING THE SPINNER DOME. REMOVE THE TAPE AFTER THE SPINNER IS INSTALLED.

CAUTION 2: THE SPINNER DOME WILL WOBBLE IF NOT ALIGNED PROPERLY, AND MAY AFFECT THE BALANCE OF THE PROPELLER.

(15) Carefully slide the spinner dome over the reinstalled propeller.

(16) Secure the spinner dome to the spinner bulkhead with the supplied screws and washers.

(17) Install the beta valve, governor, and linkage as follows:
Refer to Figure 3-18.

NOTE: If a governor only was previously installed, the existing studs in the engine governor pad will be too short to accommodate both a governor and beta valve. These studs must be replaced with longer length studs.

- (a) Replacement of the four studs in the engine governor pad with longer studs, or due to stud damage must be performed only by a certified mechanic in accordance with the engine manufacturer's requirements.
- (b) Install the governor gasket (Table 3-1) against the face of the engine pad.
- (c) Install the beta valve unit as shown in Figure 3-18.

- (d) Install a governor gasket (Table 3-1) against the valve face (contacting the governor).
- (e) Install the shaft extension (Table 3-1) into the splines of the engine governor drive shaft.
- (f) Install the governor and secure it with nuts (Table 3-1).

NOTE: Follow the applicable airframe manufacturer's instructions for rigging of the governor control cable.

- (g) Torque the nuts to 10-15 Ft-Lb (14-20 N•m).
- (h) Install the carbon block into the beta linkage lever, per the airframe manufacturer's instructions.

CAUTION 1: FIT THE BLOCK IN THE BETA RING WITH A MINIMUM SIDE CLEARANCE OF 0.001 INCH (0.03 MM). REFER TO FIGURE 3-16.

CAUTION 2: MAXIMUM SIDE CLEARANCE PERMITTED IS 0.010 INCH (0.25 MM) IN ACCORDANCE WITH THE CARBON BLOCK ASSEMBLIES SECTION IN THE MAINTENANCE PRACTICES CHAPTER OF THIS MANUAL.

- (i) Install the carbon block assembly (Figure 3-17) into the beta ring.
- (j) Install, adjust, and safety the beta linkage per the airframe manufacturer's instructions.

NOTE: If airframe manufacturer's instructions are unavailable, then follow step 4.I.(16).

- (k) Connect the outer end of the lever with the control push-pull fitting provided.
- (l) Secure the housing of the push-pull control to a bracket.

(18) Adjusting the Propeller Reverse Control System

NOTE: Follow the instructions in this step only if the manufacturer's instructions for this procedure are unavailable.

Refer to Figure 3-19.

- (a) Set the reverse control in forward position.
- (b) Adjust "D", at the end of the reverse control rod, so that "B" is approximately 1/16 inch (1.6 mm) as measured from the spool flange to the bottom of the counterbore (or within 1/16 inch (1.6 mm) of the end of its travel).

NOTE: "A" is zero.

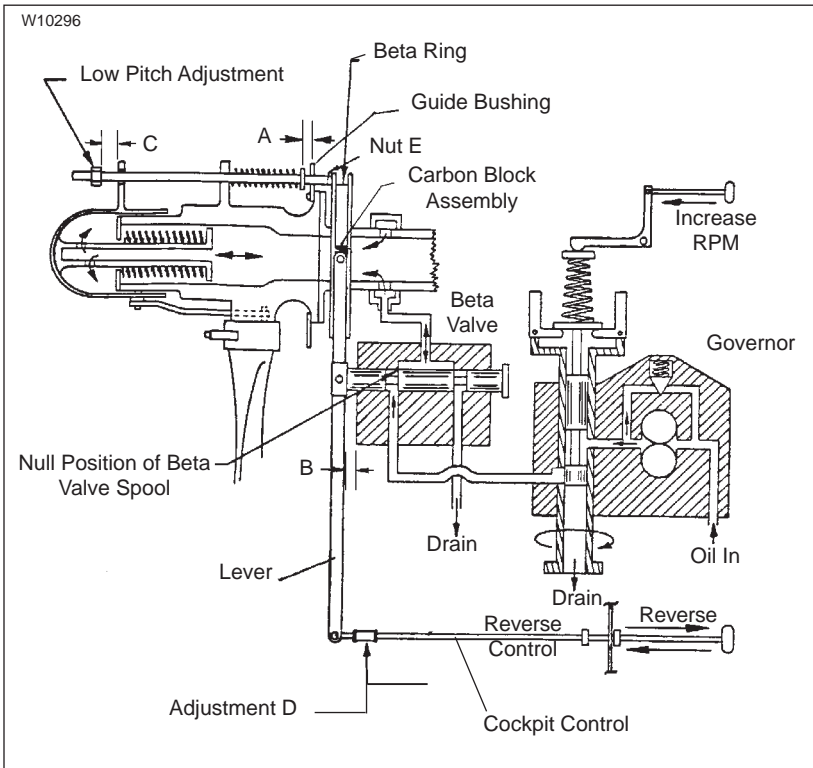

**Adjusting Propeller Reverse Control System
Figure 3-19**

- (c) The low pitch adjustment "C" has been made at the factory, according to published information. The readjustment of low pitch should not be required. Refer to the Propeller Low Pitch Settings section in the Maintenance Practices Chapter of this manual for adjustment information.

CAUTION: TO PREVENT ENGINE OVERSPEED, DO NOT ALLOW THE RPM TO REACH THE RPM SET BY THE GOVERNOR. THIS WILL ALLOW THE GOVERNOR TO OVERRIDE THE REVERSE PITCH CONTROL AND CAUSE THE PITCH TO COME OUT OF REVERSE, RESULTING IN DAMAGE TO THE REVERSING MECHANISM.

- (d) Check the RPM during reverse pitch operation.
- 1 Set the propeller governor control for maximum RPM.
 - 2 While the engine is idling, set the pitch control for maximum reverse pitch.
 - 3 Gradually open the throttle until the RPM reaches the maximum value, or until the RPM reaches approximately 80 percent to 90 percent of the engine rating.

NOTE: It is desirable to have the reverse pitch set to provide 80 percent to 90 percent of the engine rated RPM. This provides a margin of safety for reverse pitch operation.

- (e) If the RPM exceeds the desired value for reverse pitch, check to be sure the reverse push-pull control (Figure 3-19) has enough travel to move the piston up against its internal stop. To accomplish this:

CAUTION: DO NOT PUT THE BLADE PADDLE IN THE AREA OF THE DE-ICE BOOT WHEN APPLYING TORQUE TO A BLADE ASSEMBLY. PUT THE BLADE PADDLE IN THE THICKEST AREA OF THE BLADE, JUST OUTSIDE OF THE DE-ICE BOOT. USE ONE BLADE PADDLE PER BLADE.

- 1** Using blade paddles (one per blade), rotate the blade angle into full reverse pitch, and determine if the beta valve is calling for oil pressure. This condition is met if "B" (Figure 3-19) is 3/16 inch (4.8 mm) or less.
- 2** While in full reverse, check for clearance between nut "E" (Figure 3-19) and the guide bushing. There should be a positive clearance.

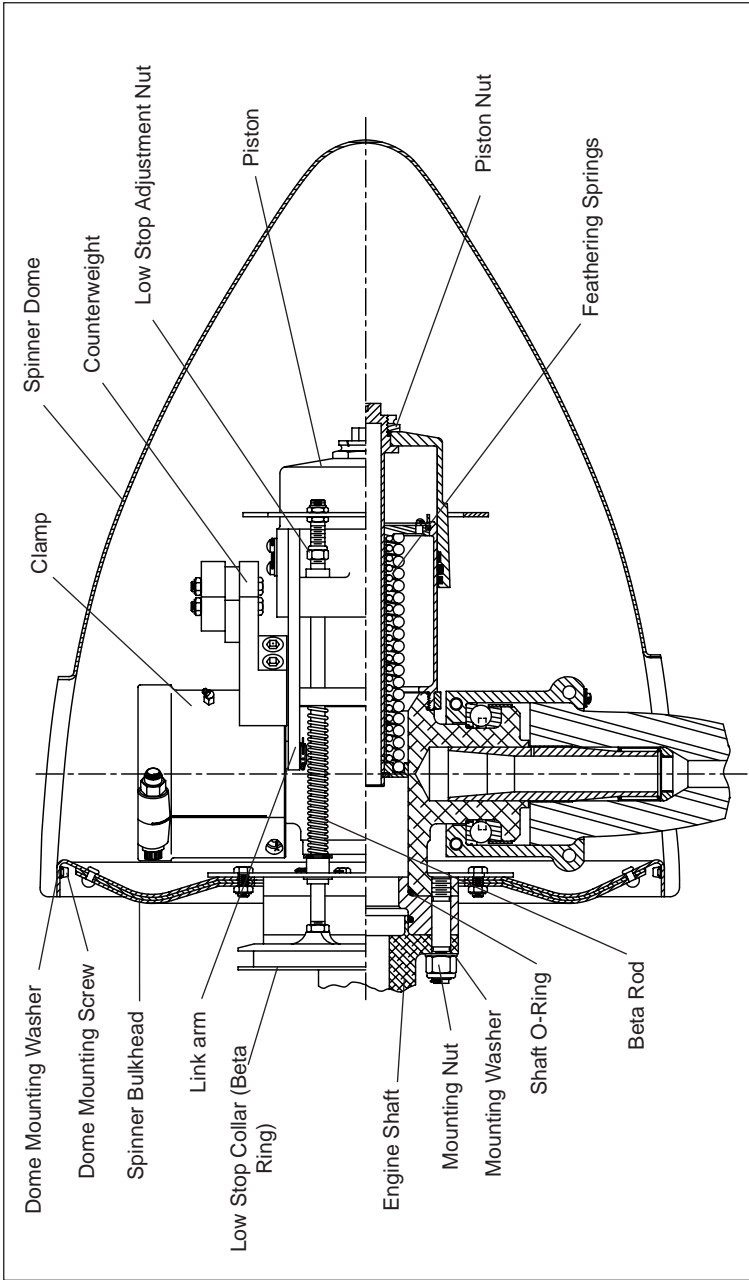

**HC-A3(MV,V)F-3L Propeller Assembly
Figure 3-20**

K. Installing F Flange Propeller Models
HC-A3(MV,V)F-3L

Refer to Figure 3-20.

- (1) Use a beta system puller CST-2987 (Figure 3-21) to compress the beta system and pull the beta ring forward to allow installation of the double hex head propeller mounting bolts.

WARNING: MAKE SURE THE SLING IS RATED UP TO 800 POUNDS (363 KG) TO SUPPORT THE WEIGHT OF THE PROPELLER ASSEMBLY DURING INSTALLATION.

CAUTION 1: INSTRUCTIONS AND PROCEDURES IN THIS SECTION MAY INVOLVE PROPELLER CRITICAL PARTS. REFER TO THE INTRODUCTION CHAPTER OF THIS MANUAL FOR INFORMATION ABOUT PROPELLER CRITICAL PARTS. REFER TO THE ILLUSTRATED PARTS LIST CHAPTER OF THE APPLICABLE OVERHAUL MANUAL(S) FOR THE IDENTIFICATION OF SPECIFIC PROPELLER CRITICAL PARTS.

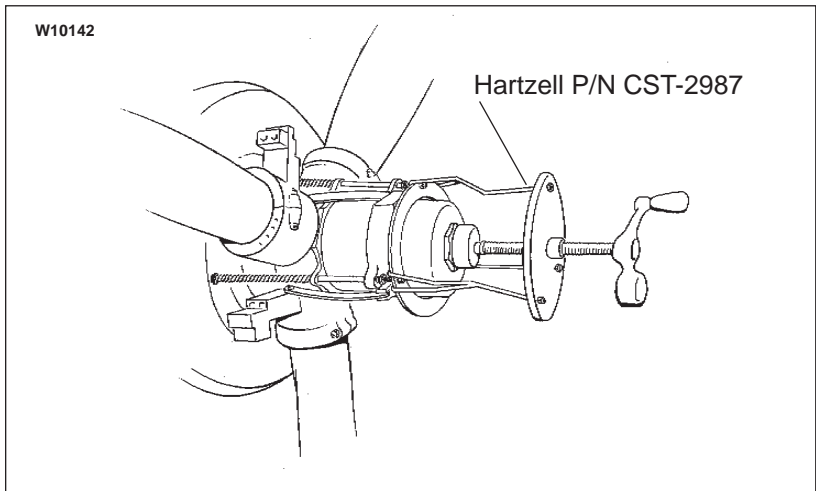

**Tool for Decompressing External Beta System
Figure 3-21**

CAUTION 2: WHEN INSTALLING THE PROPELLER ON THE AIRCRAFT, DO NOT DAMAGE THE ICE PROTECTION SYSTEM COMPONENTS, IF APPLICABLE.

(2) With a suitable crane hoist and sling, carefully move the propeller assembly to the aircraft engine mounting flange.

WARNING: CLEANING AGENT MEK IS FLAMMABLE AND TOXIC TO THE SKIN, EYES AND RESPIRATORY TRACT. SKIN AND EYE PROTECTION ARE REQUIRED. AVOID PROLONGED CONTACT. USE IN A WELL VENTILATED AREA.

(3) Clean the engine flange and propeller flange with Quick Dry Stoddard Solvent or MEK.

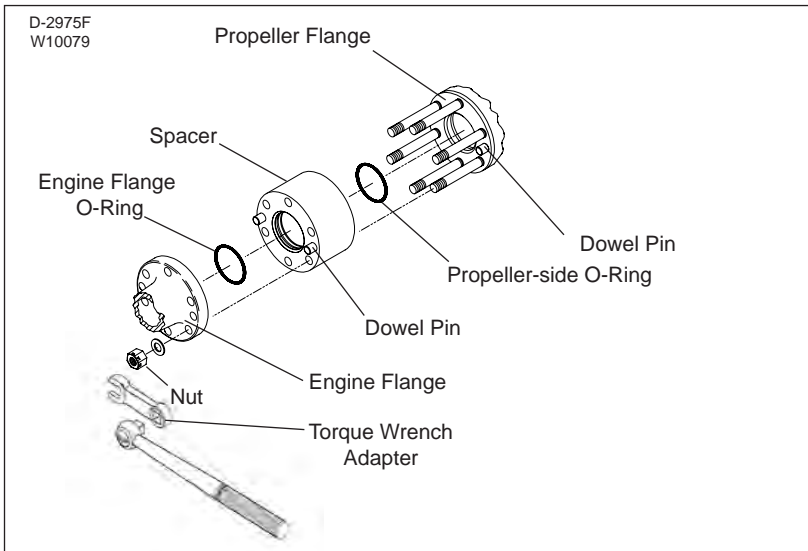

**HC-A3(MV,V)F-3L Installation
Figure 3-22**

- (4) If dowel pins are not installed in the spacer and propeller flange, perform the following steps:

CAUTION: INSERT THE DOWEL PINS INTO THE PROPELLER FLANGE USING A BRASS HAMMER OR EQUIVALENT TOOL TO PREVENT DAMAGE TO THE DOWEL PINS. THE DOWEL PINS ARE AN INTERFERENCE FIT WITH THE PROPELLER FLANGE.

- (a) Insert two dowel pins (Table 3-1) through the threadless holes in the propeller flange, flush with the propeller-side of the hub flange.

NOTE: The dowel pins will protrude from the hub flange surface facing the engine, to engage the spacer.

CAUTION: INSERT THE DOWEL PINS INTO THE SPACER USING A BRASS HAMMER OR EQUIVALENT TOOL TO PREVENT DAMAGE TO THE DOWEL PINS. THE DOWEL PINS ARE AN INTERFERENCE FIT WITH THE SPACER.

- (b) Insert two dowel pins (Table 3-1) into the dowel pin holes on the engine-side of the spacer. (Figure 3-22).

NOTE: The dowel pins must protrude 0.50 inch (12.7 mm) from the engine side of the spacer.

- (5) Install the specified O-ring (Table 3-1) on the side of the spacer, facing the propeller flange.
- (6) Align the mounting and dowel pin holes in the engine flange with the mounting studs and dowel pins in the spacer.
- (7) Slide the spacer onto the propeller flange.

CAUTION: MAKE SURE THAT COMPLETE AND TRUE SURFACE CONTACT IS ESTABLISHED BETWEEN THE PROPELLER HUB FLANGE AND THE SPACER.

- (8) Install the specified O-ring (Table 3-1) in the inside diameter groove of the spacer, facing the engine.
- (9) Align the mounting and dowel pin holes in the engine flange with the mounting studs and dowel pins in the spacer.
- (10) Slide the spacer and propeller onto the engine flange.

CAUTION 1: MAKE SURE THAT COMPLETE AND TRUE SURFACE CONTACT IS ESTABLISHED BETWEEN THE PROPELLER HUB FLANGE SPACER AND THE ENGINE FLANGE.

CAUTION 2: NEW PROPELLER NUTS AND WASHERS MUST BE USED WHEN INITIALLY INSTALLING A NEW OR OVERHAULED PROPELLER.

- (11) Install mounting washers and nuts (Table 3-1) onto the mounting studs that protrude through the engine side of the engine flange (Figure 3-22).

NOTE: For propeller removals between overhaul intervals, studs, nuts, and washers may be reused if they are not damaged or corroded.

CAUTION: MAKE SURE THE STUDS DO NOT TURN WHEN THE MOUNTING NUTS ARE TORQUED. ALLOWING THE STUDS TO TURN WILL LOAD THEM AGAINST THE SPINNER MOUNTING PLATE AND MAY LEAD TO FAILURE OF THE SPINNER MOUNTING BOLTS.

(12) Use a torque wrench with the appropriate torque wrench adapter (Figure 3-22) to torque all mounting nuts in sequence. Refer to Table 3-2 and Figure 3-4 to determine the proper torque value to which the torque wrench must be set.

NOTE: Refer to the Tools, Consumables, and Expendables section in this chapter for a list of applicable torque wrench adapters.

(a) Torque the mounting nuts to half of the final torque, beginning with any mounting nut, and moving around the clock in either direction.

(b) Final torque the mounting nuts in sequence, beginning with any mounting nut, and moving around the clock in either direction.

(13) Safety all mounting studs with 0.032 inch (0.81 mm) minimum diameter stainless steel wire or equivalent aircraft safety cable and associated hardware (two studs per safety).

(14) Decompress and remove the beta system puller.

(15) Install, adjust, and safety the beta linkage in accordance with the airframe manufacturer's instructions.

(16) If the propeller is equipped with an ice protection system that uses components supplied by Hartzell Propeller Inc., applicable instructions and technical information for the components supplied by Hartzell can be found in the following publications available on the Hartzell website at www.hartzellprop.com.

- (a) Manual 180 (30-61-80) - Propeller Ice Protection System Manual
- (b) Manual 181 (30-60-81) - Propeller Ice Protection Component Maintenance Manual
- (c) Manual 182 (61-12-82) - Propeller Electrical De-ice Boot Removal and Installation Manual
- (d) Manual 183 (61-12-83) - Propeller Anti-icing Boot Removal and Installation Manual

(17) Propeller ice protection system components not supplied by Hartzell Propeller Inc. are controlled by the applicable TC or STC holder's Instructions for Continued Airworthiness (ICA).

(18) Install the spinner dome as follows:

NOTE: The following instructions relate to Hartzell spinners only. In some cases, the airframe manufacturer produced the spinner assembly. In those cases, refer to the airframe manufacturer's manual for spinner installation instructions.

CAUTION 1: TO PREVENT DAMAGE TO THE BLADE AND BLADE PAINT, WRAP THE BLADE SHANKS IN SEVERAL LAYERS OF MASKING OR DUCT TAPE BEFORE INSTALLING THE SPINNER DOME. REMOVE THE TAPE AFTER THE SPINNER IS INSTALLED.

CAUTION 2: THE SPINNER DOME WILL WOBBLE IF NOT ALIGNED PROPERLY, AND MAY AFFECT THE BALANCE OF THE PROPELLER.

- (a) Carefully slide the spinner dome over the reinstalled propeller.
- (b) Secure the spinner dome to the spinner bulkhead with the supplied screws and washers.

- (19) Install the beta valve, governor, and linkage as follows.
Refer to Figure 3-18.

NOTE: If a governor only was previously installed, the existing studs in the engine governor pad will be too short to accommodate both a governor and beta valve. These studs must be replaced with longer length studs.

- (a) Replacement of the four studs in the engine governor pad with longer studs, or due to stud damage must be performed only by a certified mechanic in accordance with the engine manufacturer's requirements.
- (b) Install the governor gasket (Table 3-1) against the face of the engine pad.
- (c) Install the beta valve unit as shown in Figure 3-18.
- (d) Install a governor gasket (Table 3-1) against the valve face (contacting the governor).
- (e) Install the shaft extension (Table 3-1) into the female splines of the engine governor drive shaft.
- (f) Install the governor and secure it with nuts (Table 3-1).

NOTE: Follow the applicable airframe manufacturer's instructions for rigging of the governor control cable.

- (g) Torque the nuts to 10-15 Ft-Lb (14-20 N•m).
- (h) Install the carbon block into the beta linkage lever, per the airframe manufacturer's instructions.

CAUTION 1: FIT THE BLOCK IN THE BETA RING WITH A MINIMUM SIDE CLEARANCE OF 0.001 INCH (0.03 mm). REFER TO FIGURE 3-16.

CAUTION 2: MAXIMUM SIDE CLEARANCE PERMITTED IS 0.010 INCH (0.25 mm) IN ACCORDANCE WITH THE CARBON BLOCK ASSEMBLIES SECTION IN THE MAINTENANCE PRACTICES CHAPTER OF THIS MANUAL.

- (i) Install the carbon block assembly (Figure 3-17) into the beta ring.

- (j) Install, adjust, and safety the beta linkage per the airframe manufacturer's instructions.

NOTE: If airframe manufacturer's instructions are unavailable, then follow step 4.J.(18).

- (k) Connect the outer end of the lever with the control push-pull fitting provided.
- (l) Secure the housing of the push-pull control to a bracket.

(18) Adjusting the Propeller Reverse Control System

NOTE: Follow the instructions in this step only if the manufacturer's instructions for this procedure are unavailable.

Refer to Figure 3-19.

- (a) Set the reverse control in forward position.
- (b) Adjust "D", at the end of the reverse control rod, so that "B" is approximately 1/16 inch (1.6 mm) as measured from the spool flange to the bottom of the counterbore (or within 1/16 inch (1.6 mm) of the end of its travel).

NOTE: "A" is zero.

- (c) The low pitch adjustment "C" has been made at the factory, according to published information. The readjustment of low pitch should not be required. Refer to the Propeller Low Pitch Settings section in the Maintenance Practices Chapter of this manual for adjustment information.

CAUTION: TO PREVENT ENGINE OVERSPEED, DO NOT ALLOW THE RPM TO REACH THE RPM SET BY THE GOVERNOR. THIS WILL ALLOW THE GOVERNOR TO OVERRIDE THE REVERSE PITCH CONTROL AND CAUSE THE PITCH TO COME OUT OF REVERSE, RESULTING IN DAMAGE TO THE REVERSING MECHANISM.

(d) Check the RPM during reverse pitch operation.

- 1 Set the propeller governor control for maximum RPM.
- 2 While the engine is idling, set the pitch control for maximum reverse pitch.
- 3 Gradually open the throttle until the RPM reaches the maximum value, or until the RPM reaches approximately 80 percent to 90 percent of the engine rating.

NOTE: It is desirable to have the reverse pitch set to provide 80 percent to 90 percent of the engine rated RPM. This provides a margin of safety for reverse pitch operation.

- (e) If the RPM exceeds the desired value for reverse pitch, check to be sure the reverse push-pull control (Figure 3-19) has enough travel to move the piston up against its internal stop. To accomplish this:

CAUTION: DO NOT PUT THE BLADE PADDLE IN THE AREA OF THE DE-ICE BOOT WHEN APPLYING TORQUE TO A BLADE ASSEMBLY. PUT THE BLADE PADDLE IN THE THICKEST AREA OF THE BLADE, JUST OUTSIDE OF THE DE-ICE BOOT. USE ONE BLADE PADDLE PER BLADE.

- 1** Using blade paddles (one per blade), rotate the blade angle into full reverse pitch, and determine if the beta valve is calling for oil pressure. This condition is met if "B" (Figure 3-19) is 3/16 inch (4.8 mm) or less.
- 2** While in full reverse, check for clearance between nut "E" (Figure 3-19) and the guide bushing. There should be a positive clearance.

(This page is intentionally blank.)

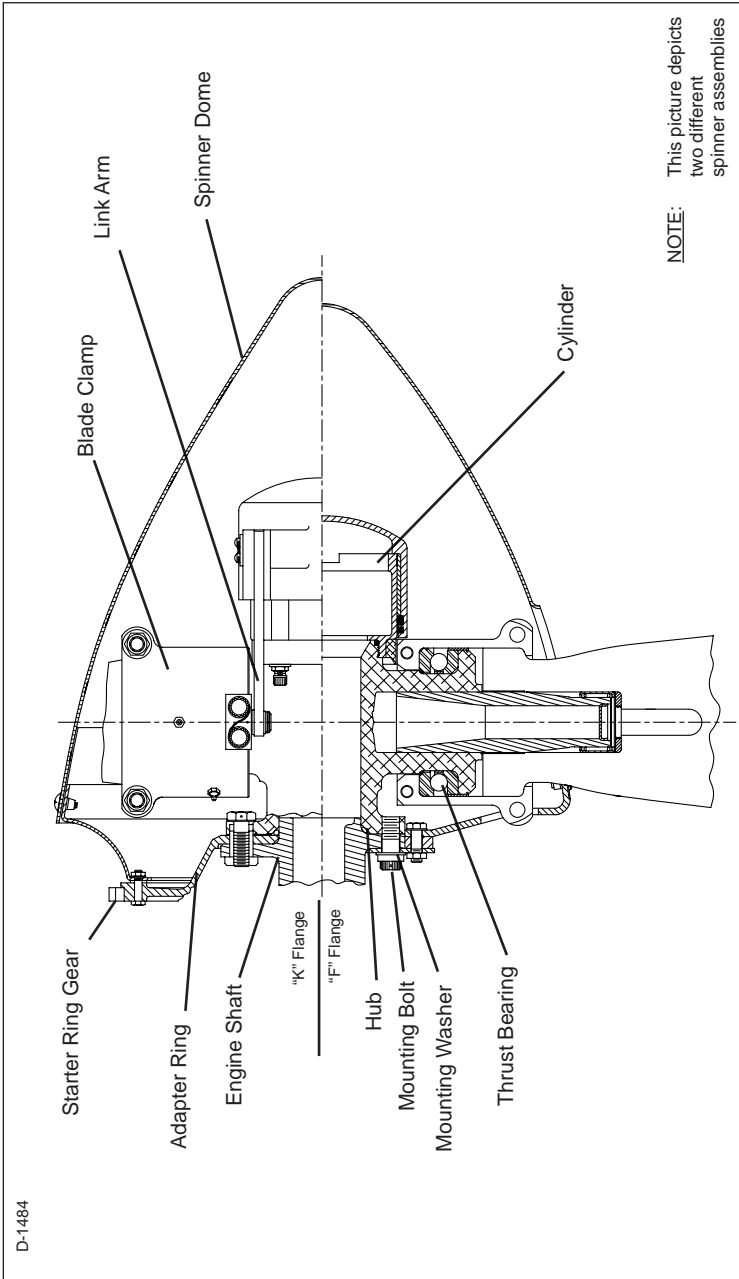

(E,P)HC-A3(MV,V)(F,K)-4() Propeller Assembly
Figure 3-23

- L. Installing F Flange Propeller Models (E,P)HC-A3(MV,V)F-4()
Refer to Figure 3-23.

CAUTION 1: INSTRUCTIONS AND PROCEDURES IN THIS SECTION MAY INVOLVE PROPELLER CRITICAL PARTS. REFER TO THE INTRODUCTION CHAPTER OF THIS MANUAL FOR INFORMATION ABOUT PROPELLER CRITICAL PARTS. REFER TO THE ILLUSTRATED PARTS LIST CHAPTER OF THE APPLICABLE OVERHAUL MANUAL(S) FOR THE IDENTIFICATION OF SPECIFIC PROPELLER CRITICAL PARTS.

CAUTION 2: INSERT THE DOWEL PINS INTO THE PROPELLER FLANGE USING A BRASS HAMMER OR EQUIVALENT TOOL TO PREVENT DAMAGE TO THE DOWEL PINS. THE DOWEL PINS ARE AN INTERFERENCE FIT WITH THE PROPELLER FLANGE.

- (1) Insert two dowel pins (Table 3-1) through the threadless holes in the propeller flange, flush with the propeller side of the hub flange. The dowel pins will protrude from the engine side of the hub flange to engage the engine flange.

WARNING: MAKE SURE THE SLING IS RATED UP TO 800 POUNDS (363 KG) TO SUPPORT THE WEIGHT OF THE PROPELLER ASSEMBLY DURING INSTALLATION.

CAUTION: WHEN INSTALLING THE PROPELLER ON THE AIRCRAFT, DO NOT DAMAGE THE ICE PROTECTION SYSTEM COMPONENTS, IF APPLICABLE.

- (2) With a suitable crane hoist and sling, carefully move the propeller assembly to the aircraft engine mounting flange in preparation for installation.

WARNING: CLEANING AGENT MEK IS FLAMMABLE AND TOXIC TO THE SKIN, EYES AND RESPIRATORY TRACT. SKIN AND EYE PROTECTION ARE REQUIRED. AVOID PROLONGED CONTACT. USE IN A WELL VENTILATED AREA.

- (3) Clean the engine flange and propeller flange with Quick Dry Stoddard Solvent or MEK.
- (4) PHC-A3(MV,V)F-4() Models only:
 - (a) Slide the ring for the spinner mounting onto the engine flange.
 - (b) Position the two piece plate (Table 3-1) against the engine side of the engine flange.
 - (c) Position the spinner bulkhead on the propeller side of the ring for the spinner mounting.
 - (d) Install the hex head bolts from the propeller side, through four holes in the bulkhead, adapter ring, and two piece plates to secure all three together.
 - (e) Install the washer and nut on each bolt from the engine side.
 - (f) Torque the nuts to 8-12 Ft-Lb (11-16 N•m).
- (5) Lubricate the specified shaft O-ring (Table 3-1) and install it on the engine shaft.
- (6) Align the threaded holes of the propeller flange with the bolt holes in the engine flange, and align the dowel pins in the propeller flange with the dowel pin holes in the engine flange.

CAUTION 1: MAKE SURE THAT COMPLETE AND TRUE SURFACE CONTACT IS ESTABLISHED BETWEEN THE PROPELLER HUB FLANGE AND THE ENGINE FLANGE.

CAUTION 2: USE CARE TO AVOID SCRAPING ALUMINUM FROM THE BORE OF THE SPINNER BULKHEAD. SCRAPINGS COULD BECOME WEDGED BETWEEN THE FLANGES.

- (7) Slide the propeller onto the engine shaft.

CAUTION: NEW PROPELLER MOUNTING BOLTS MUST BE USED WHEN INITIALLY INSTALLING A NEW OR OVERHAULED PROPELLER.

- (8) Install six mounting bolts (Table 3-1) with washers through the spinner mounting plate and the engine flange and into the tapped holes in the propeller flange.

NOTE: For propeller removals between overhaul intervals, mounting bolts and washers may be reused if they are not damaged or corroded.

- (9) Use a torque wrench with the appropriate torque wrench adapter (Figure 3-6) to torque all mounting bolts in sequence. Refer to Table 3-2 and Figure 3-4 to determine the proper torque value to which the torque wrench must be set.

NOTE: Refer to the Tools, Consumables, and Expendables section in this chapter for a list of applicable torque wrench adapters.

- (a) Torque the mounting bolts to half of the final torque, beginning with any mounting bolt, and moving around the clock in either direction.
- (b) Final torque the bolts in sequence, beginning with any mounting bolt, and moving around the clock in either direction.

- (10) Safety all mounting bolts with 0.032 inch (0.81 mm) minimum diameter stainless steel wire or equivalent aircraft safety cable and associated hardware (two bolts per safety).

- (11) If the propeller is equipped with an ice protection system that uses components supplied by Hartzell Propeller Inc., applicable instructions and technical information for the components supplied by Hartzell Propeller Inc. can be found in the following publications available on the Hartzell Propeller Inc. website at www.hartzellprop.com.

- (a) Manual 180 (30-61-80) - Propeller Ice Protection System Manual
- (b) Manual 181 (30-60-81) - Propeller Ice Protection Component Maintenance Manual

- (c) Manual 182 (61-12-82) - Propeller Electrical De-ice Boot Removal and Installation Manual
 - (d) Manual 183 (61-12-83) - Propeller Anti-icing Boot Removal and Installation Manual
- (12) Propeller ice protection system components not supplied by Hartzell Propeller Inc. are controlled by the applicable TC or STC holder's Instructions for Continued Airworthiness (ICA).
- (13) Install the spinner dome as follows:

CAUTION 1: TO PREVENT DAMAGE TO THE BLADE AND BLADE PAINT, WRAP THE BLADE SHANKS IN SEVERAL LAYERS OF MASKING OR DUCT TAPE BEFORE INSTALLING THE SPINNER DOME. REMOVE THE TAPE AFTER THE SPINNER IS INSTALLED.

CAUTION 2: THE SPINNER DOME WILL WOBBLE IF NOT ALIGNED PROPERLY, AND MAY AFFECT THE BALANCE OF THE PROPELLER.

NOTE 1: The following instructions relate to Hartzell spinners only. In some cases, the airframe manufacturer produced the spinner assembly. In those cases, refer to the airframe manufacturer's manual for spinner installation instructions.

NOTE 2: No spinner dome is installed on the EHC-A3(MV,V)F-4 propeller model.

- (a) Carefully slide the spinner dome over the reinstalled propeller.
- (b) Attach the spinner dome to the spinner bulkhead with the supplied screws and washers.

- M. Installing K Flange Propeller Models HC-A3(MV,V)K-4
Refer to Figure 3-23.

WARNING: MAKE SURE THE SLING IS RATED UP TO 800 POUNDS (363 KG) TO SUPPORT THE WEIGHT OF THE PROPELLER ASSEMBLY DURING INSTALLATION.

CAUTION 1: INSTRUCTIONS AND PROCEDURES IN THIS SECTION MAY INVOLVE PROPELLER CRITICAL PARTS. REFER TO THE INTRODUCTION CHAPTER OF THIS MANUAL FOR INFORMATION ABOUT PROPELLER CRITICAL PARTS. REFER TO THE ILLUSTRATED PARTS LIST CHAPTER OF THE APPLICABLE OVERHAUL MANUAL(S) FOR THE IDENTIFICATION OF SPECIFIC PROPELLER CRITICAL PARTS.

CAUTION 2: WHEN INSTALLING THE PROPELLER ON THE AIRCRAFT, DO NOT DAMAGE THE ICE PROTECTION SYSTEM COMPONENTS, IF APPLICABLE.

- (1) With a suitable crane hoist and sling, carefully move the propeller assembly to the aircraft engine mounting flange in preparation for installation.

WARNING: CLEANING AGENT MEK IS FLAMMABLE AND TOXIC TO THE SKIN, EYES AND RESPIRATORY TRACT. SKIN AND EYE PROTECTION ARE REQUIRED. AVOID PROLONGED CONTACT. USE IN A WELL VENTILATED AREA.

- (2) Clean the engine flange and propeller flange with Quick Dry Stoddard Solvent or MEK.
- (3) Install the spinner adapter ring on the engine starter ring gear. Refer to Figure 3-5.
- (4) Align the blade openings in the adapter ring to the propeller blade positions.

CAUTION: FAILURE TO INSTALL THE SHIM BETWEEN THE PROPELLER FLANGE AND THE STARTER RING GEAR CAN RESULT IN MOUNTING BOLT FAILURE.

- (5) Install the shim (Table 3-1) on the engine shaft between the starter ring gear and the propeller flange. Refer to Figure 3-5.
- (6) Lubricate the specified shaft O-ring (Table 3-1) and install it on the engine flange. Refer to Figure 3-5.
- (7) Align the three mounting bolts (already installed in the propeller hub flange) with the threaded bushings in the engine flange.

NOTE: Three propeller mounting bolts will already be installed in the propeller flange. Interference with other propeller parts requires that the bolts be installed during propeller assembly.

CAUTION: MAKE SURE THAT COMPLETE AND TRUE SURFACE CONTACT IS ESTABLISHED BETWEEN THE PROPELLER HUB FLANGE AND THE ENGINE FLANGE.

- (8) Slide the propeller flange onto the engine flange against the starter ring gear and shim.

NOTE: Insert the engine bushings into the counterbores that encircle the propeller mounting bolts in the propeller flange.

CAUTION: NEW PROPELLER MOUNTING BOLTS MUST BE USED WHEN INITIALLY INSTALLING A NEW OR OVERHAULED PROPELLER.

- (9) Thread the three mounting bolts (Table 3-1) through the propeller flange from the propeller side, and into the bushings in the engine flange. Refer to Figures 3-5 and 3-6.

NOTE: For propeller removals between overhaul intervals, mounting bolts and washers may be reused if they are not damaged or corroded.

- (10) Use a torque wrench with the appropriate torque wrench adapter (Figure 3-6) to torque all mounting bolts in sequence. Refer to Table 3-2 and Figure 3-4 to determine the proper torque value to which the torque wrench must be set.

NOTE: Refer to the Tools, Consumables, and Expendables section in this chapter for a list of applicable torque wrench adapters.

- (a) Torque the mounting bolts to half of the final torque, beginning with any mounting bolt, and moving around the clock in either direction.
- (b) Final torque the bolts in sequence, beginning with any mounting bolt, and moving around the clock in either direction.
- (11) Safety all mounting bolts with 0.032 inch (0.81 mm) minimum diameter stainless steel wire or equivalent aircraft safety cable and associated hardware (two bolts per safety).
- (12) If the propeller is equipped with an ice protection system that uses components supplied by Hartzell Propeller Inc., applicable instructions and technical information for the components supplied by Hartzell Propeller Inc. can be found in the following publications available on the Hartzell Propeller Inc. website at www.hartzellprop.com.
- (a) Manual 180 (30-61-80) - Propeller Ice Protection System Manual
- (b) Manual 181 (30-60-81) - Propeller Ice Protection Component Maintenance Manual
- (c) Manual 182 (61-12-82) - Propeller Electrical De-ice Boot Removal and Installation Manual
- (d) Manual 183 (61-12-83) - Propeller Anti-icing Boot Removal and Installation Manual
- (13) Propeller ice protection system components not supplied by Hartzell Propeller Inc. are controlled by the applicable TC or STC holder's Instructions for Continued Airworthiness (ICA).

(14) Install the spinner dome as follows:

NOTE: The following instructions relate to Hartzell spinners only. In some cases, the airframe manufacturer produced the spinner assembly. In those cases, refer to the airframe manufacturer's manual for spinner installation instructions.

CAUTION 1: TO PREVENT DAMAGE TO THE BLADE AND BLADE PAINT, WRAP THE BLADE SHANKS IN SEVERAL LAYERS OF MASKING OR DUCT TAPE BEFORE INSTALLING THE SPINNER DOME. REMOVE THE TAPE AFTER THE SPINNER IS INSTALLED.

CAUTION 2: THE SPINNER DOME WILL WOBBLE IF NOT ALIGNED PROPERLY, AND MAY AFFECT THE BALANCE OF THE PROPELLER.

- (a) Carefully slide the spinner dome over the reinstalled propeller.
- (b) Secure the spinner dome to the spinner bulkhead with the supplied screws and washers.

(This page is intentionally blank.)

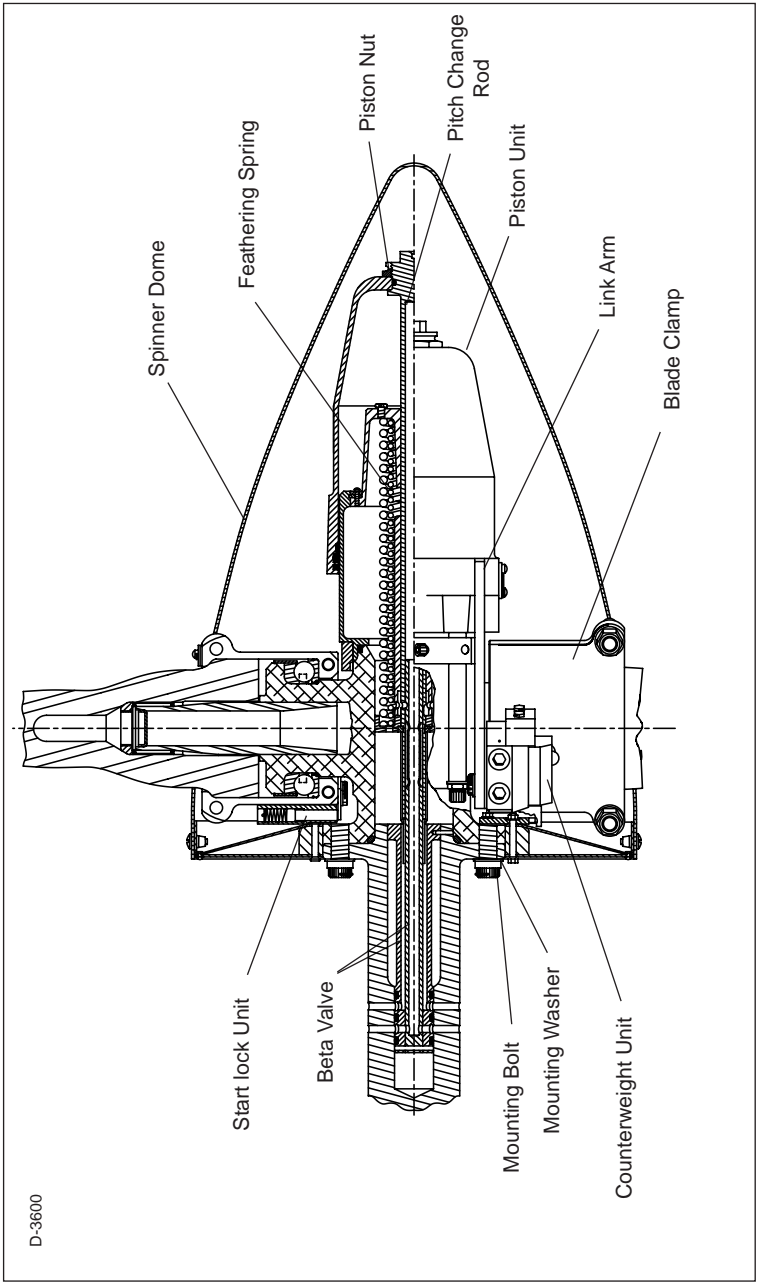

D-3600

HC-A3(MV,V)F-5A(L) Propeller Assembly
Figure 3-24

N. Installing F Flange Propeller Models
HC-A3(MV,V)F-5A(L)

Refer to Figure 3-24.

- (1) Install the beta valve inside the engine shaft. Refer to the engine manufacturer's instructions.

WARNING: MAKE SURE THE SLING IS RATED UP TO 800 POUNDS (363 KG) TO SUPPORT THE WEIGHT OF THE PROPELLER ASSEMBLY DURING INSTALLATION.

CAUTION 1: INSTRUCTIONS AND PROCEDURES IN THIS SECTION MAY INVOLVE PROPELLER CRITICAL PARTS. REFER TO THE INTRODUCTION CHAPTER OF THIS MANUAL FOR INFORMATION ABOUT PROPELLER CRITICAL PARTS. REFER TO THE ILLUSTRATED PARTS LIST CHAPTER OF THE APPLICABLE OVERHAUL MANUAL(S) FOR THE IDENTIFICATION OF SPECIFIC PROPELLER CRITICAL PARTS.

CAUTION 2: WHEN INSTALLING THE PROPELLER ON THE AIRCRAFT, DO NOT DAMAGE THE ICE PROTECTION SYSTEM COMPONENTS, IF APPLICABLE.

- (2) With a suitable crane hoist and sling, carefully move the propeller assembly to the aircraft engine mounting flange.

WARNING: CLEANING AGENT MEK IS FLAMMABLE AND TOXIC TO THE SKIN, EYES AND RESPIRATORY TRACT. SKIN AND EYE PROTECTION ARE REQUIRED. AVOID PROLONGED CONTACT. USE IN A WELL VENTILATED AREA.

- (3) Clean the engine flange and propeller flange with Quick Dry Stoddard Solvent or MEK.
- (4) Install the specified O-ring on the engine flange. Refer to Table 3-1.
- (5) Align the mounting and dowel pin holes in the engine flange with the mounting holes and dowel pins in the propeller hub flange.

CAUTION 1: MAKE SURE THAT COMPLETE AND TRUE SURFACE CONTACT IS ESTABLISHED BETWEEN THE PROPELLER HUB FLANGE AND THE ENGINE FLANGE.

CAUTION 2: MAKE SURE THE PITCH CHANGE ROD ACCURATELY ALIGNS WITH THE ENGINE-MOUNTED BETA VALVE. MISALIGNMENT WILL DAMAGE THE BETA VALVE AND/OR THE PITCH CHANGE ROD.

(6) Slide the propeller onto the engine flange.

CAUTION: NEW PROPELLER MOUNTING BOLTS MUST BE USED WHEN INITIALLY INSTALLING A NEW OR OVERHAULED PROPELLER.

(7) Install the mounting bolts with washers through the engine flange and into the propeller hub flange. Refer to Figure 3-24.

NOTE: If the propeller is removed between overhaul intervals, mounting bolts and washers may be reused if they are not damaged or corroded.

(8) Use a torque wrench with the appropriate torque wrench adapter to torque all mounting bolts in sequences and steps shown in Figure 3-3. Refer to Table 3-2 and Figure 3-4 to determine the proper torque value.

NOTE: Refer to the Tools, Consumables, and Expendables section in this chapter for a list of applicable torque wrench adapters.

(a) Torque the mounting bolts to half of the final torque, beginning with any mounting bolt, and moving around the clock in either direction.

(b) Final torque the bolts in sequence, beginning with any mounting bolt, and moving around the clock in either direction.

(9) Safety all mounting bolts with 0.032 inch (0.81 mm) minimum diameter stainless steel wire or equivalent aircraft safety cable and associated hardware (two bolts per safety).

(10) Install the beta tube per the airframe and/or engine manufacturer's instructions.

NOTE 1: Follow the airframe manufacturer's instructions for adjusting the beta tube to obtain the correct low pitch (flight idle blade angle).

NOTE 2: Refer to the Aircraft Type Certificate Data Sheet for the low pitch blade angle setting.

(11) If the propeller is equipped with an ice protection system that uses components supplied by Hartzell Propeller Inc., applicable instructions and technical information for the components supplied by Hartzell can be found in the following publications available on the Hartzell website at www.hartzellprop.com.

- (a) Manual 180 (30-61-80) - Propeller Ice Protection System Manual
- (b) Manual 181 (30-60-81) - Propeller Ice Protection Component Maintenance Manual
- (c) Manual 182 (61-12-82) - Propeller Electrical De-ice Boot Removal and Installation Manual
- (d) Manual 183 (61-12-83) - Propeller Anti-icing Boot Removal and Installation Manual

(12) Propeller ice protection system components not supplied by Hartzell Propeller Inc. are controlled by the applicable TC or STC holder's Instructions for Continued Airworthiness (ICA).

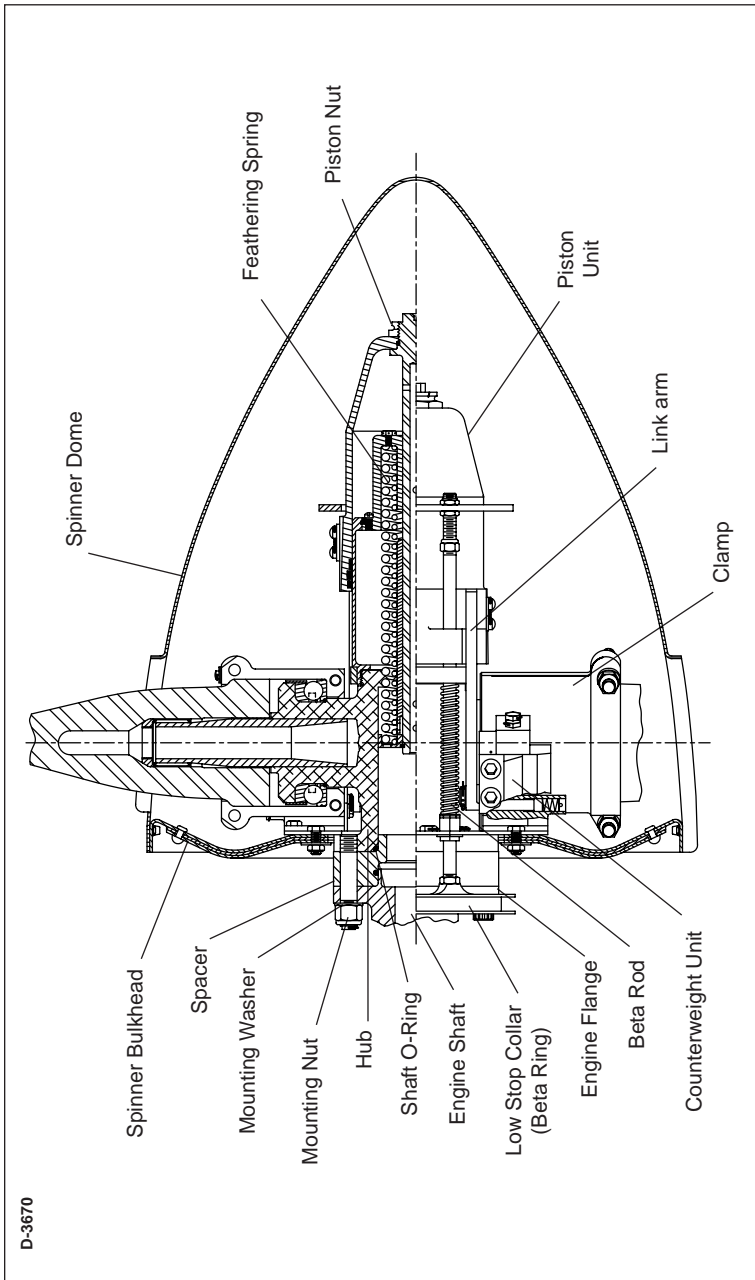

D-3670

**(P)HC-A3(MV,V)F-5R Propeller Assembly
Figure 3-25**

O. Installing F Flange Propeller Models
(P)HC-A3(MV,V)F-5R

Refer to Figure 3-25.

- (1) Use a beta system puller CST-2987 (Figure 3-15) to compress the beta system and pull the beta ring forward to allow installation of the propeller mounting nuts and washers.

WARNING: MAKE SURE THE SLING IS RATED UP TO 800 POUNDS (363 KG) TO SUPPORT THE WEIGHT OF THE PROPELLER ASSEMBLY DURING INSTALLATION.

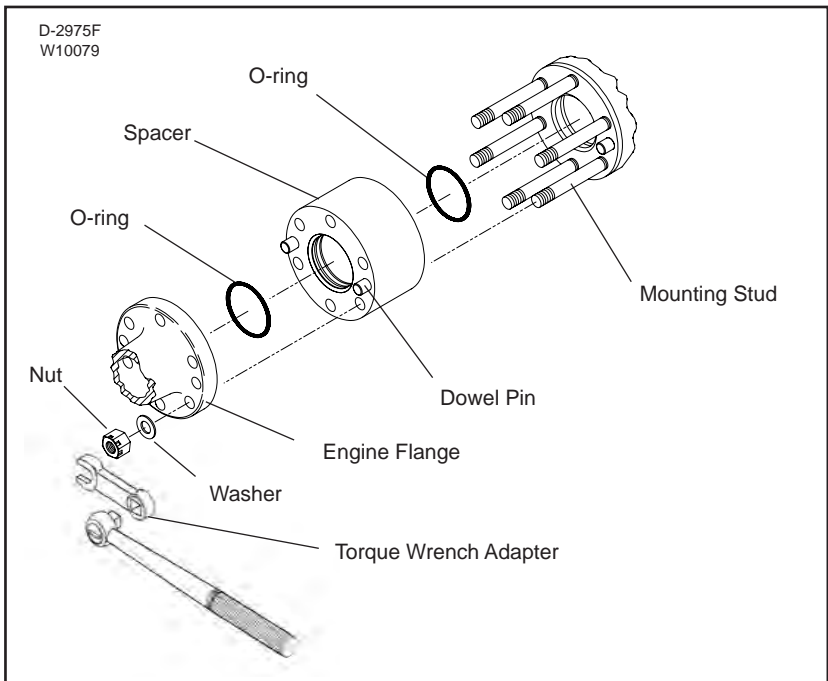

**(P)HC-A3(MV,V)F-5R Installation
Figure 3-26**

CAUTION 1: INSTRUCTIONS AND PROCEDURES IN THIS SECTION MAY INVOLVE PROPELLER CRITICAL PARTS. REFER TO THE INTRODUCTION CHAPTER OF THIS MANUAL FOR INFORMATION ABOUT PROPELLER CRITICAL PARTS. REFER TO THE ILLUSTRATED PARTS LIST CHAPTER OF THE APPLICABLE OVERHAUL MANUAL(S) FOR THE IDENTIFICATION OF SPECIFIC PROPELLER CRITICAL PARTS.

CAUTION 2: WHEN INSTALLING THE PROPELLER ON THE AIRCRAFT, DO NOT DAMAGE THE ICE PROTECTION SYSTEM COMPONENTS, IF APPLICABLE.

- (2) With a suitable crane hoist and sling, carefully move the propeller assembly to the aircraft engine mounting flange in preparation for installation.

WARNING: CLEANING AGENT MEK IS FLAMMABLE AND TOXIC TO THE SKIN, EYES AND RESPIRATORY TRACT. SKIN AND EYE PROTECTION ARE REQUIRED. AVOID PROLONGED CONTACT. USE IN A WELL VENTILATED AREA.

- (3) Clean the engine flange and propeller flange with Quick Dry Stoddard Solvent or MEK.
- (4) If dowel pins are not installed in the spacer and propeller flange, perform the following steps:

CAUTION: INSERT THE DOWEL PINS INTO THE PROPELLER FLANGE USING A BRASS HAMMER OR EQUIVALENT TOOL TO PREVENT DAMAGE TO THE DOWEL PINS. THE DOWEL PINS ARE AN INTERFERENCE FIT WITH THE PROPELLER FLANGE.

- (a) Insert two dowel pins (Table 3-1) through the threadless holes in the propeller flange, flush with the propeller-side of the hub flange.

NOTE: The dowel pins will protrude from the hub flange surface facing the engine, to engage the spacer.

CAUTION: INSERT THE DOWEL PINS INTO THE SPACER USING A BRASS HAMMER OR EQUIVALENT TOOL TO PREVENT DAMAGE TO THE DOWEL PINS. THE DOWEL PINS ARE AN INTERFERENCE FIT WITH THE SPACER.

- (b) Insert two dowel pins (Table 3-1) into the dowel pin holes on the engine-side of the spacer. (Figure 3-26).

NOTE: The dowel pins must protrude 0.50 inch (12.7 mm) from the engine side of the spacer.

- (5) Install the specified O-ring (Table 3-1) on the side of the spacer, facing the propeller flange.
- (6) Align the mounting and dowel pin holes in the spacer with the mounting studs and dowel pins in the propeller flange.
- (7) Slide the spacer onto the propeller flange.

CAUTION: MAKE SURE THAT COMPLETE AND TRUE SURFACE CONTACT IS ESTABLISHED BETWEEN THE PROPELLER HUB FLANGE AND THE SPACER.

- (8) Install the specified O-ring (Table 3-1) in the inside diameter groove of the spacer, facing the engine.

CAUTION: MAKE SURE THAT COMPLETE AND TRUE SURFACE CONTACT IS ESTABLISHED BETWEEN THE ENGINE HUB FLANGE AND THE SPACER.

- (9) Align the mounting and dowel pin holes in the engine flange with the mounting studs and dowel pins in the spacer.

CAUTION: NEW PROPELLER MOUNTING NUTS AND WASHERS MUST BE USED WHEN INITIALLY INSTALLING A NEW OR OVERHAULED PROPELLER.

(10) Install mounting washers and nuts (Table 3-1) onto the protruding studs in the engine flange. Refer to Figure 3-26.

NOTE: For propeller removals between overhaul intervals, mounting studs, nuts and washers may be reused if they are not damaged or corroded.

CAUTION: MAKE SURE THE STUDS DO NOT TURN WHEN THE NUTS ARE TORQUED. ALLOWING THE STUDS TO TURN WILL LOAD THEM AGAINST THE SPINNER MOUNTING PLATE AND MAY LEAD TO FAILURE OF THE SPINNER MOUNTING BOLTS.

(11) Use a torque wrench with the appropriate torque wrench adapter (Figure 3-3) to torque all mounting nuts in sequence. Refer to Table 3-2 and Figure 3-4 to determine the proper torque value to which the torque wrench must be set.

NOTE: Refer to the Tools, Consumables, and Expendables section in this chapter for a list of applicable torque wrench adapters.

- (a) Torque the mounting nuts to half of the final torque, beginning with any mounting bolt, and moving around the clock in either direction.
- (b) Final torque the nuts in sequence, beginning with any mounting nut, and moving around the clock in either direction.

(12) Safety all mounting studs with 0.032 inch (0.81 mm) minimum diameter stainless steel wire or equivalent aircraft safety cable and associated hardware (two studs per safety).

(13) If the propeller is equipped with an ice protection system that uses components supplied by Hartzell Propeller Inc., applicable instructions and technical information for the components supplied by Hartzell can be found in the following publications available on the Hartzell website at www.hartzellprop.com.

- (a) Manual 180 (30-61-80) - Propeller Ice Protection System Manual
- (b) Manual 181 (30-60-81) - Propeller Ice Protection Component Maintenance Manual
- (c) Manual 182 (61-12-82) - Propeller Electrical De-ice Boot Removal and Installation Manual.
- (d) Manual 183 (61-12-83) - Propeller Anti-icing Boot Removal and Installation Manual

(14) Propeller ice protection system components not supplied by Hartzell Propeller Inc. are controlled by the applicable TC or STC holder's Instructions for Continued Airworthiness (ICA).

(15) Install the spinner dome as follows:

NOTE: The following instructions relate to Hartzell spinners only. In some cases, the airframe manufacturer produced the spinner assembly. In those cases, refer to the airframe manufacturer's manual for spinner installation instructions.

CAUTION 1: TO PREVENT DAMAGE TO THE BLADE AND BLADE PAINT, WRAP THE BLADE SHANKS IN SEVERAL LAYERS OF MASKING OR DUCT TAPE BEFORE INSTALLING THE SPINNER DOME. REMOVE THE TAPE AFTER THE SPINNER IS INSTALLED.

CAUTION 2: THE SPINNER DOME WILL WOBBLE IF NOT ALIGNED PROPERLY, AND MAY AFFECT THE BALANCE OF THE PROPELLER.

- (a) Carefully slide the spinner dome over the reinstalled propeller.
- (b) Secure the spinner dome to the spinner bulkhead with the supplied screws and washers.

- I (16) Install the beta valve, governor, and linkage as follows:
Refer to Figure 3-18.

NOTE: If a governor only was previously installed, the existing studs in the engine governor pad will be too short to accommodate both a governor and beta valve. These studs must be replaced with longer length studs.

- (a) Replacement of the four studs in the engine governor pad with longer studs, or due to stud damage must be performed only by a certified mechanic in accordance with the engine manufacturer's requirements.
- (b) Install the governor gasket (Table 3-1) against the face of the engine pad.
- (c) Install the beta valve unit as shown in Figure 3-18.
- (d) Install a governor gasket (Table 3-1) against the valve face (contacting the governor).
- (e) Install the shaft extension (Table 3-1) into the female splines of the engine governor drive shaft.
- (f) Install the governor and secure it with nuts (Table 3-1).

NOTE: Follow the applicable airframe manufacturer's instructions or the supplemental type certificate holder's instructions for the rigging of the governor control cable.

- (g) Torque the nuts to 10-15 Ft-Lb (14-20 N•m).
- (h) Install the carbon block into the beta linkage lever, per the airframe manufacturer's instructions.

CAUTION 1: FIT THE BLOCK IN THE BETA RING WITH A MINIMUM SIDE CLEARANCE OF 0.001 INCH (0.03 MM). REFER TO FIGURE 3-16.

CAUTION 2: MAXIMUM SIDE CLEARANCE PERMITTED IS 0.010 INCH (0.25 mm) IN ACCORDANCE WITH THE CARBON BLOCK ASSEMBLIES SECTION IN THE MAINTENANCE PRACTICES CHAPTER OF THIS MANUAL.

- (i) Install the carbon block assembly (Figure 3-17) into the beta ring.
- (j) Install, adjust and safety the beta linkage per the airframe manufacturer's instructions.

NOTE: If airframe manufacturer's or supplemental type certificate holder's instructions are unavailable, then follow step 4.N.(15) in this chapter.

- (k) Connect the outer end of the lever with the control push-pull fitting provided.

(17) Adjusting the Propeller Reverse Control System

NOTE: Follow the instructions in this step only if the airframe manufacturer's or the supplemental type certificate holder's instructions for this procedure are unavailable.

Refer to Figure 3-19.

- (a) Set the reverse control in forward position.
- (b) Adjust "D", at the end of the reverse control rod, so that "B" is approximately 1/16 inch (1.6 mm) as measured from the spool flange to the bottom of the counterbore (or within 1/16 inch (1.6 mm) of the end of its travel).

NOTE: "A" is zero.

- (c) The low pitch adjustment "C" has been made at the factory, according to published information. The readjustment of low pitch should not be required. Refer to the Propeller Low Pitch Settings section in the Maintenance Practices Chapter of this manual for adjustment information.

CAUTION: TO PREVENT ENGINE OVERSPEED, DO NOT ALLOW THE RPM TO REACH THE RPM SET BY THE GOVERNOR. THIS WILL ALLOW THE GOVERNOR TO OVERRIDE THE REVERSE PITCH CONTROL AND CAUSE THE PITCH TO COME OUT OF REVERSE, RESULTING IN DAMAGE TO THE REVERSING MECHANISM.

- (d) Check the RPM during reverse pitch operation.
- 1 Set the propeller governor control for maximum RPM.
 - 2 While the engine is idling, set the pitch control for maximum reverse pitch.
 - 3 Gradually open the throttle until the RPM reaches the maximum value, or until the RPM reaches approximately 80 percent to 90 percent of the engine rating.

NOTE: It is desirable to have the reverse pitch set to provide 80 percent to 90 percent of the engine rated RPM. This provides a margin of safety for reverse pitch operation.

- (e) If the RPM exceeds the desired value for reverse pitch, check to be sure the reverse push-pull control (Figure 3-19) has enough travel to move the piston up against its internal stop. To accomplish this:

CAUTION: DO NOT PUT THE BLADE PADDLE IN THE AREA OF THE DE-ICE BOOT WHEN APPLYING TORQUE TO A BLADE ASSEMBLY. PUT THE BLADE PADDLE IN THE THICKEST AREA OF THE BLADE, JUST OUTSIDE OF THE DE-ICE BOOT. USE ONE BLADE PADDLE PER BLADE.

- 1 Using blade paddles (one per blade), rotate the blade angle into full reverse pitch, and determine if the beta valve is calling for oil pressure. This condition is met if "B" (Figure 3-19) is 3/16 inch (4.8 mm) or less.
- 2 While in full reverse, check for clearance between nut "E" (Figure 3-19) and the guide bushing. There should be a positive clearance.

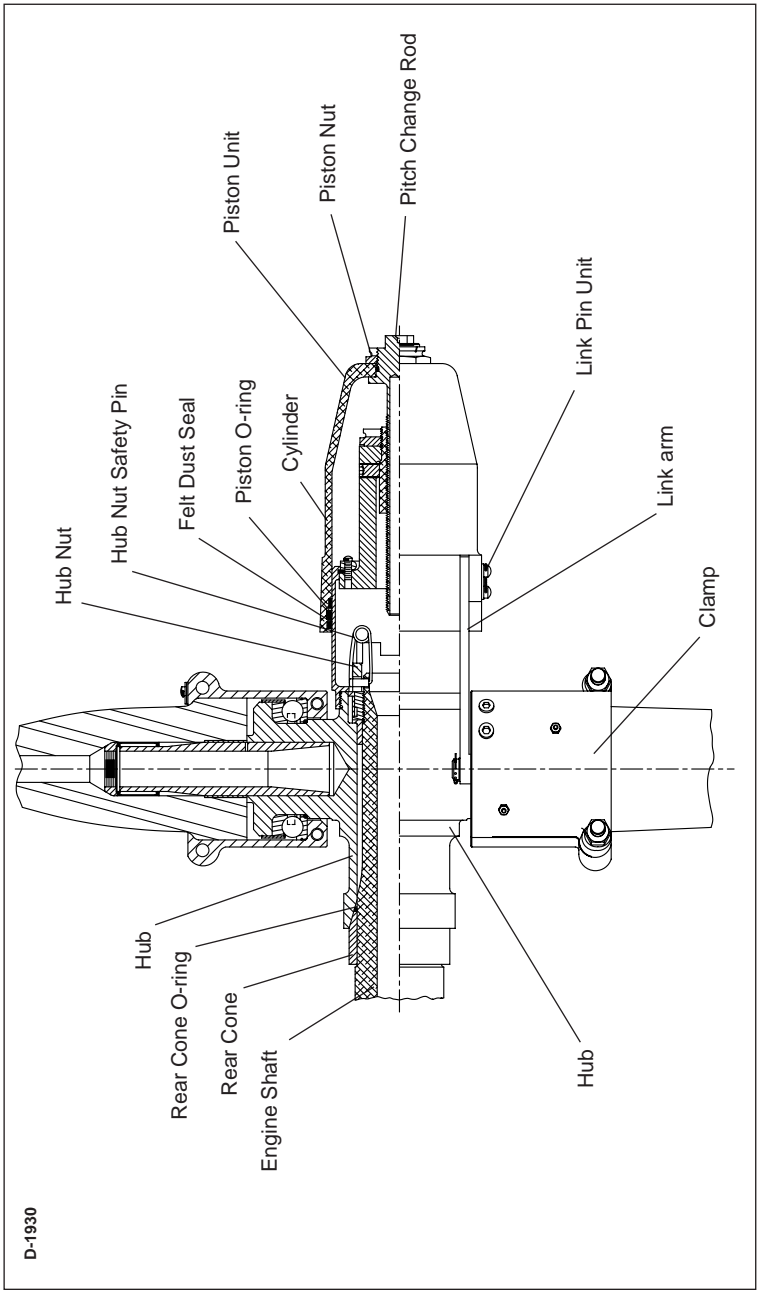

D-1930

HA-A2(MV,V)20-1B Propeller Assembly
Figure 3-27

- P. Installing Splined Propeller Models HA-A2(MV,V)20-1B
Refer to Figure 3-27.

WARNING: MAKE SURE THE SLING IS RATED UP TO 800 POUNDS (363 KG) TO SUPPORT THE WEIGHT OF THE PROPELLER ASSEMBLY DURING INSTALLATION.

CAUTION 1: INSTRUCTIONS AND PROCEDURES IN THIS SECTION MAY INVOLVE PROPELLER CRITICAL PARTS. REFER TO THE INTRODUCTION CHAPTER OF THIS MANUAL FOR INFORMATION ABOUT PROPELLER CRITICAL PARTS. REFER TO THE ILLUSTRATED PARTS LIST CHAPTER OF THE APPLICABLE OVERHAUL MANUAL(S) FOR THE IDENTIFICATION OF SPECIFIC PROPELLER CRITICAL PARTS.

CAUTION 2: WHEN INSTALLING THE PROPELLER ON THE AIRCRAFT, DO NOT DAMAGE THE ICE PROTECTION SYSTEM COMPONENTS, IF APPLICABLE.

- (1) With a suitable crane hoist and sling, carefully move the propeller assembly to the aircraft engine mounting shaft.

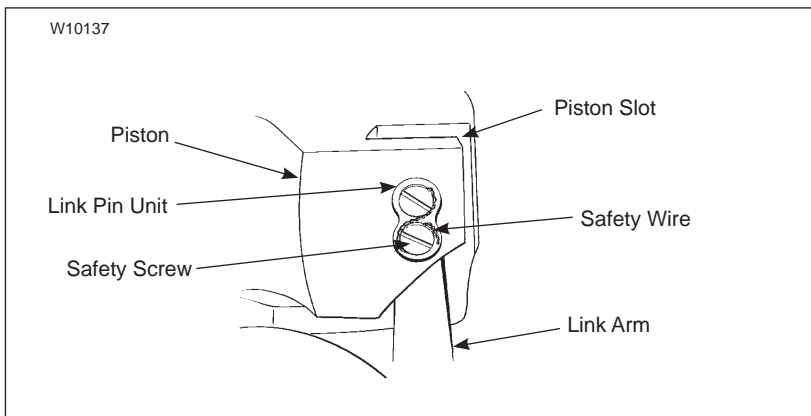

**Piston-to-Link Arm Attachment Details
Figure 3-28**

CAUTION: THE PISTON MUST BE REMOVED BEFORE INSTALLING THE PROPELLER ON THE AIRCRAFT. IF THE PISTON HAS ALREADY BEEN REMOVED, PROCEED TO STEP 4.O.(3).

- (2) Piston Removal (Refer to Figures 3-27 and 3-28.)
- (a) Remove the piston nut.
 - (b) Remove the safety wire (if installed) from the link pin units.
 - (c) Remove the safety screw from each link pin unit.
 - (d) Remove each link pin unit.

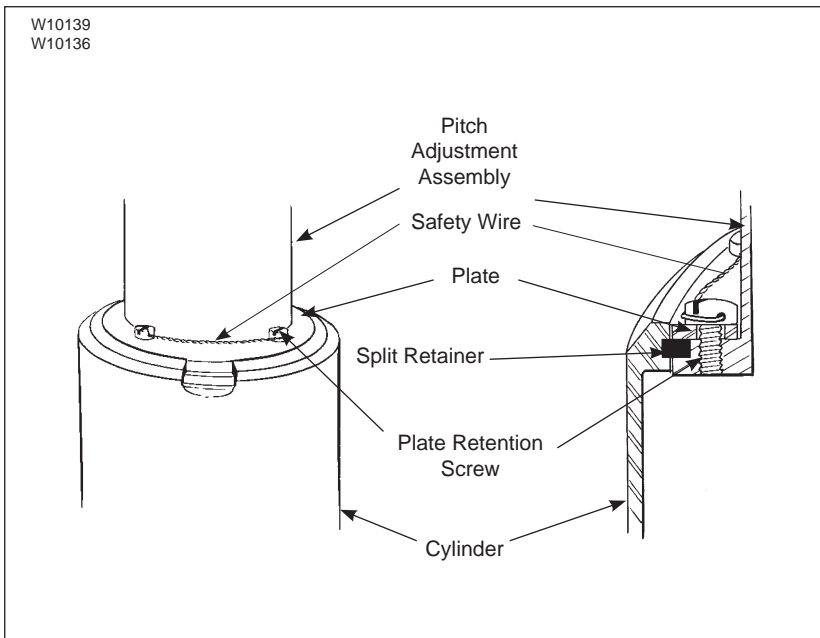

Pitch Adjustment Assembly-to-Cylinder Attachment Details
Figure 3-29

- (e) The piston ears and link arms should have corresponding index numbers (1 and 2) impression-stamped or marked with a felt-tipped pen. If they are not marked, number them with a felt-tipped pen.

NOTE: This will insure that the components are reassembled in their original location.

- (f) Slide the link arms out of the piston slots.
- (g) Slide the piston off the cylinder.

CAUTION: THE PITCH ADJUSTMENT ASSEMBLY MUST BE REMOVED BEFORE INSTALLING THE PROPELLER ON THE AIRCRAFT. IF THE PITCH ADJUSTMENT ASSEMBLY HAS ALREADY BEEN REMOVED, PROCEED TO STEP 4.O.(4).

(3) Pitch adjustment assembly removal

Refer to Figure 3-29.

- (a) Remove the plate retention screw safety wire (if installed).
- (b) Remove the plate retention screws.
- (c) Remove the plate.
- (d) Remove the split retainer.
- (e) Remove the pitch adjustment assembly from the cylinder.

WARNING: CLEANING AGENT MEK IS FLAMMABLE AND TOXIC TO THE SKIN, EYES AND RESPIRATORY TRACT. SKIN AND EYE PROTECTION ARE REQUIRED. AVOID PROLONGED CONTACT. USE IN A WELL VENTILATED AREA.

- (4) Clean the propeller hub spline and engine spline surfaces with Quick Dry Stoddard Solvent or MEK.
- (5) Slide the spinner bulkhead onto the shaft.

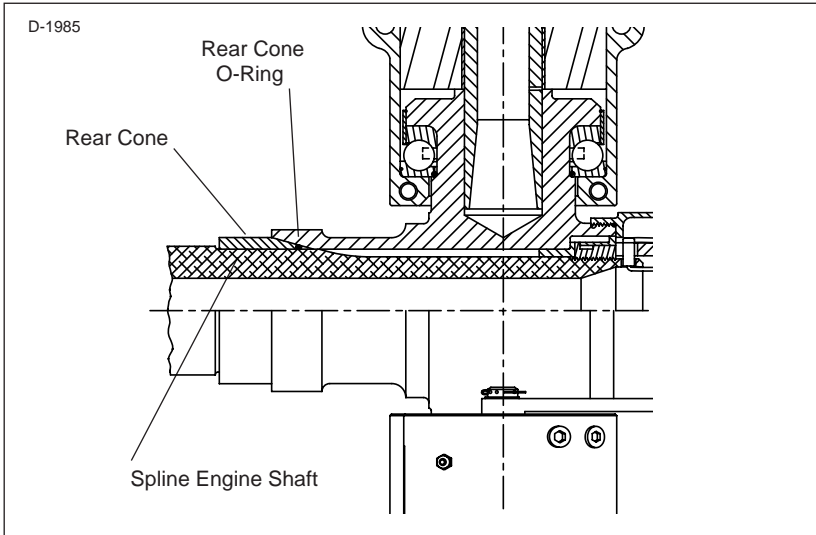

**Rear Hub Mounting Parts on HA-A2(MV,V)20-1B Propeller
Figure 3-30**

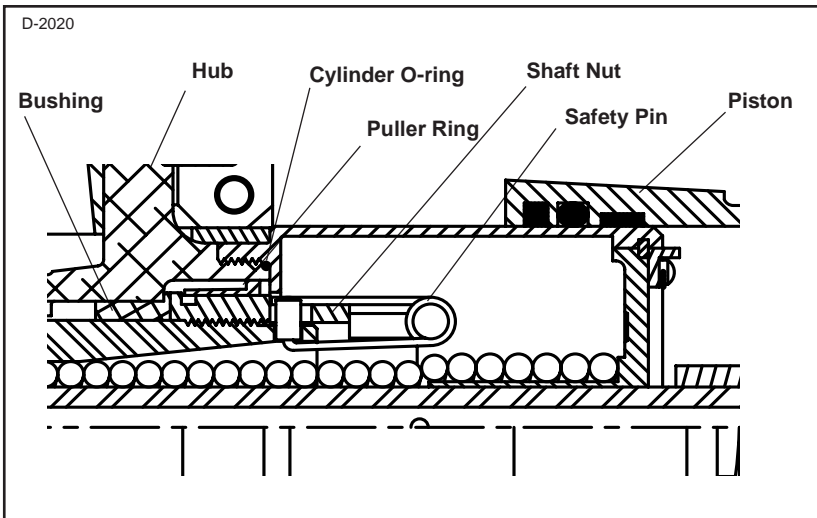

**Safetying the Shaft Nut on the 20 Spline Shaft Propeller
Figure 3-31**

- (6) Install the rear cone onto the engine, with the tapered end of the cone facing the propeller hub (Figure 3-30).
 - (7) Install the rear cone O-ring (Table 3-1) over the shaft. Refer to Figure 3-30.
 - (8) Slide the propeller hub onto the engine shaft and tighten the shaft nut.
 - (9) Torque the propeller shaft nut using tool BST-2910. Refer to Table 3-2 and Figure 3-4 to determine the proper torque value to which the torque wrench must be set.
 - (10) Safety the shaft nut (Table 3-1) to the engine shaft with a hub nut safety pin (Table 3-1). Refer to Figure 3-31.
- NOTE:** The hub nut safety pin is normally supplied in a separate package when the propeller is shipped new from the factory.
- (11) Install the pitch adjustment assembly into the cylinder.
 - (12) Install the split retainer into the recess in the cylinder.
 - (13) Pull the pitch adjustment assembly forward, tight against the split retainer, locking the split retainer into place.

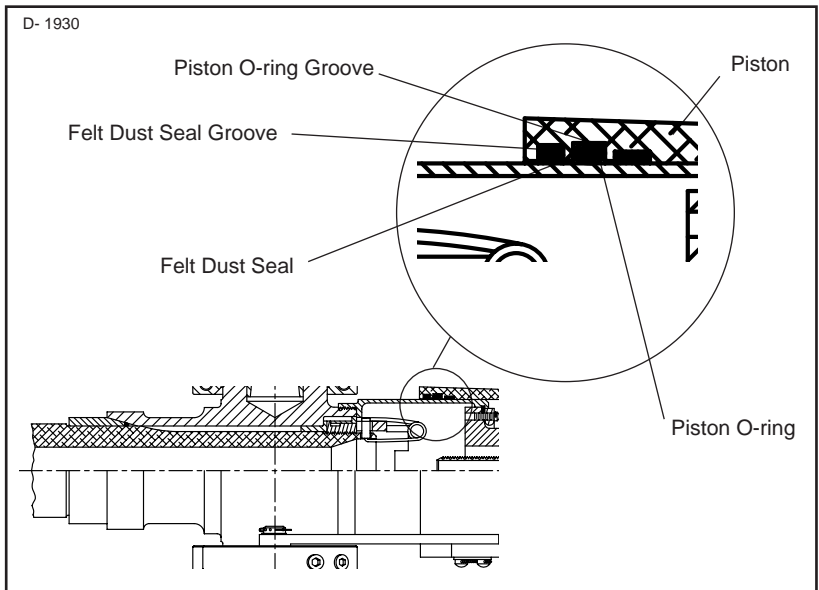

Installing Piston O-Ring and Felt Dust Seal
Figure 3-32

- (14) Install the ring retention plate, which secures the split retainer, into place.
- (15) Install the plate retention screws and tighten them until snug.
- (16) Safety the plate screws using 0.032 inch (0.81 mm) minimum diameter stainless steel wire (two screws per safety).
- (17) If the piston O-ring (Table 3-1) and the felt dust seal are not already installed in the piston, perform the following steps. Refer to Figure 3-32.
 - (a) Lubricate the piston O-ring and carefully install it in the inner groove provided for it in the piston.
 - (b) Cut the felt dust seal material to the necessary length.
NOTE: Cut the felt dust seal material on a 30 degree diagonal so there will be an overlap with a smooth, fuzz-free surface.
 - (c) Soak the felt dust seal material in aviation grade reciprocating engine oil until it is completely saturated.
 - (d) Squeeze the excess oil from the felt dust seal.
 - (e) Install the felt dust seal material in the outer groove provided for it in the piston.
 - (f) Install the rod O-ring (Table 3-1) in the groove at the end of the threaded portion of the pitch change rod.

CAUTION: TO MAINTAIN PROPER BLADE ANGLES, REINSTALL THE PISTON IN THE SAME POSITION AS WHEN IT WAS ORIGINALLY ASSEMBLED. INDEX NUMBERS ON THE PISTON AND THE GUIDE COLLAR ARE PROVIDED TO INSURE PROPER POSITIONING.

- (18) Locate and match up the index numbers (1 and 2) on the piston ears with the corresponding index numbers on the guide collar.

NOTE: The index marks will be either impression-stamped or drawn with a felt-tipped pen.

- (19) Oil the surface of the cylinder.
- (20) Slide the piston onto the cylinder.

- (21) Slide the link arms into the piston slots.
- (22) Connect the link arms to the piston.
- (23) Install the link pin units.
- (24) Install the link pin safety screws.
- (25) Safety the link pin screws together with 0.032 inch (0.81 mm) minimum diameter stainless steel wire (Figure 3-28).
- (26) Rotate the blades to a higher pitch to seat the piston onto the pitch change rod.
- (27) Install the piston nut. Torque per Table 3-2.
- (28) If the propeller is equipped with an ice protection system that uses components supplied by Hartzell Propeller Inc., applicable instructions and technical information for the components supplied by Hartzell can be found in the following publications available on the Hartzell website at www.hartzellprop.com.
 - (a) Manual 180 (30-61-80) - Propeller Ice Protection System Manual
 - (b) Manual 181 (30-60-81) - Propeller Ice Protection Component Maintenance Manual
 - (c) Manual 182 (61-12-82) - Propeller Electrical De-ice Boot Removal and Installation Manual
 - (d) Manual 183 (61-12-83) - Propeller Anti-icing Boot Removal and Installation Manual
- (29) Propeller ice protection system components not supplied by Hartzell Propeller Inc. are controlled by the applicable TC or STC holder's Instructions for Continued Airworthiness (ICA).

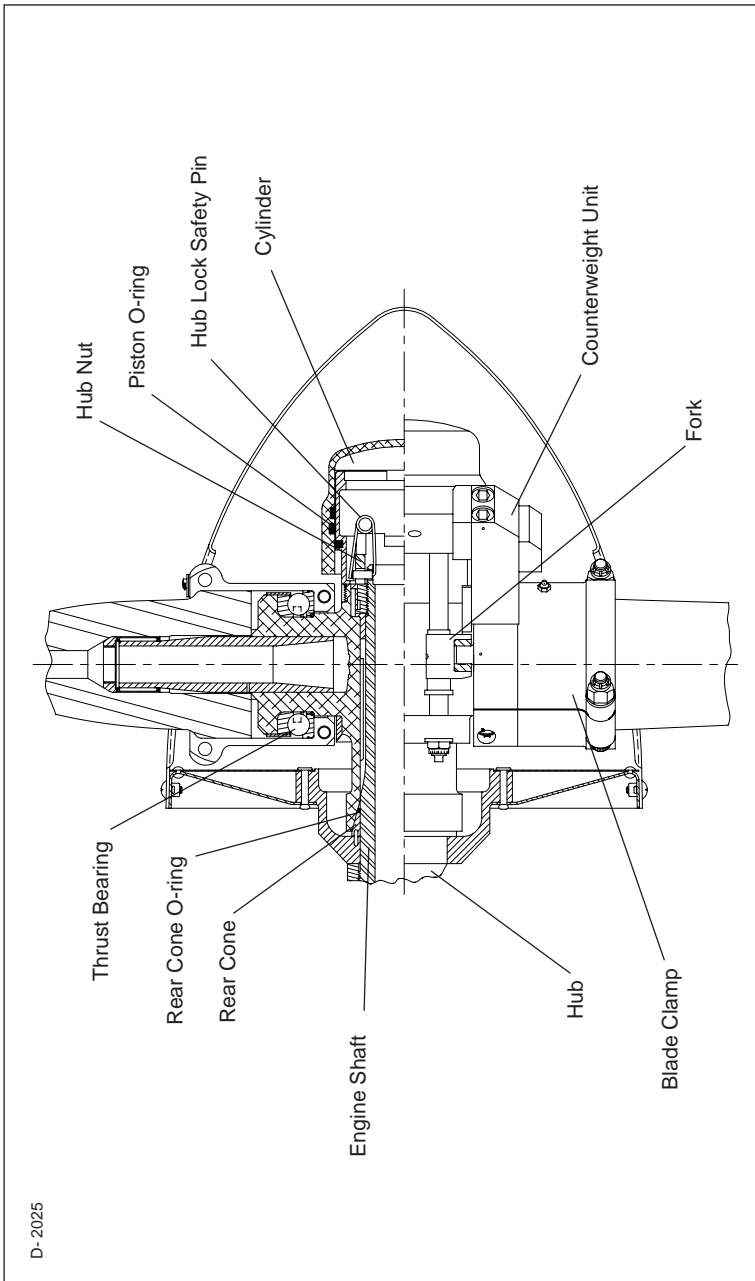

D-2025

**HC-A2(MV,V)20-1A Propeller Assembly
Figure 3-33**

- Q. Installing the 20 Spline Propeller Models HC-A2(MV,V)20-1A
Refer to Figure 3-33.

WARNING: MAKE SURE THE SLING IS RATED UP TO 800 POUNDS (363 KG) TO SUPPORT THE WEIGHT OF THE PROPELLER ASSEMBLY DURING INSTALLATION.

CAUTION 1: INSTRUCTIONS AND PROCEDURES IN THIS SECTION MAY INVOLVE PROPELLER CRITICAL PARTS. REFER TO THE INTRODUCTION CHAPTER OF THIS MANUAL FOR INFORMATION ABOUT PROPELLER CRITICAL PARTS. REFER TO THE ILLUSTRATED PARTS LIST CHAPTER OF THE APPLICABLE OVERHAUL MANUAL(S) FOR THE IDENTIFICATION OF SPECIFIC PROPELLER CRITICAL PARTS.

CAUTION 2: WHEN INSTALLING THE PROPELLER ON THE AIRCRAFT, DO NOT DAMAGE THE ICE PROTECTION SYSTEM COMPONENTS, IF APPLICABLE.

- (1) With a suitable crane hoist and sling, carefully move the propeller assembly to the aircraft engine mounting shaft.

NOTE: In most cases, the piston is not installed on the cylinder when the propeller is not installed on the engine.

CAUTION: THE PISTON MUST BE REMOVED BEFORE INSTALLING THE PROPELLER ON THE AIRCRAFT. IF THE PISTON HAS ALREADY BEEN REMOVED, PROCEED TO STEP 4.Q.(3).

- (2) Piston removal

(a) The piston ears, forks, and counterweights should have corresponding index numbers (1 and 2) impression-stamped or marked with a felt-tipped pen. If they are not marked, number them with a felt-tipped pen.

NOTE: This will insure that the components are reassembled in their original location.

- (b) Move the piston to low pitch
- (c) Loosen the set screw in each fork.
- (d) Rotate the forks away from the clamp linkscrews.
- (e) Remove the self-locking nut from the end of each guide rod.
- (f) Remove the washer from each guide rod.
- (g) Lift the piston from the cylinder.
- (h) Remove the sleeve from each bulkhead boss.
- (i) Remove the high stop spacer from each sleeve.

WARNING: CLEANING AGENT MEK IS FLAMMABLE AND TOXIC TO THE SKIN, EYES AND RESPIRATORY TRACT. SKIN AND EYE PROTECTION ARE REQUIRED. AVOID PROLONGED CONTACT. USE IN A WELL VENTILATED AREA.

- (3) Clean the propeller hub spline and engine spline surfaces with Quick Dry Stoddard Solvent or MEK.
- (4) Slide the rear spinner bulkhead onto the engine shaft.
- (5) Install the rear cone onto the bulkhead, matching the holes in the cone with the pins in the bulkhead (Figure 3-30). Push the cone against the bulkhead.
- (6) Install the rear cone O-ring (Table 3-1) over the shaft and against the cone.
- (7) Slide the propeller hub onto the engine shaft.
- (8) Tighten the hub nut until the rear bulkhead is snug, but do not torque the nut.

CAUTION: TO PREVENT DAMAGE TO THE BLADE AND BLADE PAINT, WRAP THE BLADE SHANKS IN SEVERAL LAYERS OF MASKING OR DUCT TAPE BEFORE INSTALLING THE SPINNER DOME. REMOVE THE TAPE AFTER THE SPINNER IS INSTALLED.

- (9) Carefully slide the spinner dome over the installed propeller.
- (10) To properly position the rear bulkhead, temporarily install the spinner dome using at least three screws.

- (11) Adjust the spinner to equalize the clearance between the blades and the blade cutouts in the dome.
- (12) Remove the spinner dome.
- (13) Torque the propeller shaft nut (Table 3-1) using tool BST-2910. Refer to Table 3-2 and Figure 3-4 to determine the proper torque value to which the torque wrench must be set.
- (14) Safety the hub nut using the hub lock safety pin (Table 3-1). Refer to Figure 3-31.
- (15) If the piston O-ring (Table 3-1) and the felt dust seal are not already installed in the piston, perform the following steps: Refer to Figure 3-32.
 - (a) Lubricate the piston O-ring and carefully install it in the inner groove provided for it in the piston.
 - (b) Cut the felt dust seal material to the necessary length.

NOTE: Cut the felt dust seal material on a 30 degree diagonal so there will be an overlap with a smooth, fuzz-free surface.
 - (c) Soak the felt dust seal material in aviation grade reciprocating engine oil until it is completely saturated.
 - (d) Squeeze the excess oil from the felt dust seal.
 - (e) Install the felt dust seal material in the outer groove provided for it in the piston.
 - (f) Install the rod O-ring (Table 3-1) in the groove at the end of the threaded portion of the pitch change rod.

CAUTION: TO MAINTAIN PROPER BLADE ANGLES, REINSTALL THE PISTON IN THE SAME POSITION AS WHEN IT WAS ORIGINALLY ASSEMBLED. INDEX NUMBERS ON THE PISTON AND THE GUIDE COLLAR ARE PROVIDED TO INSURE PROPER POSITIONING.

- (16) Locate and match up the index numbers (1 and 2) on the forks and piston ears with the corresponding index numbers on the counterweights.

NOTE: The index marks will be either impression-stamped or drawn with a felt-tipped pen.

- (17) Install the high stop spacers (Table 3-1) on each rod sleeve.

- (18) Slide the rod sleeves with high stop spacers into each spinner bulkhead boss.
- (19) Oil the entire surface of the cylinder.
- (20) Install the pitch change block on each clamp linkscrew.

CAUTION: POSITION THE THICK SIDE OF THE FORK
ON THE ENGINE SIDE OF THE PITCH
CHANGE BLOCK.

- (21) Slide a fork onto each pitch change block.
- (22) Slide the guide rods through the forks and rod sleeves until the piston rods protrude through the spinner bulkhead.
- (23) Install the washer and self-locking nut (Table 3-1) on the end of each of the guide rods.
NOTE: Align the forks with the pitch change blocks.
- (24) Torque the self-locking nut against the guide rod. Refer to Table 3-2.
- (25) Tighten the set screw in each fork until snug.
- (26) Safety the set screws.
- (27) If the propeller is equipped with an ice protection system that uses components supplied by Hartzell Propeller Inc., applicable instructions and technical information for the components supplied by Hartzell can be found in the following publications available on the Hartzell website at www.hartzellprop.com.

- (a) Manual 180 (30-61-80) - Propeller Ice Protection System Manual
- (b) Manual 181 (30-60-81) - Propeller Ice Protection Component Maintenance Manual
- (c) Manual 182 (61-12-82) - Propeller Electrical De-ice Boot Removal and Installation Manual
- (d) Manual 183 (61-12-83) - Propeller Anti-icing Boot Removal and Installation Manual

- (28) Propeller ice protection system components not supplied by Hartzell Propeller Inc. are controlled by the applicable TC or STC holder's Instructions for Continued Airworthiness (ICA).

I (29) Install the spinner dome as follows:

CAUTION 1: TO PREVENT DAMAGE TO THE BLADE AND BLADE PAINT, WRAP THE BLADE SHANKS IN SEVERAL LAYERS OF MASKING OR DUCT TAPE BEFORE INSTALLING THE SPINNER DOME. REMOVE THE TAPE AFTER THE SPINNER IS INSTALLED.

CAUTION 2: THE SPINNER DOME WILL WOBBLE IF NOT ALIGNED PROPERLY, AND MAY AFFECT THE BALANCE OF THE PROPELLER.

NOTE: The following instructions relate to Hartzell spinners only. In some cases, the airframe manufacturer produced the spinner assembly. In those cases, refer to the airframe manufacturer's manual for spinner installation instructions.

- (a) Carefully slide the spinner dome over the installed propeller.
- (b) Secure the spinner dome to the spinner bulkhead with the supplied screws and washers.

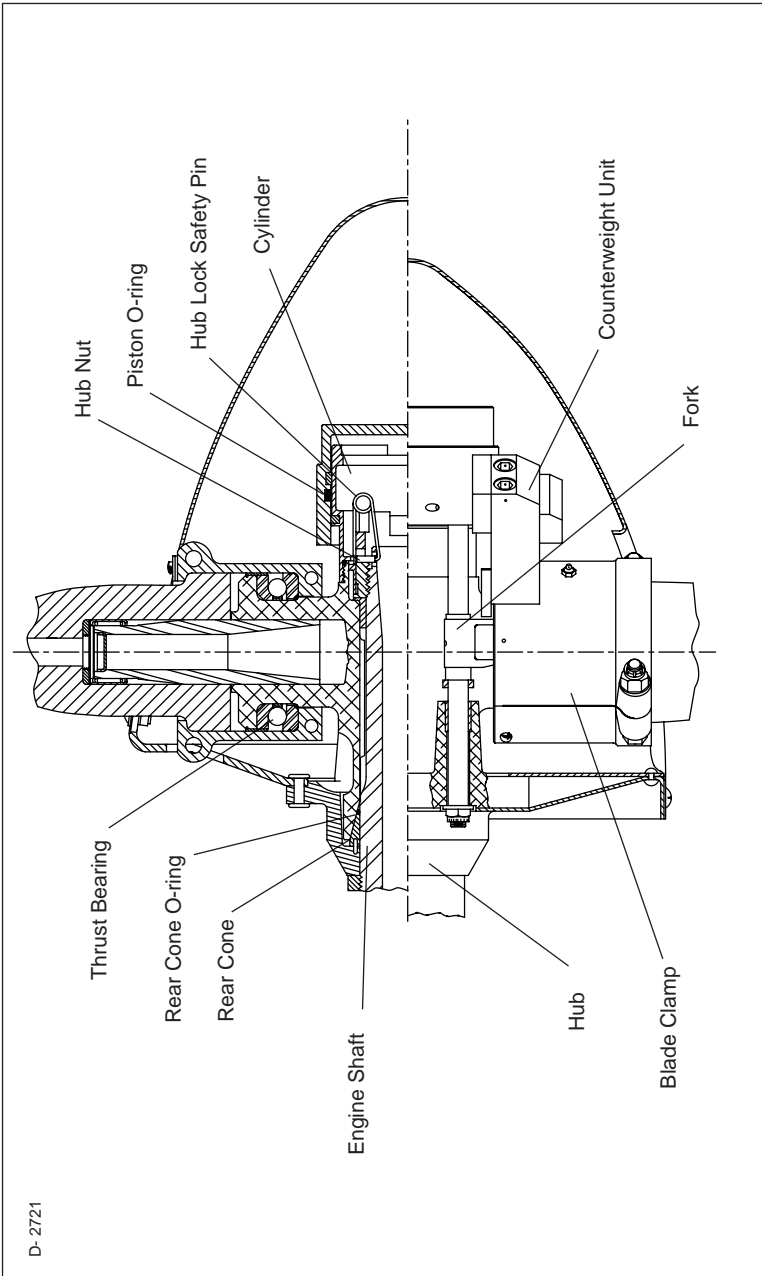

D-2721

HC-A3(MV,V)20-1() Propeller Assembly
Figure 3-34

R. Installing Splined Propeller Models HC-A3(MV,V)20-1()

Refer to Figure 3-34.

WARNING: MAKE SURE THE SLING IS RATED UP TO 800 POUNDS (363 KG) TO SUPPORT THE WEIGHT OF THE PROPELLER ASSEMBLY DURING INSTALLATION.

CAUTION 1: INSTRUCTIONS AND PROCEDURES IN THIS SECTION MAY INVOLVE PROPELLER CRITICAL PARTS. REFER TO THE INTRODUCTION CHAPTER OF THIS MANUAL FOR INFORMATION ABOUT PROPELLER CRITICAL PARTS. REFER TO THE ILLUSTRATED PARTS LIST CHAPTER OF THE APPLICABLE OVERHAUL MANUAL(S) FOR THE IDENTIFICATION OF SPECIFIC PROPELLER CRITICAL PARTS.

CAUTION 2: WHEN INSTALLING THE PROPELLER ON THE AIRCRAFT, DO NOT DAMAGE THE ICE PROTECTION SYSTEM COMPONENTS, IF APPLICABLE.

- (1) With a suitable crane hoist and sling, carefully move the propeller assembly to the aircraft engine mounting flange.

NOTE: In most cases, the piston is not installed on the cylinder when the propeller is not installed on the engine.

CAUTION: THE PISTON MUST BE REMOVED BEFORE INSTALLING THE PROPELLER ON THE AIRCRAFT. IF THE PISTON HAS ALREADY BEEN REMOVED, PROCEED TO STEP 4.R.(3).

- (2) Piston removal

- (a) The piston ears, forks, and counterweights should have corresponding index numbers (1, 2, and 3) impression-stamped or marked with a felt-tipped pen. If they are not marked, number them with a felt-tipped pen.

NOTE: This will insure that the components are reassembled in their original location.

- (b) Move the piston to low pitch
- (c) Loosen the set screw in each fork.
- (d) Rotate the forks away from the clamp linkscrews.
- (e) Remove the self-locking nut from the end of each guide rod.
- (f) Remove the washer from each guide rod.
- (g) Lift the piston from the cylinder.
- (h) Remove the sleeve from each bulkhead boss.
- (i) Remove the high stop spacer from each sleeve.

WARNING: CLEANING AGENT MEK IS FLAMMABLE AND TOXIC TO THE SKIN, EYES AND RESPIRATORY TRACT. SKIN AND EYE PROTECTION ARE REQUIRED. AVOID PROLONGED CONTACT. USE IN A WELL VENTILATED AREA.

- (3) Clean the propeller hub spline and engine spline surfaces with Quick Dry Stoddard Solvent or MEK.

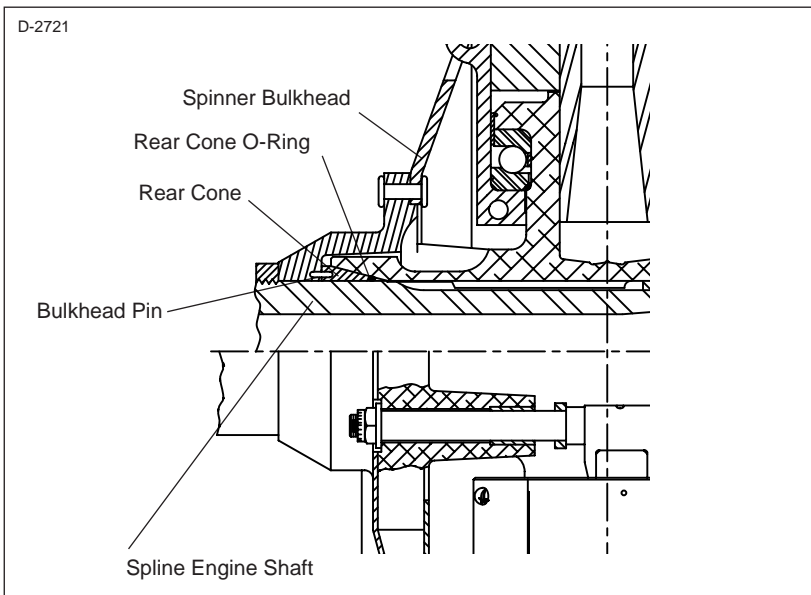

**Rear Hub Mounting Parts on HC-A3(MV,V)20-1 () Propeller
Figure 3-35**

- (4) If the rear cone is not installed, install it on the bulkhead, matching the holes in the cone with the pins in the bulkhead. Push the cone against the bulkhead.
- (5) Slide the rear spinner bulkhead onto the engine shaft.
- (6) Install the rear cone O-ring (Table 3-1) over the shaft and against the cone. Refer to Figure 3-35.
- (7) Slide the propeller hub onto the engine shaft and tighten the hub nut until the rear bulkhead is snug, but not tight. Do not torque the nut.

CAUTION: TO PREVENT DAMAGE TO THE BLADE AND BLADE PAINT, WRAP THE BLADE SHANKS IN SEVERAL LAYERS OF MASKING OR DUCT TAPE BEFORE INSTALLING THE SPINNER DOME. REMOVE THE TAPE AFTER THE SPINNER IS INSTALLED.

- (8) Carefully slide the spinner dome over the installed propeller.
- (9) To properly position the rear bulkhead, temporarily install the spinner dome with at least four screws.
- (10) Adjust the spinner to equalize the clearance between the blades and the blade cutouts in the dome.
- (11) Remove the spinner dome.
- (12) Using tool BST-2910, torque the propeller shaft nut (Table 3-1). Refer to Table 3-2 and Figure 3-4 to determine the proper torque value to which the torque wrench must be set.
- (13) Safety the hub nut using the hub lock safety pin (Table 3-1). Refer to Figure 3-31.
- (14) If the piston O-ring (Table 3-1) and the felt dust seal are not already installed in the piston, perform the following steps. Refer to Figure 3-32.
 - (a) Lubricate the piston O-ring and carefully install it in the inner groove provided for it in the piston.
 - (b) Cut the felt dust seal material to the necessary length.

NOTE: Cut the felt dust seal material on a 30 degree diagonal so there will be an overlap with a smooth, fuzz-free surface.

- (c) Soak the felt dust seal material in aviation grade reciprocating engine oil until it is completely saturated.
- (d) Squeeze the excess oil from the felt dust seal.
- (e) Install the felt dust seal material in the outer groove provided for it in the piston.
- (f) Install the rod O-ring (Table 3-1) in the groove at the end of the threaded portion of the pitch change rod.

CAUTION: TO MAINTAIN PROPER BLADE ANGLES, REINSTALL THE PISTON IN THE SAME POSITION AS WHEN IT WAS ORIGINALLY ASSEMBLED. INDEX NUMBERS ON THE PISTON AND THE GUIDE COLLAR ARE PROVIDED TO INSURE PROPER POSITIONING.

- (15) Locate and match up the index numbers (1, 2, and 3) on the forks and piston ears with the corresponding index numbers on the counterweights.

NOTE: The index marks will be either impression-stamped or drawn with a felt-tipped pen.

- (16) Install the high stop spacer(s) (Table 3-1) on each rod sleeve.
- (17) Slide the rod sleeves with high stop spacers into each spinner bulkhead boss.
- (18) Oil the entire surface of the cylinder.
- (19) Install the pitch change block on each clamp linkscrew.

CAUTION: POSITION THE THICK SIDE OF THE FORK ON THE ENGINE SIDE OF THE PITCH CHANGE BLOCK.

- (20) Slide a fork onto each pitch change block.
- (21) Install the piston:
 - (a) Engage the forks on the pitch change blocks.
 - (b) Slide the guide rods through the forks and rod sleeves until the piston rods protrude through the spinner bulkhead.

(22) Install the washer and self-locking nut (Table 3-1) on the end of each of the guide rods.

NOTE: Align the forks with the pitch change blocks.

(23) Torque the self-locking nut against the guide rod. Refer to Table 3-2.

(24) Tighten the set screw in each fork until snug.

(25) Safety the set screws with CM162 safety wire.

(26) Install the spinner dome as follows:

CAUTION 1: TO PREVENT DAMAGE TO THE BLADE AND BLADE PAINT, WRAP THE BLADE SHANKS IN SEVERAL LAYERS OF MASKING OR DUCT TAPE BEFORE INSTALLING THE SPINNER DOME. REMOVE THE TAPE AFTER THE SPINNER IS INSTALLED.

CAUTION 2: THE SPINNER DOME WILL WOBBLE IF NOT ALIGNED PROPERLY, AND MAY AFFECT THE BALANCE OF THE PROPELLER.

NOTE: The following instructions relate to Hartzell spinners only. In some cases, the airframe manufacturer produced the spinner assembly. In those cases, refer to the airframe manufacturer's manual for spinner installation instructions.

- (a) Carefully slide the spinner dome over the reinstalled propeller.
- (b) Secure the spinner dome to the spinner bulkhead with the supplied screws and washers.

(This page is intentionally blank.)

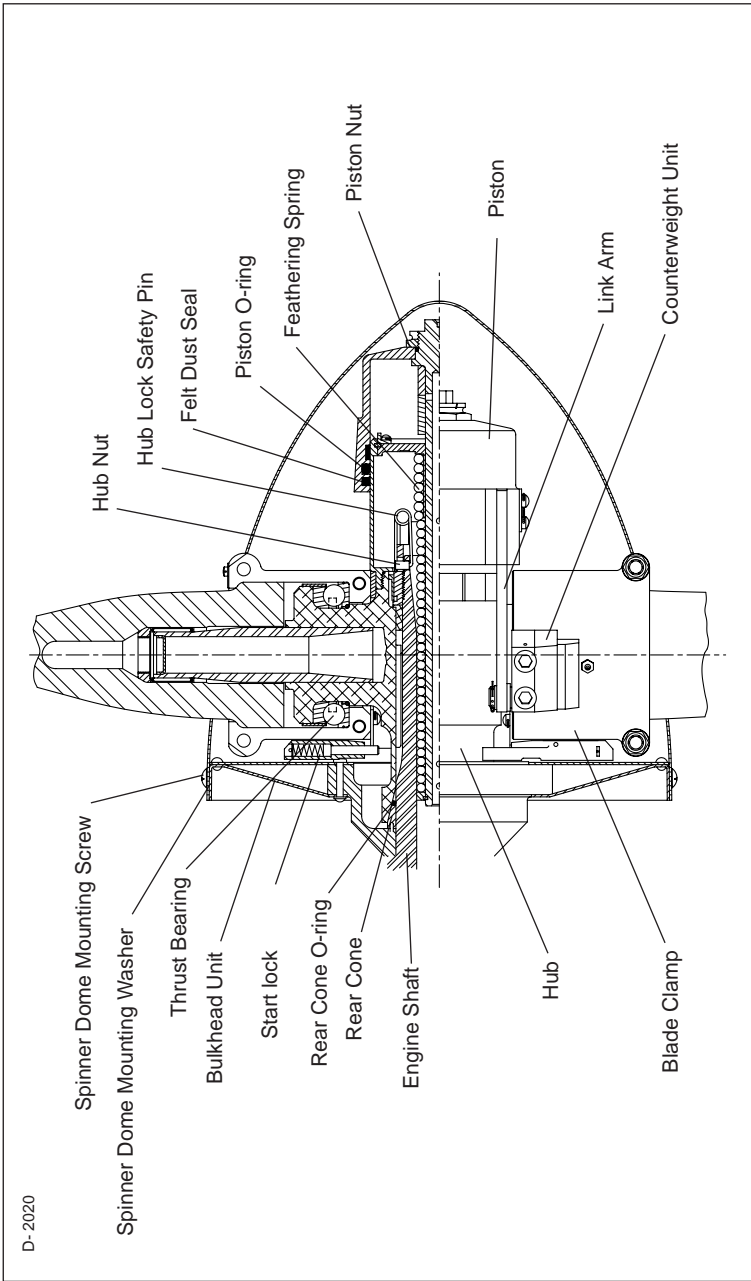

HC-A2(MV,V)20-2 Propeller Assembly
Figure 3-36

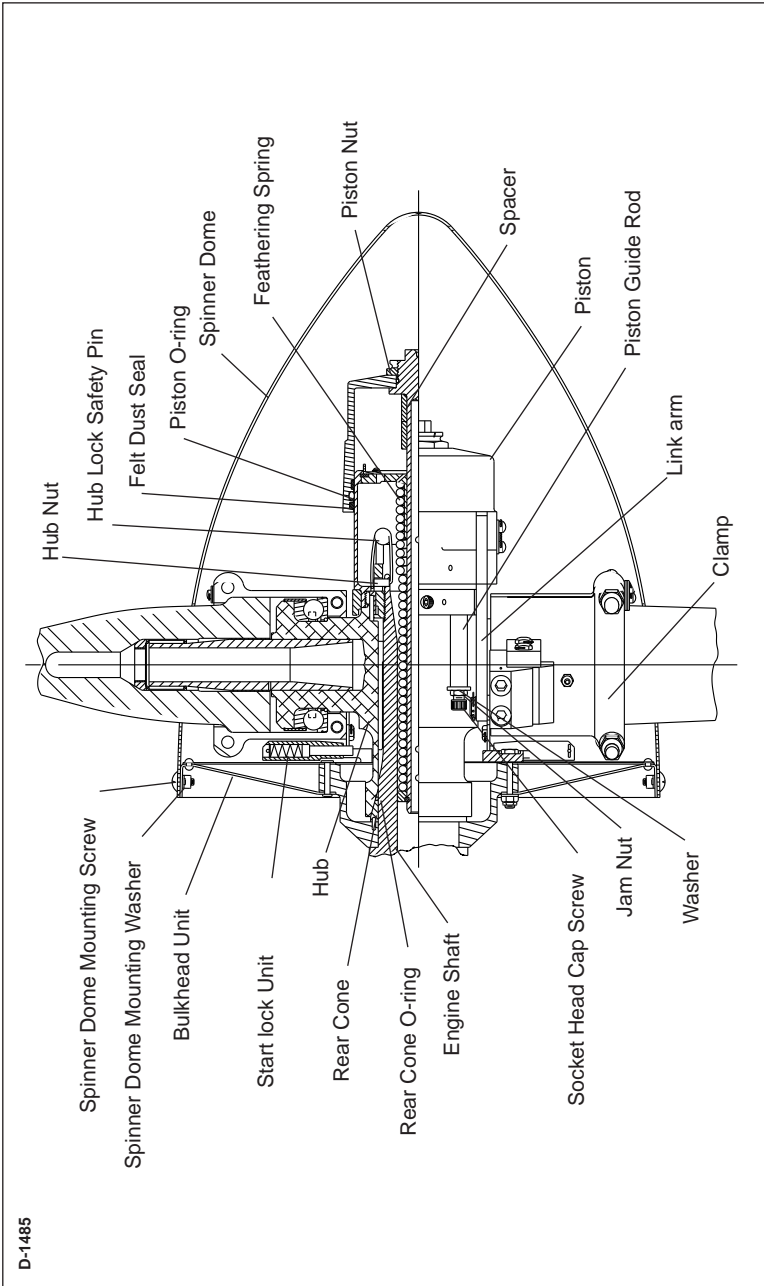

HC-A3(MV,V)20-2() Propeller Assembly
Figure 3-37

- S. Installing Splined Propeller Models HC-A2(MV,V)20-2 and HC-A3(MV,V)20-2 ()

Refer to Figures 3-36 AND 3-37.

WARNING: MAKE SURE THE SLING IS RATED UP TO 800 POUNDS (363 KG) TO SUPPORT THE WEIGHT OF THE PROPELLER ASSEMBLY DURING INSTALLATION.

- (1) With a suitable crane hoist and sling, carefully move the propeller assembly to the aircraft engine mounting flange in preparation for installation.

NOTE: If the propeller is equipped with an anti-ice or a de-ice system, follow the applicable manufacturer's instructions for installation of the anti-ice or de-ice system hardware.

CAUTION 1: INSTRUCTIONS AND PROCEDURES IN THIS SECTION MAY INVOLVE PROPELLER CRITICAL PARTS. REFER TO THE INTRODUCTION CHAPTER OF THIS MANUAL FOR INFORMATION ABOUT PROPELLER CRITICAL PARTS. REFER TO THE ILLUSTRATED PARTS LIST CHAPTER OF THE APPLICABLE OVERHAUL MANUAL(S) FOR THE IDENTIFICATION OF SPECIFIC PROPELLER CRITICAL PARTS.

CAUTION 2: THE PISTON MUST BE REMOVED BEFORE INSTALLING THE PROPELLER ON THE AIRCRAFT. IF THE PISTON HAS ALREADY BEEN REMOVED, PROCEED TO STEP 4.S.(3).

- (2) Piston Removal (Refer to Figures 3-28, 3-36, and 3-37.)
- (a) Remove the piston nut, if it was not previously removed to facilitate boxing and shipping of the propeller.
 - (b) Remove the safety wire (if installed) from the link pin units.
 - (c) Remove the safety screw from each link pin unit.
 - (d) Remove each link pin unit.

- (e) The piston ears and guide collar should have corresponding index numbers (1 and 2 on a 2-blade propeller; 1, 2, and 3 on a 3-blade propeller) impression-stamped or marked with a felt-tipped pen. If they are not marked, number them with a felt-tipped pen.

NOTE: This will make sure that the components are reassembled in their original location.

- (f) Slide the link arms out of the piston slots.
- (g) Remove the socket head cap screw (Table 3-1), jam nut, and washer from each piston guide rod.
- (h) Slide the piston off the cylinder.

CAUTION: THE FEATHERING SPRING ASSEMBLY MUST BE REMOVED BEFORE INSTALLING THE PROPELLER ON THE AIRCRAFT. IF THE FEATHERING SPRING ASSEMBLY HAS ALREADY BEEN REMOVED, PROCEED TO STEP 4.R.(4).

- (3) Feathering spring assembly removal:
Refer to Figure 3-38.

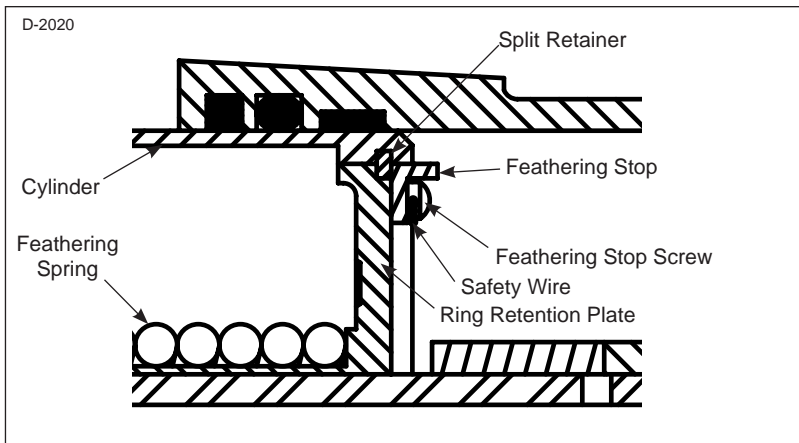

**Spring Assembly-to-Cylinder Attachment Details
Figure 3-38**

WARNING: DO NOT FORCE THE FEATHERING SPRING TO RELEASE THE SPLIT RINGS IN THE CYLINDER. FORCING THE FEATHERING SPRING MAY CAUSE THE RELEASE OF THE SPLIT RING RETAINERS IN THE SPRING ASSEMBLY, RESULTING IN THE EXPLOSIVE RELEASE OF THE FEATHERING SPRINGS.

- (a) Remove the safety wire (if installed) from the feathering stop screws.
- (b) Remove the two screws from each of the two feathering stops on the front spring retainer.
- (c) Remove the feathering stops.
- (d) Remove the front spring retainer split rings by first pushing the spring assembly into the cylinder about 0.25 inch (6.3 mm), allowing the split rings to fall out of the groove in the piston.
- (e) Remove the feathering spring assembly from the cylinder.

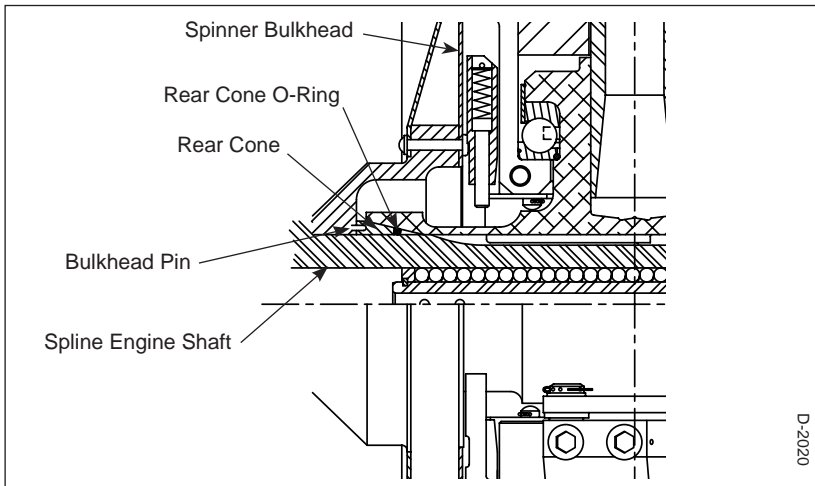

Rear Hub Mounting Parts
Figure 3-39

WARNING: CLEANING AGENT MEK IS FLAMMABLE AND TOXIC TO THE SKIN, EYES AND RESPIRATORY TRACT. SKIN AND EYE PROTECTION ARE REQUIRED. AVOID PROLONGED CONTACT. USE IN A WELL VENTILATED AREA.

- (4) Clean the propeller hub spline and engine spline surfaces with Quick Dry Stoddard Solvent or MEK.
- (5) Slide the spinner bulkhead onto the shaft.
- (6) Install the rear cone onto the bulkhead (Figure 3-39), matching the holes in the cone with the pins in the bulkhead.
- (7) Retract the start lock pins and hold them in place with a heavy wire inserted through the hole of each start lock housing.
- (8) Install the rear cone O-ring (Table 3-1) over the shaft. (Refer to Figure 3-39).
- (9) Slide the propeller hub onto the shaft and tighten the shaft nut until the rear bulkhead is snug, but not tight.

CAUTION: TO PREVENT DAMAGE TO THE BLADE AND BLADE PAINT, WRAP THE BLADE SHANKS IN SEVERAL LAYERS OF MASKING OR DUCT TAPE BEFORE INSTALLING THE SPINNER DOME. REMOVE THE TAPE AFTER THE SPINNER IS INSTALLED.

- (10) Carefully slide the spinner dome over the installed propeller.
- (11) To properly position the rear bulkhead, temporarily install the spinner dome with at least four screws.

NOTE: Make sure the start lock pins are parallel with the blade axis, but offset to one side.

- (12) Adjust the spinner to equalize the clearance between the blades and the blade cutouts in the dome.
- (13) Remove the spinner dome.
- (14) Using tool BST-2910, torque the propeller shaft nut (Table 3-1). Refer to Table 3-2 and Figure 3-4 to determine the proper torque value to which the torque wrench must be set.

(15) Safety the shaft nut to the engine shaft using a hub lock safety pin (Table 3-1). Refer to Figure 3-31.

NOTE: The hub lock safety pin is normally supplied in a separate package when the propeller is shipped new from the factory.

(16) Install the spring assembly.

- (a) Put the feathering spring assembly into the engine shaft, with the front spring retainer inside the cylinder.
- (b) Install the front split retainer between the cylinder and the front spring retainer, sliding the split retainer into the recess in the cylinder.
- (c) Pull the spring retainer tight against the front split retainer.
- (d) Install the feathering stop plate, which secures the split retainer, into place.
- (e) Install the stop screws and tighten them until they are snug.
- (f) Safety the stop screws with 0.032 inch (0.81 mm) minimum diameter stainless steel wire (two per safety).

(17) If the piston O-ring (Table 3-1) and the felt dust seal are not already installed in the piston, perform the following steps. Refer to Figure 3-32.

- (a) Lubricate the piston O-ring and carefully install it in the inner groove provided for it in the piston.
- (b) Cut the felt dust seal material to the necessary length.

NOTE: Cut the felt dust seal material on a 30 degree diagonal so there will be an overlap with a smooth, fuzz-free surface.

- (c) Soak the felt dust seal material in aviation grade reciprocating engine oil until it is completely saturated.
- (d) Squeeze the excess oil from the felt dust seal.
- (e) Install the felt dust seal material in the outer groove provided for it in the piston.
- (f) Install the rod O-ring (Table 3-1) in the groove at the end of the threaded portion of the pitch change rod.

(18) Install the rod O-ring (Table 3-1) in the groove at the end of the threaded portion of the pitch change rod.

CAUTION: TO MAINTAIN PROPER BLADE ANGLES, REINSTALL THE PISTON IN THE SAME POSITION AS WHEN IT WAS ORIGINALLY ASSEMBLED. INDEX NUMBERS ON THE PISTON AND THE GUIDE COLLAR ARE PROVIDED TO INSURE PROPER POSITIONING.

(19) Locate and match up the index numbers (1 and 2 on 2-blade propeller; 1, 2, and 3 on 3-blade propeller) on the piston ears with the corresponding index numbers on the guide collar. Refer to Figure 3-40.

NOTE: The index marks will be either impression-stamped or drawn with a felt-tipped pen.

(20) Oil the surface of the cylinder and install the piston.

(21) Slide the piston onto the cylinder and pass the guide rods through the collar bushing (Figure 3-40).

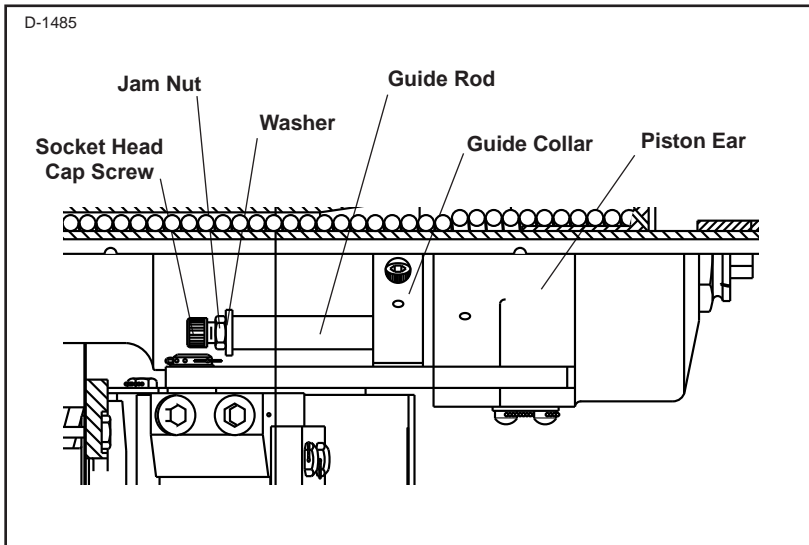

**Guide Rod Attachment Details
Figure 3-40**

- (22) Install the washer, jam nut, and socket head cap screw at the end of each guide rod (Figure 3-40).
- (23) Connect the link arms to the piston (Figure 3-28).
- (24) Install the link pin units.
- (25) Install the link pin safety screws (Figure 3-28).
- (26) Safety the two screws together with 0.032 inch (0.81 mm) minimum diameter stainless steel wire (Figure 3-28).
- (27) Carefully rotate the blades into feather position and fasten the piston to the pitch change rod with the piston nut (Table 3-1).
- (28) Torque the piston nut. Refer to Table 3-2.
- (29) Torque the jam nut against the guide rod. Refer to Table 3-2.
- (30) Remove the wires from the start lock brackets.
- (31) Position the propeller on the start locks.

CAUTION: DO NOT PUT THE BLADE PADDLE IN THE AREA OF THE DE-ICE BOOT WHEN APPLYING TORQUE TO A BLADE ASSEMBLY. PUT THE BLADE PADDLE IN THE THICKEST AREA OF THE BLADE, JUST OUTSIDE OF THE DE-ICE BOOT. USE ONE BLADE PADDLE PER BLADE.

- (32) Using the paddles, simultaneously rotate the blades toward low pitch until the start lock pins engage the start lock plate.

(33) Install the spinner dome as follows:

CAUTION 1: TO PREVENT DAMAGE TO THE BLADE AND BLADE PAINT, WRAP THE BLADE SHANKS IN SEVERAL LAYERS OF MASKING OR DUCT TAPE BEFORE INSTALLING THE SPINNER DOME. REMOVE THE TAPE AFTER THE SPINNER IS INSTALLED.

CAUTION 2: THE SPINNER DOME WILL WOBBLE IF NOT ALIGNED PROPERLY, AND MAY AFFECT THE BALANCE OF THE PROPELLER.

NOTE: The following instructions relate to Hartzell spinners only. In some cases, the airframe manufacturer produced the spinner assembly. In those cases, refer to the airframe manufacturer's manual for spinner installation instructions.

- (a) Carefully slide the spinner dome over the reinstalled propeller.
- (b) Secure the spinner dome to the spinner bulkhead with the supplied screws and washers.

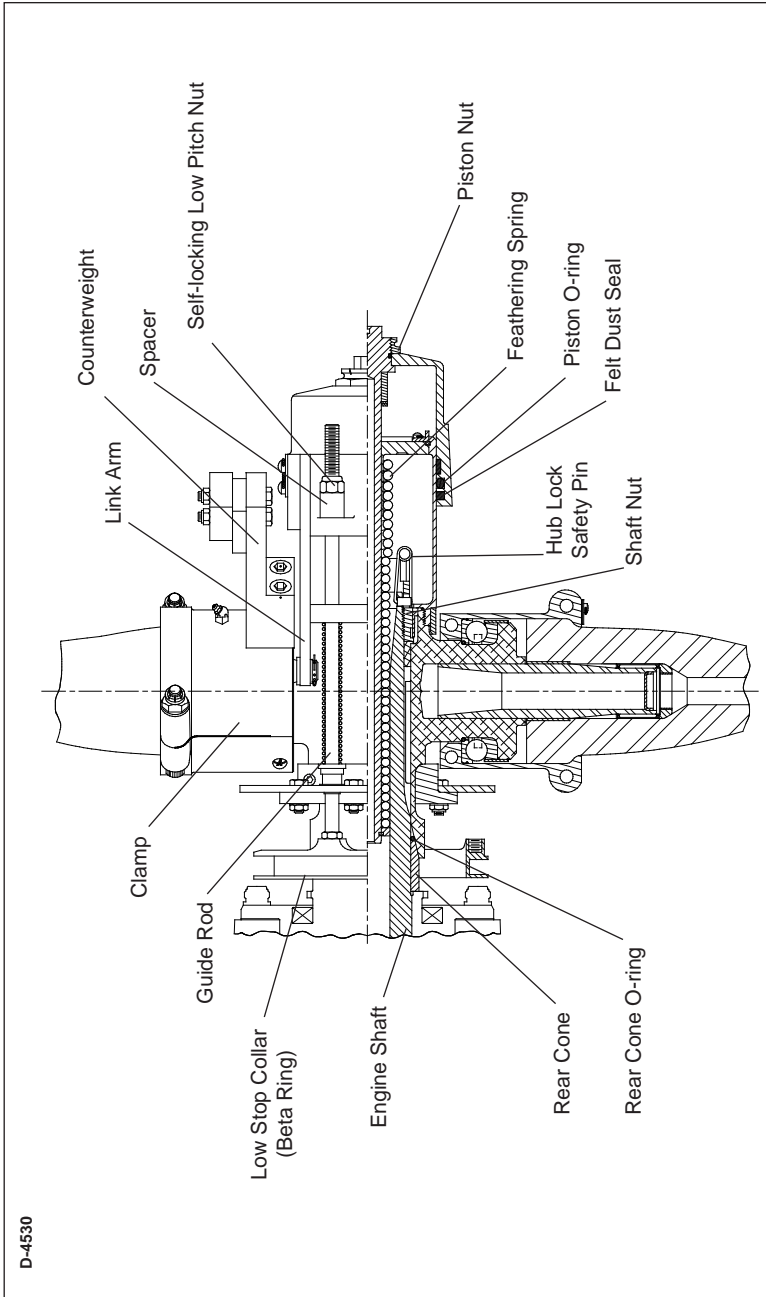

HC-A2(MV, V)20-3L Propeller Assembly
Figure 3-41

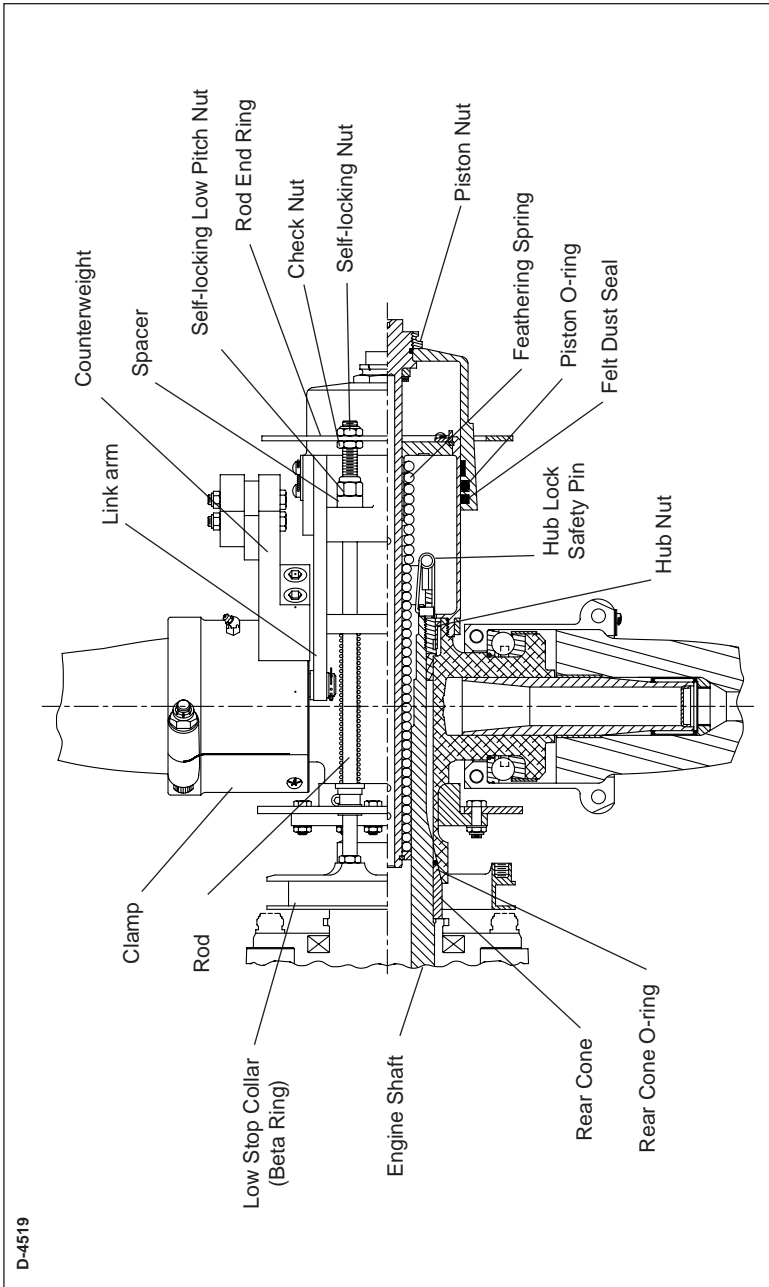

D-4519

HC-A3(MV,V)20-3L Propeller Assembly
Figure 3-42

- T. Installing the 20 Splined Propeller Models
HC-A2(MV,V)20-3L and HC-A3(MV,V)20-3L
Refer to Figures 3-41 and 3-42.

WARNING: MAKE SURE THE SLING IS RATED UP TO 800 POUNDS (363 KG) TO SUPPORT THE WEIGHT OF THE PROPELLER ASSEMBLY DURING INSTALLATION.

- (1) With a suitable crane hoist and sling, carefully move the propeller assembly to the aircraft engine shaft.

NOTE: If the propeller is equipped with an anti-ice or a de-ice system, follow the applicable manufacturer's instructions for installation of the anti-ice or de-ice system hardware.

CAUTION 1: INSTRUCTIONS AND PROCEDURES IN THIS SECTION MAY INVOLVE PROPELLER CRITICAL PARTS. REFER TO THE INTRODUCTION CHAPTER OF THIS MANUAL FOR INFORMATION ABOUT PROPELLER CRITICAL PARTS. REFER TO THE ILLUSTRATED PARTS LIST CHAPTER OF THE APPLICABLE OVERHAUL MANUAL(S) FOR THE IDENTIFICATION OF SPECIFIC PROPELLER CRITICAL PARTS.

CAUTION 2: THE PISTON MUST BE REMOVED BEFORE INSTALLING THE PROPELLER ON THE AIRCRAFT. IF THE PISTON HAS ALREADY BEEN REMOVED, PROCEED TO STEP 4.T.(3).

- (2) Piston Removal:

Refer to Figure 3-28.

- (a) Remove the piston nut.
- (b) Remove the safety wire (if installed) from the link pin units.
- (c) Remove the safety screw from each link pin unit.
- (d) Remove each link pin unit.

- (e) The piston ears and guide collar should have corresponding index numbers (1 and 2 for a two blade propeller, and 1, 2, and 3 for a three blade propeller) impression-stamped or marked with a felt-tipped pen. If they are not marked, number them with a felt-tipped pen.

NOTE: This will make sure that the components are reassembled in their original location.

- (f) Slide the link arms out of the piston slots.

CAUTION: THE POSITION OF THE LOW STOP COLLAR (BETA RING) IS ADJUSTED AT THE FACTORY AND MUST BE REINSTALLED IN THE SAME POSITION.

- (g) Measure and record the distance from the end of the rod to the top surface of the self-locking nut to insure that the hydraulic low pitch will be in the same blade angle when the piston and nut are reinstalled.

- (h) Remove the hardware from each rod.

- 1 Model HC-A2(MV,V)20-3L: Self-locking low pitch nut (Table 3-1) and spacer. Refer to Figure 3-41.
- 2 Model HC-A3(MV,V)20-3L: Self-locking nut, rod end ring, check nut, self-locking low pitch nut, and spacer (Table 3-1). Refer to Figure 3-42.

- (i) Slide the piston off the cylinder.

CAUTION: THE FEATHERING SPRING ASSEMBLY MUST BE REMOVED BEFORE INSTALLING THE PROPELLER ON THE AIRCRAFT. IF THE FEATHERING SPRING ASSEMBLY HAS ALREADY BEEN REMOVED, PROCEED TO STEP 4.S.(4)

- (3) Feathering spring assembly removal:
Refer to Figure 3-38.

WARNING: DO NOT FORCE THE FEATHERING SPRING TO RELEASE THE SPLIT RINGS IN THE CYLINDER. FORCING THE FEATHERING SPRING MAY CAUSE THE RELEASE OF THE SPLIT RING RETAINERS IN THE SPRING ASSEMBLY, RESULTING IN THE EXPLOSIVE RELEASE OF THE FEATHERING SPRINGS.

- (a) Remove the safety wire (if installed) from the feathering stop screws.
- (b) Remove the two screws from each of the two feathering stops on the front spring retainer.
- (c) Remove the feathering stops.
- (d) Remove the front spring retainer split rings by first pushing the feathering spring assembly into the cylinder about 0.25 inch (6.35 mm), allowing the split rings to fall out of the groove in the piston.
- (e) Remove the feathering spring assembly from the cylinder.

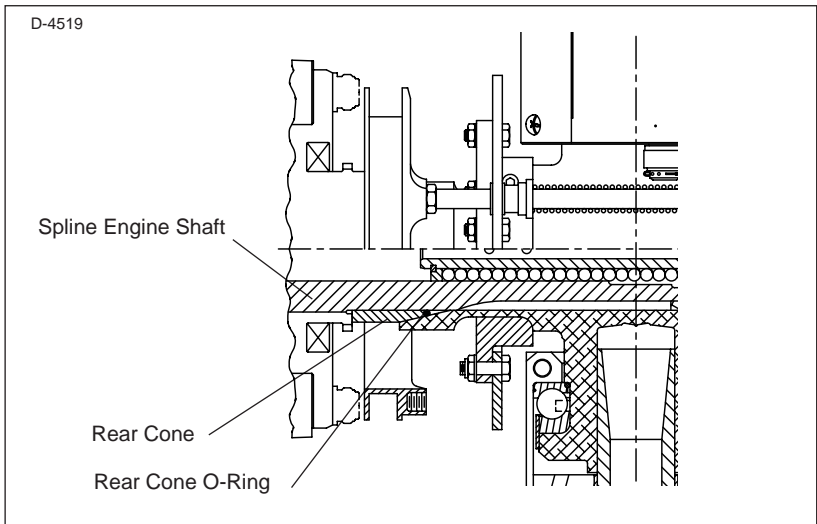

**Rear Hub Mounting Parts on HC-A(2,3)(MV,V)20-3L Propeller
Figure 3-43**

WARNING: CLEANING AGENT MEK IS FLAMMABLE AND TOXIC TO THE SKIN, EYES AND RESPIRATORY TRACT. SKIN AND EYE PROTECTION ARE REQUIRED. AVOID PROLONGED CONTACT. USE IN A WELL VENTILATED AREA.

- (4) Clean the propeller hub spline and engine spline surfaces with Quick Dry Stoddard Solvent or MEK.
- (5) Slide the rear cone onto the shaft.
- (6) Install the rear cone O-ring (Table 3-1) over the shaft and against the cone. (Refer to Figure 3-43).
- (7) Slide the propeller hub onto the engine and torque the propeller hub nut (Table 3-1) using tool BST-2910. Refer to Table 3-2 and Figure 3-4 to determine the proper torque value to which the torque wrench must be set.
- (8) Safety the hub nut to the engine shaft using a hub lock safety pin (Table 3-1). Refer to Figure 3-31.

NOTE: The hub lock safety pin is normally supplied in a separate package when the propeller is shipped new from the factory.

- (9) Install the spring assembly. Refer to Figures 3-41 and 3-42.
 - (a) Put the feathering spring assembly into the engine shaft, with the front spring retainer inside the cylinder.
 - (b) Install the front split retainer between the cylinder and the front spring retainer, sliding the split retainer into the recess in the cylinder.
 - (c) Pull the spring retainer tight against the front split retainer.
 - (d) Install the two feathering stops that secure the split retainer into place on the front of the spring retainer.
 - (e) Install the feathering stop retention screws and tighten them until they are snug.
 - (f) Safety the stop screws with 0.032 inch (0.81 mm) minimum diameter stainless steel wire (two per safety).

- (10) If the piston O-ring (Table 3-1) and the felt dust seal are not already installed in the piston, perform the following steps. Refer to Figure 3-32.
- (a) Lubricate the piston O-ring and carefully install it in the inner groove provided for it in the piston.
 - (b) Cut the felt dust seal material to the necessary length.
NOTE: Cut the felt dust seal material on a 30 degree diagonal so there will be an overlap with a smooth, fuzz-free surface.
 - (c) Soak the felt dust seal material in aviation grade reciprocating engine oil until it is completely saturated.
 - (d) Squeeze the excess oil from the felt dust seal.
 - (e) Install the felt dust seal material in the outer groove provided for it in the piston.
 - (f) Install the rod O-ring (Table 3-1) in the groove at the end of the threaded portion of the pitch change rod.
- (11) Install the rod O-ring (Table 3-1) in the groove at the end of the threaded portion of the pitch change rod.

CAUTION: TO MAINTAIN PROPER BLADE ANGLES, REINSTALL THE PISTON IN THE SAME POSITION AS WHEN IT WAS ORIGINALLY ASSEMBLED. INDEX NUMBERS ON THE PISTON AND THE GUIDE COLLAR ARE PROVIDED TO INSURE PROPER POSITIONING.

- (12) Locate and match up the index numbers (1 and 2 on a two blade propeller, and 1, 2, and 3 on a three blade propeller) on the piston ears with the corresponding index numbers on the guide collar.

NOTE: The index marks will be either impression-stamped or drawn with a felt-tipped pen.

- (13) Oil the entire surface of the cylinder and install the piston.
- (14) Align the piston with the beta rods, and slide the piston onto the beta rods and cylinder.
- (15) Connect the link arms to the piston (Figure 3-28).
- (16) Install the link pin units.
- (17) Install the link pin safety screws.

- (18) Safety the link pin screws together with 0.032 inch (0.81 mm) minimum diameter stainless steel wire (Figure 3-28).
- (19) Carefully rotate the blades into feather position and fasten the piston to the pitch change rod with the piston nut (Table 3-1).
- (20) Torque the piston nut in accordance with Table 3-2.
- (21) Install the spacer and self-locking low pitch nut (Table 3-1) on each beta rod.

WARNING: TO MAKE SURE OF PROPER LOW PITCH BLADE ANGLE, THE LOW PITCH NUTS MUST BE SET IN THE PROPER POSITION ON THE BETA RODS. OTHERWISE, POSSIBLE SERIOUS INJURY AND PROPELLER DAMAGE COULD RESULT.

- (22) If the propeller was received with the piston already removed, there should be an information tag attached to each beta return spring (Figure 3-44) indicating the proper position for the self-locking low-pitch nut on the end of the beta rod.

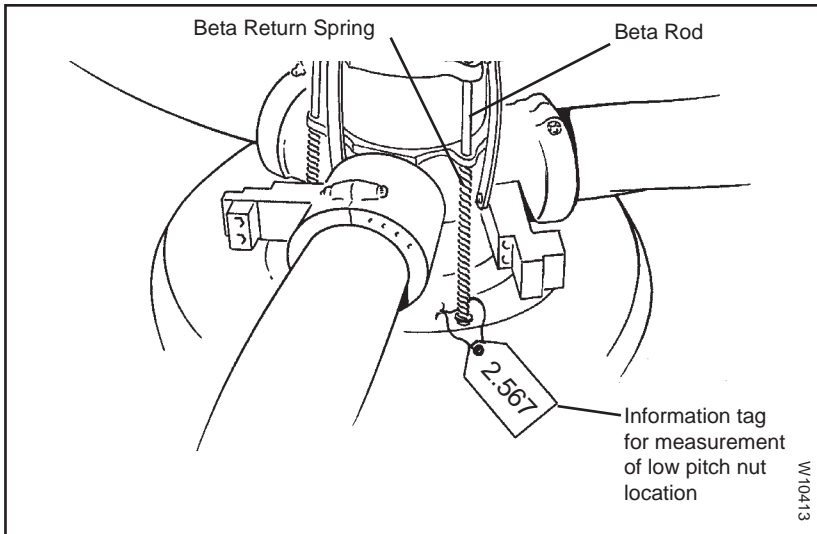

**Information Tag on Beta Return Spring
Figure 3-44**

- (a) Adjust the position of each self-locking low pitch nut so that the distance from the top surface of the self-locking nut to the end of the beta rod is as indicated on the information tag attached to the corresponding beta return spring on the beta rod. Refer to Figure 3-44.
- (23) If it was necessary to remove the piston for installation of the propeller, and no information tags were found on the beta return springs:
- (a) Refer to the distance measurements recorded in step 6.T.(2)(g) of this section to insure that the low pitch nuts will be set at the same position as before removal of the piston.
- (b) Refer to the Type Certificate Data sheet or Hartzell Propeller Application Guide to verify the proper low pitch blade angle.
- (24) On propeller model HC-A2MV20-3L only, install the check nut, rod end ring, and self-locking nut on each beta rod.
- (25) Torque the self-locking nut against the rod end ring. Refer to Table 3-2.
- (26) Install the carbon block into the beta linkage lever, in accordance with the airframe manufacturer's instructions.

CAUTION 1: FIT THE BLOCK IN THE BETA RING WITH A MINIMUM SIDE CLEARANCE OF 0.001 INCH (0.03 MM). REFER TO FIGURE 3-16.

CAUTION 2: MAXIMUM SIDE CLEARANCE PERMITTED IS 0.010 INCH (0.25 mm) IN ACCORDANCE WITH THE CARBON BLOCK ASSEMBLIES SECTION IN THE MAINTENANCE PRACTICES CHAPTER OF THIS MANUAL.

- (27) Install the carbon block assembly (Figure 3-17) into the beta ring.
- (28) Install, adjust and safety the beta linkage in accordance with the airframe manufacturer's instructions.

5. Post-Installation Checks
 - A. Refer to the airframe manufacturer's instructions for post-installation checks.
 - B. Perform a static RPM check as outlined in the Testing and Troubleshooting chapter of this manual.

6. Propeller Assembly Removal**A. Removing the F Flange Propeller Models****(B)HC-A2(MV,V)F-1()**

Refer to Figure 3-1.

NOTE: If the propeller is equipped with an anti-ice or a de-ice system, follow the manufacturer's instructions for removing the components necessary for propeller removal.

CAUTION 1: INSTRUCTIONS AND PROCEDURES IN THIS SECTION MAY INVOLVE PROPELLER CRITICAL PARTS. REFER TO THE INTRODUCTION CHAPTER OF THIS MANUAL FOR INFORMATION ABOUT PROPELLER CRITICAL PARTS. REFER TO THE ILLUSTRATED PARTS LIST CHAPTER OF THE APPLICABLE OVERHAUL MANUAL(S) FOR THE IDENTIFICATION OF SPECIFIC PROPELLER CRITICAL PARTS.

CAUTION 2: TO PREVENT DAMAGE TO THE BLADE AND BLADE PAINT, WRAP THE BLADE SHANKS IN SEVERAL LAYERS OF MASKING OR DUCT TAPE BEFORE REMOVING THE SPINNER DOME.

(1) Spinner dome removal

- (a) Remove the screws and washers that secure the spinner to the spinner bulkhead.
- (b) Remove the spinner dome.
- (c) Remove layers of masking or duct tape from each blade shank, if applicable.

WARNING 1: DURING ENGINE INSTALLATION OR REMOVAL, USING THE PROPELLER TO SUPPORT THE WEIGHT OF THE ENGINE IS NOT AUTHORIZED. UNAPPROVED INSTALLATION AND REMOVAL TECHNIQUES MAY CAUSE DAMAGE TO THE PROPELLER THAT MAY LEAD TO FAILURE AND RESULT IN AN AIRCRAFT ACCIDENT.

WARNING 2: DURING PROPELLER REMOVAL, AIRFRAME MANUFACTURER'S MANUALS AND PROCEDURES MUST BE FOLLOWED BECAUSE THEY MAY CONTAIN ISSUES VITAL TO AIRCRAFT SAFETY THAT ARE NOT CONTAINED IN THIS MANUAL OR IN THE HARTZELL PROPELLER OVERHAUL MANUALS.

(2) Remove the safety wire on the propeller mounting bolts.

WARNING: MAKE SURE THE SLING IS RATED UP TO 800 POUNDS (363 KG.) TO SUPPORT THE WEIGHT OF THE PROPELLER ASSEMBLY DURING REMOVAL.

(3) Support the propeller assembly with a sling.

NOTE 1: To allow rotation of the propeller for ease of bolt removal, supporting the propeller with a sling may be delayed until all but two mounting bolts and washers have been removed.

NOTE 2: If the propeller will be reinstalled, and it has been dynamically balanced, make an identifying mark (with a felt-tipped pen only) on the propeller hub and a matching mark on the engine flange to ensure proper positioning of the propeller during reinstallation. This will prevent dynamic imbalance.

CAUTION: DISCARD THE PROPELLER MOUNTING BOLTS AND WASHERS IF THEY ARE DAMAGED OR CORRODED, OR IF THE PROPELLER IS REMOVED FOR OVERHAUL.

(4) Unthread the propeller mounting bolts from the engine flange.

NOTE: For propeller removals between overhaul intervals, mounting bolts and washers may be reused if they are not damaged or corroded.

CAUTION: USE ADEQUATE PRECAUTIONS TO PROTECT THE PROPELLER ASSEMBLY FROM DAMAGE WHEN IT IS REMOVED FROM THE AIRCRAFT ENGINE AND WHEN IT IS STORED.

- (5) Using the support sling, lift the propeller from the mounting flange.
- (6) Remove and discard the engine shaft O-ring.
- (7) Remove the spinner bulkhead.
- (8) Put the propeller and associated parts on a suitable cart for transportation.

- B. Removing the K and L Flange Propeller Models HC-A2(MV,V)(K,L)-1() and HC-A2(MV,V)L-6F
Refer to Figure 3-1.

NOTE: If the propeller is equipped with an anti-ice or a de-ice system, follow the manufacturer's instructions for removing the components necessary for propeller removal.

CAUTION 1: INSTRUCTIONS AND PROCEDURES IN THIS SECTION MAY INVOLVE PROPELLER CRITICAL PARTS. REFER TO THE INTRODUCTION CHAPTER OF THIS MANUAL FOR INFORMATION ABOUT PROPELLER CRITICAL PARTS. REFER TO THE ILLUSTRATED PARTS LIST CHAPTER OF THE APPLICABLE OVERHAUL MANUAL(S) FOR THE IDENTIFICATION OF SPECIFIC PROPELLER CRITICAL PARTS.

CAUTION 2: TO PREVENT DAMAGE TO THE BLADE AND BLADE PAINT, WRAP THE BLADE SHANKS IN SEVERAL LAYERS OF MASKING OR DUCT TAPE BEFORE REMOVING THE SPINNER DOME.

- (1) Spinner dome removal
 - (a) Remove the screws and washers that secure the spinner to the spinner adapter ring.
 - (b) Remove the spinner dome.
 - (c) Remove layers of masking or duct tape from each blade shank, if applicable.

WARNING 1: DURING ENGINE INSTALLATION OR REMOVAL, USING THE PROPELLER TO SUPPORT THE WEIGHT OF THE ENGINE IS NOT AUTHORIZED. UNAPPROVED INSTALLATION AND REMOVAL TECHNIQUES MAY CAUSE DAMAGE TO THE PROPELLER THAT MAY LEAD TO FAILURE AND RESULT IN AN AIRCRAFT ACCIDENT.

WARNING 2: DURING PROPELLER REMOVAL, AIRFRAME MANUFACTURER'S MANUALS AND PROCEDURES MUST BE FOLLOWED BECAUSE THEY MAY CONTAIN ISSUES VITAL TO AIRCRAFT SAFETY THAT ARE NOT CONTAINED IN THIS MANUAL OR IN THE HARTZELL PROPELLER OVERHAUL MANUALS.

(2) Remove the safety wire on the propeller mounting bolts.

WARNING: MAKE SURE THE SLING IS RATED UP TO 800 POUNDS (363 KG.) TO SUPPORT THE WEIGHT OF THE PROPELLER ASSEMBLY DURING REMOVAL.

(3) Support the propeller assembly with a sling.

NOTE 1: To allow rotation of the propeller for ease of bolt removal, supporting the propeller with a sling may be delayed until all but two mounting bolts and washers have been removed.

NOTE 2: If the propeller will be reinstalled, and it has been dynamically balanced, make an identifying mark (with a felt-tipped pen only) on the propeller hub and a matching mark on the engine flange to ensure proper positioning of the propeller during reinstallation. This will prevent dynamic imbalance.

CAUTION: DISCARD THE PROPELLER MOUNTING BOLTS AND WASHERS IF THEY ARE DAMAGED OR CORRODED, OR IF THE PROPELLER IS REMOVED FOR OVERHAUL.

- (4) Remove the propeller mounting bolts from the engine flange.
- (5) Remove two propeller mounting bolts and washers.

NOTE 1: Four of the propeller mounting bolts and washers cannot be removed from the propeller hub due to interference with other propeller parts.

NOTE 2: For propeller removals between overhaul intervals, mounting bolts and washers may be reused if they are not damaged or corroded.

CAUTION: USE ADEQUATE PRECAUTIONS TO PROTECT THE PROPELLER ASSEMBLY FROM DAMAGE WHEN IT IS REMOVED FROM THE AIRCRAFT ENGINE AND WHEN IT IS STORED.

- (6) Using the support sling, lift the propeller from the mounting flange.
- (7) Remove and discard the shaft O-ring.
- (8) Remove the shim.
- (9) If the spinner was manufactured by Hartzell Propeller:
 - (a) Do not remove the spinner adapter ring.
 - (b) Visually inspect the spinner adapter ring for cracks.
 - (c) If cracks are found in the spinner adapter ring, remove it from the engine starter ring gear and replace it.
- (10) Put the propeller on a suitable cart for transportation.

- C. Removing the F Flange Propeller Models HC-A2(MV,V)F-2()
Refer to Figure 3-7.

NOTE: If the propeller is equipped with an anti-ice or a de-ice system, follow the manufacturer's instructions for removing the components necessary for propeller removal.

CAUTION 1: INSTRUCTIONS AND PROCEDURES IN THIS SECTION MAY INVOLVE PROPELLER CRITICAL PARTS. REFER TO THE INTRODUCTION CHAPTER OF THIS MANUAL FOR INFORMATION ABOUT PROPELLER CRITICAL PARTS. REFER TO THE ILLUSTRATED PARTS LIST CHAPTER OF THE APPLICABLE OVERHAUL MANUAL(S) FOR THE IDENTIFICATION OF SPECIFIC PROPELLER CRITICAL PARTS.

CAUTION 2: TO PREVENT DAMAGE TO THE BLADE AND BLADE PAINT, WRAP THE BLADE SHANKS IN SEVERAL LAYERS OF MASKING OR DUCT TAPE BEFORE REMOVING THE SPINNER DOME.

- (1) Spinner dome removal
- (a) Remove the screws and washers that secure the spinner to the spinner bulkhead.
 - (b) Remove the spinner dome.
 - (c) Remove layers of masking or duct tape from each blade shank, if applicable.

WARNING 1: DURING ENGINE INSTALLATION OR REMOVAL, USING THE PROPELLER TO SUPPORT THE WEIGHT OF THE ENGINE IS NOT AUTHORIZED. UNAPPROVED INSTALLATION AND REMOVAL TECHNIQUES MAY CAUSE DAMAGE TO THE PROPELLER THAT MAY LEAD TO FAILURE AND RESULT IN AN AIRCRAFT ACCIDENT.

WARNING 2: DURING PROPELLER REMOVAL, AIRFRAME MANUFACTURER'S MANUALS AND PROCEDURES MUST BE FOLLOWED BECAUSE THEY MAY CONTAIN ISSUES VITAL TO AIRCRAFT SAFETY THAT ARE NOT CONTAINED IN THIS MANUAL OR IN THE HARTZELL PROPELLER OVERHAUL MANUALS.

WARNING 3: USE CAUTION DURING PROPELLER REMOVAL WHEN THE START LOCKS ARE ENGAGED. IF THE BLADES ARE RELEASED SUDDENLY, THE EXTREME FORCE CAN CAUSE SERIOUS INJURY AND DAMAGE TO THE PROPELLER.

(2) Routine propeller engine shutdown will engage the start lock units, preventing the propeller from feathering. To allow access to the of the spinner mounting bolts, the start locks should remain engaged during the removal of the propeller.

(3) Remove the safety wire on the propeller mounting bolts.

WARNING: MAKE SURE THE SLING IS RATED UP TO 800 POUNDS (363 KG.) TO SUPPORT THE WEIGHT OF THE PROPELLER ASSEMBLY DURING REMOVAL.

(4) Support the propeller assembly with a sling.

NOTE 1: To allow rotation of the propeller for ease of bolt removal, supporting the propeller with a sling may be delayed until all but two mounting bolts and washers have been removed.

NOTE 2: If the propeller will be reinstalled, and it has been dynamically balanced, make an identifying mark (with a felt-tipped pen only) on the propeller hub and a matching mark on the engine flange to ensure proper positioning of the propeller during reinstallation. This will prevent dynamic imbalance.

CAUTION: DISCARD THE PROPELLER MOUNTING BOLTS AND WASHERS IF THEY ARE DAMAGED OR CORRODED, OR IF THE PROPELLER IS REMOVED FOR OVERHAUL.

(5) Remove the propeller mounting bolts and washers.

NOTE: For propeller removals between overhaul intervals, mounting bolts and washers may be reused if they are not damaged or corroded.

CAUTION: USE ADEQUATE PRECAUTIONS TO PROTECT THE PROPELLER ASSEMBLY FROM DAMAGE WHEN IT IS REMOVED FROM THE AIRCRAFT ENGINE AND WHEN IT IS STORED.

(6) Using the support sling, lift the propeller from the mounting flange.

(7) Remove and discard the shaft O-ring.

(8) Put the propeller, with spinner bulkhead and start locks attached, on a suitable cart for transportation.

- D. Removing the K and L Flange Propeller Models
HC-A2(MV,V)(K,L)-2()
Refer to Figure 3-7.

NOTE: If the propeller is equipped with an anti-ice or a de-ice system, follow the manufacturer's instructions for removing the components necessary for propeller removal.

CAUTION 1: INSTRUCTIONS AND PROCEDURES IN THIS SECTION MAY INVOLVE PROPELLER CRITICAL PARTS. REFER TO THE INTRODUCTION CHAPTER OF THIS MANUAL FOR INFORMATION ABOUT PROPELLER CRITICAL PARTS. REFER TO THE ILLUSTRATED PARTS LIST CHAPTER OF THE APPLICABLE OVERHAUL MANUAL(S) FOR THE IDENTIFICATION OF SPECIFIC PROPELLER CRITICAL PARTS.

CAUTION 2: TO PREVENT DAMAGE TO THE BLADE AND BLADE PAINT, WRAP THE BLADE SHANKS IN SEVERAL LAYERS OF MASKING OR DUCT TAPE BEFORE REMOVING THE SPINNER DOME.

- (1) Spinner dome removal
- (a) Remove the screws and washers that secure the spinner to the spinner adapter ring.
 - (b) Remove the spinner dome.
 - (c) Remove layers of masking or duct tape from each blade shank, if applicable.

WARNING 1: DURING ENGINE INSTALLATION OR REMOVAL, USING THE PROPELLER TO SUPPORT THE WEIGHT OF THE ENGINE IS NOT AUTHORIZED. UNAPPROVED INSTALLATION AND REMOVAL TECHNIQUES MAY CAUSE DAMAGE TO THE PROPELLER THAT MAY LEAD TO FAILURE AND RESULT IN AN AIRCRAFT ACCIDENT.

WARNING 2: DURING PROPELLER REMOVAL, AIRFRAME MANUFACTURER'S MANUALS AND PROCEDURES MUST BE FOLLOWED BECAUSE THEY MAY CONTAIN ISSUES VITAL TO AIRCRAFT SAFETY THAT ARE NOT CONTAINED IN THIS MANUAL OR IN THE HARTZELL PROPELLER OVERHAUL MANUALS.

WARNING 3: FOR SAFETY REASONS, THE PROPELLER MUST BE PUT IN THE FEATHER POSITION BEFORE IT IS REMOVED FROM THE AIRCRAFT.

- (2) Routine propeller engine shutdown will engage the start lock units, preventing the propeller from feathering. For purposes of propeller removal, the propeller should be put in feather position during engine shutdown. If this was not accomplished, then the propeller may be feathered as follows:

CAUTION: DO NOT PUT THE BLADE PADDLE IN THE AREA OF THE DE-ICE BOOT WHEN APPLYING TORQUE TO A BLADE ASSEMBLY. PUT THE BLADE PADDLE IN THE THICKEST AREA OF THE BLADE, JUST OUTBOARD OF THE DE-ICE BOOT. USE ONE BLADE PADDLE PER BLADE.

- (a) Rotate the blades simultaneously to a slightly lower pitch to disengage the start lock plates from the start lock units.
- (b) Retract the start lock pins and hold them in place with a heavy wire inserted through the hole of each start lock housing.
- (c) Slowly and carefully allow the blades to rotate to high/feather pitch.
- (3) Remove the safety wire on the propeller mounting bolts.

WARNING: MAKE SURE THE SLING IS RATED UP TO 800 POUNDS (363 KG.) TO SUPPORT THE WEIGHT OF THE PROPELLER ASSEMBLY DURING REMOVAL.

(4) Support the propeller assembly with a sling.

NOTE 1: To allow rotation of the propeller for ease of bolt removal, supporting the propeller with a sling may be delayed until all but two mounting bolts and washers have been removed.

NOTE 2: If the propeller will be reinstalled, and it has been dynamically balanced, make an identifying mark (with a felt-tipped pen only) on the propeller hub and a matching mark on the engine flange to ensure proper positioning of the propeller during reinstallation. This will prevent dynamic imbalance.

(5) Record the position of each start lock in relation to its matching blade.

(6) Remove the start lock brackets to access the mounting bolts.

NOTE: It is not necessary to remove the wire that is holding the stop pin in place.

CAUTION: DISCARD THE PROPELLER MOUNTING BOLTS AND WASHERS IF THEY ARE DAMAGED OR CORRODED, OR IF THE PROPELLER IS REMOVED FOR OVERHAUL.

(7) Remove the propeller mounting bolts from the engine flange.

(8) Remove four propeller mounting bolts and washers.

NOTE 1: Two of the propeller mounting bolts and washers cannot be removed from the propeller hub due to interference with other propeller parts.

NOTE 2: For propeller removals between overhaul intervals, mounting bolts and washers may be reused if they are not damaged or corroded.

CAUTION: USE ADEQUATE PRECAUTIONS TO PROTECT THE PROPELLER ASSEMBLY FROM DAMAGE WHEN IT IS REMOVED FROM THE AIRCRAFT ENGINE AND WHEN IT IS STORED.

- (9) Remove and discard the shaft O-ring.
- (10) Remove the shim.
- (11) Using the support sling, lift the propeller from the mounting flange.
- (12) If the spinner was manufactured by Hartzell Propeller:
 - (a) Do not remove the spinner adapter ring.
 - (b) Visually inspect the spinner adapter ring for cracks.
 - (c) If cracks are found in the spinner adapter ring, remove it from the engine starter ring gear and replace it.
- (13) Put the propeller on a suitable cart for transportation.

- E. Removing the F Flange Propeller Models (E,P)HC-A3(MV,V)F-2() except those using a spacer as specified in paragraph 6.F
Refer to Figure 3-10.

NOTE: If the propeller is equipped with an anti-ice or a de-ice system, follow the manufacturer's instructions for removing the components necessary for propeller removal.

CAUTION 1: INSTRUCTIONS AND PROCEDURES IN THIS SECTION MAY INVOLVE PROPELLER CRITICAL PARTS. REFER TO THE INTRODUCTION CHAPTER OF THIS MANUAL FOR INFORMATION ABOUT PROPELLER CRITICAL PARTS. REFER TO THE ILLUSTRATED PARTS LIST CHAPTER OF THE APPLICABLE OVERHAUL MANUAL(S) FOR THE IDENTIFICATION OF SPECIFIC PROPELLER CRITICAL PARTS.

CAUTION 2: TO PREVENT DAMAGE TO THE BLADE AND BLADE PAINT, WRAP THE BLADE SHANKS IN SEVERAL LAYERS OF MASKING OR DUCT TAPE BEFORE REMOVING THE SPINNER DOME.

- (1) Spinner dome removal
- (a) Remove the screws and washers that secure the spinner dome to the spinner bulkhead.
 - (b) Remove the spinner dome.
 - (c) Remove layers of masking or duct tape from each blade shank, if applicable.

WARNING 1: DURING ENGINE INSTALLATION OR REMOVAL, USING THE PROPELLER TO SUPPORT THE WEIGHT OF THE ENGINE IS NOT AUTHORIZED. UNAPPROVED INSTALLATION AND REMOVAL TECHNIQUES MAY CAUSE DAMAGE TO THE PROPELLER THAT MAY LEAD TO FAILURE AND RESULT IN AN AIRCRAFT ACCIDENT.

WARNING 2: DURING PROPELLER REMOVAL, AIRFRAME MANUFACTURER'S MANUALS AND PROCEDURES MUST BE FOLLOWED BECAUSE THEY MAY CONTAIN ISSUES VITAL TO AIRCRAFT SAFETY THAT ARE NOT CONTAINED IN THIS MANUAL OR IN THE HARTZELL PROPELLER OVERHAUL MANUALS.

WARNING 3: USE CAUTION DURING PROPELLER REMOVAL WHEN THE START LOCKS ARE ENGAGED. IF THE BLADES ARE RELEASED SUDDENLY, THE EXTREME FORCE CAN CAUSE SERIOUS INJURY AND DAMAGE TO THE PROPELLER.

- (2) Routine propeller engine shutdown will engage the start lock units, preventing the propeller from feathering. To allow access to the of the spinner mounting bolts, the start locks should remain engaged during the removal of the propeller.

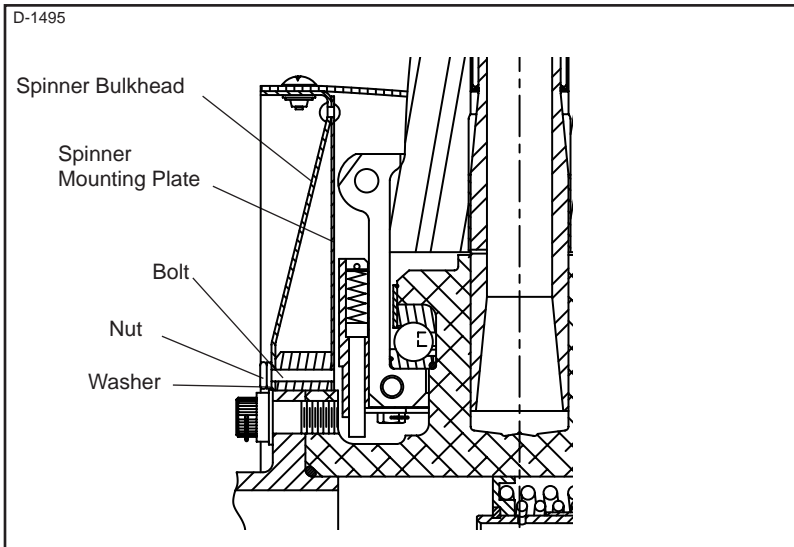

Spinner Bulkhead Removal
Figure 3-45

WARNING: MAKE SURE THE SLING IS RATED UP TO 800 POUNDS (363 KG.) TO SUPPORT THE WEIGHT OF THE PROPELLER ASSEMBLY DURING REMOVAL.

(3) Support the propeller assembly with a sling.

NOTE 1: To allow rotation of the propeller for ease of bolt removal, supporting the propeller with a sling may be delayed until all but two mounting bolts and washers have been removed.

NOTE 2: If the propeller will be reinstalled, and it has been dynamically balanced, make an identifying mark (with a felt-tipped pen only) on the propeller hub and a matching mark on the engine flange to ensure proper positioning of the propeller during reinstallation. This will prevent dynamic imbalance.

CAUTION: DISCARD THE PROPELLER MOUNTING BOLTS AND WASHERS IF THEY ARE DAMAGED OR CORRODED, OR IF THE PROPELLER IS REMOVED FOR OVERHAUL.

(4) Remove the propeller mounting bolts and washers.

NOTE: For propeller removals between overhaul intervals, mounting bolts and washers may be reused if they are not damaged or corroded.

CAUTION: USE ADEQUATE PRECAUTIONS TO PROTECT THE PROPELLER ASSEMBLY FROM DAMAGE WHEN IT IS REMOVED FROM THE AIRCRAFT ENGINE AND WHEN IT IS STORED.

(5) Using the support sling, lift the propeller from the mounting flange.

(6) Remove and discard the shaft O-ring.

(7) Put the propeller, with spinner bulkhead and start locks attached, on a suitable cart for transportation.

- (8) If spinner assembly 837-16 is installed, refer to Figure 3-45 and perform the following steps for the spinner bulkhead removal.
 - (a) Record the position of each start lock in relation to its matching blade.
 - (b) Remove the bolts, nuts, and washers that attach the bulkhead to a ring and spinner mounting plate.
 - (c) Remove the two-piece spinner mounting plate, spinner bulkhead, and ring from the engine flange.

- F. Removing the EHC-A3(MV,V)F-2B Propeller using a spacer as installed on, but not limited to, the Beech 95-55, -A55, -B55, Colemill Baron Aircraft Engines, and Aero Commander Aircraft
Refer to Figure 3-10 and 3-11.

NOTE: If the propeller is equipped with an anti-ice or a de-ice system, follow the manufacturer's instructions for removing the components necessary for propeller removal.

CAUTION 1: INSTRUCTIONS AND PROCEDURES IN THIS SECTION MAY INVOLVE PROPELLER CRITICAL PARTS. REFER TO THE INTRODUCTION CHAPTER OF THIS MANUAL FOR INFORMATION ABOUT PROPELLER CRITICAL PARTS. REFER TO THE ILLUSTRATED PARTS LIST CHAPTER OF THE APPLICABLE OVERHAUL MANUAL(S) FOR THE IDENTIFICATION OF SPECIFIC PROPELLER CRITICAL PARTS.

CAUTION 2: TO PREVENT DAMAGE TO THE BLADE AND BLADE PAINT, WRAP THE BLADE SHANKS IN SEVERAL LAYERS OF MASKING OR DUCT TAPE BEFORE REMOVING THE DOME.

- (1) Spinner dome removal
- (a) Remove the screws and washers that secure the spinner dome to the spinner bulkhead.
 - (b) Remove the spinner dome.
 - (c) Remove layers of masking or duct tape from each blade shank, if applicable.

WARNING 1: DURING ENGINE INSTALLATION OR REMOVAL, USING THE PROPELLER TO SUPPORT THE WEIGHT OF THE ENGINE IS NOT AUTHORIZED. UNAPPROVED INSTALLATION AND REMOVAL TECHNIQUES MAY CAUSE DAMAGE TO THE PROPELLER THAT MAY LEAD TO FAILURE AND RESULT IN AN AIRCRAFT ACCIDENT.

WARNING 2: DURING PROPELLER REMOVAL, AIRFRAME MANUFACTURER'S MANUALS AND PROCEDURES MUST BE FOLLOWED BECAUSE THEY MAY CONTAIN ISSUES VITAL TO AIRCRAFT SAFETY THAT ARE NOT CONTAINED IN THIS MANUAL OR THE HARTZELL PROPELLER OVERHAUL MANUAL.

- (2) Cut and remove the safety wire on the propeller mounting studs.

WARNING: MAKE SURE THE SLING IS RATED UP TO 800 POUNDS (362.99 KG.) TO SUPPORT THE WEIGHT OF THE PROPELLER ASSEMBLY DURING REMOVAL.

- (3) Support the propeller assembly with a sling.
- (4) Remove and discard the lock nut and washer from the end of each mounting stud.

CAUTION: USE ADEQUATE PRECAUTIONS TO PROTECT THE PROPELLER ASSEMBLY FROM DAMAGE WHEN IT IS REMOVED FROM THE AIRCRAFT ENGINE AND WHEN IT IS STORED.

- (5) Using the support sling, lift the propeller from the mounting flange.
- (6) Remove and discard the propeller mounting O-ring.
- (7) Put the propeller, with attached spacer (Figure 3-12), on a suitable cart for transportation.

- G. Removing the K Flange Propeller Models
HC-A3(MV,V)K-2() ()
Refer to Figure 3-13.

NOTE: If the propeller is equipped with an anti-ice or a de-ice system, follow the manufacturer's instructions for removing the components necessary for propeller removal.

CAUTION 1: INSTRUCTIONS AND PROCEDURES IN THIS SECTION MAY INVOLVE PROPELLER CRITICAL PARTS. REFER TO THE INTRODUCTION CHAPTER OF THIS MANUAL FOR INFORMATION ABOUT PROPELLER CRITICAL PARTS. REFER TO THE ILLUSTRATED PARTS LIST CHAPTER OF THE APPLICABLE OVERHAUL MANUAL(S) FOR THE IDENTIFICATION OF SPECIFIC PROPELLER CRITICAL PARTS.

CAUTION 2: TO PREVENT DAMAGE TO THE BLADE AND BLADE PAINT, WRAP THE BLADE SHANKS IN SEVERAL LAYERS OF MASKING OR DUCT TAPE BEFORE REMOVING THE SPINNER DOME.

- (1) Spinner dome removal
- (a) Remove the screws and washers that secure the spinner dome to the spinner bulkhead.
 - (b) Remove the spinner dome.
 - (c) Remove layers of masking or duct tape from each blade shank, if applicable.

WARNING 1: DURING ENGINE INSTALLATION OR REMOVAL, USING THE PROPELLER TO SUPPORT THE WEIGHT OF THE ENGINE IS NOT AUTHORIZED. UNAPPROVED INSTALLATION AND REMOVAL TECHNIQUES MAY CAUSE DAMAGE TO THE PROPELLER THAT MAY LEAD TO FAILURE AND RESULT IN AN AIRCRAFT ACCIDENT.

WARNING 2: DURING PROPELLER REMOVAL, AIRFRAME MANUFACTURER'S MANUALS AND PROCEDURES MUST BE FOLLOWED BECAUSE THEY MAY CONTAIN ISSUES VITAL TO AIRCRAFT SAFETY THAT ARE NOT CONTAINED IN THIS MANUAL OR IN THE HARTZELL PROPELLER OVERHAUL MANUALS.

WARNING 3: FOR SAFETY REASONS, THE PROPELLER MUST BE PUT IN THE FEATHER POSITION BEFORE IT IS REMOVED FROM THE AIRCRAFT.

- (2) Routine propeller engine shutdown will engage the start lock units, preventing the propeller from feathering. For purposes of propeller removal, the propeller should be put in feather position during engine shutdown. If this was not accomplished, then the propeller may be feathered as follows:

CAUTION: DO NOT PUT THE BLADE PADDLE IN THE AREA OF THE DE-ICE BOOT WHEN APPLYING TORQUE TO A BLADE ASSEMBLY. PUT THE BLADE PADDLE IN THE THICKEST AREA OF THE BLADE, JUST OUTBOARD OF THE DE-ICE BOOT. USE ONE BLADE PADDLE PER BLADE.

- (a) Rotate the blades simultaneously to a slightly lower pitch to disengage the start lock plates from the start lock units.
- (b) Retract the start lock pins and hold them in place with a heavy wire inserted through the hole of each start lock housing.
- (c) Slowly and carefully allow the blades to rotate to high/feather pitch.

WARNING: MAKE SURE THE SLING IS RATED UP TO 800 POUNDS (363 KG.) TO SUPPORT THE WEIGHT OF THE PROPELLER ASSEMBLY DURING REMOVAL.

- (3) Support the propeller assembly with a sling.
- (4) Remove the safety wire on the propeller mounting bolts.

CAUTION: DISCARD THE PROPELLER MOUNTING BOLTS AND WASHERS IF THEY ARE DAMAGED OR CORRODED, OR IF THE PROPELLER IS REMOVED FOR OVERHAUL.

- (5) Record the position of each start lock in relation to its matching blade.
- (6) Remove the start locks to gain access to the mounting bolts.
- (7) Unthread the propeller mounting bolts from the engine.
- (8) Remove three of the propeller mounting bolts and washers.

NOTE 1: Three of the propeller mounting bolts and washers cannot be removed from the propeller hub due to interference with other propeller parts.

NOTE 2: For propeller removals between overhaul intervals, mounting bolts and washers may be reused if they are not damaged or corroded.

CAUTION: USE ADEQUATE PRECAUTIONS TO PROTECT THE PROPELLER ASSEMBLY FROM DAMAGE WHEN IT IS REMOVED FROM THE AIRCRAFT ENGINE AND WHEN IT IS STORED.

- (9) Using the support sling, lift the propeller from the mounting flange.
- (10) Remove and discard the shaft O-ring.
- (11) Remove the shim.

- (12) If the spinner was manufactured by Hartzell Propeller:
- (a) Do not remove the spinner adapter ring.
 - (b) Visually inspect the spinner adapter ring for cracks.
 - (c) If cracks are found in the spinner adapter ring, remove it from the engine starter ring gear and replace it.
- (13) Put the propeller on a suitable cart for transportation.

H. Removing the F Flange Propeller Models BHC-A2(MV,V)F-3
Refer to Figure 3-14.

NOTE: If the propeller is equipped with an anti-ice or a de-ice system, follow the manufacturer's instructions for removing the components necessary for propeller removal.

CAUTION 1: INSTRUCTIONS AND PROCEDURES IN THIS SECTION MAY INVOLVE PROPELLER CRITICAL PARTS. REFER TO THE INTRODUCTION CHAPTER OF THIS MANUAL FOR INFORMATION ABOUT PROPELLER CRITICAL PARTS. REFER TO THE ILLUSTRATED PARTS LIST CHAPTER OF THE APPLICABLE OVERHAUL MANUAL(S) FOR THE IDENTIFICATION OF SPECIFIC PROPELLER CRITICAL PARTS.

CAUTION 2: TO PREVENT DAMAGE TO THE BLADE AND BLADE PAINT, WRAP THE BLADE SHANKS IN SEVERAL LAYERS OF MASKING OR DUCT TAPE BEFORE REMOVING THE DOME.

- (1) Spinner dome removal
- (a) Remove the screws and washers that secure the spinner dome to the spinner bulkhead.
 - (b) Remove the spinner dome.
 - (c) Remove layers of masking or duct tape from each blade shank, if applicable.
- (2) Disconnect the propeller beta ring from the carbon block assembly and lever. Refer to Figure 3-14.
- (a) Disconnect the outer end of the lever from the control push-pull fitting.
 - (b) Disconnect the lever from the beta valve spool.

- (c) Remove the carbon block assembly and lever from the beta ring.

NOTE: Replace the carbon block unit at overhaul, or if the side clearance between the beta ring and carbon block exceeds 0.010 inch (0.25 mm).

WARNING 1: DURING ENGINE INSTALLATION OR REMOVAL, USING THE PROPELLER TO SUPPORT THE WEIGHT OF THE ENGINE IS NOT AUTHORIZED. UNAPPROVED INSTALLATION AND REMOVAL TECHNIQUES MAY CAUSE DAMAGE TO THE PROPELLER THAT MAY LEAD TO FAILURE AND RESULT IN AN AIRCRAFT ACCIDENT.

WARNING 2: DURING PROPELLER REMOVAL, AIRFRAME MANUFACTURER'S MANUALS AND PROCEDURES MUST BE FOLLOWED BECAUSE THEY MAY CONTAIN ISSUES VITAL TO AIRCRAFT SAFETY THAT ARE NOT CONTAINED IN THIS MANUAL OR THE HARTZELL PROPELLER OVERHAUL MANUAL.

- (3) Remove the safety wire on the propeller mounting bolts.

WARNING: MAKE SURE THE SLING IS RATED UP TO 800 POUNDS (362.99 KG.) TO SUPPORT THE WEIGHT OF THE PROPELLER ASSEMBLY DURING REMOVAL.

- (4) Support the propeller assembly with a sling.

NOTE 1: To allow rotation of the propeller for ease of bolt removal, supporting the propeller with a sling may be delayed until all but one mounting bolt and washer has been removed.

NOTE 2: If the propeller will be reinstalled, and it has been dynamically balanced, make an identifying mark (with a felt-tipped pen only) on the propeller hub and a matching mark on the engine flange to ensure proper positioning of the propeller during reinstallation. This will prevent dynamic imbalance.

- (5) Use a beta system puller CST-2987 to compress the beta system spring and pull the beta ring forward to expose the propeller mounting bolts and washers.

CAUTION: DISCARD THE PROPELLER MOUNTING BOLTS AND WASHERS IF THEY ARE DAMAGED OR CORRODED, WHEN THE PROPELLER IS REMOVED FOR OVERHAUL.

- (6) Remove the propeller mounting bolts and washers.

NOTE: For propeller removals between overhaul intervals, mounting bolts and washers may be reused if they are not damaged or corroded.

CAUTION: USE ADEQUATE PRECAUTIONS TO PROTECT THE PROPELLER ASSEMBLY FROM DAMAGE WHEN IT IS REMOVED FROM THE AIRCRAFT ENGINE AND WHEN IT IS STORED.

- (7) Using the support sling, lift the propeller from the mounting flange.

- (8) Remove and discard the engine flange O-ring.

- (9) Decompress and remove the beta system puller.

- (10) Put the propeller on a suitable cart for transportation.

- (11) Governor, beta valve, and stud removal

Refer to Figure 3-18.

- (a) Loosen the four nuts that hold the governor onto the beta valve and engine.
- (b) Lift the governor off the beta valve and engine.
- (c) Remove the governor shaft extension from the engine accessory drive shaft.
- (d) Remove and discard the governor gasket.
- (e) Slide the beta valve off the engine and studs.
- (f) Remove and discard the governor gasket.
- (g) Do not remove the four studs from the engine case unless they are damaged or corroded.

NOTE: Studs must be removed only by a certified mechanic in accordance with the engine manufacturer's requirements.

- I. Removing F Flange Propeller Models HC-A3(MV,V)F-3L
Refer to Figure 3-20.

NOTE: If the propeller is equipped with an anti-ice or a de-ice system, follow the manufacturer's instructions for removing the components necessary for propeller removal.

CAUTION 1: INSTRUCTIONS AND PROCEDURES IN THIS SECTION MAY INVOLVE PROPELLER CRITICAL PARTS. REFER TO THE INTRODUCTION CHAPTER OF THIS MANUAL FOR INFORMATION ABOUT PROPELLER CRITICAL PARTS. REFER TO THE ILLUSTRATED PARTS LIST CHAPTER OF THE APPLICABLE OVERHAUL MANUAL(S) FOR THE IDENTIFICATION OF SPECIFIC PROPELLER CRITICAL PARTS.

CAUTION 2: TO PREVENT DAMAGE TO THE BLADE AND BLADE PAINT, WRAP THE BLADE SHANKS IN SEVERAL LAYERS OF MASKING OR DUCT TAPE BEFORE REMOVING THE DOME.

- (1) Spinner dome removal
 - (a) Remove the screws and washers that secure the spinner dome to the spinner bulkhead.
 - (b) Remove the spinner dome.
 - (c) Remove layers of masking or duct tape from each blade shank, if applicable.
- (2) Disconnect the propeller beta ring from the carbon block assembly and lever. Refer to Figure 3-20.
 - (a) Disconnect the outer end of the lever from the control push-pull fitting.
 - (b) Disconnect the lever from the beta valve spool.
 - (c) Remove the carbon block assembly and lever from the beta ring.

NOTE: Replace the carbon block unit at overhaul, or if the side clearance between the beta ring and carbon block exceeds 0.010 inch (0.25 mm).

WARNING 1: DURING ENGINE INSTALLATION OR REMOVAL, USING THE PROPELLER TO SUPPORT THE WEIGHT OF THE ENGINE IS NOT AUTHORIZED. UNAPPROVED INSTALLATION AND REMOVAL TECHNIQUES MAY CAUSE DAMAGE TO THE PROPELLER THAT MAY LEAD TO FAILURE AND RESULT IN AN AIRCRAFT ACCIDENT.

WARNING 2: DURING PROPELLER REMOVAL, AIRFRAME MANUFACTURER'S MANUALS AND PROCEDURES MUST BE FOLLOWED BECAUSE THEY MAY CONTAIN ISSUES VITAL TO AIRCRAFT SAFETY THAT ARE NOT CONTAINED IN THIS MANUAL OR THE HARTZELL PROPELLER OVERHAUL MANUAL.

(3) Remove the safety wire on the propeller mounting nuts.

WARNING: MAKE SURE THE SLING IS RATED UP TO 800 POUNDS (362.99 KG.) TO SUPPORT THE WEIGHT OF THE PROPELLER ASSEMBLY DURING REMOVAL.

(4) Support the propeller assembly with a sling.

NOTE 1: To allow rotation of the propeller for ease of mounting nut removal, supporting the propeller with a sling may be delayed until all but two mounting nuts and washers have been removed.

NOTE 2: If the propeller will be reinstalled, and it has been dynamically balanced, make an identifying mark (with a felt-tipped pen only) on the propeller hub and a matching mark on the engine flange to ensure proper positioning of the propeller during reinstallation. This will prevent dynamic imbalance.

- (5) Use a beta system puller CST-2987 to compress the beta system spring and pull the beta ring forward to expose the propeller mounting nuts and washers.
- (6) Remove and discard the elastic nut and washer from the end of each mounting stud.

CAUTION: USE ADEQUATE PRECAUTIONS TO PROTECT THE PROPELLER ASSEMBLY FROM DAMAGE WHEN IT IS REMOVED FROM THE AIRCRAFT ENGINE AND WHEN IT IS STORED.

- (7) Using the support sling, lift the propeller from the mounting flange.

NOTE: The spacer between the engine and propeller should stay on the propeller studs during the propeller removal.

- (8) Remove and discard the engine flange O-ring.
- (9) Decompress and remove the beta system puller.
- (10) Put the propeller on a suitable cart for transportation.

- J. Removing F Flange Propeller Models (E,P)HC-A3(MV,V)F-4()
Refer to Figure 3-23.

NOTE: If the propeller is equipped with an anti-ice or a de-ice system, follow the manufacturer's instructions for removing the components necessary for propeller removal.

CAUTION 1: INSTRUCTIONS AND PROCEDURES IN THIS SECTION MAY INVOLVE PROPELLER CRITICAL PARTS. REFER TO THE INTRODUCTION CHAPTER OF THIS MANUAL FOR INFORMATION ABOUT PROPELLER CRITICAL PARTS. REFER TO THE ILLUSTRATED PARTS LIST CHAPTER OF THE APPLICABLE OVERHAUL MANUAL(S) FOR THE IDENTIFICATION OF SPECIFIC PROPELLER CRITICAL PARTS.

CAUTION 2: TO PREVENT DAMAGE TO THE BLADE AND BLADE PAINT, WRAP THE BLADE SHANKS IN SEVERAL LAYERS OF MASKING OR DUCT TAPE BEFORE REMOVING THE SPINNER DOME.

- (1) Spinner dome removal

NOTE: Propeller model EHC-A3(MV,V)F-4 does not have a spinner installed.

- (a) Remove the screws and washers that secure the spinner to the spinner bulkhead.
- (b) Remove the spinner dome.
- (c) Remove layers of masking or duct tape from each blade shank, if applicable.

WARNING 1: DURING ENGINE INSTALLATION OR REMOVAL, USING THE PROPELLER TO SUPPORT THE WEIGHT OF THE ENGINE IS NOT AUTHORIZED. UNAPPROVED INSTALLATION AND REMOVAL TECHNIQUES MAY CAUSE DAMAGE TO THE PROPELLER THAT MAY LEAD TO FAILURE AND RESULT IN AN AIRCRAFT ACCIDENT.

WARNING 2: DURING PROPELLER REMOVAL, AIRFRAME MANUFACTURER'S MANUALS AND PROCEDURES MUST BE FOLLOWED BECAUSE THEY MAY CONTAIN ISSUES VITAL TO AIRCRAFT SAFETY THAT ARE NOT CONTAINED IN THIS MANUAL OR IN THE HARTZELL PROPELLER OVERHAUL MANUALS.

(2) Remove the safety wire on the propeller mounting bolts.

WARNING: MAKE SURE THE SLING IS RATED UP TO 800 POUNDS (362.99 KG.) TO SUPPORT THE WEIGHT OF THE PROPELLER ASSEMBLY DURING REMOVAL.

(3) Support the propeller assembly with a sling.

NOTE 1: To allow rotation of the propeller for ease of bolt removal, supporting the propeller with a sling may be delayed until all but two mounting bolts and washers have been removed.

NOTE 2: If the propeller will be reinstalled, and it has been dynamically balanced, make an identifying mark (with a felt-tipped pen only) on the propeller hub and a matching mark on the engine flange to ensure proper positioning of the propeller during reinstallation. This will prevent dynamic imbalance.

CAUTION: DISCARD THE PROPELLER MOUNTING BOLTS AND WASHERS IF THEY ARE DAMAGED OR CORRODED, OR IF THE PROPELLER IS REMOVED FOR OVERHAUL.

(4) Remove the propeller mounting bolts and washers.

NOTE: For propeller removals between overhaul intervals, mounting bolts and washers may be reused if they are not damaged or corroded.

- (5) If the spinner assembly is installed, perform the following steps for spinner bulkhead removal. Refer to Figure 3-45.
 - (a) Remove the bolts, nuts and washers that attach the bulkhead to a ring and spinner mounting plate.
 - (b) Remove the two-piece spinner mounting plate, spinner bulkhead, and ring from the engine flange.

CAUTION: USE ADEQUATE PRECAUTIONS TO PROTECT THE PROPELLER ASSEMBLY FROM DAMAGE WHEN IT IS REMOVED FROM THE AIRCRAFT ENGINE AND WHEN IT IS STORED.

- (6) Using the support sling, lift the propeller from the mounting flange.
- (7) Remove and discard the shaft O-ring.
- (8) Put the propeller and spinner dome on a suitable cart for transportation.

- K. Removing K Flange Propeller Models HC-A3(MV,V)K-4
Refer to Figure 3-23.

NOTE: If the propeller is equipped with an anti-ice or a de-ice system, follow the manufacturer's instructions for removing the components necessary for propeller removal.

CAUTION 1: INSTRUCTIONS AND PROCEDURES IN THIS SECTION MAY INVOLVE PROPELLER CRITICAL PARTS. REFER TO THE INTRODUCTION CHAPTER OF THIS MANUAL FOR INFORMATION ABOUT PROPELLER CRITICAL PARTS. REFER TO THE ILLUSTRATED PARTS LIST CHAPTER OF THE APPLICABLE OVERHAUL MANUAL(S) FOR THE IDENTIFICATION OF SPECIFIC PROPELLER CRITICAL PARTS.

CAUTION 2: TO PREVENT DAMAGE TO THE BLADE AND BLADE PAINT, WRAP THE BLADE SHANKS IN SEVERAL LAYERS OF MASKING OR DUCT TAPE BEFORE REMOVING THE SPINNER DOME.

(1) Spinner dome removal

- (a) Remove the screws and washers that secure the spinner dome to the spinner bulkhead.
- (b) Remove the spinner dome.
- (c) Remove layers of masking or duct tape from each blade shank, if applicable.

WARNING 1: DURING ENGINE INSTALLATION OR REMOVAL, USING THE PROPELLER TO SUPPORT THE WEIGHT OF THE ENGINE IS NOT AUTHORIZED. UNAPPROVED INSTALLATION AND REMOVAL TECHNIQUES MAY CAUSE DAMAGE TO THE PROPELLER THAT MAY LEAD TO FAILURE AND RESULT IN AN AIRCRAFT ACCIDENT.

WARNING 2: DURING PROPELLER REMOVAL, AIRFRAME MANUFACTURER'S MANUALS AND PROCEDURES MUST BE FOLLOWED BECAUSE THEY MAY CONTAIN ISSUES VITAL TO AIRCRAFT SAFETY THAT ARE NOT CONTAINED IN THIS MANUAL OR IN THE HARTZELL PROPELLER OVERHAUL MANUALS.

(2) Remove the safety wire on the propeller mounting bolts.

WARNING: MAKE SURE THE SLING IS RATED UP TO 800 POUNDS (362.99 KG.) TO SUPPORT THE WEIGHT OF THE PROPELLER ASSEMBLY DURING REMOVAL.

(3) Support the propeller assembly with a sling.

NOTE 1: To allow rotation of the propeller for ease of bolt removal, supporting the propeller with a sling may be delayed until all but two mounting bolts and washers have been removed.

NOTE 2: If the propeller will be reinstalled, and it has been dynamically balanced, make an identifying mark (with a felt-tipped pen only) on the propeller hub and a matching mark on the engine flange to ensure proper positioning of the propeller during reinstallation. This will prevent dynamic imbalance.

(4) Remove the propeller mounting bolts from the engine flange.

CAUTION: DISCARD THE PROPELLER MOUNTING BOLTS AND WASHERS IF THEY ARE DAMAGED OR CORRODED, OR IF THE PROPELLER IS REMOVED FOR OVERHAUL.

(5) Remove the propeller mounting bolts and washers.

NOTE 1: Three propeller mounting bolts and washers cannot be removed from the propeller hub due to interference with other propeller parts.

NOTE 2: For propeller removals between overhaul intervals, mounting bolts and washers may be reused if they are not damaged or corroded.

CAUTION: USE ADEQUATE PRECAUTIONS TO PROTECT THE PROPELLER ASSEMBLY FROM DAMAGE WHEN IT IS REMOVED FROM THE AIRCRAFT ENGINE AND WHEN IT IS STORED.

- (6) Using the support sling, lift the propeller from the mounting flange.
- (7) Remove the shim.
- (8) Remove and discard the shaft O-ring.
- (9) If the spinner was manufactured by Hartzell Propeller:
 - (a) Do not remove the spinner adapter ring.
 - (b) Visually inspect the spinner adapter ring for cracks.
 - (c) If cracks are found in the spinner adapter ring, remove it from the engine starter ring gear and replace it.
- (10) Put the propeller and spinner dome on a suitable cart for transportation.

- L. Removing F Flange Propeller Models HC-A3(MV,V)F-5A(L)
Refer to Figure 3-24.

NOTE: If the propeller is equipped with a de-ice system, follow the manufacturer's instructions for removing whichever components are necessary for propeller removal.

CAUTION: INSTRUCTIONS AND PROCEDURES IN THIS SECTION MAY INVOLVE PROPELLER CRITICAL PARTS. REFER TO THE INTRODUCTION CHAPTER OF THIS MANUAL FOR INFORMATION ABOUT PROPELLER CRITICAL PARTS. REFER TO THE ILLUSTRATED PARTS LIST CHAPTER OF THE APPLICABLE OVERHAUL MANUAL(S) FOR THE IDENTIFICATION OF SPECIFIC PROPELLER CRITICAL PARTS.

- (1) Remove the spinner dome
 - (a) Remove the screws and washers that secure the bulkhead.
 - (b) Remove the spinner dome
 - (c) Remove layers of masking or duct tape from each blade shank, if applicable.

CAUTION: THE BETA TUBE MUST BE REMOVED BEFORE THE PROPELLER ASSEMBLY IS REMOVED FROM THE AIRCRAFT. REFER TO THE AIRCRAFT MAINTENANCE INSTRUCTION MANUAL.

- (2) Remove the beta tube.

WARNING 1: DURING ENGINE INSTALLATION OR REMOVAL, USING THE PROPELLER TO SUPPORT THE WEIGHT OF THE ENGINE IS NOT AUTHORIZED. UNAPPROVED INSTALLATION AND REMOVAL TECHNIQUES MAY CAUSE DAMAGE TO THE PROPELLER THAT MAY LEAD TO FAILURE AND RESULT IN AN AIRCRAFT ACCIDENT.

WARNING 2: DURING PROPELLER REMOVAL, AIRFRAME MANUFACTURER'S MANUALS AND PROCEDURES MUST BE FOLLOWED BECAUSE THEY MAY CONTAIN ISSUES VITAL TO AIRCRAFT SAFETY THAT ARE NOT CONTAINED IN THIS MANUAL OR THE HARTZELL PROPELLER OVERHAUL MANUAL 114C (61-10-14).

WARNING 3: FOR SAFETY REASONS, THE PROPELLER MUST BE PUT IN FEATHER POSITION BEFORE IT IS REMOVED FROM THE AIRCRAFT.

- (3) Routine propeller engine shutdown will engage the start lock units, preventing the propeller from feathering. For purposes of propeller removal, the propeller should be put in feather position during engine shutdown. If this was not accomplished, then the propeller may be feathered as follows:

CAUTION: DO NOT PUT THE BLADE PADDLE IN THE AREA OF THE DE-ICE BOOT WHEN APPLYING TORQUE TO A BLADE ASSEMBLY. PUT THE BLADE PADDLE IN THE THICKEST AREA OF THE BLADE, JUST OUTBOARD OF THE DE-ICE BOOT. USE ONE BLADE PADDLE PER BLADE.

- (a) Rotate the blades simultaneously to a slightly lower pitch to disengage the start lock plates from the start lock units.
- (b) Retract the start lock pins and hold them in place with a heavy wire inserted through the hole of each start lock housing.
- (c) Slowly and carefully allow the blades to rotate to high/feather pitch.
- (4) Remove the safety wire on the propeller mounting bolts.

WARNING: MAKE SURE THE SLING IS RATED UP TO 800 POUNDS (362.99 KG.) TO SUPPORT THE WEIGHT OF THE PROPELLER ASSEMBLY DURING REMOVAL.

(5) Support the propeller assembly with a sling.

NOTE 1: To allow rotation of the propeller for ease of bolt removal, supporting the propeller with a sling may be delayed until all but two mounting nuts and washers have been removed.

NOTE 2: If the propeller will be reinstalled, and it has been dynamically balanced, make an identifying mark (with a felt-tipped pen only) on the propeller hub and a matching mark on the engine flange to ensure proper positioning of the propeller during reinstallation. This will prevent dynamic imbalance.

CAUTION: DISCARD THE PROPELLER MOUNTING BOLTS AND WASHERS IF THEY ARE DAMAGED OR CORRODED, OR WHEN THE PROPELLER IS REMOVED FOR OVERHAUL.

(6) Remove the propeller mounting bolts and washers.

NOTE: If the propeller is removed between overhaul intervals, mounting bolts and washers may be reused if they are not damaged or corroded.

CAUTION: USE ADEQUATE PRECAUTIONS TO PROTECT THE PROPELLER ASSEMBLY FROM DAMAGE WHEN IT IS REMOVED FROM THE AIRCRAFT ENGINE AND WHEN IT IS STORED.

(7) Using the support sling, lift the propeller from the mounting flange.

(8) Remove and discard propeller mounting O-ring.

(9) Put the propeller on a suitable cart for transportation.

- M. Removing F Flange Propeller Models (P)HC-A3(MV,V)F-5R
Refer to Figure 3-25.

NOTE: If the propeller is equipped with an anti-ice or a de-ice system, follow the manufacturer's instructions for removing the components necessary for propeller removal.

CAUTION 1: INSTRUCTIONS AND PROCEDURES IN THIS SECTION MAY INVOLVE PROPELLER CRITICAL PARTS. REFER TO THE INTRODUCTION CHAPTER OF THIS MANUAL FOR INFORMATION ABOUT PROPELLER CRITICAL PARTS. REFER TO THE ILLUSTRATED PARTS LIST CHAPTER OF THE APPLICABLE OVERHAUL MANUAL(S) FOR THE IDENTIFICATION OF SPECIFIC PROPELLER CRITICAL PARTS.

CAUTION 2: TO PREVENT DAMAGE TO THE BLADE AND BLADE PAINT, WRAP THE BLADE SHANKS IN SEVERAL LAYERS OF MASKING OR DUCT TAPE BEFORE REMOVING THE DOME.

- (1) Spinner dome removal
 - (a) Remove the screws and washers that secure the spinner dome to the spinner bulkhead.
 - (b) Remove the spinner dome.
 - (c) Remove layers of masking or duct tape from each blade shank, if applicable.
- (2) Disconnect the propeller beta ring from the carbon block assembly and lever. Refer to Figure 3-25.
 - (a) Disconnect the outer end of the lever from the control push-pull fitting.
 - (b) Disconnect the lever from the beta valve spool.
 - (c) Remove the carbon block assembly and lever from the beta ring.

NOTE: Replace the carbon block unit at overhaul, or if the side clearance between the beta ring and carbon block exceeds 0.010 inch (0.25 mm).

WARNING 1: DURING ENGINE INSTALLATION OR REMOVAL, USING THE PROPELLER TO SUPPORT THE WEIGHT OF THE ENGINE IS NOT AUTHORIZED. UNAPPROVED INSTALLATION AND REMOVAL TECHNIQUES MAY CAUSE DAMAGE TO THE PROPELLER THAT MAY LEAD TO FAILURE AND RESULT IN AN AIRCRAFT ACCIDENT.

WARNING 2: DURING PROPELLER REMOVAL, AIRFRAME MANUFACTURER'S MANUALS AND PROCEDURES MUST BE FOLLOWED BECAUSE THEY MAY CONTAIN ISSUES VITAL TO AIRCRAFT SAFETY THAT ARE NOT CONTAINED IN THIS MANUAL OR THE HARTZELL PROPELLER OVERHAUL MANUAL.

WARNING 3: FOR SAFETY REASONS, THE PROPELLER MUST BE PUT IN FEATHER POSITION BEFORE IT IS REMOVED FROM THE AIRCRAFT.

- (3) Routine propeller engine shutdown will engage the start lock units, preventing the propeller from feathering. For purposes of propeller removal, the propeller should be put in feather position during engine shutdown. If this was not accomplished, then the propeller may be feathered as follows:

CAUTION: DO NOT PUT THE BLADE PADDLE IN THE AREA OF THE DE-ICE BOOT WHEN APPLYING TORQUE TO A BLADE ASSEMBLY. PUT THE BLADE PADDLE IN THE THICKEST AREA OF THE BLADE, JUST OUTBOARD OF THE DE-ICE BOOT. USE ONE BLADE PADDLE PER BLADE.

- (a) Rotate the blades simultaneously to a slightly lower pitch to disengage the start lock plates from the start lock units.
 - (b) Retract the start lock pins and hold them in place with a heavy wire inserted through the hole of each start lock housing.
 - (c) Slowly and carefully allow the blades to rotate to high/feather pitch.
- (4) Remove the safety wire on the propeller mounting nuts.

WARNING: MAKE SURE THE SLING IS RATED UP TO 800 POUNDS (362.99 KG.) TO SUPPORT THE WEIGHT OF THE PROPELLER ASSEMBLY DURING REMOVAL.

- (5) Support the propeller assembly with a sling.

NOTE 1: To allow rotation of the propeller for ease of nut removal, supporting the propeller with a sling may be delayed until all but two mounting nuts and washers have been removed.

NOTE 2: If the propeller will be reinstalled, and it has been dynamically balanced, make an identifying mark (with a felt-tipped pen only) on the propeller hub and a matching mark on the engine flange to ensure proper positioning of the propeller during reinstallation. This will prevent dynamic imbalance.

- (6) Use a beta system puller CST-2987 to compress the beta system spring and pull the beta ring forward to expose the propeller mounting nuts and washers.

- (7) Remove and discard the mounting nut and washer from the end of each mounting stud.

CAUTION: USE ADEQUATE PRECAUTIONS TO PROTECT THE PROPELLER ASSEMBLY FROM DAMAGE WHEN IT IS REMOVED FROM THE AIRCRAFT ENGINE AND WHEN IT IS STORED.

- (8) Using the support sling, lift the propeller from the mounting flange.
- (9) Remove and discard the engine flange O-ring.
- (10) Decompress and remove the beta system puller.
- (11) Put the propeller on a suitable cart for transportation.

- N. Removing the 20 Splined Propeller Model
HA-A2(MV,V)20-1B

Refer to Figure 3-27.

NOTE: If the propeller is equipped with an anti-ice or a de-ice system, follow the manufacturer's instructions for removing the components necessary for propeller removal.

WARNING 1: DURING ENGINE INSTALLATION OR REMOVAL, USING THE PROPELLER TO SUPPORT THE WEIGHT OF THE ENGINE IS NOT AUTHORIZED. UNAPPROVED INSTALLATION AND REMOVAL TECHNIQUES MAY CAUSE DAMAGE TO THE PROPELLER THAT MAY LEAD TO FAILURE AND RESULT IN AN AIRCRAFT ACCIDENT.

WARNING 2: DURING PROPELLER REMOVAL, AIRFRAME MANUFACTURER'S MANUALS AND PROCEDURES MUST BE FOLLOWED BECAUSE THEY MAY CONTAIN ISSUES VITAL TO AIRCRAFT SAFETY THAT ARE NOT CONTAINED IN THIS MANUAL OR IN THE HARTZELL PROPELLER PROPELLER INC. OVERHAUL MANUALS.

CAUTION 1: INSTRUCTIONS AND PROCEDURES IN THIS SECTION MAY INVOLVE PROPELLER CRITICAL PARTS. REFER TO THE INTRODUCTION CHAPTER OF THIS MANUAL FOR INFORMATION ABOUT PROPELLER CRITICAL PARTS. REFER TO THE ILLUSTRATED PARTS LIST CHAPTER OF THE APPLICABLE OVERHAUL MANUAL(S) FOR THE IDENTIFICATION OF SPECIFIC PROPELLER CRITICAL PARTS.

CAUTION 2: OIL WILL FLOW OUT OF THE PROPELLER WHEN THE PISTON IS REMOVED. PUT A DRIP PAN UNDER THE PROPELLER TO CATCH THE EXCESS OIL.

- (2) Piston Removal (Refer to Figures 3-27 and 3-28.)
- (a) Remove the piston nut.
 - (b) Remove the safety wire from the link pin units.
 - (c) Remove the safety screw from each link pin unit.
 - (d) Remove each link pin unit.
 - (e) The piston ears and guide collar should have corresponding index numbers (1 and 2) impression-stamped or marked with a felt-tipped pen. If they are not marked, number them with a felt-tipped pen.

NOTE: This will insure that the components are reassembled in their original location.

- (f) Slide the link arms out of the piston slots.
 - (g) Slide the piston off the cylinder.
- (3) Pitch adjustment assembly removal
- (a) Remove the ring retention plate screw safety wire.
 - (b) Remove the ring retention plate screws.
 - (c) Remove the plate.
 - (d) Remove the split retainer from the recess in the cylinder.
 - (e) Remove the pitch adjustment assembly from the cylinder.
- (4) Remove the hub lock safety pin. Refer to Figure 3-31.
- (5) Support the propeller assembly with a sling.

WARNING: MAKE SURE THE SLING IS RATED UP TO 800 POUNDS (363 KG) TO SUPPORT THE WEIGHT OF THE PROPELLER ASSEMBLY DURING REMOVAL.

CAUTION: USE ADEQUATE PRECAUTIONS TO PROTECT THE PROPELLER ASSEMBLY FROM DAMAGE WHEN IT IS REMOVED FROM THE AIRCRAFT ENGINE AND WHEN IT IS STORED.

- (6) Completely loosen the shaft nut from the engine shaft threads.

NOTE: Because the shaft nut is pulling the propeller hub off the tapered rear cone, there will be significant resistance to initial loosening of the shaft nut.

- (7) Using the support sling, slide the propeller from the engine splined shaft and lift the propeller from the engine.
- (8) Remove and discard the rear cone O-ring. Refer to Figure 3-30.
- (9) Remove the rear cone. Refer to Figure 3-30.
- (10) Put the propeller and associated parts on a suitable cart for transportation.

- O. Removing the 20 Splined Propeller Models
HC-A2(MV,V)20-1A
Refer to Figure 3-33.

NOTE: If the propeller is equipped with an anti-ice or a de-ice system, follow the manufacturer's instructions for removing the components necessary for propeller removal.

CAUTION 1: INSTRUCTIONS AND PROCEDURES IN THIS SECTION MAY INVOLVE PROPELLER CRITICAL PARTS. REFER TO THE INTRODUCTION CHAPTER OF THIS MANUAL FOR INFORMATION ABOUT PROPELLER CRITICAL PARTS. REFER TO THE ILLUSTRATED PARTS LIST CHAPTER OF THE APPLICABLE OVERHAUL MANUAL(S) FOR THE IDENTIFICATION OF SPECIFIC PROPELLER CRITICAL PARTS.

CAUTION 2: TO PREVENT DAMAGE TO THE BLADE AND BLADE PAINT, WRAP THE BLADE SHANKS IN SEVERAL LAYERS OF MASKING OR DUCT TAPE BEFORE REMOVING THE SPINNER DOME.

- (1) Spinner dome removal
- (a) Remove the screws and washers that secure the spinner dome to the spinner bulkhead.
 - (b) Remove the spinner dome.
 - (c) Remove layers of masking or duct tape from each blade shank, if applicable.

WARNING 1: DURING ENGINE INSTALLATION OR REMOVAL, USING THE PROPELLER TO SUPPORT THE WEIGHT OF THE ENGINE IS NOT AUTHORIZED. UNAPPROVED INSTALLATION AND REMOVAL TECHNIQUES MAY CAUSE DAMAGE TO THE PROPELLER THAT MAY LEAD TO FAILURE AND RESULT IN AN AIRCRAFT ACCIDENT.

WARNING 2: DURING PROPELLER REMOVAL, AIRFRAME MANUFACTURER'S MANUALS AND PROCEDURES MUST BE FOLLOWED BECAUSE THEY MAY CONTAIN ISSUES VITAL TO AIRCRAFT SAFETY THAT ARE NOT CONTAINED IN THIS MANUAL OR IN THE HARTZELL PROPELLER OVERHAUL MANUALS.

CAUTION: OIL WILL FLOW OUT OF THE PROPELLER WHEN THE PISTON IS REMOVED. PUT A DRIP PAN UNDER THE PROPELLER TO CATCH THE EXCESS OIL.

(2) Piston Removal (Refer to Figure 3-28.)

- (a) Remove the self-locking nut from each piston rod.
- (b) Remove the washer from each piston rod.
- (c) Loosen the set screw in each fork.
- (d) The piston ears, forks, counterweights, and guide collar should have corresponding index numbers (1 and 2) impression-stamped or marked with a felt-tipped pen. If they are not marked, number them with a felt-tipped pen.

NOTE: This will insure that the components are reassembled in their original location.

- (e) Slide the piston away from the hub and to the low pitch position, until the piston rods clear the guide collar.
- (f) Rotate the piston to move the forks away from the clamp, link screws, and pitch change blocks.
- (g) Slide the piston off the cylinder and remove it from the propeller.
- (h) To prevent the loss of the sleeve, fork, and high pitch stop spacers, reinstall the washer and self-locking nut on each piston rod.

- (i) The pitch change blocks should have index numbers (1 and 2) marked with a felt-tipped pen to correspond to the numbers on the piston ears, forks, counterweights, and guide collar. If they are not marked, number them with a felt-tipped pen.

NOTE: This will insure that the components are reassembled in their original location.

- (j) Remove the pitch change block from each clamp linkscrew.
- (3) Remove the hub lock safety pin. Refer to Figure 3-31.
- (4) Using tool BST-2910, completely loosen the hub nut from the engine shaft threads.

NOTE: Because the shaft nut is pulling the propeller hub off the tapered rear cone, there will be significant initial resistance to the loosening of the shaft nut.

WARNING: MAKE SURE THE SLING IS RATED UP TO 800 POUNDS (363 KG.) TO SUPPORT THE WEIGHT OF THE PROPELLER ASSEMBLY DURING REMOVAL.

CAUTION: USE ADEQUATE PRECAUTIONS TO PROTECT THE PROPELLER ASSEMBLY FROM DAMAGE WHEN IT IS REMOVED FROM THE AIRCRAFT ENGINE AND WHEN IT IS STORED.

- (5) Using the support sling, slide the propeller from the engine splined shaft and lift the propeller from the engine.
- (6) Remove and discard the rear cone O-ring.
- (7) Remove the rear cone from the engine shaft.
- (8) Remove the spinner bulkhead from the engine shaft.
- (9) Put the propeller and associated parts on a suitable cart for transportation.

P. Removing the 20 Splined Propeller Models
HC-A3(MV,V)20-1()

Refer to Figure 3-34.

NOTE: If the propeller is equipped with an anti-ice or a de-ice system, follow the manufacturer's instructions for removing the components necessary for propeller removal.

CAUTION 1: INSTRUCTIONS AND PROCEDURES IN THIS SECTION MAY INVOLVE PROPELLER CRITICAL PARTS. REFER TO THE INTRODUCTION CHAPTER OF THIS MANUAL FOR INFORMATION ABOUT PROPELLER CRITICAL PARTS. REFER TO THE ILLUSTRATED PARTS LIST CHAPTER OF THE APPLICABLE OVERHAUL MANUAL(S) FOR THE IDENTIFICATION OF SPECIFIC PROPELLER CRITICAL PARTS.

CAUTION 2: TO PREVENT DAMAGE TO THE BLADE AND BLADE PAINT, WRAP THE BLADE SHANKS IN SEVERAL LAYERS OF MASKING OR DUCT TAPE BEFORE REMOVING THE SPINNER DOME.

(1) Spinner dome removal

- (a) Remove the screws and washers that secure the spinner to the spinner bulkhead.
- (b) Remove the spinner dome.
- (c) Remove layers of masking or duct tape from each blade shank, if applicable.

WARNING 1: DURING ENGINE INSTALLATION OR REMOVAL, USING THE PROPELLER TO SUPPORT THE WEIGHT OF THE ENGINE IS NOT AUTHORIZED. UNAPPROVED INSTALLATION AND REMOVAL TECHNIQUES MAY CAUSE DAMAGE TO THE PROPELLER THAT MAY LEAD TO FAILURE AND RESULT IN AN AIRCRAFT ACCIDENT.

WARNING 2: DURING PROPELLER REMOVAL, AIRFRAME MANUFACTURER'S MANUALS AND PROCEDURES MUST BE FOLLOWED BECAUSE THEY MAY CONTAIN ISSUES VITAL TO AIRCRAFT SAFETY THAT ARE NOT CONTAINED IN THIS MANUAL OR IN THE HARTZELL PROPELLER OVERHAUL MANUALS.

CAUTION: OIL WILL FLOW OUT OF THE PROPELLER WHEN THE PISTON IS REMOVED. PUT A DRIP PAN UNDER THE PROPELLER TO CATCH THE EXCESS OIL.

- (2) Piston Removal (Refer to Figure 3-28.)
- (a) Remove the self-locking nut from each piston rod.
 - (b) Remove the washer from each piston rod.
 - (c) Loosen the set screw in each fork.
 - (d) Slide the piston away from the hub and to the low pitch position, until the piston rods clear the bulkhead.
 - (e) Rotate the piston and forks away from the clamp link screws.
 - (f) The piston ears and guide collar should have corresponding index numbers (1, 2, and 3) impression-stamped or marked with a felt-tipped pen. If they are not marked, number them with a felt-tipped pen.
NOTE: This will insure that the components are reassembled in their original location.
 - (g) Slide the piston off the cylinder and remove it from the propeller.
 - (h) To prevent the loss of the sleeve, fork, and high pitch stop washers, reinstall the self-locking nut, and washer on each piston rod.

- (i) The pitch change blocks should have index numbers (1, 2, and 3) marked with a felt-tipped pen to correspond to the numbers on the piston ears, forks, counterweights, and guide collar. If they are not marked, number them with a felt-tipped pen.

NOTE: This will insure that the components are reassembled in their original location.

- (j) Remove the pitch change block from each clamp linkscrew.
- (3) Remove the hub lock safety pin. Refer to Figure 3-31.
 - (4) Using tool BST-2910, completely loosen the shaft nut from the engine shaft threads.

NOTE: Because the shaft nut is pulling the propeller hub off the tapered rear cone, there will be significant initial resistance to the loosening of the shaft nut.

WARNING: MAKE SURE THE SLING IS RATED UP TO 800 POUNDS (363 KG) TO SUPPORT THE WEIGHT OF THE PROPELLER ASSEMBLY DURING REMOVAL.

- (5) Support the propeller assembly with a sling.

CAUTION: USE ADEQUATE PRECAUTIONS TO PROTECT THE PROPELLER ASSEMBLY FROM DAMAGE WHEN IT IS REMOVED FROM THE AIRCRAFT ENGINE AND WHEN IT IS STORED.

- (6) Using the support sling, slide the propeller from the engine splined shaft and lift the propeller from the engine.
- (7) Remove and discard the rear cone O-ring (Figure 3-35).
- (8) Remove the rear cone from the engine shaft (Figure 3-35).
- (9) Remove the rear spinner bulkhead from the engine shaft (Figure 3-35).
- (10) Put the propeller and associated parts on a suitable cart for transportation.

- Q. Removing the 20 Splined Propeller Models
HC-A2(MV,V)20-2 and HC-A3(MV,V)20-2()

Refer to Figures 3-36 and 3-37.

NOTE: If the propeller is equipped with an anti-ice or a de-ice system, follow the manufacturer's instructions for removing the components necessary for propeller removal.

CAUTION 1: INSTRUCTIONS AND PROCEDURES IN THIS SECTION MAY INVOLVE PROPELLER CRITICAL PARTS. REFER TO THE INTRODUCTION CHAPTER OF THIS MANUAL FOR INFORMATION ABOUT PROPELLER CRITICAL PARTS. REFER TO THE ILLUSTRATED PARTS LIST CHAPTER OF THE APPLICABLE OVERHAUL MANUAL(S) FOR THE IDENTIFICATION OF SPECIFIC PROPELLER CRITICAL PARTS.

CAUTION 2: TO PREVENT DAMAGE TO THE BLADE AND BLADE PAINT, WRAP THE BLADE SHANKS IN SEVERAL LAYERS OF MASKING OR DUCT TAPE BEFORE REMOVING THE SPINNER DOME.

- (1) Spinner dome removal
- (a) Remove the screws and washers that secure the spinner dome to the spinner bulkhead.
 - (b) Remove the spinner dome.

WARNING 1: DURING ENGINE INSTALLATION OR REMOVAL, USING THE PROPELLER TO SUPPORT THE WEIGHT OF THE ENGINE IS NOT AUTHORIZED. UNAPPROVED INSTALLATION AND REMOVAL TECHNIQUES MAY CAUSE DAMAGE TO THE PROPELLER THAT MAY LEAD TO FAILURE AND RESULT IN AN AIRCRAFT ACCIDENT.

WARNING 2: DURING PROPELLER REMOVAL, AIRFRAME MANUFACTURER'S MANUALS AND PROCEDURES MUST BE FOLLOWED BECAUSE THEY MAY CONTAIN ISSUES VITAL TO AIRCRAFT SAFETY THAT ARE NOT CONTAINED IN THIS MANUAL OR IN THE HARTZELL PROPELLER OVERHAUL MANUALS.

WARNING 3: FOR SAFETY REASONS, THE PROPELLER MUST BE PUT IN THE FEATHER POSITION BEFORE IT IS REMOVED FROM THE AIRCRAFT.

- (2) Routine propeller engine shutdown will engage the start lock units, preventing the propeller from feathering. For purposes of propeller removal, the propeller should be placed in feather position during engine shutdown. If this was not accomplished, then the propeller may be feathered as follows:

CAUTION: DO NOT PUT THE PADDED BAR IN THE AREA OF THE DE-ICE BOOT WHEN APPLYING TORQUE TO A BLADE ASSEMBLY. PUT THE BAR IN THE THICKEST AREA OF THE BLADE, JUST OUTBOARD OF THE DE-ICE BOOT. USE ONE BLADE PADDLE PER BLADE.

- (a) Rotate the blades simultaneously to a slightly lower pitch to disengage the start lock plates from the start lock units.
- (b) Retract the start lock pins and hold them in place with a heavy wire inserted through the hole of each start lock housing.
- (c) Slowly and carefully allow the blades to rotate to high/feather pitch.

- (3) Piston removal (Refer to figure 3-28)
 - (a) Remove the piston nut.
 - (b) Remove the safety wire from the link pin units.
 - (c) Remove the safety screws from each link pin unit.
 - (d) Remove each link pin unit.
 - (e) The piston ears and guide collar should have corresponding index numbers (1 and 2 for a 2-blade propeller; 1, 2, and 3 for a 3-blade propeller) impression-stamped or marked with a felt-tipped pen. If they are not marked, number them with a felt-tipped pen.

NOTE: This will insure that the components are reassembled in their original location.
 - (f) Remove the socket head cap screw, jam nut, and washer from each piston guide rod.
 - (g) Slide the piston off the cylinder.
- (4) Feathering spring assembly removal: Refer to Figure 3-38.

WARNING: DO NOT FORCE THE FEATHERING SPRING TO RELEASE THE SPLIT RINGS IN THE CYLINDER. FORCING THE FEATHERING SPRING MAY CAUSE THE RELEASE OF THE SPLIT RING RETAINERS IN THE SPRING ASSEMBLY, RESULTING IN THE EXPLOSIVE RELEASE OF THE FEATHERING SPRINGS.

- (a) Remove the safety wire (if installed) from the ring retention plate screws.
- (b) Remove the ring retention plate screws.
- (c) Remove the front spring retainer split rings by first pushing the feathering spring assembly into the cylinder about 0.25 inch (6.35 mm), allowing the split rings to fall out of the groove in the piston.
- (d) Remove the feathering spring assembly from the cylinder.

(5) Remove the hub lock safety pin.

WARNING: MAKE SURE THE SLING IS RATED UP TO 800 POUNDS (363 KG) TO SUPPORT THE WEIGHT OF THE PROPELLER ASSEMBLY DURING REMOVAL.

(6) Support the propeller assembly with a sling.

(7) Completely loosen the shaft nut from the engine shaft threads.

NOTE: Because the shaft nut is pulling the propeller hub off the tapered rear cone, there will be significant resistance to the loosening of the shaft nut.

CAUTION: USE ADEQUATE PRECAUTIONS TO PROTECT THE PROPELLER ASSEMBLY FROM DAMAGE WHEN IT IS REMOVED FROM THE AIRCRAFT ENGINE AND WHEN IT IS STORED.

(8) Using the support sling, slide the propeller from the engine splined shaft and lift the propeller from the engine.

(9) Remove and discard the rear cone O-ring on the engine splined shaft (Figure 3-39).

(10) If necessary, remove the rear cone (Figure 3-39).

(11) If necessary, remove the rear spinner bulkhead.

(12) Put the propeller and associated parts on a suitable cart for transportation.

- R. Removing the 20 Splined Propeller Models
HC-A2(MV,V)20-3L and HC-A3(MV,V)20-3L

Refer to Figures 3-41 and 3-42.

NOTE: If the propeller is equipped with an anti-ice or a de-ice system, follow the manufacturer's instructions for removing the components necessary for propeller removal.

CAUTION: INSTRUCTIONS AND PROCEDURES IN THIS SECTION MAY INVOLVE PROPELLER CRITICAL PARTS. REFER TO THE INTRODUCTION CHAPTER OF THIS MANUAL FOR INFORMATION ABOUT PROPELLER CRITICAL PARTS. REFER TO THE ILLUSTRATED PARTS LIST CHAPTER OF THE APPLICABLE OVERHAUL MANUAL(S) FOR THE IDENTIFICATION OF SPECIFIC PROPELLER CRITICAL PARTS.

WARNING 1: DURING ENGINE INSTALLATION OR REMOVAL, USING THE PROPELLER TO SUPPORT THE WEIGHT OF THE ENGINE IS NOT AUTHORIZED. UNAPPROVED INSTALLATION AND REMOVAL TECHNIQUES MAY CAUSE DAMAGE TO THE PROPELLER THAT MAY LEAD TO FAILURE AND RESULT IN AN AIRCRAFT ACCIDENT.

WARNING 2: DURING PROPELLER REMOVAL, AIRFRAME MANUFACTURER'S MANUALS AND PROCEDURES MUST BE FOLLOWED BECAUSE THEY MAY CONTAIN ISSUES VITAL TO AIRCRAFT SAFETY THAT ARE NOT CONTAINED IN THIS MANUAL OR IN THE HARTZELL PROPELLER OVERHAUL MANUALS.

- (1) HC-A3(MV,V)20-3L propeller models
 - (a) Remove the elastic nut from the end of each beta rod.
 - (b) Remove the ring that connects all beta rods together.

- (c) From each beta rod, remove the check nut that was used to secure the ring in place

NOTE: One lock nut should still be installed on each beta rod. Do not remove the nut at this time.

- (2) Make sure the piston is located at the highest blade pitch attainable.

WARNING: WHEN THE PROPELLER IS REINSTALLED, THE PROPELLER BLADE LOW PITCH ANGLE MUST BE MAINTAINED.

CAUTION: TO REESTABLISH THE LOCATION OF LOW PITCH WHEN THE PROPELLER IS REASSEMBLED, A PRECISE LOCATION OF THE LOW PITCH SELF-LOCKING NUT MUST BE ESTABLISHED. MEASUREMENT WITH A RULER IS NOT SUFFICIENT.

- (3) Using a dial caliper, measure the distance from the inboard surface of each self-locking low pitch nut to the end of the corresponding beta rod.
- (4) Using a separate information tag for each low pitch nut measurement, write the distance measured from the inboard surface of the self-locking low pitch nut to the end of the beta rod.
- (5) Securely attach each information tag to its corresponding beta return spring on the beta rod.
- (6) Remove the spacer and self-locking low pitch nut from each beta rod.
- (7) Piston removal (Refer to figure 3-28)
 - (a) Remove the piston nut.
 - (b) Remove the safety wire from the link pin units.
 - (c) Remove the safety screws from each link pin unit.
 - (d) Remove each link pin unit.

- (e) The piston ears and guide collar should have corresponding index numbers (1 and 2 for a 2-blade propeller; 1, 2, and 3 for a 3-blade propeller impression-stamped or marked with a felt-tipped pen. If they are not marked, number them with a felt-tipped pen.

NOTE: This will make sure that the components are reassembled in their original location.

- (f) Slide the piston off the cylinder.
- (8) Feathering spring assembly removal:
Refer to Figure 3-38.

WARNING: DO NOT FORCE THE FEATHERING SPRING TO RELEASE THE SPLIT RINGS IN THE CYLINDER. FORCING THE FEATHERING SPRING MAY CAUSE THE RELEASE OF THE SPLIT RING RETAINERS IN THE SPRING ASSEMBLY, RESULTING IN THE EXPLOSIVE RELEASE OF THE FEATHERING SPRINGS.

- (a) Remove the safety wire (if installed) from the feathering stop screws.
- (b) Remove the two screws from each of the two feathering stops on the front spring retainer.
- (c) Remove the feathering stops.
- (d) Remove the front spring retainer split rings by first pushing the feathering spring assembly into the cylinder about 0.25 inch (6.35 mm), allowing the split rings to fall out of the groove in the piston.
- (e) Remove the feathering spring assembly from the cylinder.
- (9) Remove the shaft nut lock.

WARNING: MAKE SURE THE SLING IS RATED UP TO 800 POUNDS (363 KG.) TO SUPPORT THE WEIGHT OF THE PROPELLER ASSEMBLY DURING REMOVAL.

- (10) Support the propeller assembly with a sling.

- (11) Using tool BST-2910, completely loosen the hub nut from the engine shaft threads.

NOTE: Because the shaft nut is pulling the propeller hub off the tapered rear cone, there will be significant initial resistance to the loosening of the shaft nut.

CAUTION: USE ADEQUATE PRECAUTIONS TO PROTECT THE PROPELLER ASSEMBLY FROM DAMAGE WHEN IT IS REMOVED FROM THE AIRCRAFT ENGINE AND WHEN IT IS STORED.

- (12) Using the support sling, slide the propeller from the engine splined shaft and lift the propeller from the engine.

- (13) Remove and discard the rear cone O-ring. Refer to Figure 3-43.

- (14) Remove the rear cone. Refer to Figure 3-43.

- (15) Put the propeller and associated parts on a suitable cart for transportation.

(This page is intentionally blank.)

CONTENTS

1. Operational Tests.....	4-3
A. Initial Run-Up.....	4-3
B. Static RPM Check.....	4-4
C. Post-Run Check.....	4-4
2. Propeller Ice Protection Systems.....	4-5
A. Electric De-Ice System.....	4-5
B. Anti-Ice System.....	4-5
3. Troubleshooting.....	4-5
A. Incorrect Maximum RPM (on ground).....	4-5
B. Hunting and Surging.....	4-7
C. Engine Speed Varies with Airspeed.....	4-8
D. Loss of Propeller Control - ()HC-A3()()-4() and HC-A2(MV,V)L-6F propeller models:.....	4-9
E. Loss of propeller Control - ()HC-A()()()-1(), -2(), -3(), and -5() propeller models:.....	4-10
F. Failure to Feather or Feathers Slowly - ()HC-A()()()-2() and ()HC-A()()()-5() propeller models only:.....	4-11
G. Failure to Unfeather - ()HC-A()()()-2() and ()HC-A()()()-5() propeller models only:.....	4-11
H. Start Locks (Anti-Feather Latches) Fail to Engage on Shutdown - ()HC-A()()()-2, and -5 propeller models only:.....	4-12
I. Vibration.....	4-13
J. Propeller Overspeed.....	4-14
K. Propeller Underspeed.....	4-14
L. Oil or Grease Leakage.....	4-15

(This page is intentionally blank.)

1. Operational Tests

Following propeller installation, and before flight, the propeller hydraulic system must be purged of air and proper operation verified.

CAUTION: INSTRUCTIONS AND PROCEDURES IN THIS SECTION MAY INVOLVE PROPELLER CRITICAL PARTS. REFER TO THE INTRODUCTION CHAPTER OF THIS MANUAL FOR INFORMATION ABOUT PROPELLER CRITICAL PARTS. REFER TO THE ILLUSTRATED PARTS LIST CHAPTER OF THE APPLICABLE OVERHAUL MANUAL(S) FOR THE IDENTIFICATION OF SPECIFIC PROPELLER CRITICAL PARTS.

A. Initial Run-Up

- (1) Perform engine start and warm-up per the Pilot's Operating Handbook (POH).
- (2) Cycle the propeller control throughout its operating pitch range from low to high (or as directed by the POH).
- (3) Repeat this procedure at least three times to purge air from the propeller hydraulic system and to introduce warmed oil to the cylinder.

NOTE: Pitch change response on the first operation from low to high blade angle may be slow, but should speed up on the second and third cycles.

- (4) Verify proper operation from low pitch to high pitch and throughout operating range.
- (5) Shut down the engine in accordance with the POH.

NOTE: Air trapped in the propeller hydraulic system will cause the pitch control to be imprecise and may result in propeller surging.

B. Static RPM Check

NOTE: This operational check should be performed after installation, maintenance, or propeller adjustment.

CAUTION: A CALIBRATED TACHOMETER MUST BE USED TO MAKE SURE OF THE ACCURACY OF THE RPM CHECK.

- (1) Set the brakes and chock the aircraft or tie aircraft down.
- (2) Back the governor Maximum RPM Stop out one turn.
- (3) Start the engine.
- (4) Advance the propeller control lever to MAX (max RPM), then retard the control lever one inch (25.4 mm).
- (5) SLOWLY advance the throttle to maximum manifold pressure.
- (6) Slowly advance the propeller control lever until the engine speed stabilizes.
 - (a) If engine speed stabilizes at the maximum RPM specified by the TC or STC holder, then the low pitch stop is set correctly.
 - (b) If engine speed stabilizes above or below the rated RPM, the low pitch stop may require adjustment. Refer to the Troubleshooting section of this chapter.
- (7) Stop the engine.
- (8) Return the governor Maximum RPM Stop to the original position, or adjust the governor to the rated RPM with the Maximum RPM Stop screw.

WARNING: REFER TO THE AIRCRAFT MAINTENANCE MANUAL FOR ADDITIONAL PROCEDURES THAT MAY BE REQUIRED AFTER PROPELLER INSTALLATION.

C. Post-Run Check

After engine shutdown, check the propeller for signs of engine oil leakage.

2. Propeller Ice Protection Systems**A. Electric De-Ice System**

- (1) Consult the Pilot Operating Handbook (including all supplements) regarding flight into conditions of known icing. The aircraft may not be certificated for flight in known icing conditions, even though propeller de-ice equipment is installed.
- (2) Refer to the Anti-Ice and De-Ice Systems chapter of this manual for functional tests of the de-ice system.

B. Anti-Ice System

- (1) Consult the Pilot Operating Handbook (including all supplements) regarding flight into conditions of known icing. The aircraft may not be certificated for flight in known icing conditions, even though propeller anti-ice equipment is installed.
- (2) Refer to the Anti-Ice and De-Ice Systems chapter of this manual for functional tests of the anti-ice system.

3. Troubleshooting

CAUTION: INSTRUCTIONS AND PROCEDURES IN THIS SECTION MAY INVOLVE PROPELLER CRITICAL PARTS. REFER TO THE INTRODUCTION CHAPTER OF THIS MANUAL FOR INFORMATION ABOUT PROPELLER CRITICAL PARTS. REFER TO THE ILLUSTRATED PARTS LIST CHAPTER OF THE APPLICABLE OVERHAUL MANUAL(S) FOR THE IDENTIFICATION OF SPECIFIC PROPELLER CRITICAL PARTS.

A. Incorrect Maximum RPM (on ground)

- (1) Incorrect maximum RPM on the ground may be caused by low engine power, and incorrect governor maximum RPM stop setting, or an incorrect propeller low pitch stop.

CAUTION: A CALIBRATED TACHOMETER MUST BE USED TO MAKE SURE OF THE ACCURACY OF THE RPM CHECK.

- (2) Perform a check as described in the Maximum RPM Check (On Ground) procedure in the Maintenance Practices chapter of this manual.

NOTE: Incorrect RPM and associated checks apply to governing propellers only and do not apply to ground adjustable propeller model HA-A2(MV,V)20-1B

- (3) Maximum RPM is Low

(a) If engine power is low:

- 1 Follow the aircraft POH and/or AMM recommended checks to determine if the engine power is low.
- 2 If the engine power is low, refer to a certified propeller repair station with the appropriate rating or the engine manufacturer.

(b) If the engine power is within acceptable limits, examine the maximum RPM stop setting of the governor.

- (4) If maximum RPM is High:

(a) Engine power is high.

- 1 Follow the aircraft POH and/or AMM recommended engine checks to determine if the engine power is high.
- 2 If the engine power is high, refer to a certified propeller repair station with the appropriate rating or to the engine manufacturer.

(b) If the engine power is within acceptable limits, examine the maximum RPM stop setting of the governor.

- (5) Governor maximum RPM stop setting

- (a) When RPM is high, both the governor maximum RPM stop and the propeller low pitch blade angle are improperly adjusted.
- (b) Adjust the governor maximum RPM stop to obtain the rated maximum RPM.

- (c) For low pitch setting verification, refer to the procedures in the Maintenance Practices chapter of this manual.

B. Hunting and Surging

Hunting is characterized by a cyclic variation in engine speed above and below desired speed. Surging is characterized by a large increase/decrease in engine speed, followed by a return to set speed after one or two occurrences.

NOTE: Propeller model HA-A2(MV,V)20-1B only does not change blade pitch in flight; therefore, it does not hunt or surge as a result of propeller pitch control issues. Only a cyclic variation in engine power would result in a cyclic variation in engine speed.

- (1) If propeller is hunting, a certified propeller repair station with the appropriate rating should check:
 - (a) Governor
 - (b) Fuel control
 - (c) Synchrophaser, or synchronizer.
- (2) If propeller is surging:
 - (a) Perform the steps 1.A.(1)-(5) under Operational Tests section in this chapter to release trapped air from the propeller. If surging reoccurs it is most likely due to a faulty governor.
 - (b) Hunting and/or surging may also be caused by friction or binding within the governor control, or internal propeller corrosion, which causes the propeller to react slower to governor commands.

NOTE: The propeller must be tested on a test bench at a propeller repair station to isolate these faults.

- (c) Hunting and/or surging on reversing propeller models ()HC-A()()-2() and ()HC-A()()-5 when operating at or near low pitch may be caused by excessive side clearance between the beta ring and the carbon block assembly. Refer to the Carbon Block Assemblies section in the Maintenance Practices chapter of this manual.

C. Engine Speed Varies with Airspeed

NOTE: This section does not apply to propeller model HA-A2MV20-1B, since it is not constant speed and does not change blade pitch in flight. For this model, engine speed will increase with increasing airspeed and will decrease with decreasing airspeed.

- (1) Constant speed propeller models ()HC-A()()-1(), -2(), -3(), -4(), -5(), and -6() will experience some small variances in engine speed that are normal and are no cause for concern.
- (2) Increase in engine speed while descending or increasing airspeed:
 - (a) ()HC-A3()()-4(), and HC-A2(MV,V)L-6F propeller models:
 - 1 Governor is not increasing oil volume in the propeller.
 - 2 Engine oil transfer bearing is leaking excessively.
 - 3 Excessive friction in the blade bearings, in the pitch change mechanism, or in the misalignment between the guide collar and the piston rods.
 - (b) ()HC-A()()-1(), -2(), -3() and -5() propeller models:
 - 1 Governor is not reducing oil volume in the propeller.
 - 2 Excessive friction in the blade bearings or the pitch change mechanism.
 - 3 Excessive friction in the misalignment between the guide collar and the piston rods - ()HC-A()()-1(), ()HC-A3()()-2(), HC-A2(MV,V)20-2, and HC-A3(MV,V)F-5A(L) propellers only.

- (3) Decrease in engine speed while increasing airspeed:
- (a) ()HC-A3()(-4() and HC-A2(MV,V)L-6F propeller models:
 - 1 Governor pilot valve is stuck and is excessively increasing oil volume.
 - (b) ()HC-A()(-1(), -2(), -3(), and -5() propeller models:
 - 1 Governor pilot valve is stuck and is excessively decreasing oil volume.
 - 2 Feathering command is engaged on the propeller pitch control - ()HC-A()(-2, -5 propeller models only.
- (4) Increase in engine speed while decreasing airspeed:
- (a) ()HC-A3()(-4() and HC-A2(MV,V)L-6F propeller models:
 - 1 Governor pilot valve is stuck and is excessively decreasing oil volume in the propeller.
 - (b) ()HC-A()(-1(), -2(), -3(), and -5() propeller models:
 - 1 Governor pilot valve is stuck and is excessively increasing oil volume.
- (5) Decrease in engine speed while decreasing airspeed:
- (a) ()HC-A3()(-4() and HC-A2(MV,V)L-6F propeller models:
 - 1 Governor is not reducing oil volume in the propeller.
 - 2 Excessive friction in the blade bearings or pitch change mechanism.
 - (b) ()HC-A()(-1(), -2(), -3(), and -5() propeller models:
 - 1 Governor is not increasing oil volume in the propeller.
 - 2 Engine oil transfer bearing is leaking excessively.
 - 3 Excessive friction in the blade bearings or the pitch change mechanism.
- D. Loss of Propeller Control - ()HC-A3()(-4() and HC-A2(MV,V)L-6F propeller models:

- (1) Propeller goes to uncommanded low pitch (high RPM)
 - (a) Loss of oil pressure - check:
 - 1 Governor pressure relief valve for proper operation.
 - 2 Governor pilot valve sticking.
 - 3 Governor drive for damage.
 - 4 Adequate engine oil supply.
 - 5 Engine oil transfer bearing for excessive leakage.
 - (2) Propeller goes to uncommanded high pitch (low RPM)
 - (a) Governor pilot valve sticking.
 - (3) RPM increases with power and airspeed, propeller RPM control has little or no effect.
 - (a) Excessive friction in blade bearings or pitch change mechanism.
 - (b) Misalignment between the guide collar and piston rods.
 - (c) Engine oil transfer bearing is leaking excessively.
 - (d) Governor is not increasing oil volume in the propeller.
- E. Loss of propeller Control - ()HC-A()()-1(), -2(), -3(), and -5() propeller models:
- (1) Propeller goes to uncommanded high pitch (or feather)
 - (a) Loss of propeller oil pressure - check:
 - 1 Governor pressure relief valve for proper operation.
 - 2 Governor drive for damage.
 - 3 Adequate engine oil supply.
 - 4 Engine oil transfer bearing for excessive leakage.
 - (b) Start Lock not engaging - ()HC-A()()-2() and ()HC-A()()-5() propeller models only
 - (2) Propeller goes to uncommanded low pitch (high RPM)
 - (a) governor pilot valve sticking.

- (3) RPM increases with power and airspeed. Propeller RPM control has little or no effect.
 - (a) Excessive friction in blade bearings or pitch change mechanism.
 - (b) Excessive friction in misalignment between the guide collar and the piston rods - ()HC-A()()-1(), ()HC-A3()-2(), HC-A2(MV,V)20-2, and HC-A3(MV,V)F-5A(L) propeller models only.
 - (c) Broken spring (applies to ()HC-A()()-2(), ()HC-A()()-3(), and ()HC-A()()-5() propeller models.)
 - (d) Governor is not reducing oil volume in the propeller.
- F. Failure to Feather or Feathers Slowly - ()HC-A()()-2() and ()HC-A()()-5() propeller models only:
 - (1) Broken feathering spring.
 - (2) Check for proper function and rigging of the propeller/governor control linkage.
 - (3) Check governor drain function.
 - (4) Propeller must be checked for misadjustment or internal corrosion (usually in blade bearings or pitch change mechanism) that results in excessive friction. This must be accomplished at a certified propeller repair station with the appropriate rating.
- G. Failure to Unfeather - ()HC-A()()-2() and ()HC-A()()-5() propeller models only:
 - (1) Check for proper function and rigging of the propeller control linkage to the governor.
 - (2) Check governor function.
 - (3) Check for excessive oil leakage at the engine oil transfer bearing.
 - (4) Propeller must be checked for misadjustment or internal corrosion (usually in blade bearings or pitch change mechanism) that results in excessive friction. This must be accomplished at a certified propeller repair station with the appropriate rating.

H. Start Locks (Anti-Feather Latches) Fail to Engage on Shutdown - ()HC-A()()-2, and -5 propeller models only:

(1) Propeller was feathered before shutdown.

CAUTION: DO NOT PLACE THE BLADE PADDLE IN THE AREA OF THE DE-ICE BOOT WHEN APPLYING TORQUE TO A BLADE ASSEMBLY. PLACE THE BLADE PADDLE IN THE THICKEST AREA OF THE BLADE, JUST OUTSIDE OF THE DE-ICE BOOT. USE ONE BLADE PADDLE PER BLADE.

(a) Using the blade paddles, simultaneously rotate the blades toward low pitch until the auto high pitch stop pins engage a clamp mounted stop plate.

(2) Shutdown occurred at high RPM with the propeller control set for coarse blade angle or low RPM.

CAUTION: DO NOT PLACE THE BLADE PADDLE IN THE AREA OF THE DE-ICE BOOT WHEN APPLYING TORQUE TO A BLADE ASSEMBLY. PLACE THE BLADE PADDLE IN THE THICKEST AREA OF THE BLADE, JUST OUTSIDE OF THE DE-ICE BOOT. USE ONE BLADE PADDLE PER BLADE.

(a) Using the blade paddles, simultaneously rotate the blades toward low pitch until the start lock pins engage a clamp mounted stop plate.

(3) Excessive engine oil transfer bearing leakage.

Refer to a certified propeller repair station with the appropriate rating.

(4) Excessive governor pump leakage.

Refer to a certified propeller repair station with the appropriate rating.

(5) Broken start locks.

Refer to a certified propeller repair station with the appropriate rating.

I. Vibration

CAUTION: ANY VIBRATION THAT CAN BE DESCRIBED AS APPEARING SUDDENLY, OR IS ACCOMPANIED BY UNEXPLAINED GREASE LEAKAGE, SHOULD BE INVESTIGATED IMMEDIATELY, BEFORE FURTHER FLIGHT.

NOTE: Vibration problems due to propeller system imbalance are normally felt throughout the RPM range, with the intensity of vibration increasing with RPM. Vibration problems that occur in a narrow RPM range are a symptom of resonance, which is potentially harmful to the propeller. Avoid operation until the propeller can be checked by an airworthiness agency approved repair station.

(1) Check:

- (a) Control surfaces, cowl flaps, exhaust system, landing gear doors, etc. for excessive play, which may be causing vibration unrelated to the propeller.
- (b) Secure attachment of engine mounted hardware.
- (c) Engine mount wear.
- (d) Uneven lubrication of propeller.
- (e) Proper engine/propeller flange mating.
- (f) Blade track. (For procedure, see the Inspection and Check chapter of this manual.)
- (g) Blade angles: Blade angle must be within 0.2 degree from blade to blade.
- (h) Spinner for cracks, improper installation, or "wobble" during operation.
- (i) Static balance.
- (j) Airfoil profile identical between blades (after overhaul or rework for nicks - verify at propeller repair station).
- (k) Hub, blade or blade clamp for damage or cracking.
- (l) Grease or oil leakage from a seemingly solid surface of the hub, blade clamp or blade.

(m) Blade deformation.

NOTE: Dynamic balancing is recommended after installing or performing maintenance on a propeller. While normally an optional task, it may be required by the engine or airframe manufacturer to make certain the propeller/engine combination is balanced within close tolerances before operation. Refer to the engine or airframe manuals, and the Maintenance Practices chapter of this manual.

J. Propeller Overspeed

(1) Check:

- (a) Tachometer error.
- (b) Low pitch stop adjustment.
- (c) Governor maximum RPM set too high.
- (d) Loss of oil pressure - ()HC-A3()()-4() and HC-A2(MV,V)L-6F
 - 1 Governor failure
 - 2 Excessive leakage in the governor oil supply to the propeller.
- (e) Broken spring causes momentary overspeed - ()HC-A()()-2(), ()HC-A()()-3(), and ()HC-A()()-5() propeller models.
- (f) Governor pilot valve jammed, supplying high pressure only - ()HC-A()()-1(), -2(), -3(), and -5() propeller models.

K. Propeller Underspeed

(1) Check:

- (a) Tachometer error.
- (b) Excessive transfer bearing leakage - ()HC-A()()-1(), -2(), -3(), and -5() propeller models.
- (c) Governor oil pressure low - ()HC-A()()-1(), -2(), -3(), and -5() propeller models.
- (d) Governor oil passage clogged.
- (e) Governor pilot valve jammed - ()HC-A()()-1(), -2(), -3(), and -5() propeller models.

L. Oil or Grease Leakage

CAUTION: GREASE LEAKAGE THAT CAN BE DESCRIBED AS EXCESSIVE AND APPEARING SUDDENLY, ESPECIALLY WHEN ACCOMPANIED BY VIBRATION, SHOULD BE INVESTIGATED IMMEDIATELY BEFORE FURTHER FLIGHT.

(1) Grease Leakage - Probable Cause:

NOTE: The blade clamp is the only source of grease leakage.

(a) Improperly torqued or loose lubrication fitting.
Tighten the fitting.

(b) Defective lubrication fitting.
Replace the fitting.

(c) Incorrect O-ring between the blade clamp and the propeller hub.

Refer to a certified propeller repair station with the appropriate rating for replacement of the O-ring.

(d) Grease leaks past the blade clamp seal gaskets.
Replace the gaskets.

(e) Grease leaks from between the blade clamp and the blade.

Refer to a certified propeller repair station with the appropriate rating for replacement of sealant.

(f) Grease leaks from the clamp in a static condition when the blade is pointed up. - Improper application of silicone sealant on the clamp radius of the bearing-to-clamp interface.

Refer to a certified propeller repair station with the appropriate rating for reapplication of silicone sealant.

- (2) Oil Leakage - Probable Cause
 - (a) Faulty O-ring seal between the hub and the cylinder.
 - (b) Faulty O-ring seal between the piston and the cylinder.
 - (c) Displaced felt seal between the piston and the cylinder
 - (d) Faulty O-ring between the propeller hub and the engine flange.
 - (e) Faulty O-ring between the piston and the pitch change rod.
- (3) Beta System Oil Leakage - Probable Cause
 - (a) Governor leaks oil. Refer to a certified propeller repair station with the appropriate rating.
 - (b) Faulty gasket between the governor and beta valve, or the beta valve and the engine. Replace the gasket.
 - (c) Faulty O-rings between the beta valve body and the beta valve spool. Refer to a certified propeller repair station with the appropriate rating for replacement.

CONTENTS

1. Pre-Flight Checks	5-3
2. Operational Checks	5-5
3. Required Periodic Inspections and Maintenance	5-6
A. Periodic Inspection	5-6
B. Periodic Maintenance	5-7
C. Airworthiness Limitations	5-7
D. Overhaul Periods	5-8
4. Inspection Procedures	5-9
A. Blade Damage	5-9
B. Grease or Oil Leakage	5-9
C. Vibration	5-11
D. Tachometer Inspection	5-13
E. Blade Track	5-15
F. Loose Blades	5-15
G. Corrosion	5-16
H. Spinner Damage	5-16
I. Electric De-Ice System	5-16
J. Anti-Ice System	5-16
5. Special Inspections	5-19
A. Overspeed	5-19
B. Lightning Strike	5-20
C. Foreign Object Strike/Ground Strike	5-22
D. Fire Damage or Heat Damage	5-24
6. Long Term Storage	5-24

FIGURES

Checking Blade Track	Figure 5-1	5-14
Blade Play	Figure 5-2	5-14
Reciprocating Engine Overspeed Limits	Figure 5-3	5-18

(This page is intentionally blank.)

1. Pre-Flight Checks

CAUTION: INSTRUCTIONS AND PROCEDURES IN THIS SECTION MAY INVOLVE PROPELLER CRITICAL PARTS. REFER TO THE INTRODUCTION CHAPTER OF THIS MANUAL FOR INFORMATION ABOUT PROPELLER CRITICAL PARTS. REFER TO THE ILLUSTRATED PARTS LIST CHAPTER OF THE APPLICABLE OVERHAUL MANUAL(S) FOR THE IDENTIFICATION OF SPECIFIC PROPELLER CRITICAL PARTS.

Follow propeller preflight inspection procedures as specified in the Pilot Operating Handbook (P.O.H.) or this manual. In addition, perform the following inspections:

A. Blades

- (1) Visually inspect the entire blade (lead, trail, face, and camber sides) for nicks, gouges, erosion and cracks. Repair before further flight. Refer to the Maintenance Practices chapter of this manual, for blade repair information. Normal blade lead edge erosion (sand-blasted appearance) is acceptable, and does not require removal before further flight.
- (2) Visually inspect the blades for lightning strike. Refer to the Lightning Strike Damage section in this chapter for a description of damage.

B. Inspect the spinner and visible blade retention components for damage or cracks. Repair or replace components as required before further flight.

C. Check for loose/missing hardware. Retighten or reinstall as necessary.

WARNING: ABNORMAL GREASE LEAKAGE CAN BE AN INDICATION OF A FAILING PROPELLER BLADE OR BLADE RETENTION COMPONENT. AN IN-FLIGHT BLADE SEPARATION CAN RESULT IN A CATASTROPHIC AIRCRAFT ACCIDENT.

D. Inspect for grease and oil leakage and determine its source.

WARNING: ABNORMAL VIBRATION CAN BE AN INDICATION OF A FAILING PROPELLER BLADE OR BLADE RETENTION COMPONENT. AN IN-FLIGHT BLADE SEPARATION CAN RESULT IN A CATASTROPHIC AIRCRAFT ACCIDENT.

- E. Check the blades for radial play or movement of the blade tip (in and out, fore and aft, and end play). Refer to Loose Blades, in the Periodic Inspections section of this chapter, for blade play limits.
- F. Inspect de-ice boots (if installed) for damage. Refer to De-Ice Systems in the Anti-Ice and De-Ice Systems chapter of this manual, for inspection information.
- G. Refer to the Periodic Inspections section in this chapter for additional inspection information and possible corrections to any discrepancies discovered as a result of preflight checks.

2. Operational Checks

CAUTION: INSTRUCTIONS AND PROCEDURES IN THIS SECTION MAY INVOLVE PROPELLER CRITICAL PARTS. REFER TO THE INTRODUCTION CHAPTER OF THIS MANUAL FOR INFORMATION ABOUT PROPELLER CRITICAL PARTS. REFER TO THE ILLUSTRATED PARTS LIST CHAPTER OF THE APPLICABLE OVERHAUL MANUAL(S) FOR THE IDENTIFICATION OF SPECIFIC PROPELLER CRITICAL PARTS.

- A. Following propeller installation and before flight, perform initial run-up as outlined in Operational Tests in the Testing and Troubleshooting chapter of this manual.
- B. Check the propeller speed control and operation from reverse or low pitch to high pitch, using the procedure specified in the Pilot Operating Handbook (POH) for the aircraft.
 - (1) Perform all ground functional, feathering, and cycling checks with the minimum propeller RPM drop required to demonstrate function.
 - (2) A typical RPM drop is 300-500 RPM for feathering propellers and 100 to 300 RPM for non-feathering propellers.

WARNING: ABNORMAL VIBRATION CAN BE AN INDICATION OF A FAILING PROPELLER BLADE OR BLADE RETENTION COMPONENT. AN IN-FLIGHT BLADE SEPARATION MAY RESULT IN DEATH, SERIOUS BODILY INJURY, AND/OR SUBSTANTIAL PROPERTY DAMAGE.

- C. Check for any abnormal vibration during this run-up. If vibration occurs, shut the engine down, determine the cause, and correct it before further flight. Refer to the Vibration section in the Testing and Troubleshooting chapter of this manual.
- D. Refer to Periodic Inspections in this chapter for additional inspection information and possible corrections to any discrepancies discovered as a result of Pre-Flight Checks.
- E. Refer to the airframe manufacturer's manual for additional operational checks.

3. Required Periodic Inspection and Maintenance

CAUTION: INSTRUCTIONS AND PROCEDURES IN THIS SECTION MAY INVOLVE PROPELLER CRITICAL PARTS. REFER TO THE INTRODUCTION CHAPTER OF THIS MANUAL FOR INFORMATION ABOUT PROPELLER CRITICAL PARTS. REFER TO THE ILLUSTRATED PARTS LIST CHAPTER OF THE APPLICABLE OVERHAUL MANUAL(S) FOR THE IDENTIFICATION OF SPECIFIC PROPELLER CRITICAL PARTS.

Perform detailed inspection procedures at 100 hour intervals, not to exceed twelve (12) calendar months. Procedures involved in these inspections are detailed below.

A. Periodic Inspection

NOTE 1: Inspection and maintenance specified by an airframe manufacturer's maintenance program and approved by the applicable airworthiness agency may not coincide with the inspection time interval specified. In this situation the airframe manufacturer's schedule may be applied with the exception that the calendar limit for the inspection interval may not exceed (12) calendar months.

NOTE 2: Refer to Inspection Procedures in this chapter for additional inspection information and possible corrections to any discrepancies discovered as a result of the Periodic Inspection.

- (1) Remove the spinner.
- (2) Visually inspect the blades for nicks, gouges, and cracks. If any damage is discovered, refer to the Blade Repairs section in the Maintenance Practices chapter of this manual for additional information. A cracked blade must be referred to a certified propeller repair station with the appropriate rating.
- (3) Inspect all visible propeller parts for cracks, wear or unsafe conditions.
- (4) Check for oil and grease leaks. Refer to Oil and Grease Leakage in the Inspection Procedures section of this chapter.

- (5) Check the blade track. Refer to Blade Track in the Inspection Procedures section of this chapter.
 - (6) Check the accuracy of the tachometer. Refer to Tachometer Inspection in the Inspection Procedures section of this chapter.
 - (7) Clean or replace the anti-ice system filter (if anti-ice system is installed).
 - (8) Make an entry in this log book verifying this inspection.
- B. Periodic Maintenance
- (1) Lubricate the propeller assembly. Refer to the Lubrication section in the Maintenances Practices chapter of this manual for intervals and procedures.
- C. Airworthiness Limitations
- (1) Certain components, as well as the entire propeller may have specific life limits established as part of the certification by the FAA. Such limits call for mandatory replacement of specified parts after a defined number of hours and/or cycles of use.
 - (2) Life limited component times may exist for the propeller models covered in this manual. Refer to the Airworthiness Limitations section of this manual.
 - (3) Operators are urged to keep informed of airworthiness information via Hartzell Service Bulletins and Service Letters, which are available from Hartzell distributors or from the Hartzell factory by subscription. Selected information is also available on Hartzell Propeller's website at www.hartzellprop.com.

D. Overhaul Periods

In flight, the propeller is constantly subjected to vibration from the engine and the airstream, as well as high centrifugal forces. The propeller is also subject to corrosion, wear, and general deterioration due to aging. Under these conditions, metal fatigue or mechanical failures can occur. To protect your safety and your investment, and to maximize the safe operating lifetime of your propeller, it is essential that a propeller be properly maintained and overhauled according to the recommended service procedures.

CAUTION 1: OVERHAUL PERIODS LISTED BELOW, ALTHOUGH CURRENT AT THE TIME OF PUBLICATION, ARE FOR REFERENCE PURPOSES ONLY. OVERHAUL PERIODS MAY BE INCREASED OR DECREASED AS A RESULT OF CONTINUING EVALUATION.

CAUTION 2: CHECK THE LATEST REVISION OF HARTZELL SERVICE LETTER 61() FOR THE MOST CURRENT INFORMATION.

(1) Hartzell "reciprocating" propellers installed on piston engine aircraft are to be overhauled at intervals as follows:

(a) Agricultural Aircraft -

Propeller models ()HC-A()V()-() - 1000 hours or 36 calendar months (whichever occurs first).

Propeller models ()HC-A()MV()-() - 2000 hours or 36 calendar months (whichever occurs first).

NOTE 1: Agricultural aircraft are defined as aircraft used as aerial applicators that expose the propeller to a relatively severe chemical/corrosive environment.

NOTE 2: Once the propeller is used on agricultural aircraft, the 36 month overhaul limit is to be maintained even if propeller is later installed on other category airplanes.

- (b) Aerobatic Aircraft - 1000 hours or 60 calendar months (whichever occurs first).

NOTE: Aerobatic aircraft are defined as certificated aerobatic category aircraft or other aircraft routinely exposed to aerobatic use.

- (c) All Other Aircraft -

Propeller models ()HC-A()V()-() - 1000 hours or 60 calendar months (whichever occurs first).

Propeller models ()HC-A()MV()-() - 2000 hours or 60 calendar months (whichever occurs first).

4. Inspection Procedures

CAUTION: INSTRUCTIONS AND PROCEDURES IN THIS SECTION MAY INVOLVE PROPELLER CRITICAL PARTS. REFER TO THE INTRODUCTION CHAPTER OF THIS MANUAL FOR INFORMATION ABOUT PROPELLER CRITICAL PARTS. REFER TO THE ILLUSTRATED PARTS LIST CHAPTER OF THE APPLICABLE OVERHAUL MANUAL(S) FOR THE IDENTIFICATION OF SPECIFIC PROPELLER CRITICAL PARTS.

The following inspections are made on a regular basis, either before flight, or if a problem is noted. Possible corrections to problems discovered during inspections, additional inspections, and limits are detailed in the following inspection procedures.

A. Blade Damage

Refer to Blade Repairs section in the Maintenance Practices chapter of this manual for information regarding blade damage.

B. Grease or Oil Leakage

NOTE: A new or newly overhauled propeller may leak slightly during the first several hours of operation. This leakage may be caused by the seating of seals and O-rings, and the slinging of lubricants used during assembly. Such leakage should cease within the first ten hours of operation.

Leakage that persists beyond the first ten hours of operation on a new or newly overhauled propeller, or occurs on a propeller that has been in service for some time will require repair. A determination should be made as to the source of the leak. The only leakage that is field repairable is the removal and replacement of the O-ring seal between the engine and propeller flange. All other leakage repairs should be referred to a certified propeller repair station with the appropriate rating. An instance of abnormal grease leakage should be inspected using the following procedure:

(1) Remove the spinner dome.

CAUTION: PERFORM A VISUAL INSPECTION WITHOUT CLEANING THE PARTS. A TIGHT CRACK IS OFTEN EVIDENT DUE TO TRACES OF GREASE EMANATING FROM THE CRACK. CLEANING CAN REMOVE SUCH EVIDENCE AND MAKE A CRACK VIRTUALLY IMPOSSIBLE TO SEE.

- (2) Perform a visual inspection of the hub, blade clamps and blades to locate the origin of leakage. If the origin of the grease leakage is determined to be a noncritical part, such as an O-ring, gasket or sealant, repairs can be accomplished during scheduled maintenance as long as flight safety is not compromised.
- (3) If cracks are suspected, perform additional inspections before further flight (by qualified personnel at a certified propeller repair station with the appropriate rating) to verify the condition. Such inspections typically include disassembly of the propeller followed by inspection of parts, using nondestructive methods in accordance with published procedures.
- (4) If cracks or failing components are found, these parts must be replaced before further flight. Report such occurrences to airworthiness authorities and to Hartzell Propeller Inc. Product Support.

C. Vibration

Instances of abnormal vibration should be investigated immediately. If the cause of the vibration is not readily apparent, the propeller may be inspected following the procedure below:

NOTE: It may sometimes be difficult to readily identify the cause of abnormal vibration. Vibration may originate in the engine, propeller, or airframe. Troubleshooting procedures typically begin with an investigation of the engine. Airframe components, such as engine mounts or loose landing gear doors, can also be the source of vibration. When investigating an abnormal vibration, the possibility of a failing blade or blade retention component should be considered as a potential source of the problem.

- (1) Perform troubleshooting and evaluation of possible sources of vibration in accordance with engine or airframe manufacturer's instructions.
- (2) Refer to the Vibration section in the Testing and Troubleshooting chapter of this manual. Perform the checks to determine possible cause of the vibration. If no cause is found, then consider that the origin of the problem could be the propeller and proceed with steps 4.C.(3) through 4.C.(8) in this chapter.
- (3) Remove the spinner dome.
- (4) Perform a visual inspection for cracks in the hub, blade clamps and blades.

NOTE: A crack may be readily visible or may be indicated by grease leaking from a seemingly solid surface.

- (5) If cracks are suspected, additional inspections must be performed before further flight. These inspections must be performed by qualified personnel at an Airworthiness agency approved propeller repair station to verify the condition. Such inspections typically include disassembly of the propeller followed by inspection of parts, using nondestructive methods in accordance with published procedures.

- (6) Check the blades and compare blade to blade differences:
 - (a) Inspect the propeller blades for unusual looseness or movement. Refer to Loose Blades section of this chapter.
 - (b) Check blade track. Refer to Blade Track section of this chapter.

CAUTION: DO NOT USE BLADE PADDLES TO TURN BLADES.

- (c) Manually (by hand) attempt to turn the blades (change pitch).
 - (d) Visually check for damaged blades.
- (7) If abnormal blade conditions or damage are found, perform additional inspections (by qualified personnel at an Airworthiness agency approved propeller repair station) to evaluate the condition. Refer to Blade Repairs section in Maintenance Practices chapter of this manual.
- (8) If cracks or failing components are found, these parts must be replaced before further flight. Report such occurrences to airworthiness authorities and Hartzell Propeller Inc. Product Support.

D. Tachometer Inspection

NOTE: An Airworthiness agency approved propeller repair station may also be able to perform a tachometer inspection.

WARNING: OPERATION WITH AN INACCURATE MAY RESULT IN OPERATION AT A RESTRICTED RPM AND DAMAGING HIGH STRESSES. BLADE LIFE WILL BE SHORTENED AND COULD RESULT IN CATASTROPHIC FAILURE.

- (1) Accuracy of the engine tachometer should be verified at 100 hour intervals or at annual inspection, whichever occurs first.
- (2) Hartzell Propeller Inc. recommends using a tachometer that is accurate within ± 10 RPM, has NIST calibration (traceable), and has an appropriate calibration schedule.

APS6155

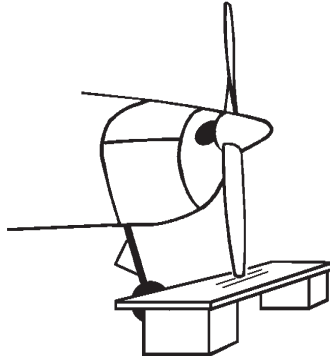

Checking Blade Track
Figure 5-1

APS6163

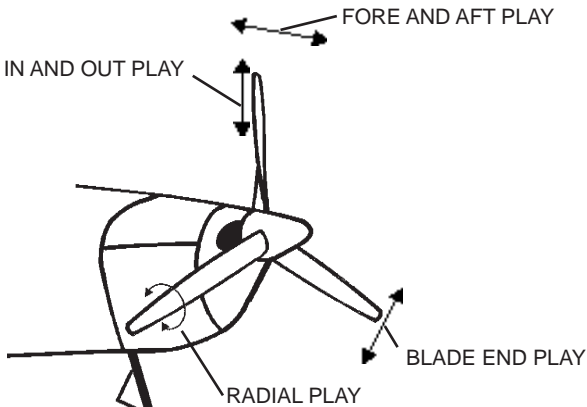

Blade Play
Figure 5-2

E. Blade Track

(1) Check the blade track as follows:

- (a) Chock the aircraft wheels securely.
- (b) Refer to Figure 5-1. Place a fixed reference point beneath the propeller, within 0.25 inch (6 mm) of the lowest point of the propeller arc.

NOTE: This reference point may be a flat board with a sheet of paper attached to it. The board may then be blocked up to within 0.25 inch (6.0 mm) of the propeller arc.

WARNING: MAKE SURE THE ENGINE MAGNETO IS GROUNDED (OFF) BEFORE ROTATING THE PROPELLER.

- (c) Rotate the propeller by hand (the opposite direction of normal rotation) until a blade points directly at the paper. Mark the position of the blade tip in relation to the paper.
- (d) Repeat this procedure with the remaining blades.
- (e) Tracking tolerance is ± 0.062 inch (1.57 mm) or 0.125 inch (3.17 mm) total.

(2) Possible Correction

- (a) Remove foreign matter from the propeller mounting flange.
- (b) If no foreign matter is present, refer to a certified propeller repair station with the appropriate rating

F. Loose Blades

Refer to Figure 5-2. Limits for blade looseness are as follows:

End Play	± 0.06 inch (1.5 mm)
Fore & Aft Movement	± 0.06 inch (1.5 mm)
In and Out Movement	0.032 inch (0.81 mm)
Radial Play (pitch change)	± 0.5 degree (1 degree total)

Blade movement beyond these limits should be referred to a certified propeller repair station with the appropriate rating.

G. Corrosion

WARNING: REWORK THAT INVOLVES COLD WORKING THE METAL, RESULTING IN CONCEALMENT OF A DAMAGED AREA IS NOT PERMITTED.

Light corrosion on blades may be removed by qualified personnel in accordance with the Blade Repairs section in the Maintenance Practices chapter of this manual.

Heavy corrosion that results in severe pitting must be referred to a certified propeller repair station with the appropriate rating.

H. Spinner Damage

Inspect the spinner for cracks, missing hardware, or other damage. Refer to a certified propeller repair station with the appropriate rating for spinner damage acceptance and repair information. There are no Hartzell Propeller Inc. approved field repairs to metal spinners. Contact the local airworthiness authority for repair approval.

I. Electric De-ice System

Refer to the Anti-Ice and De-ice Systems chapter of this manual for inspection procedures.

J. Anti-ice System

Refer to the Anti-Ice and De-ice Systems chapter of this manual for inspection procedures.

(This page is intentionally blank.)

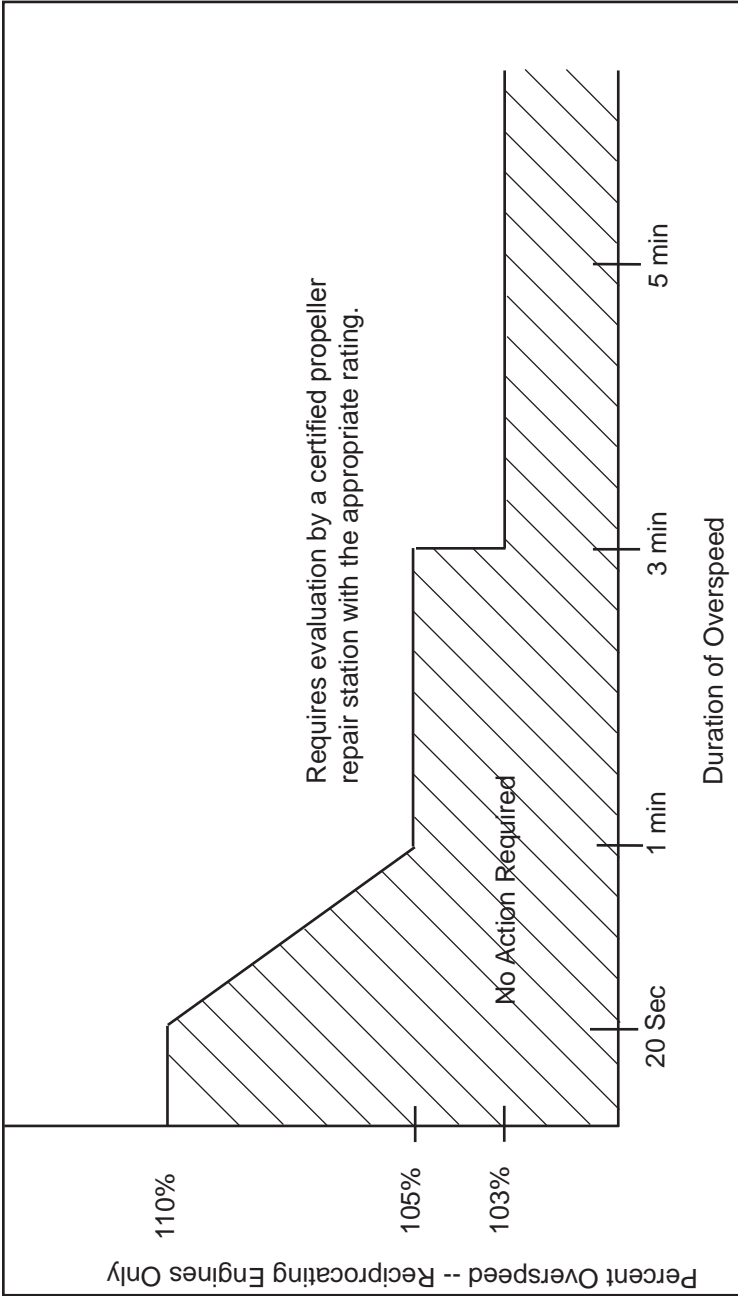

Reciprocating Engine Overspeed Limits
Figure 5-3

5. Special Inspections

CAUTION: INSTRUCTIONS AND PROCEDURES IN THIS SECTION MAY INVOLVE PROPELLER CRITICAL PARTS. REFER TO THE INTRODUCTION CHAPTER OF THIS MANUAL FOR INFORMATION ABOUT PROPELLER CRITICAL PARTS. REFER TO THE ILLUSTRATED PARTS LIST CHAPTER OF THE APPLICABLE OVERHAUL MANUAL(S) FOR THE IDENTIFICATION OF SPECIFIC PROPELLER CRITICAL PARTS.

A. Overspeed

An overspeed has occurred when the propeller RPM has exceeded the maximum RPM stated in the applicable Aircraft Type Certificate Data Sheet. The duration of time and magnitude of overspeed for a single event determines the corrective action that must be taken to ensure no damage to the propeller has occurred.

The criteria for determining the required action after an overspeed are based on many factors. The additional centrifugal forces that occur during overspeed are not the only concern. Some applications have sharp increases in vibratory stresses at RPMs above the maximum rated for the airframe/ engine/propeller combination.

- (1) When a propeller installed on a reciprocating engine has an overspeed event, refer to the Reciprocating Engine Overspeed Limits (Figure 5-3) to determine the corrective action to be taken.
- (2) Make a logbook entry to document the overspeed event.

B. Lightning Strike

CAUTION: ALSO CONSULT ENGINE AND AIRFRAME MANUFACTURER'S MANUALS. THERE MAY BE ADDITIONAL REQUIREMENTS SUCH AS DE-ICE AND ENGINE SYSTEM CHECKS TO PERFORM AFTER A PROPELLER LIGHTNING STRIKE.

(1) General

In the event of a propeller lightning strike, an inspection is required before further flight. It may be permissible to operate a propeller for an additional ten (10) hours of operation if the propeller is not severely damaged and meets the requirements in paragraph 5.B.(2) of this chapter. Regardless of the outcome of the initial inspection, the propeller must eventually be removed from the aircraft, disassembled, evaluated, and/or repaired by a certified propeller repair station with the appropriate rating.

(2) Procedure for Temporary Operation

If temporary additional operation is desired before propeller removal and disassembly:

- (a) Remove the spinner dome and perform visual inspection of propeller, spinner, and de-ice system for evidence of significant damage that would require repair before flight (such as broken de-ice wires or arcing damage to propeller hub).

CAUTION: IF THE PROPELLER EXPERIENCES LIGHTNING STRIKE, THE ALUMINUM BLADES MUST BE WITHIN AIRWORTHY LIMITS FOR ANY ADDITIONAL FLIGHT.

- (b) If the only evident damage is minor arcing burns to the blades, then operation for ten (10) hours is acceptable before disassembly and inspection.
- (c) Perform a functional check of the propeller de-ice system (if installed) in accordance with aircraft maintenance manual procedures.

- (d) Regardless of the degree of damage, make a log book entry to document the lightning strike.
- (e) The propeller must be removed from the aircraft, disassembled, evaluated, and/or repaired by a certified propeller repair station with the appropriate rating for flight beyond the temporary operation limits granted above.

C. Foreign Object Strike/Ground Strike**(1) General**

- (a) A foreign object strike can include a broad spectrum of damage, from a minor stone nick to severe ground impact damage. A conservative approach in evaluating the damage is required because there may be hidden damage that is not readily apparent during an on-wing, visual inspection.
- (b) A foreign object strike is defined as:
 - 1 Any incident, whether or not the engine is operating, that requires repair to the propeller other than minor dressing of the blades. Examples of foreign object strike include situations where an aircraft is stationary and the landing gear collapses causing one or more blades to be significantly damaged, or where a hangar door (or other object) strikes the propeller blade. These cases should be handled as foreign object strikes because of potentially severe side loading on the propeller hub, blades and retention bearings.
 - 2 Any incident during engine operation in which the propeller impacts a solid object that causes a drop in revolutions per minute (RPM) and also requires structural repair of the propeller (incidents requiring only paint touch-up are not included). This is not restricted to propeller strikes against the ground.
 - 3 A sudden RPM drop while impacting water, tall grass, or similar yielding medium, where propeller blade damage is not normally incurred.

I (2) Procedure

- (a) In the event of a foreign object strike, an inspection is required before further flight. If the inspection reveals one or more of the following indications, the propeller must be removed from the aircraft, disassembled and overhauled in accordance with the applicable propeller and blade maintenance manuals.
- 1 A blade rotated in the clamp.
 - 2 Any noticeable or **suspected** damage to the pitch change mechanism.
 - 3 A bent blade (out of track or angle).
 - 4 Any diameter reduction.
 - 5 Blade Damage.
 - 6 A bent, cracked, or failed engine shaft.
 - 7 A blade rotated in the clamp.
 - 8 Vibration during operation that was not present before the event.
- (b) Nicks, gouges, and scratches on blade surfaces or the leading and trailing edges must be removed before flight. Refer to the Blade Repairs section in the Maintenance Practices chapter of this manual.
- (c) Engine mounted components - such as governors, pumps, etc. may be damaged by a foreign object strike, especially if the strike resulted in a sudden stoppage of the engine. These components should be inspected, repaired, or overhauled as recommended by the applicable component maintenance manual.
- (d) Make a log book entry to document the foreign object strike/ground strike incident and any corrective action(s) taken.

D. Fire Damage or Heat Damage

WARNING: HUBS AND CLAMPS ARE MANUFACTURED FROM HEAT TREATED FORGINGS AND ARE SHOT PEENED. BLADES ARE MANUFACTURED FROM HEAT TREATED FORGINGS AND ARE COMPRESSIVELY ROLLED AND SOMETIMES SHOT PEENED. EXPOSURE TO HIGH TEMPERATURES CAN DESTROY THE FATIGUE BENEFITS OBTAINED FROM THESE PROCESSES.

On rare occasions propellers may be exposed to fire or heat damage, such as an engine or hangar fire. In the event of such an incident, an inspection by a certified propeller repair station with the appropriate rating is required before further flight.

6. Long Term Storage

- A.** Parts shipped from the Hartzell Propeller Inc. factory are not shipped or packaged in a container that is designed for long term storage.
- B.** Long term storage procedures may be obtained by contacting a Hartzell distributor, or the Hartzell Propeller Inc. factory via the product support number listed in the Introduction chapter of this manual. Storage information is also detailed in Hartzell Propeller Inc. Standard Practices Manual 202A (61-01-02).
- C.** Information regarding the return of a propeller assembly to service after long term storage may be obtained by contacting a Hartzell distributor, or the Hartzell Propeller Inc. factory via the product support number listed in the Introduction chapter of this manual. This information is also detailed in Hartzell Propeller Inc. Standard Practices Manual 202A (61-01-02).

CONTENTS

1. Cleaning	6-3
A. General Cleaning	6-3
B. Spinner Cleaning and Polishing	6-3
2. Lubrication	6-5
A. Lubrication Intervals	6-5
B. Lubrication Procedure	6-5
C. Approved Lubricants	6-8
3. Carbon Block Assemblies	6-9
A. Inspection	6-9
B. Replacement of A-3026 Carbon Block Unit in the A-3044 Carbon Block Assembly	6-9
C. Installation of the A-3044 Carbon Block Assembly	6-10
4. Blade Repairs	6-13
A. Repair of Nicks and Gouges	6-13
B. Repair of Bent Blades	6-15
5. Painting After Repair	6-16
A. Painting of Aluminum Blades	6-17
6. Dynamic Balance	6-19
A. Overview	6-19
B. Inspection Procedures Before Balancing	6-19
C. Placement of Balance Weights for Dynamic Balance	6-24
7. Propeller Low Pitch Setting	6-26
A. Low Pitch Stop - All Propeller Models	6-26
B. Low pitch measurement on propeller models ()HC-A3()()-2():	6-26
C. Low pitch measurement on propeller models HC-A2()()-2() and ()HC-A()()()-5A(L)	6-27
D. Low pitch measurement on propeller models ()HC-A()()()-1(), ()HC-A()()()-4(), and ()HC-A()()()-6():	6-27

- E. Low pitch measurement on propeller models
BHC-A2()F-3(), HC-A3()F-3L, and ()HC-A3()F-5R: 6-28
- F. Adjusting Low Pitch - Propeller models BHC-A2()F-3(),
HC-A3()F-3L, and ()HC-A3()F-5R: 6-29
- G. Setting Low Pitch Angle - Propeller Models
HC-A()()20-3() 6-31
- 8. Propeller High Pitch Settings 6-31
 - A. High Pitch (Minimum RPM) Stop - Propeller Models
()HC-A()()-1(), ()HC-A()()-3(),
()HC-A()()-4(), and ()HC-A()()-6() 6-31
- 9. Feathering Pitch Stop Settings 6-31
 - A. Feathering Pitch Stop Adjustment - Propeller Models
()HC-A()()-2() and ()HC-A()()-5() 6-31
- 10. Start Lock Settings 6-32
 - A. Start Lock Adjustment - Propeller Models
()HC-A()()-2() and ()HC-A()()-5() 6-32
- 11. Propeller Ice Protection Systems 6-32

FIGURES

- Lubrication Fitting [Figure 6-1](#) 6-4
- Lubrication Label [Figure 6-2](#) 6-6
- Repair Limitations [Figure 6-3](#) 6-12
- Location of Balance Weights [Figure 6-4](#) 6-24
- Adjusting Low Pitch [Figure 6-5](#) 6-28

TABLES

- Approved Touch-up Paints [Table 6-1](#) 6-16
- Maximum Number of Balance Weights For
Non-Standard Installations [Table 6-2](#) 6-21

1. Cleaning

CAUTION: DO NOT USE PRESSURE WASHING EQUIPMENT TO CLEAN THE PROPELLER OR CONTROL COMPONENTS. PRESSURE WASHING CAN FORCE WATER AND/OR CLEANING SOLVENTS PAST SEALS, AND LEAD TO INTERNAL CORROSION OF PROPELLER COMPONENTS.

A. General Cleaning

CAUTION 1: WHEN CLEANING THE PROPELLER, DO NOT ALLOW SOAP OR SOLVENT SOLUTIONS TO RUN OR SPLASH INTO THE HUB AREA.

CAUTION 2: DO NOT CLEAN PROPELLER WITH CAUSTIC OR ACIDIC SOAP SOLUTIONS. IRREPARABLE CORROSION OF PROPELLER COMPONENTS MAY OCCUR.

(1) Wash propeller with a noncorrosive soap solution.

CAUTION: DO NOT USE ANY SOLVENT DURING CLEANING THAT COULD SOFTEN OR DESTROY THE BOND BETWEEN CHEMICALLY ATTACHED PARTS.

(2) To remove grease or oil from propeller surfaces, apply Stoddard Solvent or equivalent to a clean cloth and wipe the part clean.

(3) Thoroughly rinse with water and allow to dry.

B. Spinner Cleaning and Polishing

(1) Clean the spinner using the General Cleaning procedures above.

(2) Polish the dome (if required) with an automotive-type aluminum polish.

D-980

LUBRICATION FITTING
(ONE IN EACH CLAMP HALF)

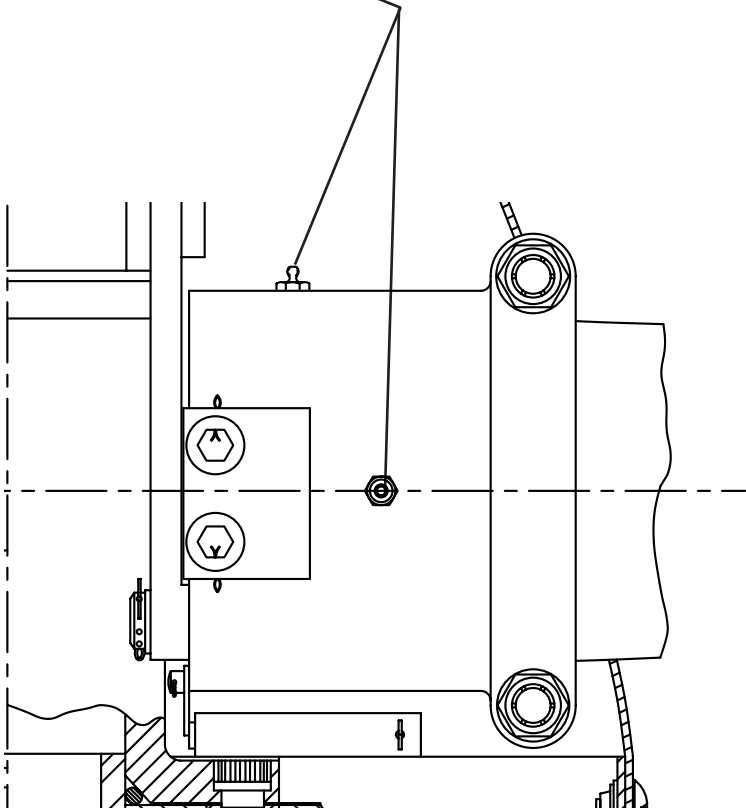

Lubrication Fitting
Figure 6-1

2. Lubrication

CAUTION: INSTRUCTIONS AND PROCEDURES IN THIS SECTION MAY INVOLVE PROPELLER CRITICAL PARTS. REFER TO THE INTRODUCTION CHAPTER OF THIS MANUAL FOR INFORMATION ABOUT PROPELLER CRITICAL PARTS. REFER TO THE ILLUSTRATED PARTS LIST CHAPTER OF THE APPLICABLE OVERHAUL MANUAL(S) FOR THE IDENTIFICATION OF SPECIFIC PROPELLER CRITICAL PARTS.

A. Lubrication Intervals

- (1) The propeller must be lubricated at intervals not to exceed 100 hours, or at twelve (12) calendar months, whichever occurs first.

NOTE 1: If annual operation is significantly less than 100 hours, calendar lubrication intervals should be reduced to six months.

NOTE 2: If the aircraft is operated or stored under adverse atmospheric conditions (e.g. high humidity, salt air) calendar lubrication intervals should be reduced to six months.

- (2) Owners of high use aircraft may wish to extend their lubrication intervals. Lubrication interval may be gradually extended after evaluation of previous propeller overhauls, with regard to bearing wear and internal corrosion.

- (3) New or newly overhauled propellers should be lubricated after the first one or two hours of operation, because centrifugal loads will pack and redistribute grease.

NOTE: Purchasers of new aircraft should check the propeller logbook to verify whether the propeller was lubricated by the manufacturer during flight testing. If not, the propeller should be serviced at earliest convenience.

B. Lubrication Procedure

CAUTION: FOLLOW LUBRICATION PROCEDURES CORRECTLY TO MAINTAIN AN ACCURATE BALANCE OF THE PROPELLER ASSEMBLY.

- (1) Remove the propeller spinner.

- (2) Refer to Figure 6-1. Each blade clamp has two lubrication fittings. Remove both lubrication fitting caps and one of the lubrication fittings from each blade clamp.
- (3) Use a piece of safety wire to loosen any blockage or hardened grease at the threaded holes where the lubrication fitting was removed.

WARNING: WHEN MIXING AEROSHELL GREASES 5 AND 6, AEROSHELL GREASE 5 MUST BE INDICATED ON THE LABEL (HARTZELL P/N A-3594) AND THE AIRCRAFT MUST BE PLACARDED TO INDICATE THAT FLIGHT IS PROHIBITED IF THE OUTSIDE AIR TEMPERATURE IS LESS THAN -40°F (-40°C).

CAUTION: USE HARTZELL PROPELLER APPROVED GREASE ONLY. EXCEPT IN THE CASE OF AEROSHELL GREASES 5 AND 6, DO NOT MIX DIFFERENT SPECIFICATIONS AND/OR BRANDS OF GREASE.

- (4) Aeroshell greases 5 and 6 both have a mineral oil base and have the same thickening agent; therefore, mixing of these two greases is acceptable in Hartzell propellers.

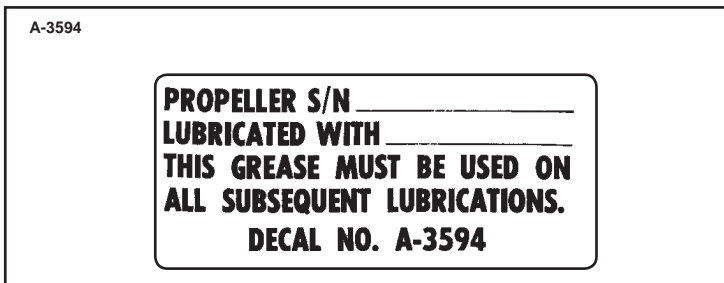

Lubrication Label
Figure 6-2

- (5) A label (Hartzell P/N A-3494) is normally applied to the propeller to indicate the type of grease previously used (Figure 6-2).
 - (a) This grease type should be used during re-lubrication unless the propeller has been disassembled and the old grease removed.
 - (b) Purging of old grease through lubrication fittings is only about 30 percent effective.
 - (c) To completely replace one grease with another, the propeller must be disassembled in accordance with the applicable overhaul manual.

CAUTION: IF A PNEUMATIC GREASE GUN IS USED TO LUBRICATE THE PROPELLER, TAKE EXTRA CARE TO AVOID EXCESSIVE PRESSURE BUILDUP.

- (6) Pump grease into the blade clamp grease fitting until grease emerges from the hole of the removed lubrication fitting.

NOTE: Lubrication is complete when grease emerges in a steady flow with no air pockets or moisture, and has the color and texture of the new grease.
- (7) Reinstall the removed lubrication fitting on each clamp.
- (8) Tighten the lubrication fittings until snug.
 - (a) Make sure the ball of each lubrication fitting is properly seated.
- (9) Install a new lubrication fitting cap on each lubrication fitting.

C. Approved Lubricants

(1) The following lubricants are approved for use in Hartzell propellers:

Aeroshell 6 - Recommended "all purpose" grease. Used in most new production propellers since 1989. Higher leakage/oil separation than Aeroshell 5 at higher temperatures (approximately 100°F [38°C]).

Aeroshell 5 - Good high temperature qualities, very little oil separation or leakage. Cannot be used in temperatures colder than -40°F (-40°C). Aircraft serviced with this grease must be placarded to indicate that flight is prohibited if the outside air temperature is less than -40°F (-40°C).

Aeroshell 7 - Good low temperature grease, but high leakage/oil separation at higher temperatures. This grease has been associated with sporadic problems involving seal swelling.

Aeroshell 22 - Qualities similar to Aeroshell 7.

Royco 22CF - Not widely used. Qualities similar to Aeroshell 22.

(2) A label (Figure 6-2) indicating the type of grease used for previous lubrication (if used) is installed on the propeller piston or on the blade clamp. If the propeller is to be lubricated with a different type of grease, the propeller must be disassembled and cleaned of old grease before relubricating.

3. Carbon Block Assemblies

CAUTION: INSTRUCTIONS AND PROCEDURES IN THIS SECTION MAY INVOLVE PROPELLER CRITICAL PARTS. REFER TO THE INTRODUCTION CHAPTER OF THIS MANUAL FOR INFORMATION ABOUT PROPELLER CRITICAL PARTS. REFER TO THE ILLUSTRATED PARTS LIST CHAPTER OF THE APPLICABLE OVERHAUL MANUAL(S) FOR THE IDENTIFICATION OF SPECIFIC PROPELLER CRITICAL PARTS.

A. Inspection

The clearance between the yoke pin and the corresponding linkage (beta lever bushing) can become too close due to a buildup of plating and foreign particles between the two pieces. This can cause a binding action, resulting in excessive wear to the carbon block, low stop collar, and beta linkage.

- (1) Inspect the beta lever and carbon block interface for free movement. If there is binding, do the following:
 - (a) Disconnect the beta linkage and remove the carbon block assemblies from the beta ring.
 - (b) Polish the yoke pin to provide adequate clearance and eliminate binding.
 - (c) Reinstall the carbon block assembly into the beta ring.
 - (d) Install, adjust and safety the beta linkage in accordance with the airframe manufacturer's instructions.

B. Replacement of A-3026 Carbon Block Unit in the A-3044 Carbon Block Assembly

Replace an A-3026 carbon block unit if the side clearance between the beta ring and carbon block exceeds 0.010 inch (0.25 mm).

- (1) Remove the cotter pin from the end of the clevis pin.
- (2) Slide the pin from the assembly and remove and discard the carbon block unit.
- (3) Inspect the yoke for wear or cracks. Replace the yoke, if necessary.

- (4) Install a new carbon block unit and slide a new clevis pin into place.
 - (5) Secure the clevis pin with a T-head cotter pin (Figure 3-15).
 - (6) Refit the carbon block (Figure 3-14).
 - (a) Establish the required clearance by sanding the sides of the carbon block as needed.
- C. Installation of the A-3044 Carbon Block Assembly
- Refer to Installation and Removal chapter of this manual for installation instructions.

(This page is intentionally blank.)

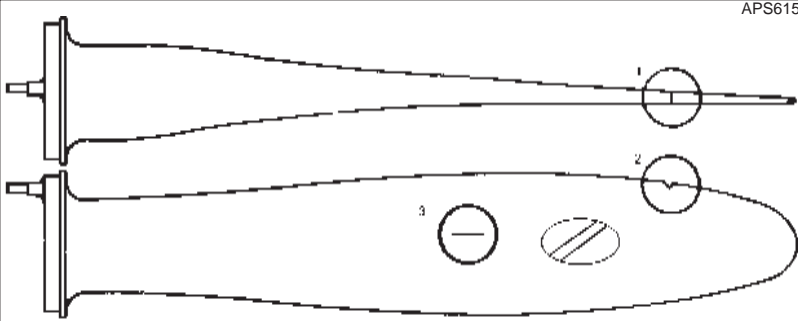

Example 1

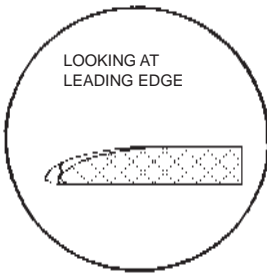

Example 2

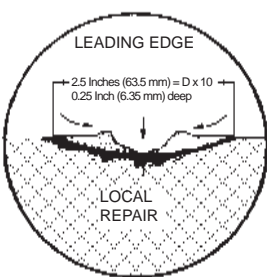

Example 3

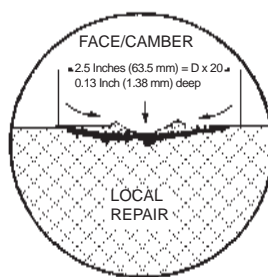

To determine amount of rework needed, use the following formula:

On the leading and trailing edge of the blade, measure the depth of the damage, and multiply this number x 10 (see Example 2, above). Rework the area surrounding the damage 10 times the depth of the damage.

On the face and camber of the blade, measure the depth of the damage, and multiply this number x 20 (see Example 3, above). Rework the area surrounding the damage 20 times the depth of the damage.

Repair Limitations
Figure 6-3

4. Blade Repairs

WARNING: ALL NICKS, GOUGES, OR SCRATCHES OF ANY SIZE CAN CREATE A STRESS RISER THAT COULD POTENTIALLY LEAD TO BLADE CRACKING. ALL DAMAGE SHOULD BE VISUALLY EXAMINED CAREFULLY BEFORE FLIGHT FOR THE PRESENCE OF CRACKS OR OTHER ABNORMALITIES.

CAUTION 1: BLADES THAT HAVE BEEN PREVIOUSLY REPAIRED OR OVERHAULED MAY HAVE BEEN DIMENSIONALLY REDUCED. BEFORE REPAIRING SIGNIFICANT DAMAGE OR MAKING REPAIRS ON BLADES THAT ARE APPROACHING SERVICEABLE LIMITS, CONTACT A CERTIFIED PROPELLER REPAIR STATION WITH THE APPROPRIATE RATING. OR THE HARTZELL PRODUCT SUPPORT DEPARTMENT FOR BLADE DIMENSIONAL LIMITS.

CAUTION 2: INSTRUCTIONS AND PROCEDURES IN THIS SECTION MAY INVOLVE PROPELLER CRITICAL PARTS. REFER TO THE INTRODUCTION CHAPTER OF THIS MANUAL FOR INFORMATION ABOUT PROPELLER CRITICAL PARTS. REFER TO THE ILLUSTRATED PARTS LIST CHAPTER OF THE APPLICABLE OVERHAUL MANUAL(S) FOR THE IDENTIFICATION OF SPECIFIC PROPELLER CRITICAL PARTS.

Nicks, gouges, and scratches on blade surfaces or on the leading or trailing edges of the blade, greater than 1/32 inch wide or deep, must be removed before flight. Field repair of small nicks and scratches may be performed by qualified personnel in accordance with FAA Advisory Circular 43.13-1B, as well as the procedures specified below. Normal blade lead edge erosion (sand-blasted appearance) is acceptable, and does not require removal before further flight.

A. Repair of Nicks and Gouges

Local repairs may be made using files, electrical or air powered equipment. Emery cloth, scotch brite, and crocus cloth are to be used for final finishing. Refer to Figure 6-3.

CAUTION 1: REWORK THAT INVOLVES COLD WORKING THE METAL, RESULTING IN CONCEALMENT OF A DAMAGED AREA, IS NOT ACCEPTABLE. A STRESS CONCENTRATION MAY EXIST THAT CAN RESULT IN A BLADE FAILURE.

CAUTION 2: SHOT PEENED BLADES ARE IDENTIFIED WITH AN "S" IMMEDIATELY FOLLOWING THE BLADE MODEL NUMBER, AS DESCRIBED IN THE DESCRIPTION AND OPERATION CHAPTER OF THIS MANUAL. BLADES THAT HAVE DAMAGE IN SHOT PEENED AREAS IN EXCESS OF 0.015 INCH (0.38 mm) DEEP ON THE FACE OR CAMBER OR 0.250 INCH (6.35 mm) ON THE LEADING OR TRAILING EDGES MUST BE REMOVED FROM SERVICE, AND THE REWORKED AREA SHOT PEENED BEFORE FURTHER FLIGHT. SHOT PEENING OF AN ALUMINUM BLADE MUST BE ACCOMPLISHED BY A CERTIFIED PROPELLER REPAIR STATION WITH THE APPROPRIATE RATING. IN ACCORDANCE WITH HARTZELL ALUMINUM BLADE OVERHAUL MANUAL 133C (61-13-33).

- (1) Repairs to the leading or trailing edge are to be accomplished by removing material from the bottom of the damaged area. Remove material from this point out to both sides of the damage, providing a smooth, blended depression which maintains the original airfoil general shape.
- (2) Repairs to the blade face or camber should be made in the same manner as above. Repairs that form a continuous line across the blade section (chordwise) are unacceptable.

- (3) The area of repair should be determined as follows:
Leading and trailing edge damage: Depth of nick x 10.
Face and camber: Depth of nick x 20. Refer to Figure 6-3.

NOTE: Leading edge includes the first 10 percent of chord from the leading edge. The trailing edge consists of the last 20 percent of chord adjacent to the trailing edge.

- (4) After filing or sanding of the damaged area, the area must then be polished, with emery cloth and finally with crocus cloth to remove any traces of filing.
- (5) Inspect the repaired area with a 10X magnifying glass. Make sure that no indication of the damage, file marks, or coarse surface finish remain.
- (6) If inspections show any remaining blade damage, repeat steps 3.A.(4) and 3.A.(5) until no damage remains. Penetrant inspection is recommended in accordance with Hartzell Propeller Inc. Standard Practices Manual 202A (61-01-02).
- (7) Treat the repaired area to prevent corrosion. Properly apply chemical conversion coating and approved paint to the repaired area before returning the blade to service. Refer to Painting After Repair in this section.

B. Repair of Bent Blades

CAUTION: DO NOT ATTEMPT TO "PRE-STRAIGHTEN" A BLADE BEFORE DELIVERY TO A CERTIFIED PROPELLER REPAIR STATION WITH THE APPROPRIATE RATING. THIS WILL CAUSE THE BLADE TO BE REPLACED BY THE REPAIR FACILITY.

Repair of a bent blade or blades is considered a major repair. This type of repair must be accomplished by a certified propeller repair station with the appropriate rating, and only within approved guidelines.

5. Painting After Repair

CAUTION: INSTRUCTIONS AND PROCEDURES IN THIS SECTION MAY INVOLVE PROPELLER CRITICAL PARTS. REFER TO THE INTRODUCTION CHAPTER OF THIS MANUAL FOR INFORMATION ABOUT PROPELLER CRITICAL PARTS. REFER TO THE ILLUSTRATED PARTS LIST CHAPTER OF THE APPLICABLE OVERHAUL MANUAL(S) FOR THE IDENTIFICATION OF SPECIFIC PROPELLER CRITICAL PARTS.

Propeller blades are painted with a durable specialized coating that is resistant to abrasion. If this coating becomes eroded, it is necessary to repaint the blades to provide proper corrosion and erosion protection. Painting should be performed by an appropriately licensed propeller repair facility in accordance with Hartzell Propeller Inc. Standard Practices Manual 202A (61-01-02). It is permissible to perform a blade touch-up with aerosol paint in accordance with the procedures in Painting of Aluminum Blades, below.

The following paints (Table 6-1) are approved for blade touch-up:

Vendor	Color/Type	Vendor P/N	Hartzell P/N
Tempo	Epoxy Black	A-150	n/a
Tempo	Epoxy Gray	A-151	n/a
Tempo	Epoxy White (tip stripe)	A-152	n/a
Tempo	Epoxy Red (tip stripe)	A-153	n/a
Tempo	Epoxy Yellow (tip stripe)	A-154	n/a
Sherwin-Williams	Black	F75KXB9958-4311	A-6741-145-1
Sherwin-Williams	Gray	F75KXA10445-4311	A-6741-146-1
Sherwin-Williams	White (tip stripe)	F75KXW10309-4311	A-6741-147-1
Sherwin-Williams	Red (tip stripe)	F75KXR12320-4311	A-6741-149-1
Sherwin-Williams	Yellow (tip stripe)	F75KXY11841-4311	A-6741-150-1
Sherwin-Williams	Silver	F75KXS13564-4311	A-6741-190-1

**Approved Touch-up Paints
Table 6-1**

The paint manufacturers may be contacted as listed below:

Tempo Products Co.

A plasti-kote Company
1000 Lake Road
Medina, OH 44256
Tel: 800.321.6301
Fax: 440.248.1348
Cage Code: 07708

Sherwin Williams Co.

2390 Arbor Boulevard
Dayton, Ohio
Tel: 937.298.8691
Fax: 937.298.3820
Cage Code: 0W199

A. Painting of Aluminum Blades

WARNING: CLEANING AGENTS (ACETONE, #700 LACQUER THINNER, AND MEK), ARE FLAMMABLE AND TOXIC TO THE SKIN, EYES, AND RESPIRATORY TRACT. SKIN AND EYE PROTECTION ARE REQUIRED. AVOID PROLONGED CONTACT. USE IN A WELL VENTILATED AREA.

CAUTION: ANY REFINISHING PROCEDURE CAN ALTER PROPELLER BALANCE. PROPELLERS THAT ARE OUT OF BALANCE MAY EXPERIENCE EXCESSIVE VIBRATIONS WHILE IN OPERATION.

- (1) Using acetone, #700 lacquer thinner, or MEK, wipe the surface of the blade to remove any contaminants.
- (2) Feather the existing coatings away from the eroded or repaired area with 120 to 180 grit sandpaper.

NOTE: Paint erosion is typically very similar on all blades in a propeller assembly. If one blade has more extensive damage, e.g. in the tip area, all the blades should be sanded in the tip area to replicate the repair of the most severely damaged blade tip. This practice is essential in maintaining balance after refinishing.

- (3) Use acetone, #700 lacquer thinner, or MEK to wipe the surface of the blade. Allow solvent to evaporate.

- (4) Before refinishing the blades, apply a corrosion preventive coating to the bare aluminum surface. Oakite 31, Chromicote L-25, or Alodine 1201 are approved chemical conversion coatings. Apply these coatings in accordance with the directions provided by the product manufacturer.
- (5) Mask off deice boot and tip stripes, as needed.

WARNING: FINISH COATINGS ARE FLAMMABLE AND TOXIC TO THE SKIN, EYES, AND RESPIRATORY TRACT. SKIN AND EYE PROTECTION ARE REQUIRED. AVOID PROLONGED CONTACT. USE IN A WELL VENTILATED AREA.

CAUTION: APPLY FINISH COATING ONLY TO THE DEGREE REQUIRED TO UNIFORMLY COVER THE REPAIR/EROSION. AVOID EXCESSIVE PAINT BUILDUP ALONG THE TRAILING EDGE TO AVOID CHANGING BLADE PROFILE.

- (6) Apply sufficient finish coating to achieve 2 to 4 mils thickness when dry. Re-coat before 30 minutes, or after 48 hours. If the paint is allowed to dry longer than four (4) hours, it must be lightly sanded before another coat is applied.
- (7) Remove the masking from the tip stripes and re-mask to allow for the tip stripe refinishing, if required.
- (8) Apply sufficient tip stripe coating to achieve 2 to 4 mils thickness when dry. Re-coat before 30 minutes, or after 48 hours. If the paint is allowed to dry longer than four (4) hours, it must be lightly sanded before another coat is applied.
- (9) Remove the masking immediately from the de-ice boot and tip stripes, if required.
- (10) Optionally, perform dynamic balancing in accordance with the procedures and limitations specified in Dynamic Balance section of this chapter.

6. Dynamic Balance**A. Overview**

WARNING: WHEN USING REFLECTIVE TAPE FOR DYNAMIC BALANCING, DO NOT APPLY THE TAPE ON EXPOSED BARE METAL OF A BLADE. THIS WILL PERMIT MOISTURE TO COLLECT UNDER THE TAPE AND CAUSE CORROSION THAT CAN PERMANENTLY DAMAGE THE BLADE. REFLECTIVE TAPE MUST BE REMOVED AFTER DYNAMIC BALANCING IS COMPLETED.

CAUTION: INSTRUCTIONS AND PROCEDURES IN THIS SECTION MAY INVOLVE PROPELLER CRITICAL PARTS. REFER TO THE INTRODUCTION CHAPTER OF THIS MANUAL FOR INFORMATION ABOUT PROPELLER CRITICAL PARTS. REFER TO THE ILLUSTRATED PARTS LIST CHAPTER OF THE APPLICABLE OVERHAUL MANUAL(S) FOR THE IDENTIFICATION OF SPECIFIC PROPELLER CRITICAL PARTS.

NOTE: Dynamic balance is recommended to reduce vibrations which may be caused by a rotating system (propeller and engine) imbalance. Dynamic balancing can help prolong the life of the propeller, engine, airframe, and avionics.

- (1) Dynamic balance is accomplished by using an accurate means of measuring the amount and location of the dynamic imbalance.
- (2) The number of balance weights installed must not exceed the limits specified in this chapter.
- (3) Follow the dynamic balance equipment manufacturer's instructions for dynamic balance in addition to the specifications of this section.

NOTE: Some engine manufacturers' instructions also contain information on dynamic balance limits.

- (4) Unless otherwise specified by the engine or airframe manufacturer, Hartzell recommends that the propeller be dynamically balanced to a reading of 0.2 IPS or less.

B. Inspection Procedures Before Balancing

- (1) Visually inspect the propeller assembly before dynamic balancing.

NOTE: The first run-up of a new or overhauled propeller assembly may leave a small amount of grease on the blades and inner surface of the spinner dome.

- (a) Use Stoddard solvent (or equivalent) to completely remove any grease on the blades or inner surface of the spinner dome.
 - (b) Visually check each propeller blade assembly for evidence of grease leakage.
 - (c) Visually inspect the inner surface of the spinner dome for evidence of grease leakage.
- (2) If there is no evidence of grease leakage, lubricate the propeller in accordance with the Maintenance Practices chapter in this manual. If grease leakage is evident, determine the location of the leak and correct before lubricating the propeller and dynamic balancing.
 - (3) Before dynamic balance record the number and location of all balance weights.
 - (4) Static balance is accomplished at a propeller overhaul facility when an overhaul or major repair is performed.

NOTE: If static balancing is not accomplished before dynamic balancing, the propeller may be so severely unbalanced that dynamic balance may be unachievable due to measurement equipment limitations.

A-48 Weight Slug Limits on C-3-() and D-6831-() Clamps

C-3-() and D-6831-() clamps have only two locations for the A-48, A-48A or A-1419 weight slugs (Figure 604A). Clamps may have tapped holes on the inboard side of the clamp outboard bolt lugs providing an alternate mounting location if it is necessary to move the weight slugs to clear the spinner.

NOTE: A-48 (steel) weight slugs may be replaced with A-48A (lead) weight slugs although the most outboard slug must be an A-48 (steel) weight slug. The number limits for slugs still applies.

<u>Aircraft Mfg.</u>	<u>Propeller Model</u>	<u>Spinner</u>		
		<u>Assembly</u>	<u>Lead**</u>	<u>Trail*</u>
Aero Commander	HC-A2(V,MV)F-2()/(V,MV)8433()-4	C-2530	3	4
Aero Commander	HC-A3(V,MV)20-2()/(V,MV)9333()	---	0	3-See Note 1
Beech	HC-A3(V,MV)20-2()/(V,MV)9333()-3	---	0	3
Riley	HC-A3(V,MV)K-2()/(V,MV)7636()	A-835-()	4	2-See Note 2
Riley	HC-A3(V,MV)K-2()/(V,MV)7636()	C-2513-()	4-See Note 3	4

** "Lead" and "Trail" refer to the weight location on the outboard bolt lugs of the C-3-() and the D-6831-() clamps as referenced to the blade lead and trail edges.

**Maximum Number of Balance Weights for Non-Standard Installations
Table 6-2**

<u>Spinner Aircraft Mfg.</u>	<u>Propeller Model</u>	<u>Assembly</u>	<u>Lead**</u>	<u>Trail**</u>
Beech	PHC-A3(V,MV)F-2 ()/(V,MV)7636()	A-836-36, -37	0	4-See Note 4
Beech / Colemill	EHC-A3(V,MV)F-2 ()/(V,MV)7636()	A-836-36	0	4-See Note 4
Colemill Commander	EHC-A3(V,MV)F-2 ()/(V,MV)7636()	A-836-25	0	4
Excaliber	HC-A3(V,MV)K-2 ()/(V,MV)8433()-2R	---	0	4
Beech	HC-A3(V,MV)K-2 ()/(V,MV)9333()-3	---	0	3-See Note 1
Cessna 411	HC-A3(V,MV)F-2 ()/(V,MV)8833()	---	4	0
Beagle	HC-A3(V,MV)F-2 ()/(V,MV)8833()	---	0	3
Beech	HC-A3(V,MV)F-4/(V,MV)8433()-4R	---	---	See Note 5
Piper	HC-A3(V,MV)F-4/(V,MV)8433()-7	---	---	See Note 5
Prinair	EHC-A3(V,MV)F-2 ()/(V,MV)7636()	---	---	See Note 6
Beech	HC-A2(V,MV)20-4()/(V,MV)8833()-4	---	---	See Note 6

** "Lead" and "Trail" refer to the weight location on the outboard bolt lugs of the C-3(-) and the D-6831(-) clamps as referenced to the blade lead and trail edges.

Maximum Number of Balance Weights for Non-Standard Installations
Table 6-2, Continued

<u>Spinner Aircraft Mfg.</u>	<u>Propeller Model</u>	<u>Assembly</u>	<u>Lead**</u>	<u>Trail**</u>
Beech	HC-A2(V,MV)20-4()/(V,MV)8433()	---	See Note 6	
Navion	HC-A2(V,MV)20-4()/(V,MV)8433()	---	See Note 6	
<p>** "Lead" and "Trail" refer to the weight location on the outboard bolt lugs of the C-3-() and the D-6831-() clamps as referenced to the blade lead and trail edges.</p>				
<hr/>				
<u>Note 1:</u>	Three A-48 weight slugs or two A-1419 weight slugs.			
<u>Note 2:</u>	Two A-48 weight slugs or one A-1419 weight slugs.			
<u>Note 3:</u>	Four A-48 weight slugs or two A-1419 weight slugs.			
<u>Note 4:</u>	Four A-48 weight slugs or two A-1419 weight slugs and one A-48 weight slug.			
<u>Note 5:</u>	Four A-48 weight slugs on counterweight and five A-48 weight slugs on clamp on inboard side of outboard clamp bolt shoulder of clamp.			
<u>Note 6:</u>	A-48 weight slugs are only attached to the nut plates mounted on the spinner bulkhead. Maximum of (4) per location.			

**Maximum Number of Balance Weights for Non-Standard Installations
Table 6-2, Continued**

C. Placement of Balance Weights for Dynamic Balance

(1) The preferred method of attachment of dynamic balance weights is to add the weights to the spinner bulkhead; however, the configuration of the spinner bulkhead on many of the propeller models covered in this manual makes it impractical to mount dynamic balance weights in this manner. Dynamic balance must be accomplished through the removal or addition and/or the relocation of the static balance weights located on the blade clamps.

(a) Each blade clamp has four balance weight locations on the outboard circular surface of the clamp (Figure 6-4).

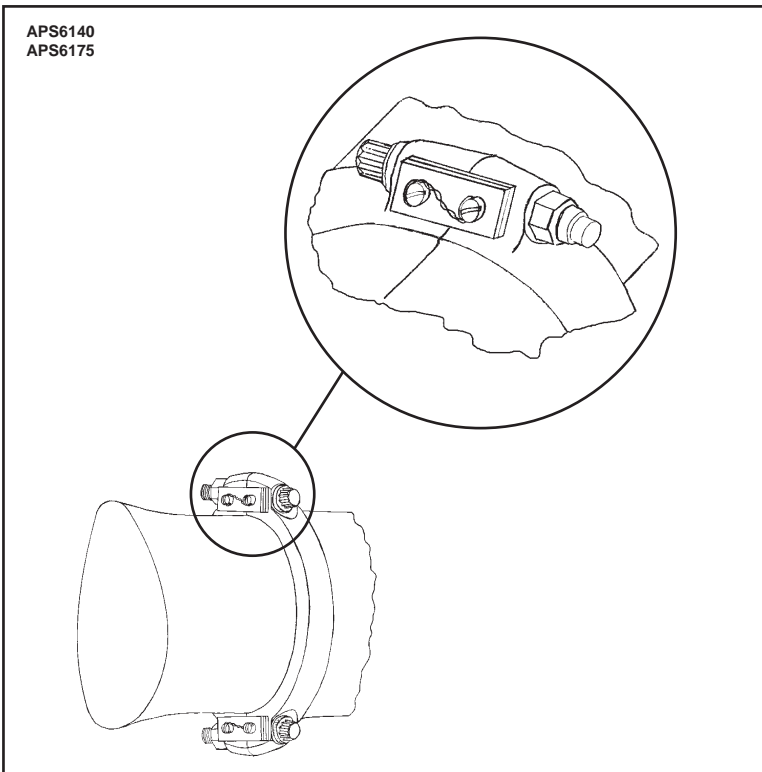

Location of Balance Weights
Figure 6-4

- (b) Maximum number of balance weights per location
- 1 For standard installations, the maximum number of balance weights per location is four (4).

NOTE: For propellers with a deice system using a blade clamp-mounted lead strap restraint, a maximum of three weights may be attached to the clamp with the de-ice lead strap restraint.

- 2 For nonstandard installations, refer to Table 6-2 for balance weight information.

CAUTION 1: BEFORE DYNAMIC BALANCE, RECORD THE NUMBER AND LOCATION OF ALL STATIC BALANCE WEIGHTS.

CAUTION 2: USE ONLY BALANCE WEIGHTS A-48, A-48A, OR A-1419.

CAUTION 3: DO NOT EXCEED THE MAXIMUM NUMBER OF BALANCE WEIGHTS PER LOCATION.

- (c) Alter the number and/or location of static balance weights as necessary to achieve dynamic balance.
- (2) If reflective tape is used for dynamic balancing, remove the tape immediately upon completion of dynamic balancing.
 - (3) Record the number and location of static balance weights, if they have been reconfigured, in the logbook.

7. Propeller Low Pitch Setting

NOTE: The information contained in this section does not apply to ground adjustable propeller model HA-A2MV20-1B.

WARNING 1: RPM ADJUSTMENTS MUST BE MADE WITH REFERENCE TO A CALIBRATED TACHOMETER. AIRCRAFT MECHANICAL TACHOMETERS DEVELOP ERRORS OVER TIME, AND SHOULD BE PERIODICALLY RECALIBRATED TO MAKE SURE THE PROPER RPM IS DISPLAYED.

WARNING 2: LOW PITCH BLADE ANGLE ADJUSTMENTS MUST BE MADE IN CONSULTATION WITH THE APPLICABLE TYPE CERTIFICATE OR SUPPLEMENTAL TYPE CERTIFICATE HOLDERS APPROVED MAINTENANCE DATA.

CAUTION: INSTRUCTIONS AND PROCEDURES IN THIS SECTION MAY INVOLVE PROPELLER CRITICAL PARTS. REFER TO THE INTRODUCTION CHAPTER OF THIS MANUAL FOR INFORMATION ABOUT PROPELLER CRITICAL PARTS. REFER TO THE ILLUSTRATED PARTS LIST CHAPTER OF THE APPLICABLE OVERHAUL MANUAL(S) FOR THE IDENTIFICATION OF SPECIFIC PROPELLER CRITICAL PARTS.

A. Low Pitch Stop - All Propeller Models

The propeller low pitch stop is set at the factory to the aircraft TC or STC Holder's requirements and should not require any additional adjustment. The TC or STC Holder provides the required low pitch stop blade angle and may also provide the acceptable RPM range for a maximum power static condition. Be aware that the aircraft TC or STC holder may specify the static RPM to be less than the RPM to which the engine is rated.

- B. Low pitch measurement on propeller models
()HC-A3()()-2():

CAUTION: PLACE A PAN UNDER THE PROPELLER PISTON BEFORE REMOVING THE NUT AND MOVING THE PISTON, AS ENGINE OIL MAY COME OUT OF THE OPENING IN THE PISTON.

- (1) Remove the piston nut from the pitch change rod.
- (2) Rotate the blades by hand to move the blades and piston to low pitch.

NOTE: Low pitch is reached when a washer on the end of each piston guide rod stops against the guide collar.

- (3) With the blade in a horizontal position, measure low pitch blade angle.
- (4) If the blade angle requires adjustment, have the low pitch stop adjusted by an appropriately licensed propeller repair facility or by the Hartzell factory.

- C. Low pitch measurement on propeller models
HC-A2()()-2() and ()HC-A()()()-5A(L)

- (a) Low pitch measurement must be performed at an appropriately licensed propeller repair facility or at the Hartzell factory.

- D. Low pitch measurement on propeller models

()HC-A()()()-1(), ()HC-A()()()-4(), and ()HC-A()()()-6():

- (1) Rotate the blades by hand to move the blades and piston to low pitch.
- (2) With the blade in a horizontal position, measure the low pitch blade angle.
- (3) If the blade angle requires adjustment, have the low pitch stop adjusted by an appropriately licensed propeller repair facility or by the Hartzell factory.

- E. Low pitch measurement on propeller models BHC-A2()F-3(), HC-A3()F-3L, and ()HC-A3()F-5R:

CAUTION: PLACE A PAN UNDER THE PROPELLER PISTON BEFORE REMOVING THE NUT AND MOVING THE PISTON, AS ENGINE OIL MAY COME OUT OF THE OPENING IN THE PISTON.

- (1) Remove the piston nut from the pitch change rod.
- (2) Rotate the blades by hand to move the blades and piston to low pitch.

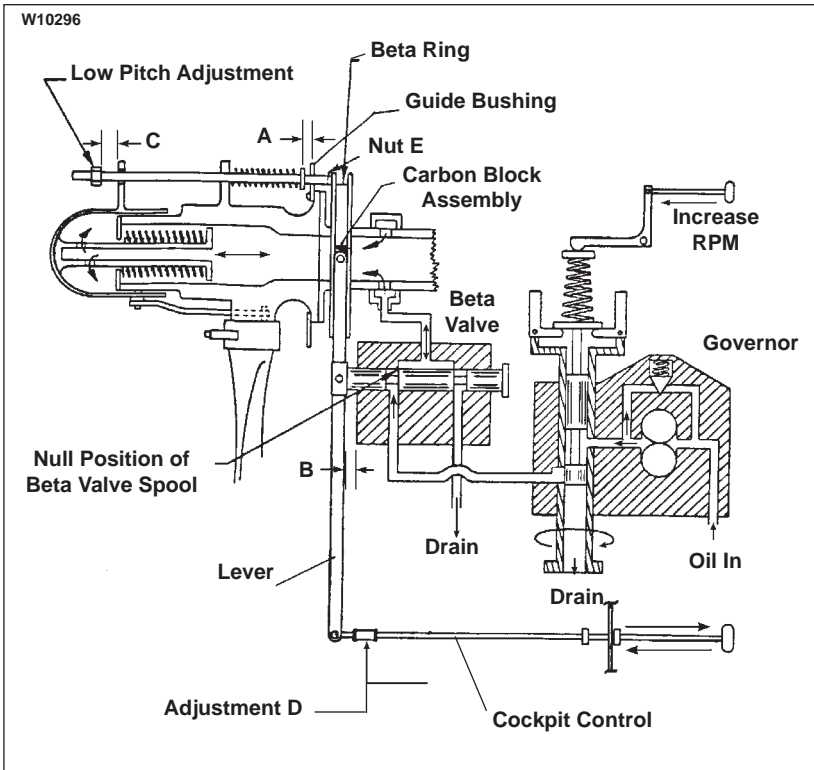

Adjusting Low Pitch
Figure 6-5

NOTE: Low pitch is reached when the piston ears contact the self-locking nut on each rod, and when distance "C" is zero. Refer to Figure 3-17.

- (3) With the blade in a horizontal position, measure low pitch blade angle.
 - (4) If the blade angle requires adjustment, refer to Adjusting Low Pitch - Propeller models BHC-A2()F-3(), HC-A3()F-3L, and ()HC-A3()F-5R in this chapter.
- F. Adjusting Low Pitch - Propeller models BHC-A2()F-3(), HC-A3()F-3L, and ()HC-A3()F-5R:

WARNING 1: LOW PITCH BLADE ANGLE ADJUSTMENTS MUST BE MADE IN CONSULTATION WITH THE APPLICABLE TYPE CERTIFICATE OR SUPPLEMENTAL TYPE CERTIFICATE HOLDER'S MAINTENANCE DATA.

WARNING 2: ADJUSTMENT OF THE LOW PITCH STOP TO ACHIEVE THE SPECIFIED STATIC RPM MAY MASK AN ENGINE POWER PROBLEM.

- (1) Refer to the following procedure for accomplishing an adjustment to the low pitch angle:
 - (a) The low pitch adjustment "C" (Figure 6-5) has been made at the factory, according to published information. The readjustment of low pitch should not be required, although it is accomplished by adjusting four nuts, as shown in Figure 6-5, if the maximum engine/propeller RPM is incorrect.

(b) To check the maximum engine/propeller RPM, start the engine and check the RPM for full throttle operation. The RPM should correspond to the maximum rated engine RPM. The governor must be set for maximum RPM for this test.

- 1 If the RPM is too low, back the four low pitch adjustment nuts **out** approximately 3/4 of a turn (3/4 of a turn equals approximately 100 RPM increase). If this process does not increase the RPM, this means that the governor is limiting the RPM by calling for increased pitch. In this case, the governor must be adjusted to provide for higher RPM (increased compression on the speeder spring).

CAUTION: TO PREVENT THE RPM FROM EXCEEDING THE ENGINE RATING, TURN THE LOW PITCH ADJUSTMENT NUTS **IN** APPROXIMATELY 3/4 OF A TURN TO OBTAIN A 100 RPM REDUCTION.

- 2 An alternative method for determining whether the low pitch adjustment is limiting the RPM is to observe the movement of the beta valve spool during maximum power. "B" will increase from 1/16 inch (1.6 mm) to 3/16 inch (4.8 mm) during run-up of the engine for proper adjustment of the governor.

- (c) The beta ring run-out can be checked by installing a dial indicator on the nose of the engine, so that it touches the rear face of the beta ring. If necessary, loosen nut "E" and rotate the rods to bring the run-out to within 0.010 total indicator reading.
- (d) Torque nut "E" to 10-15 Ft. Lb (14-20 N•m).

- (e) Make sure the four low pitch adjusting nuts contact the piston bosses at the same time.

NOTE: This will insure that the beta ring runs true during pitch change reversal.

To accomplish this:

- 1 Equalize "C" (Figure 6-5) for all four rods by means of accurate measurements.
- 2 Adjust the nuts if necessary.

G. **Setting Low Pitch Angle - Propeller Models HC-A() ()20-3()**

- (1) The low pitch blade angle is normally set at the factory or propeller overhaul facility per the aircraft manufacturer's requirements. Information tags that specify the proper dimensional position for the low pitch nuts are normally attached to each reverse return spring (on the beta rod).
- (2) If the blade angle requires adjustment, have the low pitch stop adjusted at an appropriately licensed propeller repair facility or at the Hartzell factory.

8. **Propeller High Pitch Settings**

- A. **High Pitch (Minimum RPM) Stop - Propeller Models ()HC-A() ()-1(), ()HC-A() ()-3(), ()HC-A() ()-4(), and ()HC-A() ()-6()**

The high pitch stop is set at the factory per the aircraft manufacturer's recommendations. These stops are adjustable only by an appropriately licensed propeller repair facility or the Hartzell factory.

9. **Feathering Pitch Stop Settings**

- A. **Feathering Pitch Stop Adjustment - Propeller Models ()HC-A() ()-2() and ()HC-A() ()-5()**

The feathering pitch stop is set at the factory per the aircraft manufacturer's recommendations. This stop is adjustable only by an appropriately licensed propeller repair facility, aircraft manufacturer, or the Hartzell factory.

10. Start Lock Settings

- A. Start Lock Adjustment - Propeller Models
()HC-A()()-2() and ()HC-A()()-5()

The start locks are set at the factory per the aircraft manufacturer's recommendations. Start locks are adjustable only by an appropriately licensed propeller repair facility or at the Hartzell factory.

11. Propeller Ice Protection Systems

- A. Refer to the Anti-ice and De-ice Systems chapter of this manual for de-ice system maintenance information.

CONTENTS

1. Introduction.....	7-3
A. Propeller De-Ice System	7-3
B. Propeller Anti-Ice System.....	7-3
2. System Description.....	7-4
A. De-Ice System	7-4
B. Anti-Ice System.....	7-5
3. De-ice System Functional Tests	7-5
4. Anti-Ice System Functional Tests.....	7-5
A. Operational Check	7-5
5. De-Ice and Anti-Ice System Inspections.....	7-6
A. De-Ice System Inspections	7-6
B. Anti-Ice System Inspections.....	7-6
6. De-Ice and Anti-Ice System Troubleshooting	7-6
A. De-Ice System Troubleshooting.....	7-6
B. Anti-Ice System Troubleshooting	7-7

(This page is intentionally blank.)

1. Introduction**A. Propeller De-Ice System**

A propeller de-ice system is a system that removes ice after it forms on the propeller blades. A de-ice system uses electrical heating elements to melt the ice layer next to the blades, allowing the ice to be thrown from the blade by centrifugal force. Blades are alternately heated and allowed to cool as the current is applied and removed automatically by the de-ice system timer.

System components include a timer or cycling unit, electrical slip ring(s), brush block assembly, and blade mounted de-ice boots.

B. Propeller Anti-Ice System

A propeller anti-ice system is a system that prevents formation of ice on propeller surfaces. An anti-ice system dispenses a fluid that mixes with, and reduces the freezing point of, moisture on the propeller blades. The mixture may then flow off the blades before it forms ice.

System components include a fluid tank, pump, slinger ring, and blade mounted fluid feed shoes.

2. System Description

A. De-ice System

NOTE: Due to the wide variances of various de-ice systems, the following description is general in nature. Consult the airframe manufacturer's manual for a description of your specific de-ice system and controls.

The de-ice system is controlled by the pilot via a cockpit control switch. This switch applies electrical power to the de-ice system, which will operate as long as the switch is in the ON position. Depending upon the system, another set of cockpit controls may be available. One of these controls is a mode selector, which allows the pilot to select two cycling speeds, for heavy or light icing conditions. Some systems on twin engine aircraft have a switch which provides a full de-ice mode, which allows the pilot to de-ice both propellers simultaneously. This switch may only be used for short periods and is used when ice builds up on the propeller before the system is turned on.

An ammeter, which indicates current drawn by the system, is normally located near the de-ice system switches. This meter may indicate total system load, or a separate meter may be supplied for each propeller.

A timer, which is turned off and on by the cockpit control, is used to sequence the de-ice system. This timer turns the de-ice system on and off in proper sequence, controlling the heating interval for each propeller and ensuring even de-icing.

A brush block, which is mounted on the engine immediately behind the propeller, supplies electrical current to the de-ice boot on each propeller blade via a slip ring. The slip ring is normally mounted on the spinner bulkhead.

When the pilot places the de-ice system cockpit control switch in the ON position, system timer begins to operate. As the timer sequences, power is delivered to a power relay. The power relay delivers high current to the brush block and slip ring. Each propeller is de-iced in turn by the timer.

B. Anti-ice System

The anti-ice system is controlled by the pilot via a cockpit mounted rheostat. This rheostat operates a pump that pumps anti-ice fluid from the tank at a controlled rate.

The anti-ice fluid is delivered through a filter, a check valve, and then through tubing to a slinger ring located at the rear of the spinner bulkhead. The anti-ice fluid is dispensed into the rotating slinger ring, which holds the fluid in a curved channel by centrifugal force. The fluid then flows out of the slinger ring through feed tubes, which are welded to the slinger ring, and then out onto the blade anti-icing boots.

The blade anti-icing boots are ridged rubber sheets that are glued to the leading edge of the blades. The ridges in the shoes direct the fluid out onto the blades and permit an even distribution of the anti-ice fluid across the blades.

3. De-ice System Functional Tests

A. Functional tests of the de-ice system should be performed in accordance with the following Hartzell Manuals, which are available on the Hartzell Propeller website at www.hartzellprop.com:

- (1) Hartzell Manual 181 (30-60-81) - Propeller Ice Protection System Component Maintenance Manual
- (2) Hartzell Manual 182 (61-12-82) - Propeller Electrical De-ice Boot Removal and Installation Manual

4. Anti-ice System Functional Tests

A. Operational Checks of the anti-ice system should be performed in accordance with the following Hartzell Manuals, which are available on the Hartzell Propeller website at www.hartzellprop.com:

- (1) Hartzell Manual 181 (30-60-81) - Propeller Ice Protection System Component Maintenance Manual
- (2) Hartzell Manual 183 (61-12-83) - Propeller Anti-icing Boot Removal and Installation Manual

5. De-ice and Anti-ice System Inspections

The inspections detailed below are made on a regular basis, either before flight, during the 100 hour inspection, or if a problem is noted. Possible corrections to problems discovered during inspections, additional inspections, and limits are detailed in the following Hartzell manuals.

A. De-ice System Inspections

- (1) Perform inspections in accordance with the following Hartzell Manuals, which are available on the Hartzell Propeller website at www.hartzellprop.com:
 - (a) Hartzell Manual 181 (30-60-81) - Propeller Ice Protection System Component Maintenance Manual
 - (b) Hartzell Manual 182 (61-12-82) - Propeller Electrical De-ice Boot Removal and Installation Manual

B. Anti-ice System Inspections

- (1) Perform inspections in accordance with the following Hartzell Manuals, which are available on the Hartzell Propeller website at www.hartzellprop.com:
 - (a) Hartzell Manual 181 (30-60-81) - Propeller Ice Protection System Component Maintenance Manual
 - (b) Hartzell Manual 183 (61-12-83) - Propeller Anti-icing Boot Removal and Installation Manual

6. De-Ice and Anti-ice System Troubleshooting**A. De-Ice System Troubleshooting**

- (1) Perform troubleshooting in accordance with the following Hartzell Manuals, which are available on the Hartzell Propeller website at www.hartzellprop.com:
 - (a) Hartzell Manual 181 (30-60-81) - Propeller Ice Protection System Component Maintenance Manual
 - (b) Hartzell Manual 182 (61-12-82) - Propeller Electrical De-ice Boot Removal and Installation Manual

B. Anti-ice System Troubleshooting

- (1) Perform troubleshooting in accordance with the following Hartzell Manuals, which are available on the Hartzell Propeller website at www.hartzellprop.com:
 - (a) Hartzell Manual 181 (30-60-81) - Propeller Ice Protection System Component Maintenance Manual
 - (b) Hartzell Manual 183 (61-12-83) - Propeller Anti-icing Boot Removal and Installation Manual

(This page intentionally blank.)

CONTENTS

1. Introduction..... 8-3

2. Record Keeping..... 8-3

 A. Information to be Recorded 8-3

(This page is intentionally blank.)

1. Introduction

Federal Aviation Regulations require that a record be kept of any repairs, adjustments, maintenance, or required inspections performed on a propeller or propeller system.

This chapter provides a method for maintaining these records. It also provides a location for recording information that can aid the service technician in maintaining the propeller system.

2. Record Keeping**A. Information to be Recorded**

- (1) Information that is required to be recorded is listed in Part 43 of the U.S. Federal Aviation Regulations.
- (2) The log book may also be used to record:
 - (a) Propeller position (on aircraft)
 - (b) Propeller model
 - (c) Propeller serial number
 - (d) Blade design number
 - (e) Blade serial numbers
 - (f) Spinner assembly part number
 - (g) Propeller pitch range
 - (h) Aircraft information (aircraft type, model, serial number and registration number)

(This page is intentionally blank.)