

Manual No. 149
61-00-49
Revision 21
October 2015

Propeller Owner's Manual and Logbook

Models: HC-(D,E)4()-2()
HC-(D,E)4()-3()
HC-(D,E)4()-5()
HC-D3F-7()
HC-E5N-3()

Lightweight Turbine Propellers with Aluminum Blades

Hartzell Propeller Inc.
One Propeller Place
Piqua, OH 45356-2634 U.S.A.
Ph: 937-778-4200 (Hartzell Propeller Inc.)
Ph: 937-778-4379 (Product Support)
Product Support Fax: 937-778-4391

As a fellow pilot, I urge you to read this Manual thoroughly. It contains a wealth of information about your new propeller.

The propeller is among the most reliable components of your airplane. It is also among the most critical to flight safety. It therefore deserves the care and maintenance called for in this Manual. Please give it your attention, especially the section dealing with Inspections and Checks.

Thank you for choosing a Hartzell propeller. Properly maintained it will give you many years of reliable service.

A handwritten signature in black ink that reads "Jim Brown". The signature is fluid and cursive, with a long horizontal stroke extending to the right.

Jim Brown
Chairman, Hartzell Propeller Inc.

WARNING

People who fly should recognize that various types of risks are involved; and they should take all precautions to minimize them, since they cannot be eliminated entirely.

The propeller is a vital component of the aircraft. A mechanical failure of the propeller could cause a forced landing or create vibrations sufficiently severe to damage the aircraft, possibly causing it to become uncontrollable.

Propellers are subject to constant vibration stresses from the engine and airstream, which are added to high bending and centrifugal stresses.

Before a propeller is certified as being safe to operate on an airplane, an adequate margin of safety must be demonstrated. Even though every precaution is taken in the design and manufacture of a propeller, history has revealed rare instances of failures, particularly of the fatigue type.

It is essential that the propeller is properly maintained according to the recommended service procedures and a close watch is exercised to detect impending problems before they become serious. Any grease or oil leakage, loss of air pressure, unusual vibration, or unusual operation should be investigated and repaired, as it could be a warning that something serious is wrong.

For operators of uncertified or experimental aircraft an even greater level of vigilance is required in the maintenance and inspection of the propeller. Experimental installations often use propeller-engine combinations that have not been tested and approved. In these cases, the stress on the propeller and, therefore, its safety margin is unknown. Failure could be as severe as loss of propeller or propeller blades and cause loss of propeller control and/or loss of aircraft control.

Hartzell Propeller Inc. follows FAA regulations for propeller certification on certificated aircraft. Experimental aircraft may operate with unapproved engines or propellers or engine modifications to increase horsepower, such as unapproved crankshaft damper configurations or high compression pistons. These issues affect the vibration output of the engine and the stress levels on the propeller. Significant propeller life reduction and failure are real possibilities.

Frequent inspections are strongly recommended if operating with a non-certificated installation; however, these inspections may not guarantee propeller reliability, as a failing device may be hidden from the view of the inspector. Propeller overhaul is strongly recommended to accomplish periodic internal inspection.

Visually inspect metal blades for cracks. Inspect hubs, with particular emphasis on each blade arm for cracks. Eddy current equipment is recommended for hub inspection, since cracks are usually not apparent.

(This page is intentionally blank.)

REVISION HIGHLIGHTS

Revision 21, dated October 2015, incorporates the following:

- COVER
 - Revised to match the manual revision
- REVISION HIGHLIGHTS
 - Revised to match the manual revision
- LIST OF EFFECTIVE PAGES
 - Revised to match the manual revision
- TABLE OF CONTENTS
 - Revised to match the manual revision
- INTRODUCTION
 - Revised the section "Personnel Requirements"
 - Revised the section "Maintenance Practices"
 - Revised the section "Reference Publications"
- INSTALLATION AND REMOVAL
 - Revised the section "Tools, Consumables, and Expendables"
 - Revised Table 3-1, "Propeller/Engine Flange O-rings and Mounting Hardware"
 - Revised Table 3-2, "Torque Table"
 - Revised figure 3-6, Tool for Decompressing HC-(D,E)(4,5)()-3() Series External Beta System
 - Revised the section "Installing the HC-(D,E)(4,5)(A,N)-3() Propeller on the Aircraft Engine"
 - Added the section "Installing the HC-E4P-3K Propeller on the Aircraft Engine"
 - Revised the section "Post-Installation Checks"
 - Revised the section "Removal of HC-(D,E)(4,5)(A,N)-3() Propellers"
 - Added the section "Removal of HC-E4P-3K Propellers"

REVISION HIGHLIGHTS, continued

- INSPECTION AND CHECK
 - Revised Figure 5-3, "Turbine Engine Overspeed Limits"
 - Revised Figure 5-4, "Turbine Engine Overtorque Limits"
- MAINTENANCE PRACTICES
 - Revised the section "Lubrication Procedure"

REVISION HIGHLIGHTS**1. Introduction****A. General**

This is a list of current revisions that have been issued against this manual. Please compare it to the RECORD OF REVISIONS page to ensure that all revisions have been added to the manual.

B. Components

- (1) Revision No. indicates the revisions incorporated in this manual.
- (2) Issue Date is the date of the revision.
- (3) Comments indicates the level of the revision.
 - (a) New Issue is a new manual distribution. The manual is distributed in its entirety. All the page revision dates are the same and no change bars are used.
 - (b) Reissue is a revision to an existing manual that includes major content and/or major format changes. The manual is distributed in its entirety. All the page revision dates are the same and no change bars are used.
 - (c) Major Revision is a revision to an existing manual that includes major content or minor content changes over a large portion of the manual. The manual is distributed in its entirety. All the page revision dates are the same, but change bars are used to indicate the changes incorporated in the latest revision of the manual.
 - (d) Minor Revision is a revision to an existing manual that includes minor content changes to the manual. Only the revised pages of the manual are distributed. Each page retains the date and the change bars associated with the last revision to that page.

<u>Revision No.</u>	<u>Issue Date</u>	<u>Comments</u>
Revision 8	Nov/99	Reissue
Revision 9	July/03	Minor Revision
Revision 10	Sep/07	Minor Revision
Revision 11	Nov/09	Minor Revision
Revision 12	Apr/11	Minor Revision
Revision 13	Aug/12	Minor Revision
Revision 14	Nov/12	Minor Revision
Revision 15	Feb/13	Minor Revision
Revision 16	May/13	Minor Revision
Revision 17	Mar/14	Minor Revision
Revision 18	Apr/14	Minor Revision
Revision 19	May/14	Minor Revision
Revision 20	Dec/14	Minor Revision
Revision 21	Oct/15	Minor Revision

RECORD OF REVISIONS

This is a record of revisions inserted into this manual.
Revision 14 includes all prior revisions.

Rev. No.	Issue Date	Date Inserted	Inserted By
14	Nov/12	Nov/12	HPI
15	Feb/13	Feb/13	HPI
16	May/13	May/13	HPI
17	Mar/14	Mar/14	HPI
18	Apr/14	Apr/14	HPI
19	May/14	May/14	HPI
20	Dec/14	Dec/14	HPI
21	Oct/15	Oct/15	HPI

RECORD OF REVISIONS

This is a record of revisions inserted into this manual.
Revision 14 includes all prior revisions.

Rev. No.	Issue Date	Date Inserted	Inserted By

RECORD OF TEMPORARY REVISIONS

All Temporary Revisions are included in Revision 10, up to and including TR-002.

TR No.	Issue Date	Date Inserted	Inserted By	Date Removed	Removed By

RECORD OF TEMPORARY REVISIONS

All Temporary Revisions are included in Revision 10,
up to and including TR-002.

TR No.	Issue Date	Date Inserted	Inserted By	Date Removed	Removed By

SERVICE DOCUMENTS LIST

CAUTION 1: DO NOT USE OBSOLETE OR OUTDATED INFORMATION. PERFORM ALL INSPECTIONS OR WORK IN ACCORDANCE WITH THE MOST RECENT REVISION OF THE SERVICE DOCUMENT. INFORMATION CONTAINED IN A SERVICE DOCUMENT MAY BE SIGNIFICANTLY CHANGED FROM EARLIER REVISIONS. USE OF OBSOLETE INFORMATION MAY CREATE AN UNSAFE CONDITION THAT MAY RESULT IN DEATH, SERIOUS BODILY INJURY, AND/OR SUBSTANTIAL PROPERTY DAMAGE. REFER TO THE APPLICABLE SERVICE DOCUMENT INDEX FOR THE MOST RECENT REVISION LEVEL OF THE SERVICE DOCUMENT.

CAUTION 2: THE INFORMATION FOR THE DOCUMENTS LISTED INDICATES THE REVISION LEVEL AND DATE AT THE TIME THAT THE DOCUMENT WAS INITIALLY INCORPORATED INTO THIS MANUAL. INFORMATION CONTAINED IN A SERVICE DOCUMENT MAY BE SIGNIFICANTLY CHANGED FROM EARLIER REVISIONS. REFER TO THE APPLICABLE SERVICE DOCUMENT INDEX FOR THE MOST RECENT REVISION LEVEL OF THE SERVICE DOCUMENT.

Service Document Number	Incorporation Rev/Date
Service Bulletins:	
HC-SB-61-181A, Rev. 1	Rev. 10 Sep/07
HC-SB-61-181A, Rev. 4	Rev. 12 Apr/11
HC-SB-61-225, Rev. 3	Rev. 10 Sep/07
HC-SB-61-312	Rev. 11 Nov/09

SERVICE DOCUMENTS LIST

Service Document Number	Incorporation Rev/Date
Service Letters:	
HC-SL-61-184	Rev. 9 July/03
HC-SL-61-187, Rev. 1	Rev. 9 July/03
HC-SL-61-187, Rev. 2	Rev. 10 Sep/07
HC-SL-61-254	Rev. 10 Sep/07
HC-SL-61-321	Rev. 16 May/13
HC-SL-61-324	Rev. 13 Aug/12

AIRWORTHINESS LIMITATIONS

The Airworthiness Limitations section is FAA approved and specifies maintenance required under 14 CFR §§ 43.16 and 91.403 of the Federal Aviation Regulations unless an alternative program has been FAA approved.

FAA APPROVED

 by:  date: 12/18/14

Manager, Chicago Aircraft Certification Office,
ACE-115C
Federal Aviation Administration

Rev. No.	Description of Revision
11	Added airworthiness limitation information from Hartzell Propeller Inc. Overhaul Manual 141 (61-10-41), Hartzell Propeller Inc. Overhaul Manual 142 (61-10-42), and Hartzell Propeller Inc. Overhaul Manual 158A (61-10-58). Added hub unit limits and revised blade life limits for propeller model HC-D4N-5(C,E)/D9327K. Removed hub life limit and inspection for propeller model HC-E4W-5L/JE10305(B).
14	Added a hub unit life limit and a blade life limit for propeller model HC-E4A-2/E9673S
16	Added a blade life limit for propeller model HC-E4N-2D/E9512G(B)-1, removed the inspection requirement for propeller model HC-E4W-5L/JE10305(B)
18	Added a blade life limit and a hub unit life limit for propeller model HC-E5N-3A(L)/(H,L)E8492
20	Added additional Engine Exhaust Stubs for the HC-E5N-3(A)/HE8218 and the HC-E5N-3(A)/LE8218 propellers installed on the Piaggio P180.

AIRWORTHINESS LIMITATIONS

1. Replacement Time (Life Limits)
 - A. The FAA establishes specific life limits for certain component parts, as well as the entire propeller. Such limits require replacement of the identified parts after a specified number of hours of use.
 - B. The following data summarizes all current information concerning Hartzell Propeller Inc. life limited parts as related to propeller models affected by this manual. These parts are not life limited on other installations; however, time accumulated toward life limit accrues when first operated on aircraft/engine/propeller combinations listed, and continues regardless of subsequent installations (which may or may not be life limited).

FAA APPROVED

by:  _____ date: 12/18/14

605
Manager, Chicago Aircraft Certification Office,
ACE-115C
Federal Aviation Administration

AIRWORTHINESS LIMITATIONS

- (1) The following list specifies life limits for blades only. Associated hub parts are not affected. Blade models shown are life limited only on the specified applications.

PROPELLER MODELS ON FAA TYPE CERTIFIED AIRCRAFT	
Aircraft/Engine/Propeller	Blade Life Limit
Aircraft: Hawker Beechcraft Model 3000 (US Military T-6A) Engine: Pratt & Whitney Model PT6A-68 Propeller: HC-E4A-2(A)/E9612(K)	19,497 hours
Aircraft: Hawker Beechcraft Model 3000 (US Military T-6A) Engine: Pratt & Whitney Model PT6A-68 Propeller: HC-E4A-2(A)/E9612(K)	19,497 hours
Aircraft: Hawker Beechcraft Model AT-6 Engine: Pratt & Whitney Model PT6A-68D Propeller: HC-E4A-2/E9673S	7,400 hours
Aircraft: Shorts Model T Mk 1 Tucano Engine: Honeywell (Garrett) Model TPE331-12B Propeller: HC-D4N-5(C,E)/D9327K	41,300 hours

FAA APPROVED

by:  date: 12/18/14

for
 Manager, Chicago Aircraft Certification Office,
 ACE-115C
 Federal Aviation Administration

AIRWORTHINESS LIMITATIONS

PROPELLER MODELS ON FAA TYPE CERTIFIED AIRCRAFT, CONTINUED											
Aircraft/Engine/Propeller	Blade Life Limit										
Aircraft: Piaggio P-180 Avanti that uses nacelles 80-336005-801 /80-336006-801 and exhaust stub 80-336013-801 Engine: Pratt & Whitney Model PT6A-66 Propeller: HC-E5N-3(A) (L)/(H,L)E8218	1,500 hours (For complete life limit criteria, refer to paragraph 2 in this section.)										
Aircraft: Piaggio P-180 Avanti that uses nacelles 80-336213-801 /80-336214-801 and exhaust stub 80-336013-801 Engine: Pratt & Whitney Model PT6A-66 Propeller: HC-E5N-3(A) (L)/(H,L)E8218	3,000 hours (For complete life limit criteria, refer to paragraph 2 in this section.)										
Aircraft: Piaggio P-180 Avanti that uses the following: <table border="0"><tr><td><u>L/H Aft Nacelle/R/H Aft Nacelle</u></td><td><u>Exhaust Stub</u></td></tr><tr><td>80-336213-803/80-336214-803</td><td>80-336013-803 or 80-336091-801</td></tr><tr><td>80-336213-805/80-336214-805</td><td>80-337984-801</td></tr><tr><td>80-336250-801/80-336251-801</td><td>80-336013-803 or 80-336091-801</td></tr><tr><td>80-336250-803/80-336251-803</td><td>80-336013-803 or 80-336091-801</td></tr></table> Engine: Pratt & Whitney Model PT6A-66(B) Propeller: HC-E5N-3(A) (L)/(H,L)E8218	<u>L/H Aft Nacelle/R/H Aft Nacelle</u>	<u>Exhaust Stub</u>	80-336213-803/80-336214-803	80-336013-803 or 80-336091-801	80-336213-805/80-336214-805	80-337984-801	80-336250-801/80-336251-801	80-336013-803 or 80-336091-801	80-336250-803/80-336251-803	80-336013-803 or 80-336091-801	9,000 hours (For complete life limit criteria, refer to paragraph 2 in this section.)
<u>L/H Aft Nacelle/R/H Aft Nacelle</u>	<u>Exhaust Stub</u>										
80-336213-803/80-336214-803	80-336013-803 or 80-336091-801										
80-336213-805/80-336214-805	80-337984-801										
80-336250-801/80-336251-801	80-336013-803 or 80-336091-801										
80-336250-803/80-336251-803	80-336013-803 or 80-336091-801										
Aircraft: Piaggio Aero Industries P-180 that uses rear nacelle 81-336033-801 and engine exhaust duct 81-336035-801 Engine: Pratt & Whitney Model PT6A-66B Propeller: HC-E5N-3A(L)/(H,L)E8492	9,000 hours										

FAA APPROVED

by:  date: 12/18/14

for
Manager, Chicago Aircraft Certification Office,
ACE-115C
Federal Aviation Administration

AIRWORTHINESS LIMITATIONS

PROPELLER MODELS ON AIRCRAFT WITHOUT AN FAA TYPE CERTIFICATE	
Aircraft/Engine/Propeller	Blade Life Limit
Aircraft: Pilatus Model PC-9 Engine: Pratt & Whitney Model PT6A-62B Propeller: HC-D4N-2AA/D9512AE(K)	9,000 hours
Aircraft: Pilatus Model PC-9 Engine: Pratt & Whitney Model PT6A-62B Propeller: HC-D4N-2G/D9512AE(K)	9,000 hours
Aircraft: Pilatus Model PC7 MK II Engine: Pratt & Whitney Model PT6A-25C Propeller: HC-D4N-2D/D9512A(K)	11,500 hours
Aircraft: Pilatus Model PC7 MK II Engine: Pratt & Whitney Model PT6A-25C Propeller: HC-D4N-2E/D9512A(K)	11,500 hours
Aircraft: Pilatus Model PC-9 Engine: Pratt & Whitney Model PT6A-62 Propeller: HC-D4N-2A/D9512A(B,K)	11,500 hours
Aircraft: Pilatus Model PC-9 Engine: Pratt & Whitney Model PT6A-62 Propeller: HC-D4N-2F/D9512A(B,K)	11,500 hours

FAA APPROVED

by:  date: 12/18/14

for
 Manager, Chicago Aircraft Certification Office,
 ACE-115C
 Federal Aviation Administration

AIRWORTHINESS LIMITATIONS

PROPELLER MODELS ON AIRCRAFT WITHOUT AN FAA TYPE CERTIFICATE, CONTINUED	
Aircraft/Engine/Propeller	Blade Life Limit
Aircraft: Korea Aerospace Industries Engine: Pratt & Whitney Model PT6A-62 Propeller: HC-E4N-2/E9512CB-1	7,100 hours
Aircraft: Korea Aerospace Industries KO-1 Engine: Pratt & Whitney Model PT6A-62 Propeller: HC-E4N-2B/E9512DB-1	7,600 hours
Aircraft: Korea Aerospace Industries KT-1C and KT-1T Engine: Pratt & Whitney Model PT6A-62 Propeller: HC-E4N-2C/E9512CB-1	7,100 hours
Aircraft: Korea Aerospace Industries KT-1P Engine: Pratt & Whitney Model PT6A-62 Propeller: HC-E4N-2D/E9512G(B)-1	7,100 hours
Aircraft: EADS-PZL Warszawa Okecie PZL-130TCII Engine: Pratt & Whitney Model PT6A-25C Propeller: HC-D4N-2DA/D9512AF	32,500 hours

FAA APPROVED

by: 

date: 12/18/14

for
Manager, Chicago Aircraft Certification Office,
ACE-115C
Federal Aviation Administration

AIRWORTHINESS LIMITATIONS

- (2) The following list specifies life limits for propeller hubs only. Hubs listed are life limited only on the specified applications.

PROPELLER MODELS ON FAA TYPE CERTIFIED AIRCRAFT	
Aircraft/Engine/Propeller	Hub Unit Life Limit
Aircraft: Hawker Beechcraft Model 3000 (US Military T-6A) Engine: Pratt & Whitney Model PT6A-68 Propeller: HC-E4A-2(A)/E9612(K)	19,497 hours
Aircraft: Hawker Beechcraft Model 3000 IAUP (US Military T-6B) Engine: Pratt & Whitney Model PT6A-68 Propeller: HC-E4A-2(A)/E9612(K)	19,497 hours
Aircraft: Hawker Beechcraft Model AT-6 Engine: Pratt & Whitney Model PT6A-68D Propeller: HC-E4A-2/E9673S	19,497 hours
Aircraft: Shorts Model T Mk 1 Tucano Engine: Honeywell (Garrett) Model TPE331-12B Propeller: HC-D4N-5(C,E)/D9327K	59,600 hours

FAA APPROVED

by:  date: 12/18/14

for
Manager, Chicago Aircraft Certification Office,
ACE-115C
Federal Aviation Administration

AIRWORTHINESS LIMITATIONS

PROPELLER MODELS ON FAA TYPE CERTIFIED AIRCRAFT, CONTINUED	
Aircraft/Engine/Propeller	Hub Life Limit
Aircraft: Piaggio P-180 Avanti that uses nacelles 80-336005-801 /80-336006-801 and exhaust stub 80-336013-801 Engine: Pratt & Whitney Model PT6A-66 Propeller: HC-E5N-3(A) (L)/(H,L)E8218	1,500 hours (For complete life limit criteria, refer to paragraph 2 in this section.)
Aircraft: Piaggio P-180 Avanti that uses nacelles 80-336213-801 /80-336214-801 and exhaust stub 80-336013-801 Engine: Pratt & Whitney Model PT6A-66 Propeller: HC-E5N-3(A) (L)/(H,L)E8218	3,000 hours (For complete life limit criteria, refer to paragraph 2 in this section.)
Aircraft: Piaggio P-180 Avanti that uses the following: <u>L/H Aft Nacelle/R/H Aft Nacelle Exhaust Stub</u> 80-336213-803/80-336214-803 80-336013-803 or 80-336091-801 80-336213-805/80-336214-805 80-337984-801 80-336250-801/80-336251-801 80-336013-803 or 80-336091-801 80-336250-803/80-336251-803 80-336013-803 or 80-336091-801 Engine: Pratt & Whitney Model PT6A-66 Propeller: HC-E5N-3(A) (L)/(H,L)E8218	18,000 hours (For complete life limit criteria, refer to paragraph 2 in this section.)
Aircraft: Piaggio Aero Industries P-180 that uses rear nacelle 81-336033-801 and engine exhaust duct 81-336035-801 Engine: Pratt & Whitney Model PT6A-66B Propeller: HC-E5N-3A(L)/(H,L)E8492	14,800 hours

FAA APPROVED

by:  date: 12/18/14

for
Manager, Chicago Aircraft Certification Office,
ACE-115C
Federal Aviation Administration

AIRWORTHINESS LIMITATIONS

PROPELLER MODELS ON AIRCRAFT WITHOUT AN FAA TYPE CERTIFICATE	
Aircraft/Engine/Propeller	Hub Life Limit
Aircraft: EADS-PZL Warszawa Okecie PZL-130TCII Engine: Pratt & Whitney Model PT6A-25C Propeller: HC-D4N-2DA/D9512AF	5,500 hours

FAA APPROVED

by:  date: 12/18/14

for
Manager, Chicago Aircraft Certification Office,
ACE-115C
Federal Aviation Administration

AIRWORTHINESS LIMITATIONS

2. HC-E5N-3(A)(L)/(H,L)E8218

- A. Propeller hub and blades of HC-E5N-3() (), for Piaggio P-180 aircraft with Pratt & Whitney PT6A-66 engines, are life limited at 1500 hours and must be retired from service if they have ever been installed on an aircraft with nacelle p/n 80-336005-801 and 80-336006-801 and exhaust stub p/n 80-336013-801 before incorporation of Piaggio Service Bulletin SB-80-0022.
- B. Propeller hub and blades of HC-E5N-3() (), for Piaggio P-180 aircraft with Pratt & Whitney PT6A-66 engines, are life limited at 3000 hours and must be retired from service if they have ever been installed on an aircraft with nacelle p/n 80-336213-801 and 80-336214-801 and exhaust stub p/n 80-336013-801 before incorporation of Piaggio Service Bulletin SB-80-0022.
- C. Propeller hub of HC-E5N-3() (), for Piaggio P-180 aircraft with Pratt & Whitney PT6A-66(B) engines, is life limited at 18,000 hours and must be retired from service if it has been installed on an aircraft since new with:
 - 1) Nacelle p/n 80-336213-803 and 80-336214-803 and exhaust stub p/n 80-336013-803 or 80-336091-801; or
 - 2) Nacelle p/n 80-336213-805 and 80-336214-805 and exhaust stub p/n 80-337984-801; or
 - 3) Nacelle p/n 80-336250-801 and 80-336251-801 and exhaust stub p/n 80-336013-803 or 80-336091-801; or
 - 4) Nacelle p/n 80-336250-803 and 80-336251-803 and exhaust stub p/n 80-336013-803 or 80-336091-801; or
 - 5) Incorporates Piaggio Service Bulletin SB-80-0022 since new.

Any propeller that was operated on an aircraft before incorporation of SB-80-0022 is not eligible for the 18,000 hour hub service life.

FAA APPROVED

by:  date: 12/18/14

for

Manager, Chicago Aircraft Certification Office,
ACE-115C
Federal Aviation Administration

AIRWORTHINESS LIMITATIONS

D. Propeller blades of HC-E5N-3() (), for Piaggio P-180 aircraft with Pratt & Whitney PT6A-66(B) engines, are life limited at 9000 hours and must be retired from service if they have been installed on an aircraft since new with:

- 1) Nacelle p/n 80-336213-803 and 80-336214-803 and exhaust stub p/n 80-336013-803 or 80-336091-801; or
- 2) Nacelle p/n 80-336213-805 and 80-336214-805 and exhaust stub p/n 80-337984-801; or
- 3) Nacelle p/n 80-336250-801 and 80-336251-801 and exhaust stub p/n 80-336013-803 or 80-336091-801; or
- 4) Nacelle p/n 80-336250-803 and 80-336251-803 and exhaust stub p/n 80-336013-803 or 80-336091-801; or
- 5) Incorporates Piaggio Service Bulletin SB-80-0022 since new.

Any propeller that was operated on an aircraft before incorporation of SB-80-0022 is not eligible for the 9000 hour blade service life.

FAA APPROVED

by:  date: 12/18/14

for
Manager, Chicago Aircraft Certification Office,
ACE-115C
Federal Aviation Administration

AIRWORTHINESS LIMITATIONS

3. Periodic Inspections

- A. For propeller model HC-E5N-3(A)(L)/(H,L)E8218 used on Piaggio P-180 aircraft with Pratt & Whitney PT6A-66 engines:
 - (1) Beginning with an inspection at 1500 hours time in service, propeller blades that have part numbers HE8218 and LE8218, must be inspected for corrosion/paint every 24 months or 600 hours of operation, whichever occurs first, in accordance with Hartzell Propeller Inc. Service Bulletin HC-SB-61-181A.
- B. For propeller model HC-E5N-3A(L)/(H,L)E8492 used on Piaggio P-180 aircraft with Pratt & Whitney PT6A-66 engines:
 - (1) Propeller blade corrosion/paint inspections must be performed at regular intervals as specified in Hartzell Propeller Inc. Service Bulletin HC-SB-61-181A.

FAA APPROVED

by: 

date: 12/18/14

for

Manager, Chicago Aircraft Certification Office,
ACE-115C
Federal Aviation Administration

LIST OF EFFECTIVE PAGES

Chapter	Page	Revision	Date
Cover	Cover and Inside Cover	Rev. 21	Oct/15
Message	1	Rev. 8	Nov/99
Message	2 thru 4	Rev. 10	Sep/07
Revision Highlights	5 thru 8	Rev. 21	Oct/15
Record of Revisions	9 and 10	Rev. 14	Nov/12
Record of Temporary Revisions	11 and 12	Rev. 10	Sep/07
Service Documents List	13	Rev. 14	Nov/12
Service Documents List	14	Rev. 16	May/13
Airworthiness Limitations	15 thru 26	Rev. 20	Dec/14
List of Effective Pages	27 thru 30	Rev. 21	Oct/15
Table of Contents	31 thru 33	Rev. 21	Oct/15
Table of Contents	34 thru 36	Rev. 16	May/13
Table of Contents	37 and 38	Rev. 21	Oct/15
Introduction	1-1 and 1-2	Rev. 21	Oct/15
Introduction	1-3 and 1-4	Rev. 14	Nov/12
Introduction	1-5	Rev. 10	Sep/07
Introduction	1-6 thru 1-18	Rev. 21	Oct/15
Description and Operation	2-1 and 2-2	Rev. 21	Oct/15
Description and Operation	2-3 thru 2-6	Rev. 8	Nov/99
Description and Operation	2-7	Rev. 10	Sep/07
Description and Operation	2-8 and 2-9	Rev. 8	Nov/99
Description and Operation	2-10	Rev. 21	Oct/15
Description and Operation	2-10.1 and 2-10.2	Rev. 21	Oct/15
Description and Operation	2-11 and 2-12	Rev. 8	Nov/99
Description and Operation	2-13 and 2-14	Rev. 10	Sep/07
Description and Operation	2-14.1 and 2-14.2	Rev. 21	Oct/15
Description and Operation	2-15 and 2-16	Rev. 8	Nov/99
Description and Operation	2-17	Rev. 10	Sep/07
Description and Operation	2-18 thru 2-21	Rev. 15	Feb/13
Description and Operation	2-22 and 2-23	Rev. 17	Mar/14

LIST OF EFFECTIVE PAGES

Chapter	Page	Revision	Date
Description and Operation	2-24	Rev. 16	May/13
Description and Operation	2-25 thru 2-27	Rev. 15	Feb/13
Description and Operation	2-28 thru 2-30	Rev. 16	May/13
Installation and Removal	3-1 thru 3-6	Rev. 21	Oct/15
Installation and Removal	3-7	Rev. 13	Aug/12
Installation and Removal	3-8	Rev. 10	Sep/07
Installation and Removal	3-9 and 3-10	Rev. 21	Oct/15
Installation and Removal	3-11	Rev. 13	Aug/12
Installation and Removal	3-12	Rev. 10	Sep/07
Installation and Removal	3-13	Rev. 13	Aug/12
Installation and Removal	3-14 and 3-15	Rev. 10	Sep/07
Installation and Removal	3-16	Rev. 21	Oct/15
Installation and Removal	3-17	Rev. 13	Aug/12
Installation and Removal	3-18 and 3-19	Rev. 10	Sep/07
Installation and Removal	3-20 and 3-21	Rev. 21	Oct/15
Installation and Removal	3-22	Rev. 12	Apr/11
Installation and Removal	3-23	Rev. 21	Oct/15
Installation and Removal	3-24	Rev. 13	Aug/12
Installation and Removal	3-24.1	Rev. 13	Aug/12
Installation and Removal	3-24.2 thru 3-24.6	Rev. 21	Oct/15
Installation and Removal	3-25	Rev. 17	Mar/14
Installation and Removal	3-26 and 3-27	Rev. 13	Aug/12
Installation and Removal	3-28	Rev. 17	Mar/14
Installation and Removal	3-29	Rev. 21	Oct/15
Installation and Removal	3-30	Rev. 12	Apr/11
Installation and Removal	3-31	Rev. 13	Aug/12
Installation and Removal	3-32 and 3-33	Rev. 10	Sep/07
Installation and Removal	3-34	Rev. 13	Aug/12
Installation and Removal	3-35	Rev. 21	Oct/15
Installation and Removal	3-36 and 3-37	Rev. 13	Aug/12

LIST OF EFFECTIVE PAGES

Chapter	Page	Revision	Date
Installation and Removal	3-38	Rev. 21	Oct/15
Installation and Removal	3-39	Rev. 13	Aug/12
Installation and Removal	3-40 thru 3-43	Rev. 10	Sep/07
Installation and Removal	3-44 thru 3-49	Rev. 13	Aug/12
Installation and Removal	3-50 and 3-51	Rev. 10	Sep/07
Installation and Removal	3-52	Rev. 19	May/14
Installation and Removal	3-52.1 and 3-52.2	Rev. 19	May/14
Installation and Removal	3-53	Rev. 19	May/14
Installation and Removal	3-54	Rev. 10	Sep/07
Installation and Removal	3-55	Rev. 15	Feb/13
Installation and Removal	3-56	Rev. 21	Oct/15
Installation and Removal	3-57 thru 3-59	Rev. 13	Aug/12
Installation and Removal	3-60	Rev. 21	Oct/15
Installation and Removal	3-61 and 3-62	Rev. 13	Aug/12
Installation and Removal	3-62.1 thru 3-62.4	Rev. 21	Oct/15
Installation and Removal	3-63	Rev. 17	Mar/14
Installation and Removal	3-64 thru 3-74	Rev. 13	Aug/12
Installation and Removal	3-75 and 3-76	Rev. 15	Feb/13
Testing and Troubleshooting	4-1	Rev. 13	Aug/12
Testing and Troubleshooting	4-2	Rev. 10	Sep/07
Testing and Troubleshooting	4-3	Rev. 13	Aug/12
Testing and Troubleshooting	4-4	Rev. 16	May/13
Testing and Troubleshooting	4-4.1 and 4-4.2	Rev. 16	May/13
Testing and Troubleshooting	4-5 thru 4-7	Rev. 13	Aug/12
Testing and Troubleshooting	4-8 thru 4-12	Rev. 10	Sep/07
Inspection and Check	5-1	Rev. 16	May/13
Inspection and Check	5-2	Rev. 10	Sep/07
Inspection and Check	5-3 thru 5-11	Rev. 13	Aug/12
Inspection and Check	5-12	Rev. 10	Sep/07

LIST OF EFFECTIVE PAGES

Chapter	Page	Revision	Date
Inspection and Check	5-13	Rev. 13	Aug/12
Inspection and Check	5-14 and 5-15	Rev. 10	Sep/07
Inspection and Check	5-16 thru 5-18	Rev. 13	Aug/12
Inspection and Check	5-19 thru 5-24	Rev. 10	Sep/07
Inspection and Check	5-25	Rev. 12	Apr/11
Inspection and Check	5-26	Rev. 10	Sep/07
Inspection and Check	5-27	Rev. 11	Nov/09
Inspection and Check	5-28	Rev. 15	Feb/13
Inspection and Check	5-28.1 thru 5-28.4	Rev. 16	May/13
Inspection and Check	5-29	Rev. 16	May/13
Inspection and Check	5-30 and 5-31	Rev. 21	Oct/15
Inspection and Check	5-32 thru 5-34	Rev. 13	Aug/12
Inspection and Check	5-35 and 5-36	Rev. 10	Sep/07
Inspection and Check	5-37 and 5-38	Rev. 13	Aug/12
Inspection and Check	5-39 and 5-40	Rev. 10	Sep/07
Inspection and Check	5-41 and 5-42	Rev. 13	Aug/12
Maintenance Practices	6-1	Rev. 16	May/13
Maintenance Practices	6-2 and 6-3	Rev. 13	Aug/12
Maintenance Practices	6-4	Rev. 10	Sep/07
Maintenance Practices	6-5 and 6-6	Rev. 13	Aug/12
Maintenance Practices	6-7 thru 6-9	Rev. 21	Oct/15
Maintenance Practices	6-10	Rev. 19	May/14
Maintenance Practices	6-11 thru 6-16	Rev. 13	Aug/12
Maintenance Practices	6-17	Rev. 10	Sep/07
Maintenance Practices	6-18 thru 6-20	Rev. 13	Aug/12
Maintenance Practices	6-21	Rev. 21	Oct/15
Maintenance Practices	6-22	Rev. 16	May/13
Anti-ice and De-ice Systems	7-1 thru 7-8	Rev. 16	May/13
Records	8-1 thru 8-4	Rev. 10	Sep/07

TABLE OF CONTENTS

	<u>Page</u>
MESSAGE.....	1
REVISION HIGHLIGHTS	5
RECORD OF REVISIONS	9
RECORD OF TEMPORARY REVISIONS.....	11
SERVICE DOCUMENTS LIST	13
AIRWORTHINESS LIMITATIONS	15
LIST OF EFFECTIVE PAGES	27
TABLE OF CONTENTS.....	29
INTRODUCTION	1-1
1. Purpose	1-3
2. Airworthiness Limits.....	1-3
3. Airframe or Engine Modifications.....	1-4
4. Restrictions and Placards.....	1-5
5. General.....	1-6
A. Personnel Requirements	1-6
B. Maintenance Practices.....	1-6
C. Continued Airworthiness	1-9
D. Propeller Critical Parts	1-9
6. Reference Publications.....	1-10
7. Definitions.....	1-11
8. Abbreviations	1-15
9. Hartzell Propeller Inc. Product Support	1-16
10. Warranty Service	1-16
11. Hartzell Recommended Facilities	1-17
DESCRIPTION AND OPERATION	2-1
1. Functional Description of Constant Speed Propeller Types ...	2-5
A. Feathering Propellers HC-(D,E)4()-2() Series.....	2-5
B. Feathering and Reversing Propellers HC-(D,E)(4,5)()-3() Series.....	2-11
C. Feathering and Reversing Propellers HC-(D,E)4()-5() Series	2-15
D. Feathering and Reversing Propellers HC-D3F-7() Series	2-20

TABLE OF CONTENTS, CONTINUED

	<u>Page</u>
2. Model Designation	2-22
A. Aluminum Hub Propeller Model Identification	2-22
B. Aluminum Blade Model Identification	2-24
3. Governors	2-27
A. Theory of Operation	2-27
4. Propeller Ice Protection Systems	2-28
A. Propeller Anti-ice System	2-28
B. Propeller De-ice System	2-29
INSTALLATION AND REMOVAL	3-1
1. Tools, Consumables, and Expendables	3-5
A. General	3-5
B. Tooling	3-5
C. Consumables	3-6
D. Expendables	3-6
2. Pre-Installation	3-6
A. Inspection of Shipping Package	3-6
B. Uncrating	3-6
C. Inspection after Shipment	3-6
D. Reassembly of a Propeller Disassembled for Shipment ...	3-6
3. Propeller Assembly Installation	3-7
A. Precautions	3-7
B. Installing the HC-(D,E)4()-2() Propeller on the Aircraft Engine	3-11
C. Installing the HC-(D,E)(4,5)(A,N)-3() Propeller on the Aircraft Engine	3-21
C1. Installing the HC-E4P-3K Propeller on the Aircraft Engine	3-24.2
D. Installing the HC-E4W-3() Propeller on the Aircraft Engine	3-25
E. Installing the HC-E4W-5L Propeller on the Aircraft Engine	3-33
F. Installing the HC-(D,E)4()-5() Propeller on the Aircraft Engine, Except HC-E4W-5L	3-37
G. Installing the HC-D3F-7() Propeller on the Allison Engine	3-44

TABLE OF CONTENTS, CONTINUED

	<u>Page</u>
4. Spinner Dome Installation	3-52.1
A. General	3-52.1
B. Propeller Models HC-(D,E)4()-(2,3,5)(), HC-E5N-3(), and HC-D3F-7H That Use a One-piece Spinner Dome and Forward Bulkhead.....	3-52.1
C. Propeller Models HC-E5N-3() with D-5527-1() Spinner Assembly	3-55
D. Propeller Model HC-D3F-7 Installed on Goodyear Airship GZ-22	3-55
5. Post-Installation Checks	3-56
6. Spinner Dome Removal	3-56
7. Propeller Assembly Removal.....	3-57
A. Removal of HC-(D,E)4()-2() Propellers	3-57
B. Removal of HC-(D,E)(4,5)(A,N)-3() Propellers.....	3-60
B1. Removal of HC-E4P-3K Propellers	3-62.1
C. Removal of HC-E4W-3() Propellers	3-63
D. Removal of HC-E4W-5L Propellers	3-66
E. Removal of HC-(D,E)4()-5() Propellers, Except E4W-5L .	3-69
F. Removal of HC-D3F-7() Propellers	3-72
G. Removal of the D-751-() Beta Valve Assembly	3-75
TESTING AND TROUBLESHOOTING	4-1
1. Operational Tests.....	4-3
A. Initial Run-Up	4-3
B. Post-Run Check.....	4-3
C. Maximum RPM (Static) Hydraulic Low Pitch Stop Check .	4-4
D. Reverse Pitch Stop Adjustment	4-4
E. Feathering Pitch Stop Adjustment.....	4-4
F. Start Lock Adjustment	4-4
G. Propeller Ice Protection System.....	4-4
2. Troubleshooting	4-5
A. Hunting and Surging	4-5
B. Engine Speed Varies with Flight Altitude (or Airspeed).....	4-5
C. Loss of Propeller Control	4-6
D. Failure to Feather (or feathers slowly)	4-7

TABLE OF CONTENTS, CONTINUED

	<u>Page</u>
2. Troubleshooting, continued	
E. Failure to Unfeather	4-7
F. Start Locks (Anti-Feather Latches) Fail to Latch on Shutdown	4-7
G. Vibration	4-8
H. Propeller Overspeed	4-9
I. Propeller Underspeed	4-9
J. Oil or Grease Leakage	4-10
INSPECTION AND CHECK	5-1
1. Pre-Flight Checks	5-3
2. Operational Checks	5-5
3. Post-Flight Checks	5-6
A. General	5-6
B. Requirements	5-6
4. Required Periodic Inspections and Maintenance	5-7
A. Periodic Inspections	5-7
B. Periodic Maintenance	5-9
C. Airworthiness Limitations	5-9
D. Overhaul Periods	5-10
5. Inspection Procedures	5-18
A. Blade Damage	5-18
B. Grease or Oil Leakage	5-18
C. Vibration	5-20
D. Tachometer Inspection	5-23
E. Blade Track	5-25
F. Loose Blades	5-27
G. Preload Plate Set Screw	5-28
H. Corrosion	5-28.1
I. Spinner Damage	5-28.1
J. Electric De-ice System	5-28.1
K. Anti-ice System	5-28.1
L. UID Plate Inspection	5-28.1

TABLE OF CONTENTS, CONTINUED

	<u>Page</u>
6. Special Inspections.....	5-32
A. Overspeed/Overtorque	5-32
B. Propeller Ground Idle Operating Restrictions	5-33
C. Lightning Strike	5-39
D. Foreign Object Strike/Ground Strike	5-40
E. Fire Damage or Heat Damage	5-42
7. Long Term Storage	5-42
MAINTENANCE PRACTICES	6-1
1. Cleaning	6-3
A. General Cleaning	6-3
B. Spinner Cleaning and Polishing	6-5
2. Lubrication	6-5
A. Lubrication Intervals.....	6-5
B. Lubrication Procedure	6-6
C. Approved Lubricants.....	6-9
3. Carbon Block Assemblies	6-10
A. Inspection.....	6-10
B. Replacement of the A-3026 Carbon Block Unit in the A-3044 Carbon Block Assembly	6-10
C. Installation of the A-3044 Carbon Block Assembly	6-12
4. Blade Repairs	6-12
A. Repair of Nicks and Gouges	6-13
B. Repair of Bent Blades	6-14
5. Painting After Repair.....	6-15
A. General	6-15
B. Painting of Aluminum Blades	6-16
6. Dynamic Balance.....	6-18
A. Overview	6-18
B. Inspection Procedures Before Balancing.....	6-19
C. Modifying Spinner Bulkhead to Accommodate Dynamic Balance Weights	6-20
D. Placement of Balance Weights for Dynamic Balance	6-20

TABLE OF CONTENTS, CONTINUED

	<u>Page</u>
7. Propeller Ice Protection Systems	6-22
A. Electric De-ice System	6-22
B. Anti-ice System	6-22
ANTI-ICE AND DE-ICE SYSTEMS	7-1
1. Introduction	7-3
A. Propeller De-ice System	7-3
B. Anti-ice System	7-3
2. System Description	7-4
A. De-ice System	7-4
B. Anti-ice System	7-5
3. De-ice System Functional Tests	7-5
4. Anti-ice System Functional Tests	7-5
5. De-ice and Anti-ice System Inspections	7-6
A. De-ice System Inspections	7-6
B. Anti-ice System Inspections	7-6
6. De-ice and Anti-ice System Troubleshooting	7-7
A. De-ice System Troubleshooting	7-7
B. Anti-ice System Troubleshooting	7-7
RECORDS	8-1
1. Introduction	8-3
2. Record Keeping	8-3
A. Information to be Recorded	8-3

LIST OF FIGURES

	<u>Page</u>
HC-(D,E)4A-2() Series Propeller	Figure 2-1 2-3
HC-(D,E)4N-2() Series Propeller	Figure 2-2 2-4
HC-(D,E)4N-3() Series Propeller with Start Locks	Figure 2-3 2-7
HC-(D,E)4N-3() Series Propeller	Figure 2-4 2-8
HC-(D,E)4A-3() Series Propeller	Figure 2-5 2-9
HC-E4P-3K Series Propeller	Figure 2-5.1 2-10

LIST OF FIGURES, CONTINUED

	<u>Page</u>
HC-E4W-3() Series Propeller	Figure 2-5.2 2-10.1
HC-(D,E)5()-3() Series Propeller	Figure 2-6..... 2-10.2
HC-(D,E)4()-5() Series Propeller	Figure 2-7..... 2-14
HC-E4W-5() Series Propeller	Figure 2-7.1..... 2-14.1
HC-D3F-7 Series Propeller.....	Figure 2-8..... 2-18
HC-D3F-7H Series Propeller	Figure 2-9..... 2-19
Governor in Onspeed Condition	Figure 2-10..... 2-26
Governor in Underspeed Condition	Figure 2-11 2-26
Governor in Overspeed Condition	Figure 2-12..... 2-26
Air Conditioning Drive Accessories.....	Figure 3-1 3-8
Installing Propeller on Engine Flange.....	Figure 3-2..... 3-12
Mounting Bolt and Washer	Figure 3-3..... 3-13
Determining Torque Value When Using Torquing Adaptor	Figure 3-4 3-14
Diagram of Torquing Sequence for Propeller Mounting Bolts.....	Figure 3-5..... 3-15
Tool for Decompressing HC-(D,E)(4,5)()-3() Series External Beta System.....	Figure 3-6 3-20
Carbon Block and Beta Ring Clearance.....	Figure 3-7 3-22
Carbon Block Assembly.....	Figure 3-8..... 3-22
Hub-to-Spacer O-ring Location in the Spacer .	Figure 3-9..... 3-26
Installing the HC-E4W-3() Propeller on Engine Flange	Figure 3-10..... 3-28
Installing the Washer on the Mounting Stud..	Figure 3-11 3-30
Installing the HC-E4W-5L Propeller on Engine Flange	Figure 3-12..... 3-32
Beta Valve System	Figure 3-13..... 3-40
Beta Valve System in the Propeller	Figure 3-14..... 3-41
Front View of the Beta Valve System in the Propeller	Figure 3-15..... 3-42
Rear View of the Beta Valve System in the Propeller	Figure 3-16..... 3-43

LIST OF FIGURES, CONTINUED

	<u>Page</u>
Filed Rod for Set Screw.....	Figure 3-17 3-47
Spinner Assembly for HC-(D,E)4()-(2,3,5)() and HC-E5N-3() with D-5505-1() Spinner Assembly.....	Figure 3-18 3-50
Spinner Reassembly Procedures.....	Figure 3-19 3-51
Optional Tape on the Spinner Forward Bulkhead	Figure 3-19.1 3-52
D-5527-1() Spinner Assembly	Figure 3-20 3-54
Checking Blade Track.....	Figure 5-1 5-24
Blade Play	Figure 5-2 5-24
Turbine Engine Overspeed Limits	Figure 5-3 5-30
Turbine Engine Overtorque Limits.....	Figure 5-4 5-31
Example of an Evaluation of Ground Idle RPM Check	Figure 5-5 5-34
Corrective Action Required.....	Figure 5-6 5-35
Lubrication Fitting	Figure 6-1 6-4
Repair Limitations.....	Figure 6-2 6-11

LIST OF TABLES

	<u>Pages</u>
Propeller/Engine Flange O-rings and Mounting Hardware	Table 3-1 3-9
Torque Table.....	Table 3-2 3-16
Approved Touch-Up Paints.....	Table 6-1 6-15

INTRODUCTION - CONTENTS

1. Purpose	1-3
2. Airworthiness Limits	1-3
3. Airframe or Engine Modifications	1-4
4. Restrictions and Placards.....	1-5
5. General.....	1-6
A. Personnel Requirements	1-6
B. Maintenance Practices.....	1-6
C. Continued Airworthiness	1-9
D. Propeller Critical Parts	1-9
6. Reference Publications	1-10
7. Definitions.....	1-11
8. Abbreviations.....	1-15
9. Hartzell Propeller Inc. Product Support	1-16
10. Warranty Service	1-16
11. Hartzell Recommended Facilities.....	1-17

(This page is intentionally blank.)

1. Purpose

- A. This manual has been reviewed and accepted by the FAA. Additionally, the Airworthiness Limitations chapter of this manual has been approved by the FAA.

CAUTION: KEEP THIS MANUAL WITH THE PROPELLER OR WITH THE AIRCRAFT ON WHICH IT IS INSTALLED, AT ALL TIMES. THE LOG BOOK RECORD WITHIN THIS MANUAL MUST BE MAINTAINED, RETAINED CONCURRENTLY, AND BECOME A PART OF THE AIRCRAFT AND ENGINE SERVICE RECORDS.

- B. This manual supports constant speed feathering and reversing lightweight turbine propellers with aluminum blades.

- C. The purpose of this manual is to enable qualified personnel to install, operate, and maintain a Hartzell Propeller Inc. Constant Speed Feathering or Constant Speed Feathering and Reversing Lightweight Turbine Propeller. Separate manuals are available concerning overhaul procedures and specifications for the propeller.

- D. This manual covers several design types. Sample hub and blade model numbers within this design are covered in the Description and Operation chapter of this manual.

NOTE: All propeller models covered by this manual use aluminum propeller blades. Identical propeller types that use composite blades are supported by Hartzell Propeller Inc. Manual 147 (61-00-47).

2. Airworthiness Limits

- A. Refer to the Airworthiness Limitations chapter of this manual for Airworthiness Limits information.

3. Airframe or Engine Modifications

- A. Propellers are approved vibrationwise on airframe and engine combinations based on tests or analysis of similar installations. This data has demonstrated that propeller stress levels are affected by airframe configuration, airspeed, weight, power, engine configuration and approved flight maneuvers. Aircraft modifications that can effect propeller stress include, but are not limited to: aerodynamic changes ahead of or behind the propeller, realignment of the thrust axis, increasing or decreasing airspeed limits, increasing or decreasing weight limits (less significant on piston engines), and the addition of approved flight maneuvers (utility and aerobatic).
- B. Engine modifications can Affect the propeller. The two primary categories of engine modifications are those that affect structure and those that affect power. An example of a structural engine modification is the alteration of the crankshaft or damper of a piston engine. Any change to the weight, stiffness or tuning of rotating components could result in a potentially dangerous resonant condition that is not detectable by the pilot. Most common engine modifications affect the power during some phase of operation. Some modifications increase the maximum power output, while others improve the power available during hot and high operation (flat rating) or at off-peak conditions. Examples of such engine modifications include, but are not limited to: changes to the compressor, power turbine or hot section of a turboprop engine; and on piston engines, the addition or alteration of a turbocharger or turbonormalizer, increased compression ratio, increased rpm, altered ignition timing, electronic ignition, full authority digital electronic controls (FADEC), or tuned induction or exhaust.
- C. All such modifications must be reviewed and approved by the propeller manufacturer before obtaining approval on the aircraft.

4. Restrictions and Placards

- A. The propellers covered by this manual may have a restricted operating range that requires a cockpit placard. The restrictions, if present, will vary depending on the propeller, blade, engine, and/or aircraft model. Review the propeller and aircraft type certificate data sheet (TCDS), Pilot Operating Handbook (POH), and any applicable Airworthiness Directives for specific information.

WARNING: STABILIZED GROUND OPERATION WITHIN THE PROPELLER RESTRICTED RPM RANGE CAN GENERATE HIGH PROPELLER STRESSES AND RESULT IN FATIGUE DAMAGE TO THE PROPELLER. THIS DAMAGE CAN LEAD TO A REDUCED PROPELLER FATIGUE LIFE, PROPELLER FAILURE, AND LOSS OF CONTROL OF THE AIRCRAFT. THE PROPELLER RESTRICTED RPM RANGE IS DEFINED IN THE AIRPLANE FLIGHT MANUAL.

- B. The propeller operating restrictions or limitations are found in the Airplane Flight Manual (AFM) or Airplane Flight Manual Supplement (AFMS).
- C. If a propeller RPM operating restriction or limitation is violated, refer to the Special Inspections section in the Inspection and Check chapter of this manual for corrective actions.

5. General**A. Personnel Requirements****(1) Inspection, Repair, and Overhaul**

- (a) Compliance to the applicable regulatory requirements established by the Federal Aviation Administration (FAA) or foreign equivalent is mandatory for anyone performing or accepting responsibility for any inspection and/or repair and/or overhaul of any Hartzell Propeller Inc. product.
- (b) Personnel performing maintenance on aluminum hub propellers are expected to have sufficient training and certifications (when required by the applicable Aviation Authority) to accomplish the work required in a safe and airworthy manner.

B. Maintenance Practices

- (1) The propeller and its components are highly vulnerable to damage while they are removed from the engine. Properly protect all components until they are reinstalled on the engine.
- (2) Never attempt to move the aircraft by pulling on the propeller.
- (3) Avoid the use of blade paddles. If blade paddles must be used, use at least two paddles. Do not place the blade paddle in the area of the de-ice boot when applying torque to a blade assembly. Place the blade paddle in the thickest area of the blade, just outside of the de-ice boot. Use one blade paddle per blade.
- (4) Use only the approved consumables, e.g., cleaning agents, lubricants, etc.
- (5) Safe Handling of Paints and Chemicals
 - (a) Always use caution when handling or being exposed to paints and/or chemicals during propeller overhaul and maintenance procedures.
 - (b) Before using paint or chemicals, always read the manufacturer's label on the container and follow specified instructions and procedures for storage, preparation, mixing, and application.

- (c) Refer to the product's Material Safety Data Sheet (MSDS) for detailed information about physical properties, health, and physical hazards of any chemical.
- (6) Observe applicable torque values during maintenance.
- (7) Approved corrosion protection followed by approved paint must be applied to all aluminum blades. For information concerning the application of corrosion protection and paint, refer to the Maintenance Practices chapter of this manual. Operation of blades without the specified coatings and finishes, i.e., "polished blades", is not permitted.
- (8) Before installing the propeller on the engine, the propeller must be static balanced. New propellers are statically balanced at Hartzell Propeller Inc. Overhauled propellers must be statically balanced by a certified propeller repair station with the appropriate rating before return to service.

NOTE: Dynamic balance is recommended, but may be accomplished at the discretion of the operator, unless specifically required by the airframe or engine manufacturer. Dynamic balancing is to be accomplished in accordance with the procedures and limitations in Maintenance Practices chapter of this manual. Additional procedures may be found in the aircraft maintenance manual.

- (9) As necessary, use a soft, non-graphite pencil or crayon to make identifying marks on components.
- (10) As applicable, follow military standard NASM33540 for safety wire and cotter pin general practices. Use 0.032 inch (0.81 mm) diameter stainless steel safety wire unless otherwise indicated.

WARNING: DO NOT USE OBSOLETE OR OUTDATED INFORMATION. PERFORM ALL INSPECTIONS OR WORK IN ACCORDANCE WITH THE MOST RECENT REVISION OF THIS MANUAL. INFORMATION CONTAINED IN THIS MANUAL MAY BE SIGNIFICANTLY CHANGED FROM EARLIER REVISIONS. FAILURE TO COMPLY WITH THIS MANUAL OR THE USE OF OBSOLETE INFORMATION MAY CREATE AN UNSAFE CONDITION THAT MAY RESULT IN DEATH, SERIOUS BODILY INJURY, AND/OR SUBSTANTIAL PROPERTY DAMAGE. FOR THE MOST RECENT REVISION LEVEL OF THIS MANUAL, REFER TO THE HARTZELL PROPELLER INC. WEBSITE AT WWW.HARTZELLPROP.COM.

- (11) The information in this manual supersedes data in all previously published revisions of this manual.
- (12) Refer to the airframe manufacturer's manuals in addition to the information in this manual because of possible special requirements for specific aircraft applications.
- (13) If the propeller is equipped with an ice protection system that uses components supplied by Hartzell Propeller Inc., applicable instructions and technical information for the components supplied by Hartzell Propeller Inc. can be found in the following publications available on the Hartzell Propeller Inc. website at www.hartzellprop.com:
 - (a) Hartzell Propeller Inc. Manual 180 (30-61-80) - Propeller Ice Protection System Manual
 - (b) Hartzell Propeller Inc. Manual 181 (30-60-81) - Propeller Ice Protection Component Maintenance Manual
 - (c) Hartzell Propeller Inc. Manual 182 (61-12-82) - Propeller Electrical De-ice Boot Removal and Installation Manual

(d) Hartzell Propeller Inc. Manual 183 (61-12-83) - Propeller Anti-icing Boot Removal and Installation Manual

(14) Propeller ice protection system components not supplied by Hartzell Propeller Inc. are controlled by the applicable TC or STC holder's Instructions for Continued Airworthiness (ICA).

(15) Approved corrosion protection followed by approved paint must be applied to all aluminum blades. For information concerning the application of corrosion protection and paint, refer to the Maintenance Practices chapter of this manual. Operation of blades without the specified coatings and finishes, i.e., "polished blades", is not permitted.

C. Continued Airworthiness

(1) Operators are urged to stay informed of airworthiness information via Hartzell Propeller Inc. Service Bulletins and Service Letters, that are available from Hartzell Propeller Inc. distributors or from the Hartzell Propeller Inc. factory by subscription. Selected information is Available on the Hartzell Propeller Inc. website at www.hartzellprop.com.

D. Propeller Critical Parts

(1) The following maintenance procedures may involve propeller critical parts. These procedures have been substantiated based on Engineering analysis that expects this product will be operated and maintained using the procedures and inspections provided in the Instructions for Continued Airworthiness (ICA) for this product. Refer to the Illustrated Parts List chapter of the applicable maintenance manual for the applicable propeller model for the identification of specific propeller Critical Parts.

(2) Numerous propeller system parts can produce a propeller Major or Hazardous effect, even though those parts may not be considered as Critical Parts. The operating and maintenance procedures and inspections provided in the ICA for this product are, therefore, expected to be accomplished for all propeller system parts.

6. Reference Publications

The following publications are referenced within this manual:

Active Hartzell Propeller Inc. Service Bulletins, Service Letters, Service Instructions, and Service Advisories

Hartzell Propeller Inc. Manual No. 127 (61-16-27) - Metal Spinner Assembly Maintenance

Hartzell Propeller Inc. Manual No. 133C (61-13-33) - Aluminum Propeller Blade Maintenance Manual

Hartzell Propeller Inc. Manual No. 141 (61-10-41) - Four-Blade Lightweight Turbine Propeller Maintenance Manual

Hartzell Propeller Inc. Manual No. 142 (61-10-42) - Three and Four-Blade Lightweight Turbine Propeller Maintenance Manual

Hartzell Propeller Inc. Manual No. 143A (61-10-43) - Four-Blade Lightweight Turbine Propeller Maintenance Manual

Hartzell Propeller Inc. Manual No. 159 (61-02-59) - Application Guide - Available on the Hartzell Propeller Inc. website at www.hartzellprop.com

Hartzell Propeller Inc. Manual No. 158A (61-10-58) - Five and Six-Blade Lightweight Turbine Propeller Maintenance Manual

Hartzell Propeller Inc. Manual No. 165A (61-00-65) - Illustrated Tool and Equipment

Hartzell Propeller Inc. Manual No. 180 (30-61-80) - Propeller Ice Protection System Manual - Available on the Hartzell Propeller Inc. website at www.hartzellprop.com

Hartzell Propeller Inc. Manual No. 181 (30-60-81) - Propeller Ice Protection Component Maintenance Manual - Available on the Hartzell Propeller Inc. website at www.hartzellprop.com

Hartzell Propeller Inc. Manual No. 182 (61-12-82) - Propeller Electrical De-ice Boot Removal and Installation Manual - Available on the Hartzell Propeller Inc. website at www.hartzellprop.com

Hartzell Propeller Inc. Manual No. 183 (61-12-83) - Propeller Anti-icing Boot Removal and Installation Manual - Available on the Hartzell Propeller Inc. website at www.hartzellprop.com

Hartzell Propeller Inc. Manual No. 202A (61-01-02) - Standard Practices Manual - Volumes 1 through 11 (Volume 7, Consumable Materials is available on the Hartzell Propeller Inc. website at www.hartzellprop.com)

Hartzell Propeller Inc. Service Letter HC-SL-61-61Y - Overhaul Periods and Service Life Limits for Hartzell Propeller Inc. Aviation Components - Propellers, Governors, and Propeller Damper Assemblies - Available on the Hartzell Propeller Inc. website at www.hartzellprop.com

7. Definitions

A basic understanding of the following terms will assist in maintaining and operating Hartzell Propeller Inc. propeller systems.

<u>Term</u>	<u>Definition</u>
Annealed	Softening of material due to overexposure to heat.
Blade Angle	Measurement of blade airfoil location described as the angle between the blade airfoil and the surface described by propeller rotation.
<u>Term</u>	<u>Definition</u>
Brinelling	A depression caused by failure of the material in compression.
Chord	A straight line between the leading and trailing edges of an airfoil.
Cold Rolling	Compressive rolling process for the retention area of single shoulder blades which provides improved strength and resistance to fatigue.
Constant Force.	A force which is always present in some degree when the propeller is operating.
Constant Speed	A propeller system which employs a governing device to maintain a selected engine RPM.

<u>Term</u>	<u>Definition</u>
Corrosion	Gradual material removal or deterioration due to chemical action.
Crack	Irregularly shaped separation within a material, sometimes visible as a narrow opening at the surface.
Depression	Surface area where the material has been compressed but not removed.
Distortion	Alteration of the original shape or size of a component.
Erosion	Gradual wearing away or deterioration due to action of the elements.
Exposure	Material open to action of the elements.
Feathering	A propeller with blades that may be positioned parallel to the relative wind, thus reducing aerodynamic drag.
Gouge	Surface area where material has been removed.
Hazardous Propeller	
Effect	The hazardous propeller effects are defined in Title 14 CFR section 35.15(g)(1).
Horizontal Balance	Balance between the blade tip and the center of the hub.
Impact Damage	Damage that occurs when the propeller blade or hub assembly strikes, or is struck by, an object while in flight or on the ground.
Major Propeller Effect	The major propeller effects are defined in Title 14 CFR section 35.15(g)(2).
Nick	Removal of paint and possibly a small amount of material.

<u>Term</u>	<u>Definition</u>
Onspeed	Condition in which the RPM selected by the pilot through the propeller control lever and the actual engine (propeller) RPM are equal.
Overhaul	The periodic disassembly, inspection, repair, refinish, and reassembly of a propeller assembly to maintain airworthiness.
Overspeed	Condition in which the RPM of the propeller or engine exceeds predetermined maximum limits; the condition in which the engine (propeller) RPM is higher than the RPM selected by the pilot through the propeller control lever.
Overspeed Damage	Damage that occurs when the propeller hub assembly rotates at a speed greater than the maximum limit for which it is designed.
Pitch	Same as "Blade Angle".
Pitting	Formation of a number of small, irregularly shaped cavities in surface material caused by corrosion or wear
Propeller Critical Part	A part on the propeller whose primary failure can result in a hazardous propeller effect, as determined by the safety analysis required by Title 14 CFR section 35.15
Reversing	The capability of rotating blades to a position to generate reverse thrust to slow the aircraft or back up.
Scratch	Same as "Nick".
Single Acting	Hydraulically actuated propeller which utilizes a single oil supply for pitch control.

<u>Term</u>	<u>Definition</u>
Superseded	Parts that are considered airworthy for continued flight but may no longer be available.
Synchronizing	Adjusting the RPM of all the propellers of a multi-engine aircraft to the same RPM.
Synchrophasing	A form of propeller sychronization in which not only the RPM of the engines (propellers) are held constant, but also the position of the propellers in relation to each other.
Track	In an assembled propeller, a measurement of the location of the blade tip with respect to the plane of rotation, used to verify face alignment and to compare blade tip location with respect to the locations of the other blades in the
Underspeed	The condition in which the actual engine (propeller) RPM is lower than the RPM selected by the pilot through the propeller control lever.
Variable Force	A force which may be applied or removed during propeller operation.
Windmilling	The rotation of an aircraft propeller caused by air flowing through it while the engine is not producing power.

8. Abbreviations

<u>Abbreviation</u>	<u>Term</u>
AMM	Aircraft Maintenance Manual
AN	Air Force-Navy (or Army-Navy)
AOG	Aircraft on Ground
FAA	Federal Aviation Administration
Ft-Lb	Foot-Pound
ICA	Instructions for Continued Airworthiness
ID	Inside Diameter
In-Lb	Inch-Pound
IPS	Inches Per Second
Lbs	Pounds
MIL-X-XXX	Military Specification
MPI	Major Periodic Inspection
MS	Military Standard
MSDS	Material Safety Data Sheet
NAS	National Aerospace Standards
NASM	National Aerospace Standards, Military
NIST	National Institute of Standards and Technology
N•m	Newton-Meters
OD	Outside Diameter
POH	Pilot's Operating Handbook
PSI	Pounds per Square Inch
RPM	Revolutions per Minute
TBO	Time Between Overhaul
TSN	Time Since New
TSO	Time Since Overhaul
<u>NOTE:</u>	TSN/TSO is considered as the time accumulated between rotation and landing, i.e., flight time.

9. Hartzell Propeller Inc. Product Support

Hartzell Propeller Inc. is ready to assist you with questions concerning your propeller system. Hartzell Propeller Inc. Product Support may be reached during business hours (8:00 a.m. through 5:00 p.m., United States Eastern Time) at (937) 778-4379 or at (800) 942-7767, toll free from the United States and Canada. Hartzell Propeller Inc. Product Support can also be reached by fax at (937) 778-4391, and by e-mail at techsupport@hartzellprop.com. After business hours, you may leave a message on our 24 hour product support line at (937) 778-4376 or at (800) 942-7767, toll free from the United States and Canada. A technical representative will contact you during normal business hours. Urgent AOG support is Available 24 hours per day, seven days per week via this message service. Additional information is available on our website at www.hartzellprop.com.

NOTE: When calling from outside the United States, dial (001) before dialing the above telephone numbers.

10. Warranty Service

If you believe you have a warranty claim, it is necessary to contact Hartzell Propeller Inc.'s Warranty Administrator. Hartzell Propeller Inc.'s Warranty Administrator will provide a blank *Warranty Application* form. It is necessary to complete this form and return it to the Warranty Administrator for evaluation **before proceeding with repair or inspection work**. Upon receipt of this form, the Warranty Administrator will provide instructions on how to proceed. Hartzell Propeller Inc. Warranty may be reached during business hours (8:00 a.m. through 5:00 p.m., United States Eastern Time) at (937) 778-4380, or toll free from the United States and Canada at (800) 942-7767. Hartzell Propeller Inc. Warranty Administration can also be reached by fax, at (937) 778-4391, or by e-mail at warranty@hartzellprop.com.

NOTE: When calling from outside the United States, dial (001) before dialing the above telephone numbers.

11. Hartzell Propeller Inc. Recommended Facilities

- A. Hartzell Propeller Inc. recommends using Hartzell Propeller Inc. approved distributors and repair facilities for the purchase, repair and overhaul of Hartzell Propeller Inc. propeller assemblies or components.
- B. Information about the Hartzell Propeller Inc. worldwide network of aftermarket distributors and approved repair facilities is available on the Hartzell Propeller Inc. website at www.hartzellprop.com.

(This page is intentionally blank.)

DESCRIPTION AND OPERATION - CONTENTS

1. Functional Description of Constant Speed Propeller Types ...	2-5
A. Feathering Propellers HC-(D,E)4()-2() Series.....	2-5
B. Feathering and Reversing Propellers HC-(D,E)4,5()-3() Series	2-11
C. Feathering and Reversing Propellers HC-(D,E)4()-5() Series	2-15
D. Feathering and Reversing Propellers HC-D3F-7() Series	2-20
2. Model Designation.....	2-22
A. Aluminum Hub Propeller Model Identification	2-22
B. Aluminum Blade Model Identification	2-24
3. Governors.....	2-27
A. Theory of Operation	2-27
4. Propeller Ice Protection Systems	2-28
A. Propeller Anti-ice System.....	2-28
B. Propeller De-ice System	2-29



LIST OF FIGURES

HC-(D,E)4A-2() Series Propeller	Figure 2-1	2-3
HC-(D,E)4N-2() Series Propeller	Figure 2-2	2-4
HC-(D,E)4N-3() Series Propeller with Start Locks	Figure 2-3	2-7
HC-(D,E)4N-3() Series Propeller	Figure 2-4	2-8
HC-(D,E)4A-3() Series Propeller	Figure 2-5	2-9
HC-E4P-3K Series Propeller	Figure 2-5.1	2-10
HC-E4W-3() Series Propeller	Figure 2-5.2	2-10.1
HC-(D,E)5()-3() Series Propeller	Figure 2-6	2-10.2
HC-(D,E)4()-5() Series Propeller	Figure 2-7	2-14
HC-E4W-5() Series Propeller	Figure 2-7.1	2-14.1
HC-D3F-7 Series Propeller	Figure 2-8	2-18
HC-D3F-7H Series Propeller	Figure 2-9	2-19
Governor in Onspeed Condition	Figure 2-10	2-26
Governor in Underspeed Condition	Figure 2-11	2-26
Governor in Overspeed Condition	Figure 2-12	2-26

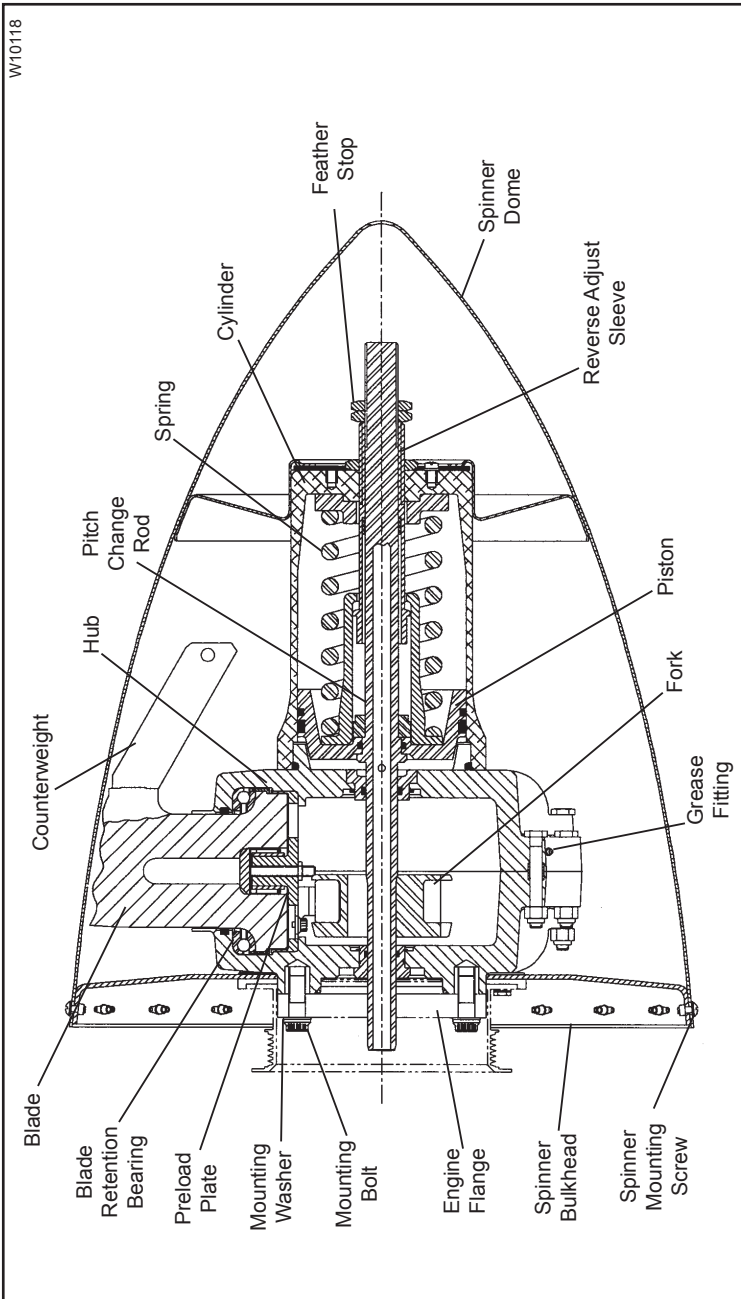

HC-(D,E)4A-2() Series Propeller
Figure 2-1

W10119

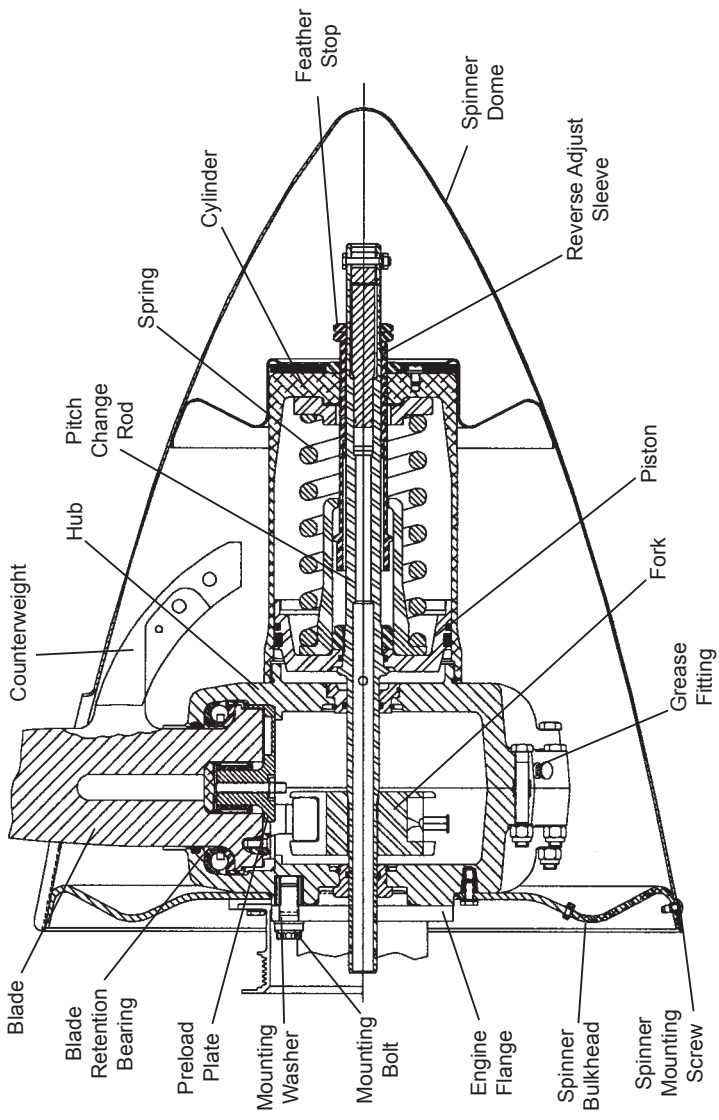

HC-(D,E)4N-2() Series Propeller
Figure 2-2

1. Functional Description of Constant Speed Propeller Types**A. Feathering Propellers HC-(D,E)4()-2() Series**

Refer to Figures 2-1 and 2-2. The propellers described in this section are constant speed and feathering. They use a single oil supply from a governing device to hydraulically actuate a change in blade angle. The propellers have four blades and are used primarily on Pratt & Whitney turbine engines.

A two piece aluminum hub retains each propeller blade on a thrust bearing. A cylinder is threaded onto the hub and contains a feathering spring and piston. The hydraulically actuated piston transmits linear motion through a pitch change rod and fork to each blade to result in blade angle change.

While the propeller is operating, the following forces are constantly present: 1) spring force, 2) counterweight force, 3) centrifugal twisting moment of each blade and 4) blade aerodynamic twisting forces. The spring and counterweight forces attempt to rotate the blades to higher blade angle while the centrifugal twisting moment of each blade is generally toward lower blade angle. Blade aerodynamic twisting force is generally very small in relation to the other forces and can attempt to increase or decrease blade angle.

The summation of the propeller forces is toward higher pitch (low RPM) and is opposed by a variable force toward lower pitch (high RPM). The variable force is oil under pressure from a governor with an internal pump that is mounted on and driven by the engine. The oil from the governor is supplied to the propeller and hydraulic piston through a hollow engine shaft. Increasing the volume of oil within the piston and cylinder will decrease the blade angle and increase propeller RPM. Decreasing the volume of oil will increase blade angle and decrease propeller RPM. By changing the blade angle, the governor can vary the load on the engine and maintain constant engine RPM (within limits), independent of where the power lever is set. The governor uses engine speed sensing mechanisms that allow it to supply or drain oil as necessary to maintain constant engine speed (RPM).

If governor supplied oil is lost during operation, the propeller will increase pitch and feather. Feathering occurs because the summation of internal propeller forces causes the oil to drain out of the propeller until the feather stop position is reached.

Normal in-flight feathering is accomplished when the pilot retards the propeller condition lever past the feather detent. This allows control oil to drain from the propeller and return to the engine sump. Engine shutdown is normally accomplished during the feathering process.

Normal in-flight unfeathering is accomplished when the pilot positions the propeller condition lever into the normal flight (governing) range and restarts the engine. As engine speed increases, the governor supplies oil to the propeller and the blade angle decreases.

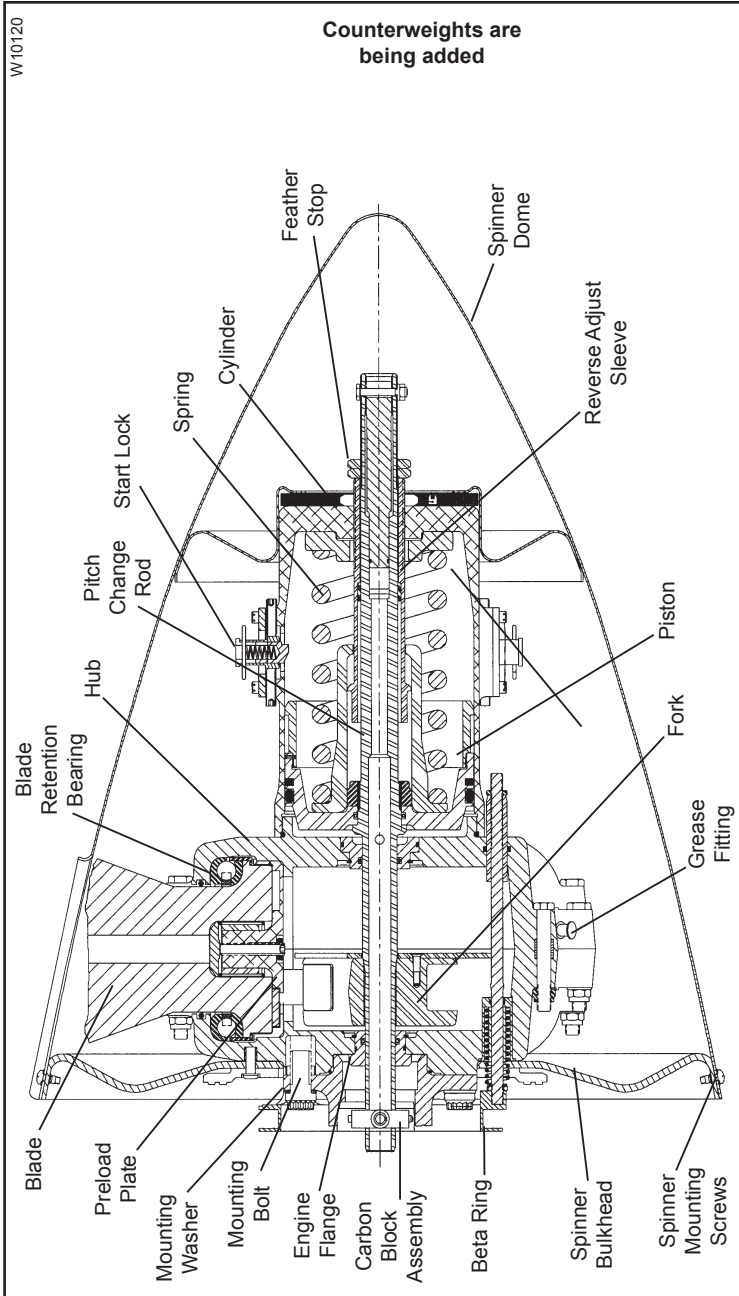

HC-(D,E)4N-3() Series Propeller with Start Locks
Figure 2-3

W10121

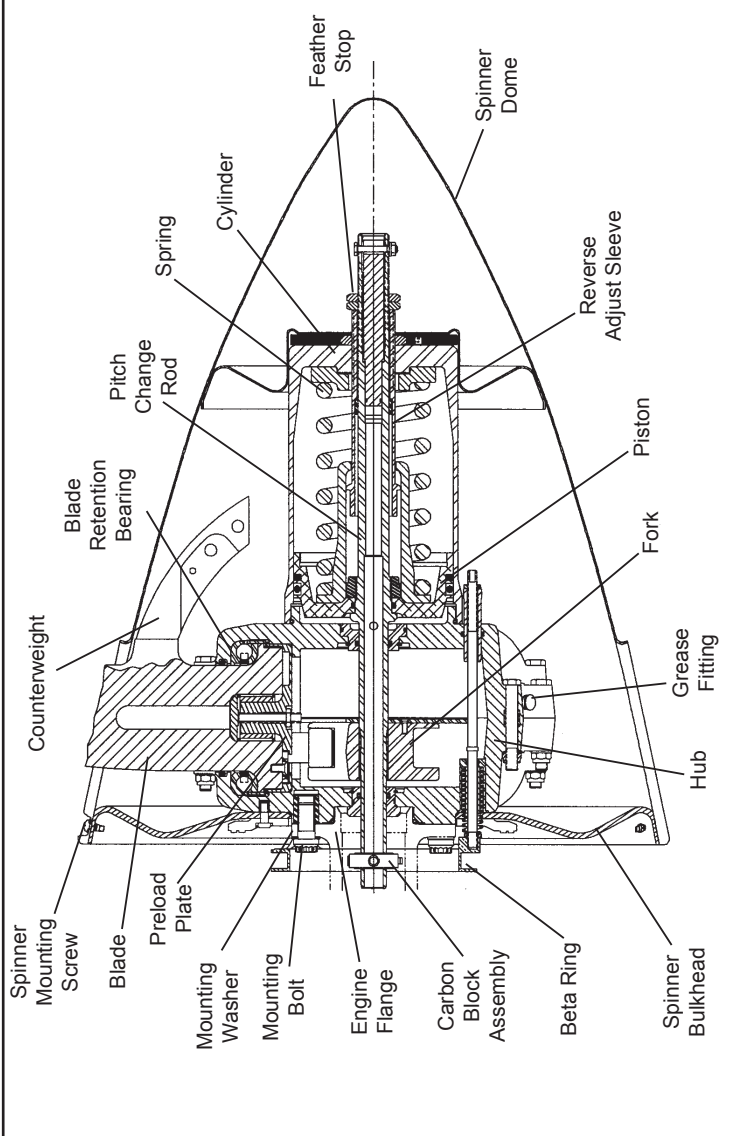

HC-(D,E)4N-3() Series Propeller
Figure 2-4

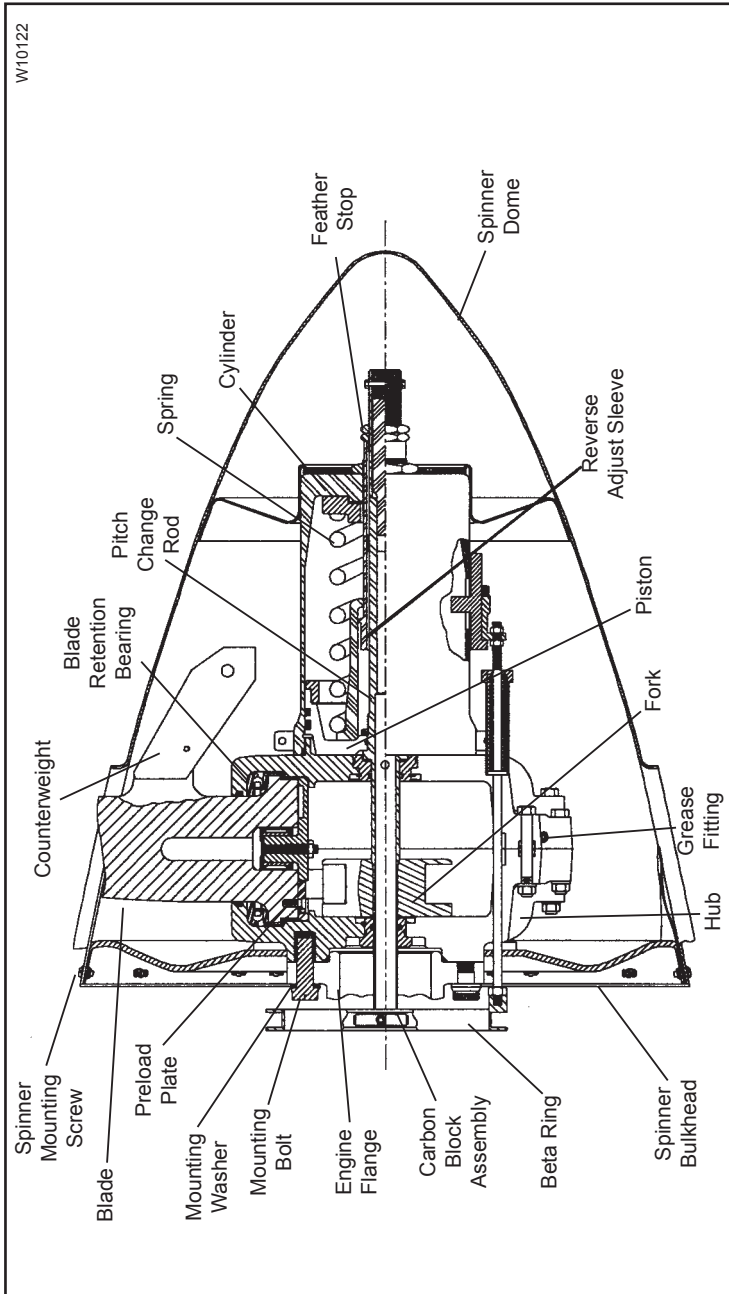

HC-(D,E)4A-3() Series Propeller
Figure 2-5

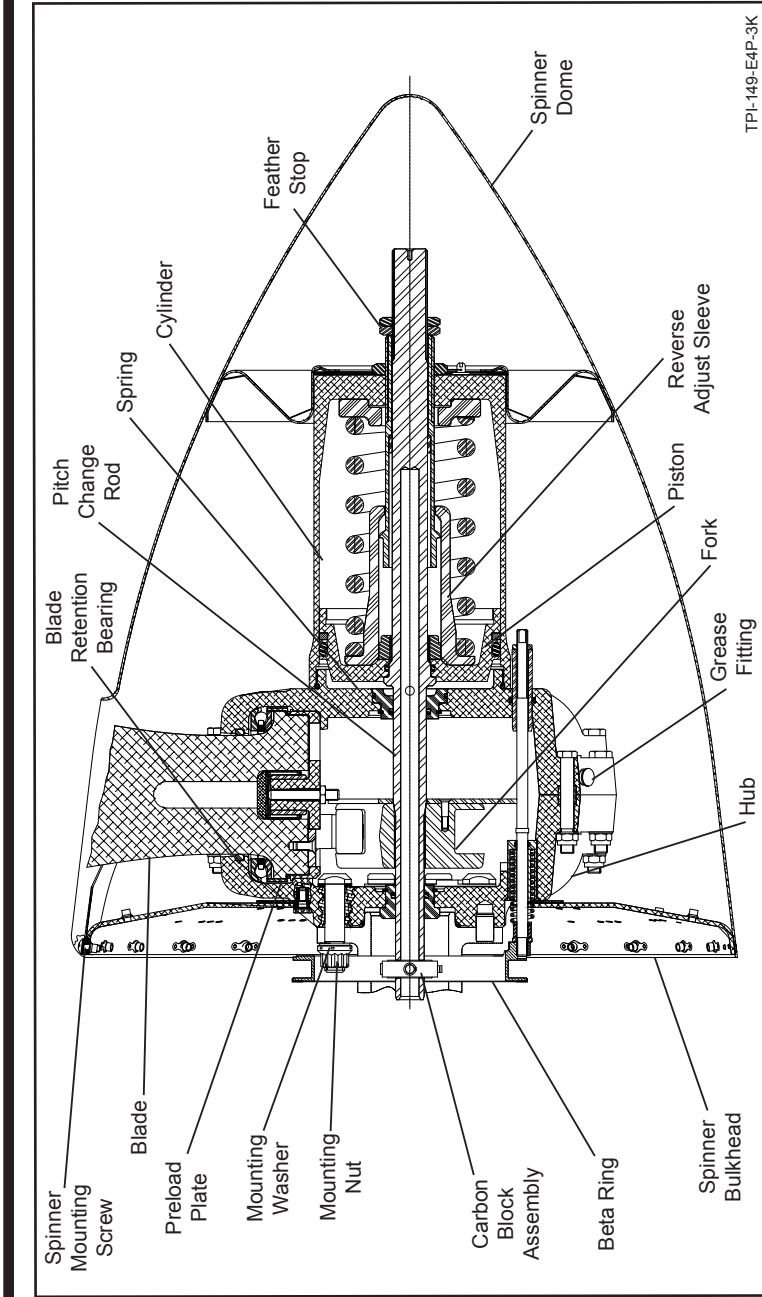

HC-E4P-3K Series Propeller
Figure 2-5.1

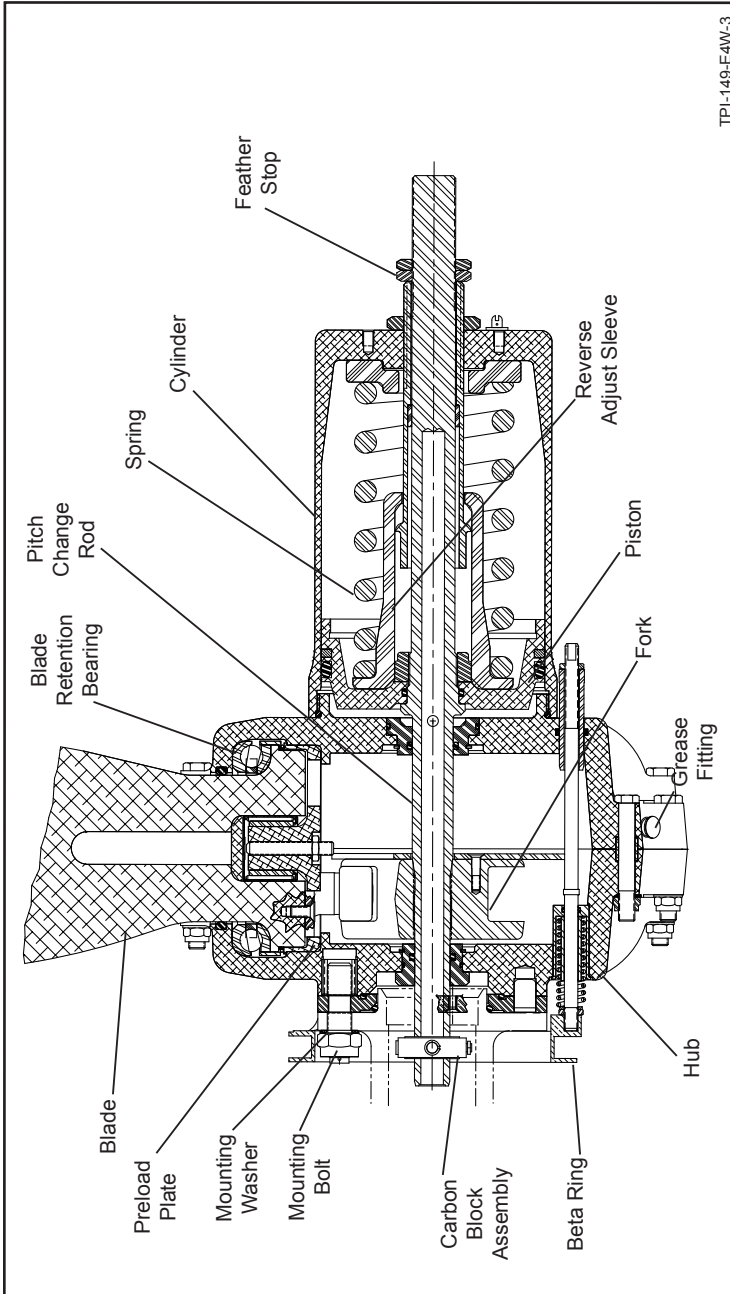

HC-E4W-3 () Series Propeller
Figure 2-5.2

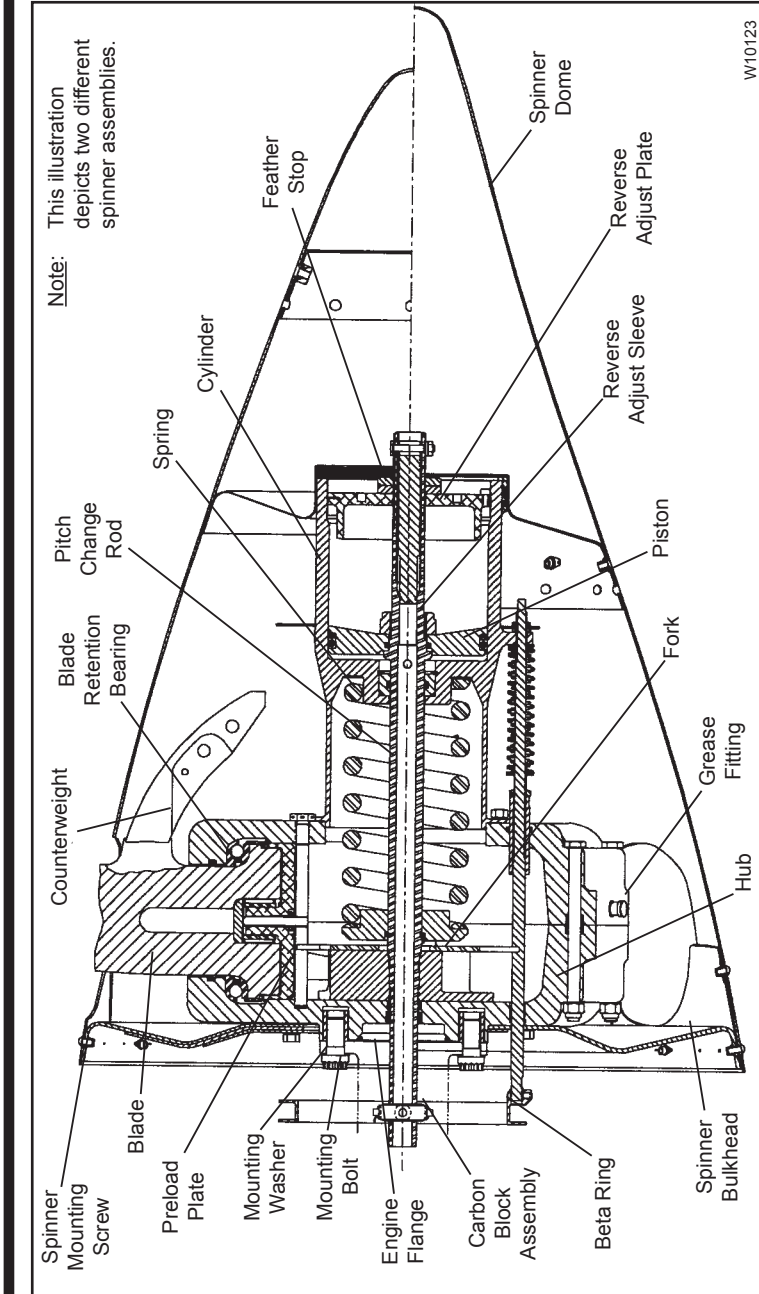

HC-(D,E)5(-)3() Series Propeller
Figure 2-6

B. Feathering and Reversing Propellers
HC-(D,E)(4,5)()-3() Series

Refer to Figures 2-3 through 2-6. The propellers described in this section are constant speed, feathering and reversing. They use a single oil supply from a governing device to hydraulically actuate a change in blade angle. The propellers may have four or five blades and are used primarily on Pratt & Whitney turbine engines.

A two piece aluminum hub retains each propeller blade on a thrust bearing. A cylinder is attached to the hub and contains a feathering spring and piston. The hydraulically actuated piston transmits linear motion through a pitch change rod and fork to each blade to result in blade angle change.

While the propeller is operating the following forces are constantly present, 1) spring force, 2) counterweight force, 3) centrifugal twisting moment of each blade and 4) blade aerodynamic twisting forces. The spring and counterweight forces attempt to rotate the blades to higher blade angle while the centrifugal twisting moment of each blade is generally toward lower blade angle. Blade aerodynamic twisting force is generally very small in relation to the other forces and can attempt to increase or decrease blade angle.

Summation of the propeller forces is toward higher pitch (low RPM) and is opposed by a variable force toward lower pitch (high RPM). The variable force is oil under pressure from a governor with an internal pump that is mounted on and driven by the engine. The oil from the governor is supplied to the propeller and hydraulic piston through a hollow engine shaft. Increasing the volume of oil within the piston and cylinder will decrease the blade angle and increase propeller RPM. Decreasing the volume of oil will increase blade angle and decrease propeller RPM. By changing the blade angle, the governor can vary the load on the engine and maintain constant engine RPM (within limits), independent of where the power lever is set. The governor uses engine speed sensing mechanisms that allow it to supply or drain oil as necessary to maintain constant engine speed (RPM).

If governor supplied oil is lost during operation, the propeller will increase pitch and feather. Feathering occurs because the summation of internal propeller forces causes the oil to drain out of the propeller until the feather stop position is reached.

Normal in-flight feathering is accomplished when the pilot retards the propeller condition lever past the feather detent. This allows control oil to drain from the propeller and return to the engine sump. Engine shutdown is normally accomplished during the feathering process.

Normal in-flight unfeathering is accomplished when the pilot positions the propeller condition lever into the normal flight (governing) range and restarts the engine. As engine speed increases, the governor supplies oil to the propeller and the blade angle decreases.

In reverse mode of operation, the governor operates in an underspeed condition to act strictly as a source of pressurized oil, without attempting to control RPM. Control of the propeller blade angle in reverse is accomplished with the beta valve.

NOTE: The beta valve is normally built into the base of the governor.

The propeller is reversed by manually repositioning the cockpit-control to cause the beta valve to supply oil from the governor pump to the propeller. Several external propeller mechanisms, which include a beta ring and carbon block assembly, communicate propeller blade angle position to the beta valve.

When the propeller reaches the desired reverse position, movement of the beta ring and carbon block assembly initiated by the propeller piston, causes the beta valve to shut off the flow of oil to the propeller. Any additional unwanted movement of the propeller toward reverse, or any movement of the manually positioned beta valve control toward high pitch position will cause the beta valve to drain oil from the propeller to increase pitch.

(This page is intentionally blank.)

W10124A

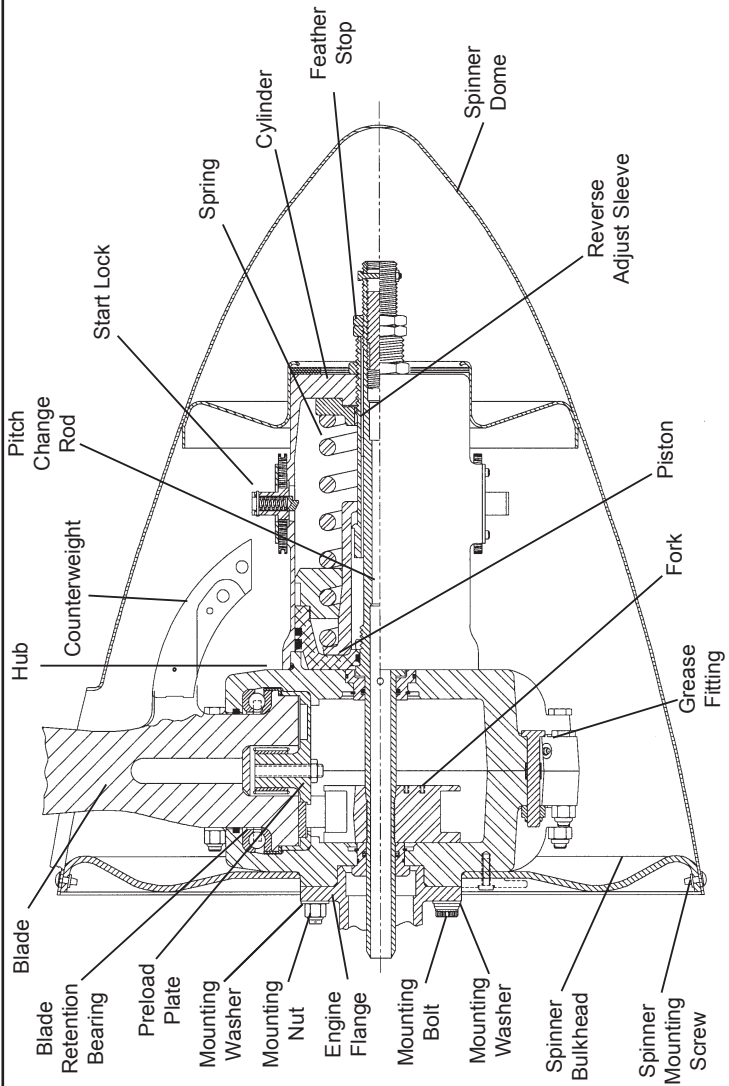

**HC-(D,E)4(-)5() Series Propeller
Figure 2-7**

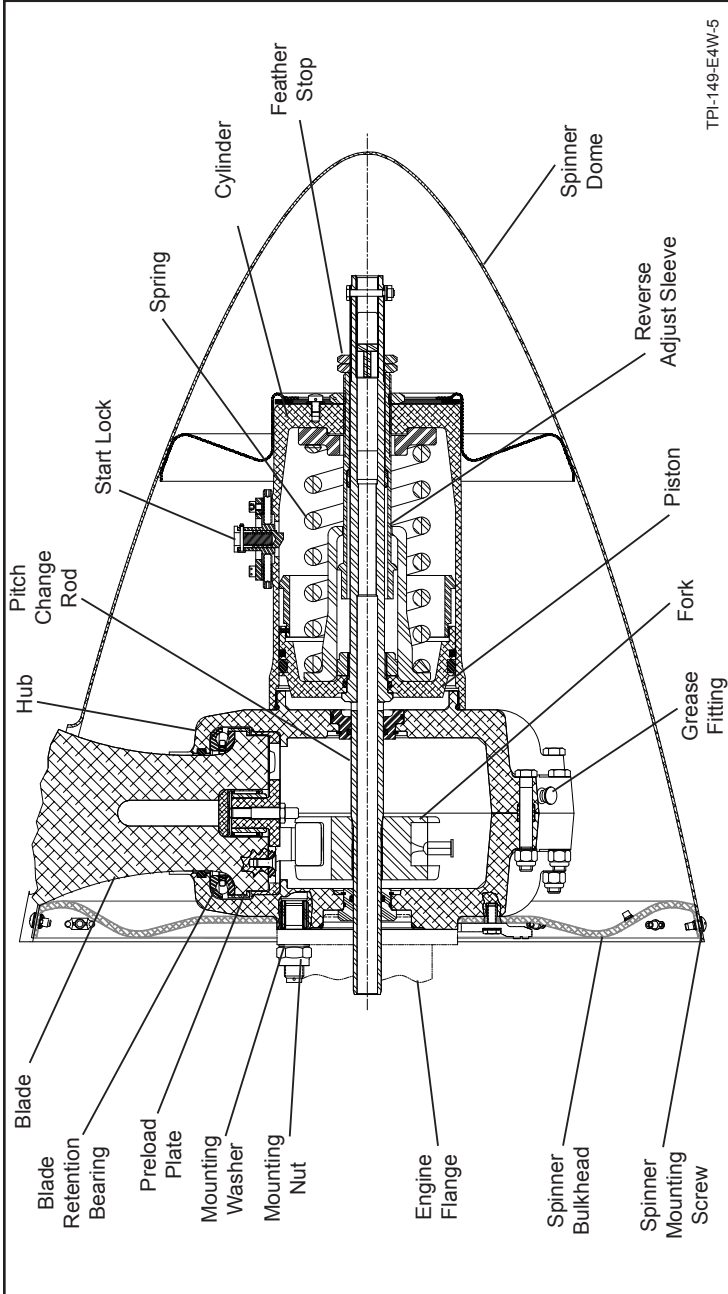

TPI-149-E4W-5

**HC-E4W-5() Series Propeller
Figure 2-7.1**

(This page is intentionally blank.)

C. Feathering and Reversing Propellers
HC-(D,E)4()-5() Series

Refer to Figure 2-7. The propellers described in this section are constant speed, feathering and reversing. They use a single oil supply from a governing device to hydraulically actuate a change in blade angle. These propellers have four blades and are used primarily on Garrett (Allied Signal) turbine engines.

A two piece aluminum hub retains each propeller blade on a thrust bearing. A cylinder is attached to the hub and contains a feathering spring and piston. The hydraulically actuated piston transmits linear motion through a pitch change rod and fork to each blade to result in blade angle change.

While the propeller is operating, the following forces are constantly present: 1) spring force, 2) counterweight force, 3) centrifugal twisting moment of each blade and 4) blade aerodynamic twisting forces. The spring and counterweight forces attempt to rotate the blades to higher blade angle, while the centrifugal twisting moment of each blade is generally toward lower blade angle. Blade aerodynamic twisting force is usually very small in relation to the other forces and can attempt to increase or decrease blade angle.

The summation of the propeller forces is toward higher pitch (low RPM) and is opposed by a variable force toward lower pitch (high RPM). The variable force is oil under pressure from a governor with an internal pump, which is mounted on and driven by the engine. The oil from the governor is supplied to the propeller and hydraulic piston through a hollow engine shaft. Increasing the volume of oil within the piston and cylinder will decrease the blade angle and increase propeller RPM. Decreasing the volume of oil will increase blade angle and decrease propeller RPM. By changing blade angle the governor can vary the load on the engine and maintain constant engine RPM (within limits), independent of where the power lever is set. The governor uses engine speed sensing mechanisms that allow it to supply or drain oil as necessary to maintain constant engine speed (RPM).

If governor supplied oil is lost during operation, the propeller will increase pitch and feather. Feathering occurs because the summation of internal propeller forces causes the oil to drain out of the propeller until the feather stop position is reached.

Normal in-flight feathering is accomplished when the pilot retards the propeller condition lever past the feather detent. This allows control oil to drain from the propeller and return to the engine sump. Engine shutdown is normally accomplished during the feathering process.

Normal in-flight unfeathering is accomplished when the pilot positions the propeller condition lever into the normal flight (governing) range, activates the auxiliary pump to decrease blade pitch and restarts the engine. As engine speed increases, the governor supplies oil to the propeller and the blade angle decreases.

In reverse mode of operation the governor is operates in an underspeed condition to act strictly as a source of pressurized oil, without attempting to control RPM. Control of the propeller blade angle then becomes the responsibility of the beta valve.

NOTE: The beta valve is normally located on the gearbox side opposite the propeller.

The propeller is reversed by manually repositioning the cockpit-control to cause the beta valve to supply oil from the governor pump to the propeller. A beta rod inserted into the front of the propeller communicates propeller blade angle position to the beta valve.

When the propeller reaches the desired reverse position, movement of the beta rod, initiated by the propeller piston, will cause the beta valve to shut off flow of oil to the propeller. Any additional unwanted movement of the propeller toward reverse or any movement of the manually positioned beta valve control toward high pitch position will cause the beta valve to drain oil from the propeller to increase pitch.

It is undesirable to feather the propeller when the engine is stopped after landing the aircraft. This propeller type is normally installed on a fixed shaft engine that causes the propeller to rotate during an engine start process. If the propeller is in feather position, an overload on the electric engine starter will occur.

To prevent feathering during normal engine shutdown, the propeller incorporates spring-energized latch pins, called start locks. Two units are installed the cylinder. If propeller rotation is approximately 800 RPM or above, the start locks disengage from the piston by centrifugal force acting on the latch pins to compress the spring (within the units). When RPM drops below 800 RPM, the springs overcome the centrifugal force and move the latch pins to engage the piston, preventing blade angle movement to feather.

Shortly after start up with the propeller RPM above 800 the latch pins in the start locks will still retain the blade angle. To release the latch pins, it is necessary to manually actuate the propeller slightly toward reverse. This will move the piston, allowing the latch pins to slide freely. Centrifugal force will compress the springs and disengage the pins from the piston.

W10125

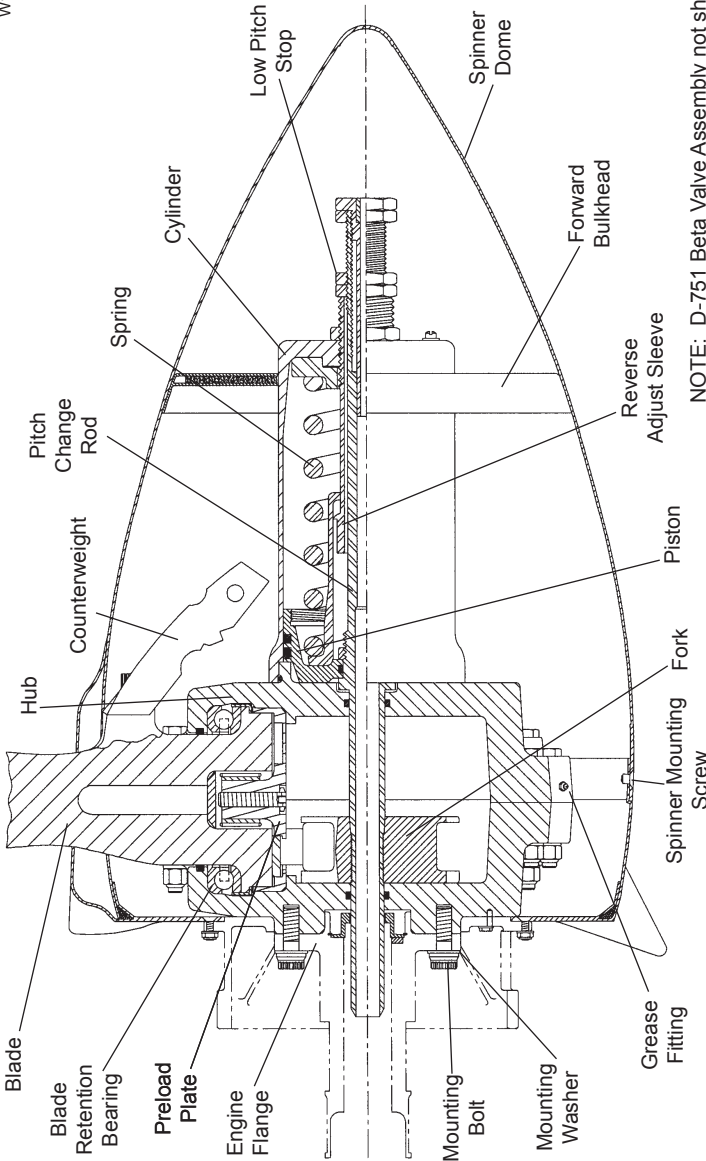

NOTE: D-751 Beta Valve Assembly not shown

**HC-D3F-7 Series Propeller
Figure 2-8**

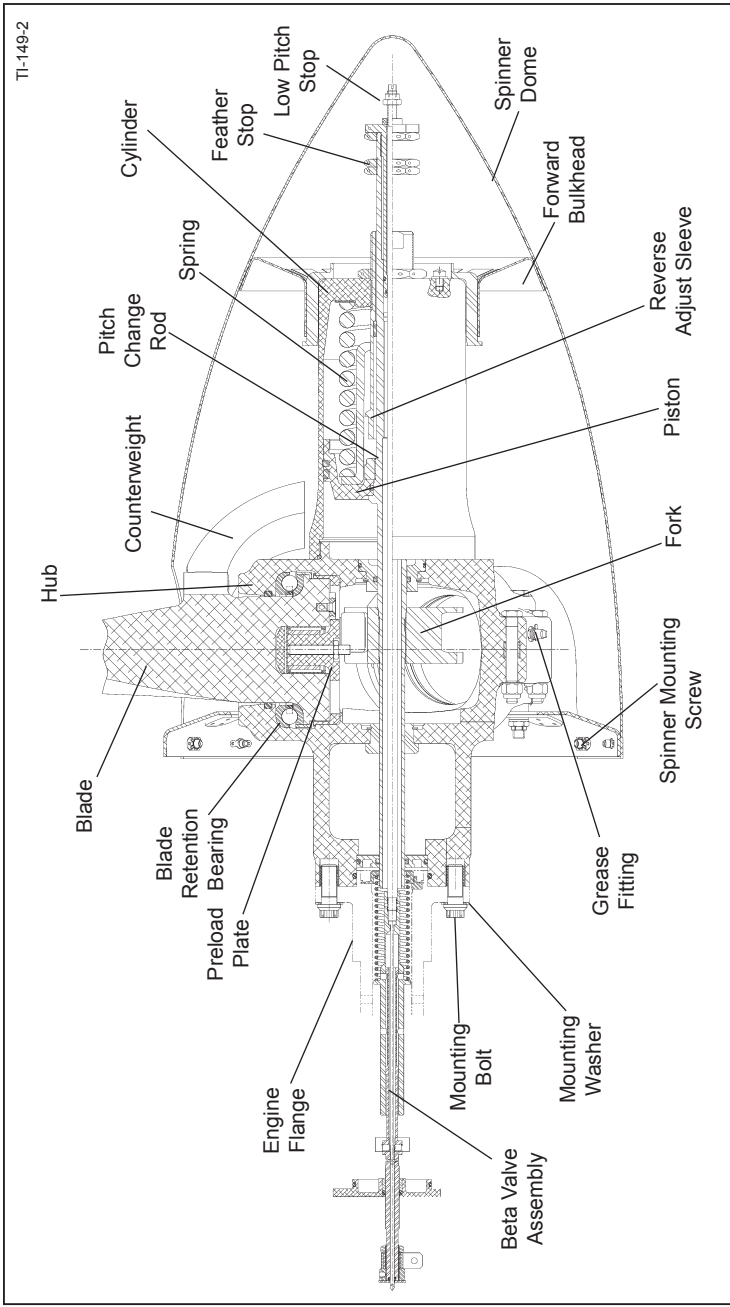

**HC-D3F-7H Series Propeller
Figure 2-9**

D. Feathering and Reversing Propellers HC-D3F-7() Series

Refer to Figure 2-8 and Figure 2-9. The propellers described in this section are constant speed, feathering and reversing. They use a single oil supply from a governing device to hydraulically actuate a change in blade angle. These propellers have three blades and are used primarily on Allison 250-B17() series turbine engines.

A two piece aluminum hub retains each propeller blade on a thrust bearing. A cylinder is attached to the hub and contains a feathering spring and piston. The hydraulically actuated piston transmits linear motion through a pitch change rod and fork to each blade to result in blade angle change.

While the propeller is operating, the following forces are constantly present: 1) spring force, 2) counterweight force, 3) centrifugal twisting moment of each blade and 4) blade aerodynamic twisting forces. The spring and counterweight forces attempt to rotate the blades to higher blade angle, while the centrifugal twisting moment of each blade is generally toward lower blade angle. Blade aerodynamic twisting force is usually very small in relation to the other forces and can attempt to increase or decrease blade angle.

The summation of the propeller forces is toward higher pitch (low RPM) and is opposed by a variable force toward lower pitch (high RPM). The variable force is oil under pressure from a governor with an internal pump, which is mounted on and driven by the engine. The oil from the governor is supplied to the propeller and hydraulic piston through a hollow engine shaft. Increasing the volume of oil within the piston and cylinder will decrease the blade angle and increase propeller RPM. Decreasing the volume of oil will increase blade angle and decrease propeller RPM. By changing blade angle the governor can vary the load on the engine and maintain constant engine RPM (within limits), independent of where the power lever is set. The governor uses engine speed sensing mechanisms that allow it to supply or drain oil as necessary to maintain constant engine speed (RPM).

If governor supplied oil is lost during operation, the propeller will increase pitch and feather. Feathering occurs because the summation of internal propeller forces causes the oil to drain out of the propeller until the feather stop position is reached.

Normal in-flight feathering is accomplished when the pilot retards the propeller condition lever past the feather detent. This allows control oil to drain from the propeller and return to the engine sump. Engine shutdown is normally accomplished during the feathering process.

Normal in-flight unfeathering is accomplished when the pilot positions the propeller condition lever into the normal flight (governing) range, activates the auxiliary pump to decrease blade pitch and restarts the engine. As engine speed increases, the governor supplies oil to the propeller and the blade angle decreases.

In reverse mode of operation the governor is operates in an underspeed condition to act strictly as a source of pressurized oil, without attempting to control RPM. Control of the propeller blade angle then becomes the responsibility of the beta valve.

NOTE: The beta valve is located inside the propeller and engine propeller shaft and protrudes from the gearbox on the side opposite from the propeller for control input connection.

The propeller is reversed by manually repositioning the cockpit-control to cause the beta valve to supply oil from the governor pump to the propeller. A rod that protrudes from the propeller piston communicates propeller blade angle position to the beta valve.

When the propeller reaches the desired reverse position, movement of the beta rod, initiated by the propeller piston, will cause the beta valve to shut off flow of oil to the propeller. Any additional unwanted movement of the propeller toward reverse or any movement of the manually positioned beta valve control toward high pitch position will cause the beta valve to drain oil from the propeller to increase pitch.

2. Model Designation

The following pages illustrate sample model designations for Hartzell lightweight propeller hub assemblies and blades. Hartzell uses a model designation to identify specific propeller and blade assemblies. Example: HC-D4N-5AL/D9327K. A slash mark separates the propeller and blade designations.

A. Aluminum Hub Propeller Model Identification

The propeller model designation is impression stamped on the propeller hub.

HC - D 4 N - 5 AL

MINOR MODIFICATIONS
SEE NEXT PAGE

2 - CONSTANT SPEED, FEATHERING, PT6A
3 - CONSTANT SPEED, FEATHERING, REVERSING
EXTERNAL BETA RING for P & W PT6A APPLICATIONS
5 - CONSTANT SPEED, FEATHERING, REVERSING,
INTERNAL BETA, START LOCKS, TPE-331
7 - CONSTANT SPEED, FEATHERING, REVERSING,
ALLISON ENGINES, BETA VALVE D-751

	BOLT CIRCLE	NO.	DOWELS DIA.	NO. OF BOLTS OR STUDS
A	5.125 in.	2	5/8	12 (9/16")
B	5.125 in.	2	5/8	12 (9/16")
F	4.00 in.	2	1/2	6 (1/2")
N	4.25 in.	2	1/2	8 (9/16")
P	4.25 in.	4	1/2	8 (9/16")
W	4.25 in.	4	1/2	8 (9/16")*

*HC-E4W-3() requires the use of a C-7620 spacer.

*HC-E4W-5L requires the use of 101058 propeller mounting shim

NO. OF BLADES **3, 4, or 5**

D - 3.4 INCH DIAMETER BLADE SHANK
E - SAME AS "D" EXCEPT DIFFERENT SHANK DIMENSIONS AND
INTERNAL BLADE BEARING

HC - HARTZELL CONTROLLABLE

HC - D 4 N - 5 AL

MINOR MODIFICATIONS
(up to 5 characters)

D3F-7:

BLANK - INITIAL PRODUCTION MODEL
H - INTEGRAL 4.25 SHAFT EXTENSION

D4N-2:

A - INITIAL PRODUCTION MODEL
AA - SAME AS "A" EXCEPT AIRCRAFT APPLICATION
D - SAME AS "A" EXCEPT ANGLE SETTING (SI 210)
DA - SAME AS "D" EXCEPT AIRCRAFT APPLICATION
E - SAME AS "D" EXCEPT HAS COMPRESSOR PULLEY
F - SAME AS "A" EXCEPT HAS COMPRESSOR PULLEY
G - SAME AS "AA" EXCEPT HAS COMPRESSOR PULLEY

D4N-3:

A - INITIAL PRODUCTION MODEL
C - SAME AS "A" EXCEPT BLADE, CTWT, APPLICATION
E - SAME AS "A" EXCEPT BLADE, CTWT, APPLICATION
G - SAME AS "A" EXCEPT BLADE, CTWT, APPLICATION
N - SAME AS "A" EXCEPT BLADE, CTWT, APPLICATION
Q - SAME AS "A" EXCEPT BLADE, CTWT, APPLICATION
P - SAME AS "A" EXCEPT BLADE, CTWT, APPLICATION
R - SAME AS "A" EXCEPT BLADE, CTWT, APPLICATION
T - SAME AS "A" EXCEPT BLADE, CTWT, APPLICATION

D4N-5:

C - INITIAL PRODUCTION MODEL
E - SAME AS "C" EXCEPT FOR CYLINDER
AL - SAME AS "C" EXCEPT BLADE, CTWT, APPLICATION

D4P-5:

BLANK - INITIAL PRODUCTION MODEL
L - LEFT HAND ROTATION

E4A-2:

BLANK - INITIAL PRODUCTION MODEL
A - SAME AS -2 EXCEPTSION BLADE, APPLICATION

E4A-3:

D - INITIAL PRODUCTION MODEL
M - SAME AS "D" EXCEPT BLADE, HUB UNIT, CTWT, APPLICATION

E4N-2:

BLANK - INITIAL PRODUCTION MODEL

E4N-3:

BLANK - INITIAL PRODUCTION MODEL
G - SAME AS -3 EXCEPT BLADE, CTWT, APPLICATION
H - SAME AS -3 EXCEPT BLADE, CTWT, APPLICATION
I - SAME AS -3 EXCEPT BLADE, CTWT, APPLICATION
N - SAME AS -3 EXCEPT BLADE, CTWT, APPLICATION
P - SAME AS -3 EXCEPT BLADE, CTWT, APPLICATION
PY - SAME AS -3 EXCEPT OPTIONAL START LOCKS
Q - SAME AS -3 EXCEPT BLADE, CTWT, APPLICATION

E4N-5:

A - INITIAL PRODUCTION MODEL
B - SAME AS "A" EXCEPT PITCH ROD
D - SAME AS "A" EXCEPT BLADE, CTWT, APPLICATION

E4W-3:

BLANK - INITIAL PRODUCTION MODEL
A - SAME AS -3 EXCEPT BLADE SHANK

E4W-5:

L - LEFT HAND ROTATION

E5N-3:

BLANK - INITIAL PRODUCTION MODEL
L - SAME AS -3 EXCEPT LEFT HAND ROTATION
A - SAME AS -3 EXCEPT HUB UNIT
AL - SAME AS "A" EXCEPT LEFT HAND ROTATION

B. Aluminum Blade Model Identification

The blade designation is impression stamped on the blade butt end (internal) and is either on a decal or ink stamped on the blade camber side (external).

prop model/E9512CB-1

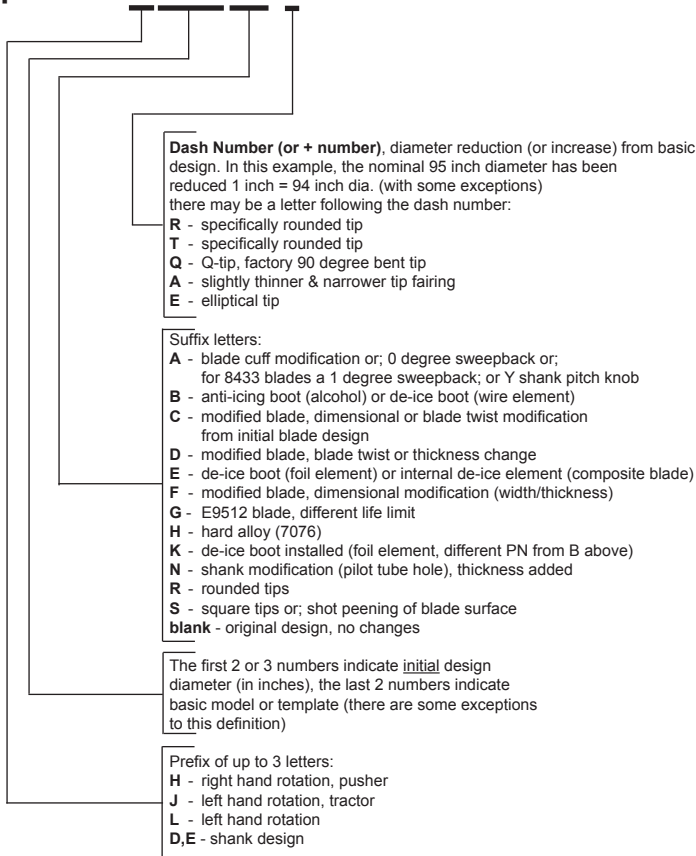

(This page is intentionally blank.)

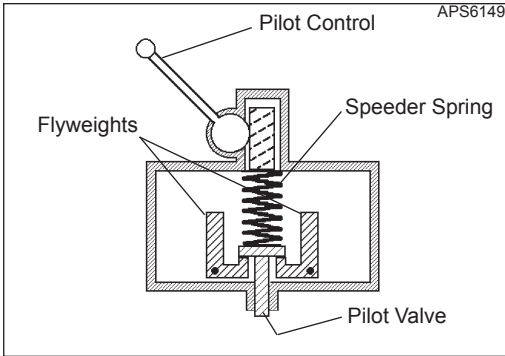

Governor in Onspeed Condition
Figure 2-10

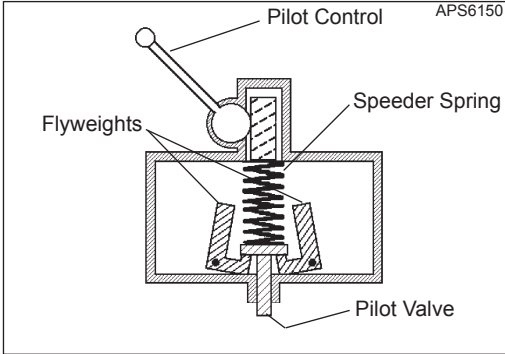

Governor in Underspeed Condition
Figure 2-11

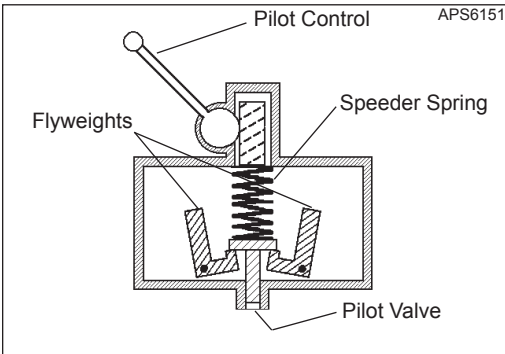

Governor in Overspeed Condition
Figure 2-12

3. Governors**A. Theory of Operation**

- (1) A governor is an engine RPM sensing device and high pressure oil pump. In a constant speed propeller system, the governor responds to a change in engine RPM by directing oil under pressure to the propeller hydraulic cylinder or by releasing oil from the hydraulic cylinder. The change in oil volume in the hydraulic cylinder changes the blade angle and maintains the propeller system RPM to the set value. The governor is set for a specific RPM via the cockpit propeller control that compresses or releases the governor speeder spring.
- (2) When the engine is operating at the RPM set by the pilot using the cockpit control, the governor is operating **onspeed**. Refer to Figure 2-10. In an onspeed condition, the centrifugal force acting on the flyweights is balanced by the speeder spring, and the pilot valve is neither directing oil to nor from the propeller hydraulic cylinder.
- (3) When the engine is operating below the RPM set by the pilot using the cockpit control, the governor is operating **underspeed**. Refer to Figure 2-11. In an underspeed condition, the flyweights tilt inward because there is not enough centrifugal force on the flyweights to overcome the force of the speeder spring. The pilot valve, forced down by the speeder spring, meters oil flow to decrease propeller pitch and raise engine RPM.
- (4) When the engine is operating above the RPM set by the pilot using the cockpit control, the governor is operating **overspeed**. Refer to Figure 2-12. In an overspeed condition, the centrifugal force acting on the flyweights is greater than the speeder spring force. The flyweights tilt outward, and raise the pilot valve. The pilot valve then meters oil flow to increase propeller pitch and lower engine RPM.

- (5) Feathering governors allow oil to be pushed from the propeller to the engine drain to increase propeller pitch to feather.
- (6) A synchronizing system can be employed in a multi-engine aircraft to keep the engines operating at the same RPM. A synchrophasing system not only keeps RPM of the engines consistent, but also keeps the propeller blades operating in phase with each other. Both synchronizing and synchrophasing systems serve to reduce noise and vibration.

4. Propeller Ice Protection Systems

A Hartzell Propeller Inc. turbine propeller may be equipped with an anti-ice or de-ice system. A short description of each of these systems follows:

A. Propeller Anti-ice System

A propeller anti-ice system is a system that prevents ice from forming on propeller surfaces. The system dispenses an anti-icing fluid (usually isopropyl alcohol) which mixes with moisture on the propeller blades, reducing the freezing point of the water. The water/alcohol mixture flows off of the blades before ice forms. This system must be in use before ice forms. It is ineffective in removing ice that has already formed.

(1) System Overview

- (a) A typical anti-ice system consists of a fluid tank, pump, and distribution tubing.
- (b) The rate at which the anti-icing fluid is dispensed is controlled by a pump speed rheostat in the cockpit.
- (c) The anti-icing fluid is dispensed through airframe mounted distribution tubing and into a rotating slinger ring mounted on the rear of the propeller hub. The anti-icing fluid is then directed through blade feed tubes from the slinger ring onto the blades via centrifugal force. The anti-icing fluid is directed onto anti-icing boots that are attached to the leading edge of the blade. These anti-icing boots evenly distribute and direct the fluid along the blade leading edge.

B. Propeller De-ice System

A propeller de-ice system is a system that allows ice to form, and then removes it by electrically heating the de-ice boots. The ice partially melts and is thrown from the blade by centrifugal force.

(1) System Overview

- (a) A de-ice system consists of one or more on/off switches, a timer or cycling unit, a slip ring and brush blocks, and de-icing boots. The pilot controls the operation of the de-icing system by turning on one or more switches. All de-ice systems have a master switch, and may have another toggle switch for each propeller. Some systems also have a selector switch to adjust for light or heavy icing conditions.
- (b) The timer or cycling unit determines the sequence of which blades (or portion thereof) are currently being de-iced, and for what length of time. The timer controls the application of power to each de-ice boot or boot segment in a sequential order.
- (c) A brush block, which is normally mounted on the engine just behind the propeller, is used to transfer electricity to the slip ring. The slip ring rotates with the propeller, and provides a current path to the blade de-ice boots.
- (d) De-ice boots contain internal heating elements. These boots are securely attached to the leading edges of each blade with adhesive.

(This page is intentionally blank.)

INSTALLATION AND REMOVAL - CONTENTS

1. Tools, Consumables, and Expendables	3-5
A. General.....	3-5
B. Tooling	3-5
C. Consumables	3-6
D. Expendables.....	3-6
2. Pre-Installation.....	3-6
A. Inspection of Shipping Package	3-6
B. Uncrating	3-6
C. Inspection after Shipment.....	3-6
D. Reassembly of a Propeller Disassembled for Shipment ..	3-6
3. Propeller Assembly Installation.....	3-7
A. Precautions	3-7
B. Installing the HC-(D,E)4()-2() Propeller on the Aircraft Engine.....	3-11
C. Installing the HC-(D,E)(4,5)(A,N)-3() Propeller on the Aircraft	3-21
C1. Installing the HC-E4P-3K Propeller on the Aircraft Engine	3-24.2
D. Installing the HC-E4W-3() Propeller on the Aircraft Engine.....	3-25
E. Installing the HC-E4W-5L Propeller on the Aircraft Engine.....	3-33
F. Installing the HC-(D,E)4()-5() Propeller on the Aircraft Engine, Except HC-E4W-5L.....	3-37
G. Installing the HC-D3F-7() Propeller on the Allison Engine.....	3-44
4. Spinner Dome Installation	3-52.1
A. General.....	3-52.1
B. Propeller Models HC-(D,E)4()-(2,3,5)(), HC-E5N-3(), and HC-D3F-7H That Use a One-piece Spinner Dome and Forward Bulkhead	3-52.1
C. Propeller Models HC-E5N-3() with D-5527-1() Spinner Assembly.....	3-55

CONTENTS (CONTINUED)

D. Propeller Model HC-D3F-7 Installed on Goodyear Airship GZ-22	3-55
5. Post-Installation Checks	3-56
6. Spinner Dome Removal	3-56
7. Propeller Assembly Removal.....	3-57
A. Removal of HC-(D,E)4()-2() Propellers	3-57
B. Removal of HC-(D,E)(4,5)(A,N)-3() Propellers except HC-E4P-3K	3-60
B1. Removal of HC-E4P-3K Propellers	3-62.1
C. Removal of HC-E4W-3() Propellers	3-63
D. Removal of HC-E4W-5L Propellers.....	3-66
E. Removal of HC-(D,E)4()-5() Propellers, except E4W-5L	3-69
F. Removal of HC-D3F-7() Propellers	3-72
G. Removal of the D-751-() Beta Valve Assembly	3-75

LIST OF FIGURES

Air Conditioning Drive Accessories.....	Figure 3-1	3-8
Installing Propeller on Engine Flange.....	Figure 3-2	3-12
Mounting Bolt and Washer	Figure 3-3	3-13
Determining Torque Value When Using Torquing Adapter	Figure 3-4	3-14
Diagram of Torquing Sequence for Propeller Mounting Bolts.....	Figure 3-5	3-15
Tool for Decompressing HC-(D,E)(4,5)()-3() Series External Beta System.....	Figure 3-6	3-20
Carbon Block and Beta Ring Clearance.....	Figure 3-7	3-22
Carbon Block Assembly.....	Figure 3-8	3-22
Hub-to-Spacer O-ring Location in the Spacer .	Figure 3-9	3-26
Installing the HC-E4W-3() Propeller on Engine Flange	Figure 3-10	3-28

LIST OF FIGURES (CONTINUED)

Installing the Washer on the Mounting Stud....	Figure 3-11	3-30
Installing the HC-E4W-5L Propeller on Engine Flange	Figure 3-12	3-32
Beta Valve System	Figure 3-13	3-40
Beta Valve System in the Propeller	Figure 3-14	3-41
Front View of the Beta Valve System in the Propeller	Figure 3-15	3-42
Rear View of the Beta Valve System in the Propeller	Figure 3-16	3-43
Filed Rod for Set Screw.....	Figure 3-17	3-47
Spinner Assembly for HC-(D,E)4()-(2,3,5)() and HC-E5N-3() with D-5505-1() Spinner Assembly.....	Figure 3-18	3-50
Spinner Reassembly Procedures	Figure 3-19	3-51
Optional Tape on the Spinner Forward Bulkhead	Figure 3-19.1	3-52
D-5527-1() Spinner Assembly	Figure 3-20	3-54

LIST OF TABLES

Propeller/Engine Flange O-rings and Mounting Hardware	Table 3-1	3-9
Torque Table	Table 3-2	3-16

(This page is intentionally blank.)

1. Tools, Consumables, and Expendables**A. General**

- (1) The following tools, consumables, and expendables are required for propeller removal or installation:

B. Tooling**A Flange**

- Safety wire pliers (Alternate: Safety cable tool)
- Torque wrench
- Torque wrench adapter (Hartzell Propeller Inc. P/N AST-2877)

F Flange

- Safety wire pliers (Alternate: Safety cable tool)
- Torque wrench
- Torque wrench adapter (Hartzell Propeller Inc. P/N AST-2917)

N Flange

- Safety wire pliers (Alternate: Safety cable tool)
- Torque wrench
- Torque wrench adapter (Hartzell Propeller Inc. P/N AST-2877)

P Flange

- Safety wire pliers (Alternate: Safety cable tool)
- Torque wrench
- Torque wrench adapter
(Hartzell Propeller Inc. P/N AST-2877 that use bolt)
(Hartzell Propeller Inc. P/N AST-2877-1 that use nut)

W Flange

- Torque wrench adapter (Hartzell Propeller Inc. P/N AST-3175)
- Torque check tool (Hartzell Propeller Inc. P/N AST-2968-1)
- Feeler gage
- Beta system puller (Hartzell Propeller Inc. P/N CST-2987)
- 5/8 inch deep well socket
- 1-7/16 inch crowfoot wrench

- C. Consumables
 - Quick Dry Stoddard Solvent or Methyl-Ethyl-Ketone (MEK)
- D. Expendables
 - 0.032 inch (0.81 mm) Stainless Steel Aircraft Safety wire (Alternate: 0.032 inch [0.81 mm] aircraft safety cable and associated washers and ferrules)
 - O-ring, Propeller-to-Engine Seal (see Table 3-1)

2. Pre-Installation

A. Inspection of Shipping Package

- (1) Examine the exterior of the shipping container for signs of shipping damage, especially at the box ends around each blade. A hole, tear or crushed appearance at the end of the box (blade tips) may indicate the propeller was dropped during shipment, possibly damaging the blades.

B. Uncrating

- (1) Put the propeller on a firm support.
- (2) Remove the banding and any external wood bracing from the shipping container.
- (3) Remove the cardboard from the hub and blades.

CAUTION: DO NOT STAND THE PROPELLER ON A BLADE TIP.

- (4) Put the propeller on a padded surface that supports the propeller over a large area.
- (5) Remove the plastic dust cover cup from the propeller mounting flange (if installed).

C. Inspection after Shipment

- (1) After removing the propeller from the shipping container, examine the propeller components for shipping damage.

D. Reassembly of a Propeller Disassembled for Shipment

- (1) If a propeller was received disassembled for shipment, it is to be reassembled by trained personnel in accordance with the applicable propeller maintenance manual.

3. Propeller Assembly Installation

CAUTION: INSTRUCTIONS AND PROCEDURES IN THIS SECTION MAY INVOLVE PROPELLER CRITICAL PARTS. REFER TO THE INTRODUCTION CHAPTER OF THIS MANUAL FOR INFORMATION ABOUT PROPELLER CRITICAL PARTS. REFER TO THE ILLUSTRATED PARTS LIST CHAPTER OF THE APPLICABLE OVERHAUL MANUAL(S) FOR THE IDENTIFICATION OF SPECIFIC PROPELLER CRITICAL PARTS.

A. Precautions

WARNING 1: DURING ENGINE INSTALLATION OR REMOVAL, USING THE PROPELLER TO SUPPORT THE WEIGHT OF THE ENGINE IS NOT AUTHORIZED. UNAPPROVED INSTALLATION AND REMOVAL TECHNIQUES MAY CAUSE DAMAGE TO THE PROPELLER, WHICH MAY LEAD TO FAILURE RESULTING IN AN AIRCRAFT ACCIDENT.

WARNING 2: WHEN INSTALLING THE PROPELLER, FOLLOW THE AIRFRAME MANUFACTURER'S MANUALS AND PROCEDURES, AS THEY MAY CONTAIN ISSUES VITAL TO AIRCRAFT SAFETY THAT ARE NOT CONTAINED IN THIS OWNER'S MANUAL.

CAUTION: AVOID THE USE OF BLADE PADDLES. DO NOT PUT THE BLADE PADDLE IN THE AREA OF THE DE-ICE BOOT WHEN APPLYING TORQUE TO A BLADE ASSEMBLY. PUT THE BLADE PADDLE IN THE THICKEST AREA OF THE BLADE, JUST OUTSIDE OF THE DE-ICE BOOT. USE ONE BLADE PADDLE PER BLADE.

- (1) Be sure the propeller is removed before the engine is removed or installed in the airframe.

TI-0104

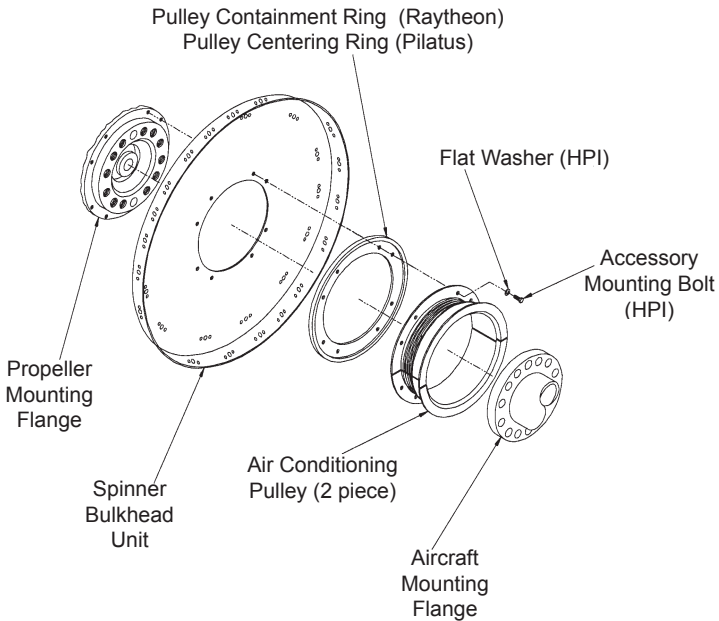

Part	Raytheon T6A HC-E4A-2()	Pilatus PC-9 HC-D4N-2(E,F,G)
Air Conditioning Pulley	133-910029-7	PC9-1401-2
Pulley Containment Ring	133-910029-11	NA
Pulley Centering Ring w/ De-ice	NA	PC9-1401-1
Pulley Centering Ring w/o De-ice	NA	PC9-1401
Accessory Mounting Bolt	(HPI Part) B-3384-8H	(HPI Part) B-3384-9H *
Accessory Mounting Washer	(HPI Part) B-3851-0463	(HPI Part) B-3851-0463

* Propeller is built using bolt (HPI Part) B-3384-6H to hold the bulkhead on the propeller. When the propeller is installed on the aircraft, use mounting bolt (HPI Part) B-3384-9H (pulley only).

**Air Conditioning Drive Accessories
Figure 3-1**

- (2) Follow the airframe manufacturer's instructions for installing the propeller.
 - (a) If such instructions are not in the airframe manufacturer's manual, then follow the instructions in this manual; however, mechanics must consider that this owner's manual does not describe important procedures that are outside the scope of this manual.
 - (b) In addition to propeller installation procedures, items such as rigging and preflight testing of flight idle blade angle, and propeller synchronization devices are normally found in the airframe manufacturer's manuals.

Flange	O-ring	Bolt/Stud	Washer	Nut	Misc
A	C-3317-239-2	B-3347	A-2048-2	---	
F	C-3317-228	A-1328	A-1381	---	
N	C-3317-230	B-3339-1	A-2048-2	---	
P except for Pratt engine	C-3317-230	B-3347	A-2048-2	---	
P Pratt engine, except for HC-E4P-3K	C-3317-230	B-3339-1	A-2048-2	---	
HC-E4P-3K	C-3317-230	103560	A-2048-2	C-6006	
W (HC-E4W-3[A])	C-3317-230 (Spacer-to-engine) C-3317-233 (Hub-to-spacer)	A-3254	B-7624	B-7458	C-7620 Spacer B-3868-S52 Screw
W (HC-E4W-5L)	C-3317-230	A-3254	B-7624	B-7458	101058 Propeller Mounting Shim

**Propeller/Engine Flange O-rings and Mounting Hardware
Table 3-1**

(This page is intentionally blank.)

B. Installing the HC-(D,E)4()-2() Propeller on the Aircraft Engine

WARNING: MAKE SURE THE SLING IS RATED UP TO 800 LBS (363 KG) TO SUPPORT THE WEIGHT OF THE PROPELLER ASSEMBLY DURING REMOVAL.

CAUTION 1: WHEN INSTALLING THE PROPELLER ON THE AIRCRAFT, DO NOT DAMAGE THE ICE PROTECTION SYSTEM COMPONENTS, IF APPLICABLE.

CAUTION 2: INSTRUCTIONS AND PROCEDURES IN THIS SECTION MAY INVOLVE PROPELLER CRITICAL PARTS. REFER TO THE INTRODUCTION CHAPTER OF THIS MANUAL FOR INFORMATION ABOUT PROPELLER CRITICAL PARTS. REFER TO THE ILLUSTRATED PARTS LIST CHAPTER OF THE APPLICABLE OVERHAUL MANUAL(S) FOR THE IDENTIFICATION OF SPECIFIC PROPELLER CRITICAL PARTS.

- (1) With a suitable crane hoist and sling, carefully move the propeller assembly to the aircraft engine mounting flange.
 - (a) Some propellers may require installation of an accessory drive pulley. If installation procedures are not in this manual, refer to the aircraft manufacturer's instructions.
- (2) Using Quick Dry Stoddard Solvent or MEK, clean the engine flange and the propeller flange.
- (3) Remove the pitch change rod cap, if applicable.
- (4) Install the specified O-ring on the engine flange. Refer to Table 3-1.
- (5) For propeller models with air conditioning accessories, refer to Figure 3-1.
 - (a) Temporarily attach the spinner bulkhead and pulley containment ring to the propeller hub with two of the separately packaged accessory mounting bolts.

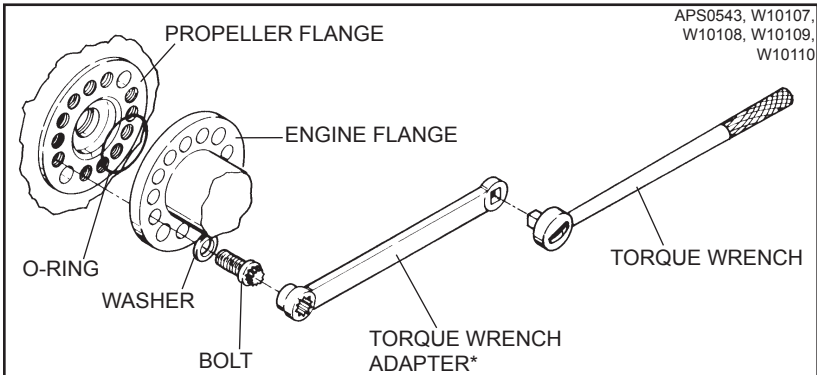

***NOTE:** If a torque wrench adapter is used, use the calculation in Figure 3-4 to determine the correct torque wrench setting.

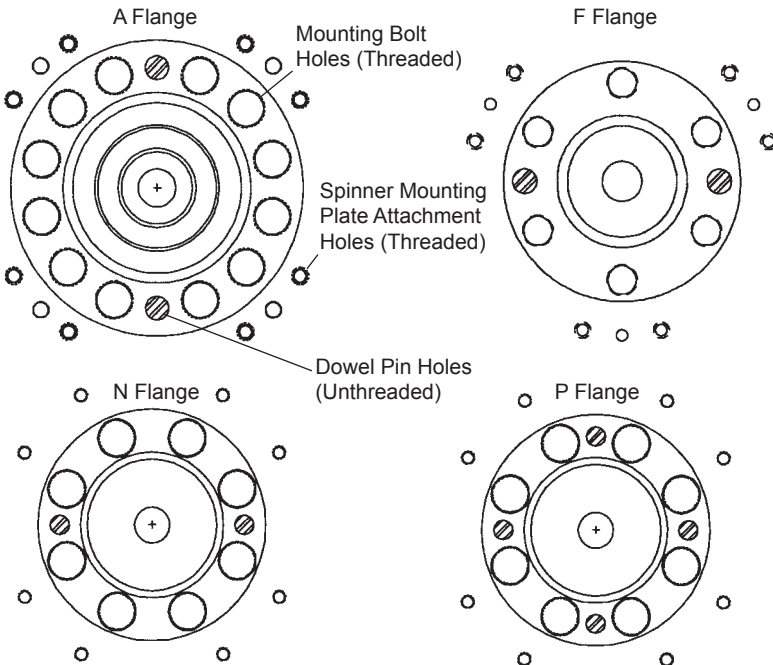

**Installing Propeller on Engine Flange
Figure 3-2**

(6) Align mounting and dowel pin holes in the propeller hub flange with the mounting holes and dowel pins in the engine flange.

(7) Slide the propeller flange onto the engine flange.

CAUTION 1: MAKE SURE THAT COMPLETE AND TRUE SURFACE CONTACT IS ESTABLISHED BETWEEN THE PROPELLER HUB FLANGE AND THE ENGINE FLANGE.

CAUTION 2: NEW PROPELLER MOUNTING BOLTS MUST BE USED WHEN INITIALLY INSTALLING A NEW OR OVERHAULED PROPELLER.

(8) Apply a MIL-PRF-83483() anti-seize compound to the threaded surfaces of the mounting bolts. Refer to Table 3-1 for the applicable mounting hardware.

(a) If the propeller is removed between overhaul intervals, mounting bolts and washers may be reused if they are not damaged or corroded.

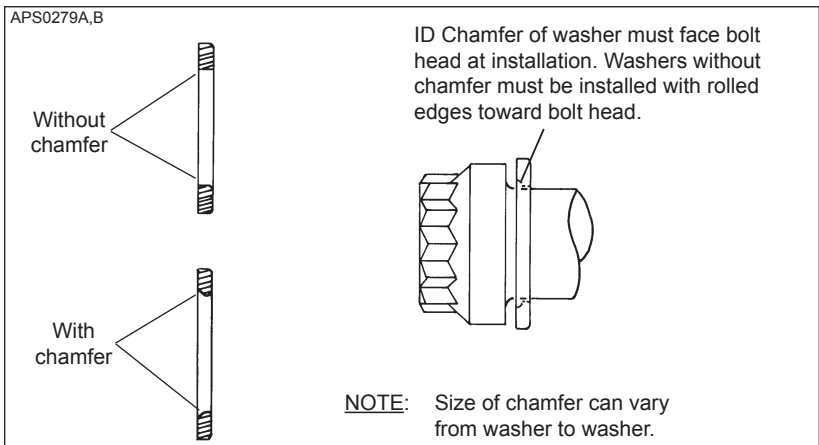

**Mounting Bolt and Washer
Figure 3-3**

APS0212A

Standard Torque Wrench

Torquing Adapter

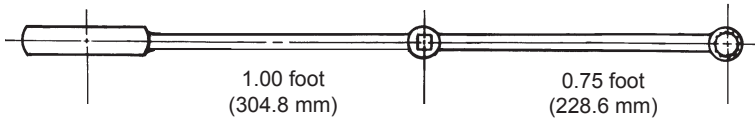

$$\frac{(\text{actual torque required}) \times (\text{torque wrench length})}{(\text{torque wrench length}) + (\text{length of adapter})} = \text{Torque wrench reading to achieve required actual torque}$$

EXAMPLE:

$$\frac{100 \text{ Ft-Lb (136 N}\cdot\text{m)} \times 1 \text{ ft (305 mm)}}{1 \text{ ft (304.8 mm)} + 0.75 \text{ ft (228.6 mm)}} = \frac{57.1.7 \text{ Ft-Lb (77.4 N}\cdot\text{m)}}{}$$

reading on torque wrench with 9-inch (228.6 mm) adapter for actual torque of 100 Ft-Lb (136 N·m)

The correction shown is for an adapter that is aligned with the centerline of the torque wrench. If the adapter is angled 90 degrees relative to the torque wrench centerline, the torque wrench reading and actual torque applied will be equal.

**Determining Torque Value When Using Torquing Adapter
Figure 3-4**

W10107C.
W10107B.
W10108C.
W10109C.
W10109B.

A or B Flange

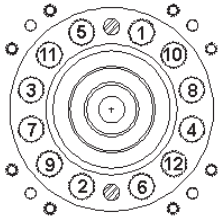

SEQUENCE A

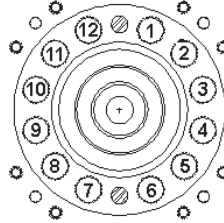

SEQUENCE B

Use Sequence A for steps one and two.

Use Sequence B for step three.

Step 1 - Torque all bolts to 40 Ft-Lbs (54 N•m). **Step 3** - Torque all bolts to Table 3-2.
Step 2 - Torque all bolts to 80 Ft-Lbs (108 N•m).

F Flange

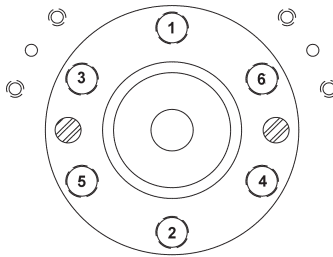

Step 1 - Torque all bolts to 40 Ft-Lbs (54 N•m).
Step 2 - Torque all bolts to Table 3-2.

N, P or W Flange

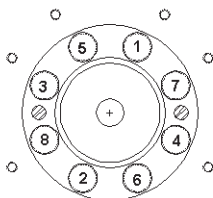

SEQUENCE A

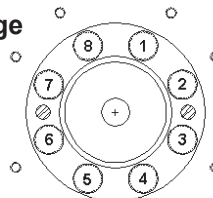

SEQUENCE B

Use Sequence A for steps one and two.

Use Sequence B for step three.

Step 1 - Torque all bolts to 40 Ft-Lbs (54 N•m). **Step 3** - Torque all bolts to Table 3-2.
Step 2 - Torque all bolts to 80 Ft-Lbs (108 N•m).

**Diagram of Torquing Sequence for Propeller Mounting Bolts
Figure 3-5**

CAUTION: ID CHAMFER OF WASHER MUST BE FACING TOWARD THE BOLT HEAD. WASHERS WITHOUT CHAMFER MUST BE INSTALLED WITH ROLLED EDGES TOWARD THE BOLT HEAD. (REFER TO FIGURE 3-3).

(9) Install the mounting bolts with washers through the engine flange and into the propeller hub flange. Refer to Figure 3-2.

CAUTION 1:	FOR A PROPELLER THAT DOES NOT USE A LUBRICATED (WET) TORQUE, THE MOUNTING HARDWARE MUST BE CLEAN AND DRY TO PREVENT EXCESSIVE PRELOAD OF THE MOUNTING FLANGE.
CAUTION 2:	TORQUE VALUES WITH "WET" NOTED AFTER THEM ARE BASED ON LUBRICATED THREADS WITH APPROVED ANTI-SEIZE COMPOUND MIL-PRF-83483().
CAUTION 3:	REFER TO FIGURE 3-4 FOR TORQUE READING WHEN USING A TORQUE WRENCH ADAPTER.
Accessory mounting. bolts	36-44 In-Lbs (4.1-4.9 N•m) Wet
A flange propeller mounting bolts	100-105 Ft-Lbs (136-142 N•m) Wet
F flange propeller mounting bolts	80-90 Ft-Lbs (108-122 N•m)
N flange propeller mounting bolts	100-105 Ft-Lbs (136-142 N•m) Wet
P flange propeller mounting bolts except HC-E4P-3K	100-105 Ft-Lbs (136-142 N•m) Wet
P flange propeller mounting nuts HC-E4P-3K	120-130 Ft-Lbs (163-176 N•m) Wet
W flange propeller mounting nuts	120-125 Ft-Lbs (163-170 N•m)

**Torque Table
Table 3-2**

- (10) Using a torque wrench and a torque wrench adapter Hartzell Propeller Inc. P/N AST-2877, torque all mounting bolts in sequences and steps shown in Figure 3-5. Refer to Table 3-2 and Figure 3-4 to determine the proper torque value.
- (11) Safety all mounting bolts with 0.032 inch (0.81 mm) minimum diameter stainless steel wire, two bolts per safety.
- (12) For propeller models with air conditioning accessories:
 - (a) Remove the two accessory mounting bolts temporarily attaching the spinner bulkhead and pulley containment ring to the propeller hub.
 - (b) With the eight separately packaged accessory mounting bolts and washers, attach the spinner bulkhead, pulley containment ring and air conditioning pulley onto the propeller hub. Refer to Figure 3-1.
 - (c) Torque bolts in accordance with Table 3-2.
 - (d) Safety wire the accessory mounting bolts.
- (13) If the propeller is equipped with an accessory drive pulley, follow the applicable manufacturer's instructions for installation of the accessory drive pulley hardware.
- (14) If the propeller is equipped with an ice protection system that uses components supplied by Hartzell Propeller Inc., applicable instructions and technical information for the components supplied by Hartzell Propeller Inc. can be found in the following publications available on the Hartzell Propeller Inc. website at www.hartzellprop.com:
 - (a) Hartzell Propeller Inc. Manual 180 (30-61-80) - Propeller Ice Protection System Manual
 - (b) Hartzell Propeller Inc. Manual 181 (30-60-81) - Propeller Ice Protection Component Maintenance Manual
 - (c) Hartzell Propeller Inc. Manual 182 (61-12-82) - Propeller Electrical De-ice Boot Removal and Installation Manual
 - (d) Hartzell Propeller Inc. Manual 183 (61-12-83) - Propeller Anti-icing Boot Removal and Installation Manual

- (15) Propeller ice protection system components not supplied by Hartzell Propeller Inc. are controlled by the applicable TC or STC holder's Instructions for Continued Airworthiness (ICA).
- (16) Install the propeller spinner dome in accordance with the section "Spinner Dome Installation" in this chapter.

(This page is intentionally blank.)

W10115
W10171

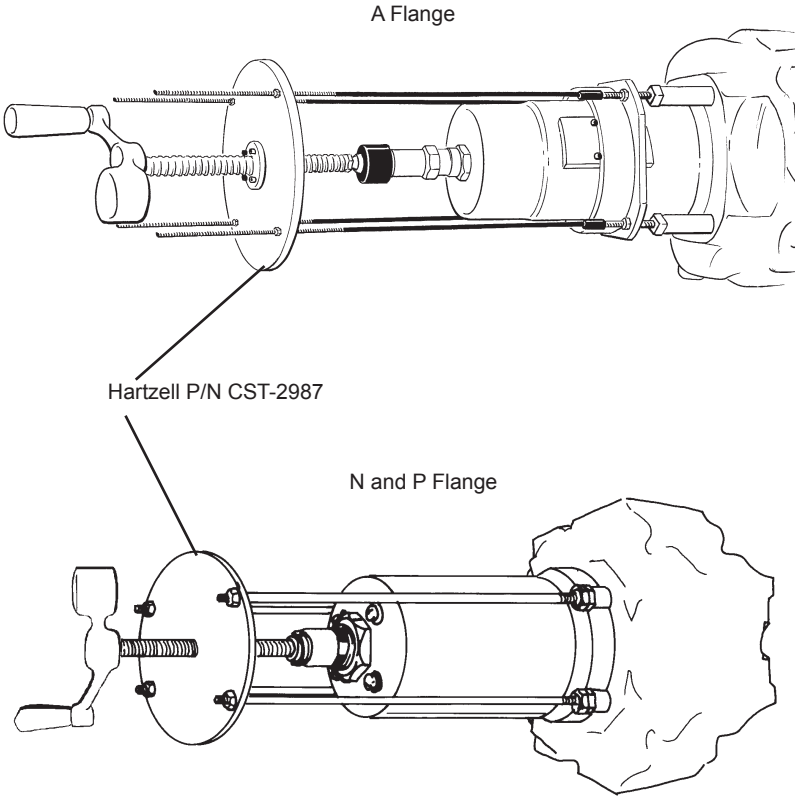

**Tool for Decompressing HC-(D,E)(4,5)()-3() Series
External Beta System
Figure 3-6**

C. Installing the HC-(D,E)(4,5)(A,N)-3() Propeller on the Aircraft Engine

- (1) Using a beta system puller CST-2987 (Figure 3-6), compress the beta system and pull the beta ring forward to permit installation of the double hex head propeller mounting bolts.

WARNING: MAKE SURE THE SLING IS RATED UP TO 800 LBS (363 KG) TO SUPPORT THE WEIGHT OF THE PROPELLER ASSEMBLY DURING INSTALLATION.

CAUTION 1: WHEN INSTALLING THE PROPELLER ON THE AIRCRAFT, DO NOT DAMAGE THE ICE PROTECTION SYSTEM COMPONENTS, IF APPLICABLE.

CAUTION 2: DO NOT CONTACT THE ANTI-ICE TRAVEL TUBES WITH THE SLING WHEN LIFTING THE PROPELLER.

CAUTION 3: INSTRUCTIONS AND PROCEDURES IN THIS SECTION MAY INVOLVE PROPELLER CRITICAL PARTS. REFER TO THE INTRODUCTION CHAPTER OF THIS MANUAL FOR INFORMATION ABOUT PROPELLER CRITICAL PARTS. REFER TO THE ILLUSTRATED PARTS LIST CHAPTER OF THE APPLICABLE OVERHAUL MANUAL(S) FOR THE IDENTIFICATION OF SPECIFIC PROPELLER CRITICAL PARTS.

- (2) With a suitable crane hoist and sling, carefully move the propeller assembly to the aircraft engine mounting flange.
 - (a) Some propellers may require installation of an accessory drive pulley. If installation procedures are not in this manual, refer to the aircraft manufacturer's instructions.
- (3) Using Quick Dry Stoddard Solvent or MEK, clean the engine flange and the propeller flange.
- (4) Remove the pitch change rod cap, if applicable.

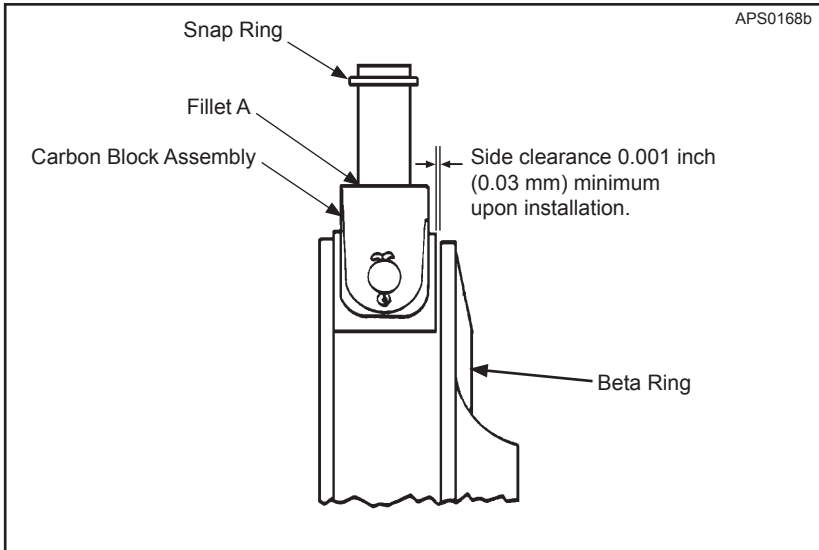

Carbon Block and Beta Ring Clearance
Figure 3-7

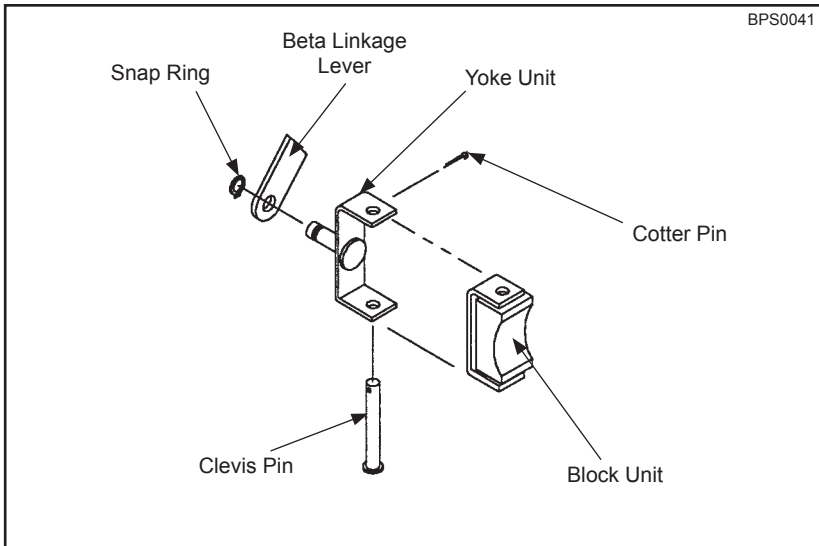

Carbon Block Assembly
Figure 3-8

- (5) Install the specified O-ring on the engine flange. Refer to Table 3-1.
- (6) Align the mounting and dowel pin holes in the propeller hub flange with the mounting holes and dowel pins in the engine flange.
- (7) Slide the propeller onto the engine flange.

CAUTION 1: MAKE SURE THAT COMPLETE AND TRUE SURFACE CONTACT IS ESTABLISHED BETWEEN THE PROPELLER HUB FLANGE AND THE ENGINE FLANGE.

CAUTION 2: NEW PROPELLER MOUNTING BOLTS MUST BE USED WHEN INITIALLY INSTALLING A NEW OR OVERHAULED PROPELLER.

- (8) Apply a MIL-PRF-83483() anti-seize compound to the threaded surfaces of the mounting bolts. Refer to Table 3-1 for the applicable mounting hardware.
 - (a) If the propeller is removed between overhaul intervals, mounting bolts and washers may be reused if they are not damaged or corroded.

CAUTION: ID CHAMFER OF WASHER MUST BE FACING TOWARD THE BOLT HEAD. WASHERS WITHOUT CHAMFER MUST BE INSTALLED WITH ROLLED EDGES TOWARD THE BOLT HEAD. (REFER TO FIGURE 3-3).

- (9) Install the mounting bolts with washers through the engine flange and into the propeller hub flange. Refer to Figure 3-2.
- (10) Using a torque wrench and a torque wrench adapter Hartzell Propeller Inc. P/N AST-2877, torque all mounting bolts in sequences and steps shown in Figure 3-5. Refer to Table 3-2 and Figure 3-4 to determine the proper torque value.
- (11) Safety all mounting bolts with 0.032 inch (0.81 mm) minimum diameter stainless steel wire or equivalent aircraft safety cable. (Two bolts per safety.)
- (12) Decompress the external beta system and remove the beta system puller.

CAUTION: THE BETA FEEDBACK COLLAR MUST NOT CONTACT ANY ENGINE COMPONENT OR MOUNTING BOLT SAFETY WIRE. THE BETA FEEDBACK MECHANISM COULD BE DAMAGED IF IT CONTACTED ANY STATIC ENGINE COMPONENT WHILE ROTATING.

- (13) Examine the beta feedback collar to make sure that it is not in contact with any engine components or mounting bolt safety wire.
- (a) If there is contact between the beta feedback collar and any engine components or mounting bolt safety wire, consult qualified personnel at an appropriately licensed propeller service facility.
- (14) Install the carbon block into the beta linkage lever, in accordance with the airframe manufacturer's instructions.
- (a) If the beta linkage lever and the snap ring are not installed correctly, there may be interference between the beta linkage lever and Fillet A, as shown in Figure 3-7. Refer to Figure 3-7 and Figure 3-8.
- 1 If there is interference at Fillet A, make a chamfer in the beta linkage lever to clear Fillet A, as shown in Figure 3-7. The maximum radius in Fillet A as manufactured is 0.015 inch (0.38 mm).

CAUTION: FIT THE BLOCK IN THE BETA RING WITH A MINIMUM SIDE CLEARANCE OF 0.001 INCH (0.03 mm). REFER TO FIGURE 3-7.

- (15) Install the carbon block assembly into the beta ring. Refer to Figure 3-8.
- (16) Install, adjust and safety the beta linkage per the airframe manufacturer's instructions.
- (17) If the propeller is equipped with an accessory drive pulley, follow the applicable manufacturer's instructions for installation of the accessory drive pulley hardware.

- (18) If the propeller is equipped with an ice protection system that uses components supplied by Hartzell Propeller Inc., applicable instructions and technical information for the components supplied by Hartzell Propeller Inc. can be found in the following publications available on the Hartzell Propeller Inc. website at www.hartzellprop.com:
- (a) Manual 180 (30-61-80) - Propeller Ice Protection System Manual
 - (b) Manual 181 (30-60-81) - Propeller Ice Protection Component Maintenance Manual
 - (c) Manual 182 (61-12-82) - Propeller Electrical De-ice Boot Removal and Installation Manual
 - (d) Manual 183 (61-12-83) - Propeller Anti-icing Boot Removal and Installation Manual
- (19) Propeller ice protection system components not supplied by Hartzell Propeller Inc. are controlled by the applicable TC or STC holder's Instructions for Continued Airworthiness (ICA).
- (20) Install the propeller spinner dome in accordance with the section "Spinner Dome Installation" in this chapter.

C1. Installing the HC-E4P-3K Propeller on the Aircraft Engine

- (1) Using a beta system puller CST-2987 (Figure 3-6), compress the beta system and pull the beta ring forward to permit access to the propeller mounting flange.

WARNING: MAKE SURE THE SLING IS RATED UP TO 800 LBS (363 KG) TO SUPPORT THE WEIGHT OF THE PROPELLER ASSEMBLY DURING INSTALLATION.

CAUTION 1: WHEN INSTALLING THE PROPELLER ON THE AIRCRAFT, DO NOT DAMAGE THE ICE PROTECTION SYSTEM COMPONENTS, IF APPLICABLE.

CAUTION 2: INSTRUCTIONS AND PROCEDURES IN THIS SECTION MAY INVOLVE PROPELLER CRITICAL PARTS. REFER TO THE INTRODUCTION CHAPTER OF THIS MANUAL FOR INFORMATION ABOUT PROPELLER CRITICAL PARTS. REFER TO THE ILLUSTRATED PARTS LIST CHAPTER OF THE APPLICABLE OVERHAUL MANUAL(S) FOR THE IDENTIFICATION OF SPECIFIC PROPELLER CRITICAL PARTS.

- (2) With a suitable crane hoist and sling, carefully move the propeller assembly to the aircraft engine mounting flange.

CAUTION: IF THE PROPELLER IS REMOVED BETWEEN OVERHAUL INTERVALS, A TORQUE CHECK OF THE MOUNTING STUDS MUST BE PERFORMED.

- (3) Using Quick Dry Stoddard Solvent or MEK, clean the engine flange and the propeller flange.
- (4) Install the specified O-ring on the engine flange. Refer to Table 3-1.

(5) Put the propeller onto the engine flange.

CAUTION 1: NEW PROPELLER MOUNTING NUTS MUST BE USED WHEN INITIALLY INSTALLING A NEW OR OVERHAULED PROPELLER.

CAUTION 2: THE SIDE OF THE WASHER WITH THE OD CHAMFER MUST BE AGAINST THE ENGINE FLANGE. REFER TO FIGURE 3-10.

(6) Install self locking mounting nuts with washers onto the propeller mounting bolts with the chamfer on the washer against the engine flange. Refer to Table 3-2 for applicable mounting hardware. Refer to Figure 3-11.

(a) If the propeller is removed between overhaul intervals, mounting nuts and washers may be reused if they are not damaged or corroded.

(7) Using a torque wrench and the specified torque wrench adapter (refer to the Tooling section in this chapter), torque all mounting nuts in the sequences and steps shown in Figure 3-3. Refer to Table 3-2 and Figure 3-4 to determine the proper torque value.

(8) Safety all propeller mounting nuts with 0.032 inch (0.81 mm) minimum diameter stainless steel wire or equivalent aircraft safety cable. (Two nuts per safety.)

(9) Decompress the external beta system and remove the beta system puller.

CAUTION: THE BETA FEEDBACK COLLAR MUST NOT CONTACT ANY ENGINE COMPONENT OR MOUNTING BOLT SAFETY WIRE. THE BETA FEEDBACK MECHANISM COULD BE DAMAGED IF IT CONTACTED ANY STATIC ENGINE COMPONENT WHILE ROTATING.

(10) Examine the beta feedback collar to make sure that it is not in contact with any engine components or mounting bolt safety wire.

(a) If there is contact between the beta feedback collar and any engine components or mounting bolt safety wire, consult qualified personnel at a certified propeller repair station with the appropriate rating.

(11) Install the carbon block into the beta linkage lever, in accordance with the airframe manufacturer's instructions.

(a) If the beta linkage lever and the snap ring are not installed correctly, there may be interference between the beta linkage lever and Fillet A, as shown in Figure 3-7. Refer to Figure 3-7 and Figure 3-8.

1 If there is interference at Fillet A, make a chamfer in the beta linkage lever to clear Fillet A, as shown in Figure 3-7. The maximum radius in Fillet A as manufactured is 0.015 inch (0.38 mm).

CAUTION: FIT THE BLOCK IN THE BETA RING WITH A SIDE CLEARANCE OF 0.001 TO 0.002 INCH (0.03 TO 0.05 mm). REFER TO FIGURE 3-7.

(12) Install the carbon block assembly into the beta ring. Refer to Figure 3-8.

(13) Install, adjust, and safety the beta linkage in accordance with the airframe manufacturer's instructions.

(14) If the propeller is equipped with an accessory drive pulley, follow the applicable manufacturer's instructions for installation of the accessory drive pulley hardware.

- (15) If the propeller is equipped with an ice protection system that uses components supplied by Hartzell Propeller Inc., applicable instructions and technical information for the components supplied by Hartzell Propeller Inc. can be found in the following publications available on the Hartzell Propeller Inc. website at www.hartzellprop.com:
- (a) Hartzell Propeller Inc. Manual 180 (30-61-80) - Propeller Ice Protection System Manual
 - (b) Hartzell Propeller Inc. Manual 181 (30-60-81) - Propeller Ice Protection Component Maintenance Manual
 - (c) Hartzell Propeller Inc. Manual 182 (61-12-82) - Propeller Electrical De-ice Boot Removal and Installation Manual
 - (d) Hartzell Propeller Inc. Manual 183 (61-12-83) - Propeller Anti-icing Boot Removal and Installation Manual
- (16) Propeller ice protection system components not supplied by Hartzell Propeller Inc. are controlled by the applicable TC or STC holder's Instructions for Continued Airworthiness (ICA).
- (17) Install the propeller spinner dome in accordance with the section "Spinner Dome Installation" in this chapter.

(This page is intentionally blank.)

- D. Installing the HC-E4W-3() Propeller on the Aircraft Engine
- (1) Using a beta system puller CST-2987 (Figure 3-6), compress the beta system and pull the beta ring forward to permit access to the propeller mounting flange.

WARNING: MAKE SURE THE SLING IS RATED UP TO 800 LBS (363 KG) TO SUPPORT THE WEIGHT OF THE PROPELLER ASSEMBLY DURING INSTALLATION.

CAUTION 1: WHEN INSTALLING THE PROPELLER ON THE AIRCRAFT, DO NOT DAMAGE THE ICE PROTECTION SYSTEM COMPONENTS, IF APPLICABLE.

CAUTION 2: INSTRUCTIONS AND PROCEDURES IN THIS SECTION MAY INVOLVE PROPELLER CRITICAL PARTS. REFER TO THE INTRODUCTION CHAPTER OF THIS MANUAL FOR INFORMATION ABOUT PROPELLER CRITICAL PARTS. REFER TO THE ILLUSTRATED PARTS LIST CHAPTER OF THE APPLICABLE OVERHAUL MANUAL(S) FOR THE IDENTIFICATION OF SPECIFIC PROPELLER CRITICAL PARTS.

- (2) With a suitable crane hoist and sling, carefully move the propeller assembly to the aircraft engine mounting flange.

CAUTION: IF THE PROPELLER IS REMOVED BETWEEN OVERHAUL INTERVALS, A TORQUE CHECK OF THE MOUNTING STUDS MUST BE PERFORMED.

- (3) Unless this is the first installation of a new, or newly overhauled propeller, perform a torque check of the propeller mounting studs as follows:
- (a) Thread the torque check tool AST-2968-1 onto each propeller mounting stud and torque to 35 ft-lbs (47.6 N•m).

- (b) Visually inspect each stud for evidence of movement.
 - (c) Remove the torque check tool AST-2968-1 while visually inspecting each stud for evidence of movement.
 - (d) If any stud rotates due to either the tightening or removal of the torque check tool, all studs that fail the torque requirement must be replaced. Refer to an appropriately licensed repair facility for stud replacement.
- (4) Using Quick Dry Stoddard Solvent or MEK, clean the engine flange and the propeller flange.
- (5) Install the specified O-ring on the engine flange. Refer to Table 3-1.
- (6) If the C-7620 spacer is attached to the propeller hub with screws, proceed to step 3.D.(8).
- (7) If the C-7620 spacer is not already installed on the propeller hub, perform the following installation procedures:
- (a) If the hub flange does not have two 8-32 threaded holes to attach the spacer, or if two attachment screws were not provided, perform the following steps:
 - 1 Coat the hub-to-spacer O-ring with grease. Refer to Table 3-1.

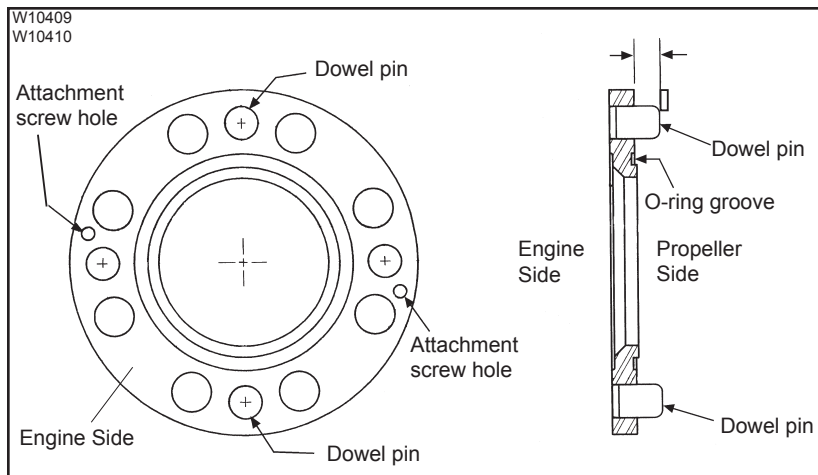

Hub-to-Spacer O-ring Location in the Spacer
Figure 3-9

- 2 Install the hub-to-spacer O-ring in the groove in the spacer that interfaces with the face of the hub flange. Refer to Figure 3-9.
- 3 Align the mounting studs and dowel pin holes in the propeller hub flange with the mounting holes and dowel pins in the spacer.

CAUTION: MAKE SURE THAT THE HUB-TO-SPACER O-RING STAYS IN THE GROOVE IN THE SPACER. IF THE O-RING IS TWISTED OR PINCHED, OIL LEAKAGE WILL RESULT WHEN THE PROPELLER IS OPERATED ON THE AIRCRAFT.

- 4 Slide the spacer onto the mounting studs and against the hub flange.
- 5 If the hub flange has two 8-32 threaded holes and two MS24693-S2 flat-head screws (HPI P/N B-3868-S52) are provided to attach the C-7620 spacer, install the flat-head screws.
- 6 Insert a supplied flat-head screw through each screw hole in the spacer and into the 8-32 threaded holes in the hub flange. Refer to Figure 3-10.

CAUTION: MAKE SURE THAT THE FLAT-HEAD ATTACHMENT SCREWS DO NOT PROTRUDE ABOVE THE ENGINE-SIDE SURFACE OF THE SPACER.

- 7 Tighten the flat-head screw until snug, but do not over-torque.
- 8 If after the flat-head screws are tightened, one or both protrude above the engine side surface of the spacer, check to make sure that the spacer is properly seated against the surface of the hub flange.

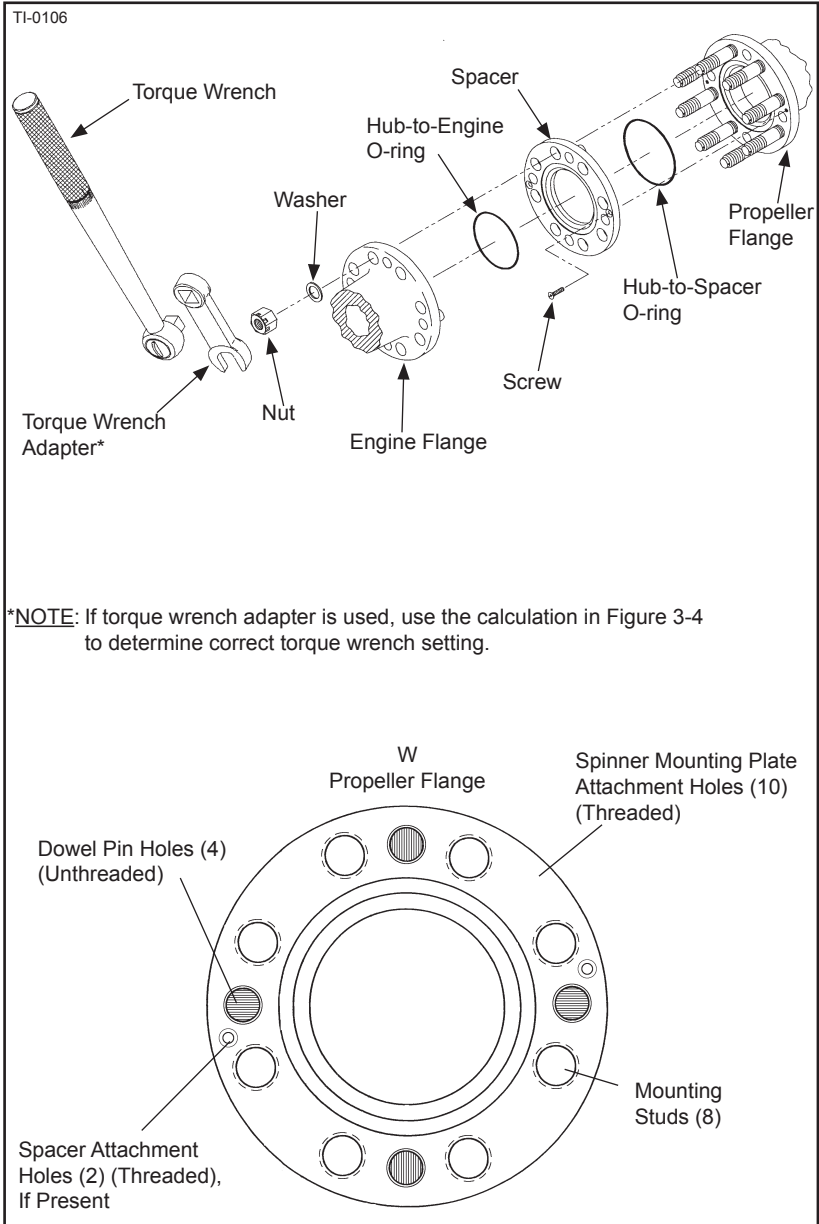

**Installing the HC-E4W-3 () Propeller on Engine Flange
Figure 3-10**

CAUTION 1: MAKE SURE THAT COMPLETE AND TRUE SURFACE CONTACT IS ESTABLISHED BETWEEN THE SPACER AND THE ENGINE FLANGE.

CAUTION 2: IF THE C-7620 SPACER IS NOT ATTACHED TO THE HUB, MAKE SURE THE HUB-TO-SPACER O-RING STAYS IN THE GROOVE IN THE SPACER. IF THE O-RING IS TWISTED OR PINCHED, OIL LEAKAGE WILL RESULT WHEN THE PROPELLER IS OPERATED ON THE AIRCRAFT.

(8) Slide the propeller onto the engine flange.

CAUTION 1: NEW PROPELLER MOUNTING NUTS MUST BE USED WHEN INITIALLY INSTALLING A NEW OR OVERHAULED PROPELLER.

CAUTION 2: THE SIDE OF THE WASHER WITH THE OD CHAMFER MUST BE AGAINST THE ENGINE FLANGE. REFER TO FIGURE 3-10.

(9) Install self locking mounting nuts with washers onto the propeller mounting studs. Refer to Table 3-2 for applicable mounting hardware. Refer to Figure 3-11.

NOTE: The OD chamfer on the washer is for clearance of the engine flange fillet. Refer to Figure 3-11.

(a) If the propeller is removed between overhaul intervals, mounting nuts and washers may be reused if they are not damaged or corroded.

(10) Using a torque wrench and the specified torque wrench adapter (refer to the Tooling section in this chapter), torque all mounting nuts in the sequences and steps shown in Figure 3-3. Refer to Table 3-2 and Figure 3-4 to determine the proper torque value.

(11) Safety all propeller mounting studs with 0.032 inch (0.81 mm) minimum diameter stainless steel wire or equivalent aircraft safety cable. (Two studs per safety.)

(12) Decompress the external beta system and remove the beta system puller.

CAUTION: THE BETA FEEDBACK COLLAR MUST NOT CONTACT ANY ENGINE COMPONENT OR MOUNTING BOLT SAFETY WIRE. THE BETA FEEDBACK MECHANISM COULD BE DAMAGED IF IT CONTACTED ANY STATIC ENGINE COMPONENT WHILE ROTATING.

- (13) Examine the beta feedback collar to make sure that it is not in contact with any engine components or mounting bolt safety wire.
- (a) If there is contact between the beta feedback collar and any engine components or mounting bolt safety wire, consult qualified personnel at an appropriately licensed propeller service facility.
- (14) Install the carbon block into the beta linkage lever, in accordance with the airframe manufacturer's instructions.
- (a) If the beta linkage lever and the snap ring are not installed correctly, there may be interference between the beta linkage lever and Fillet A, as shown in Figure 3-7. Refer to Figure 3-7 and Figure 3-8.
- 1 If there is interference at Fillet A, make a chamfer in the beta linkage lever to clear Fillet A, as shown in Figure 3-7. The maximum radius in Fillet A as manufactured is 0.015 inch (0.38 mm).

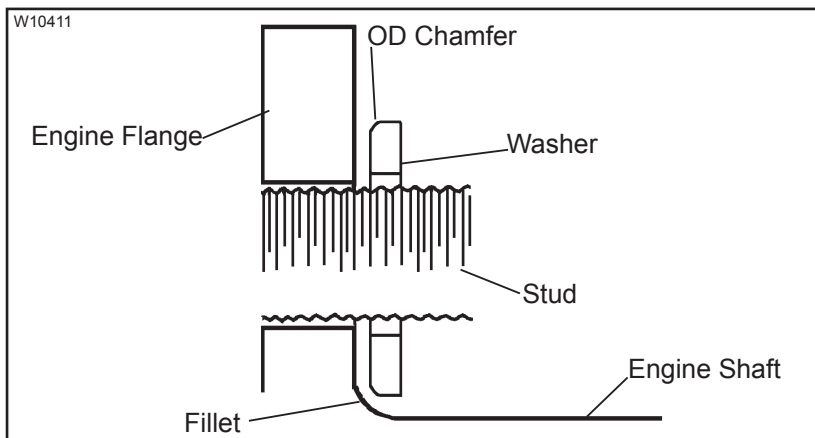

**Installing the Washer on the Mounting Stud
Figure 3-11**

CAUTION: FIT THE BLOCK IN THE BETA RING WITH A SIDE CLEARANCE OF 0.001 TO 0.002 INCH (0.03 TO 0.05 mm). REFER TO FIGURE 3-7.

- (15) Install the carbon block assembly into the beta ring. Refer to Figure 3-8.
- (16) Install, adjust and safety the beta linkage per the airframe manufacturer's instructions.
- (17) If the propeller is equipped with an accessory drive pulley, follow the applicable manufacturer's instructions for installation of the accessory drive pulley hardware.
- (18) If the propeller is equipped with an ice protection system that uses components supplied by Hartzell Propeller Inc., applicable instructions and technical information for the components supplied by Hartzell Propeller Inc. can be found in the following publications available on the Hartzell Propeller Inc. website at www.hartzellprop.com:
 - (a) Manual 180 (30-61-80) - Propeller Ice Protection System Manual
 - (b) Manual 181 (30-60-81) - Propeller Ice Protection Component Maintenance Manual
 - (c) Manual 182 (61-12-82) - Propeller Electrical De-ice Boot Removal and Installation Manual
 - (d) Manual 183 (61-12-83) - Propeller Anti-icing Boot Removal and Installation Manual
- (19) Propeller ice protection system components not supplied by Hartzell Propeller Inc. are controlled by the applicable TC or STC holder's Instructions for Continued Airworthiness (ICA).
- (20) Install the propeller spinner dome in accordance with the section "Spinner Dome Installation" in this chapter.

TI-0103
TI-0102

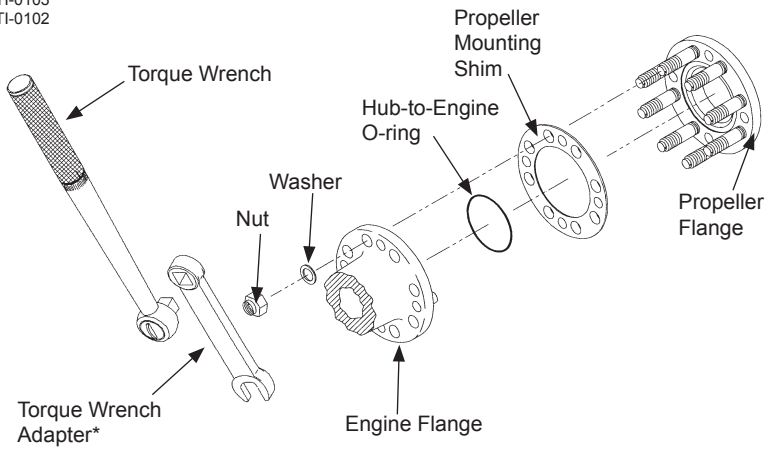

***NOTE:** If torque wrench adapter is used, use the calculation in Figure 3-4 to determine correct torque wrench setting.

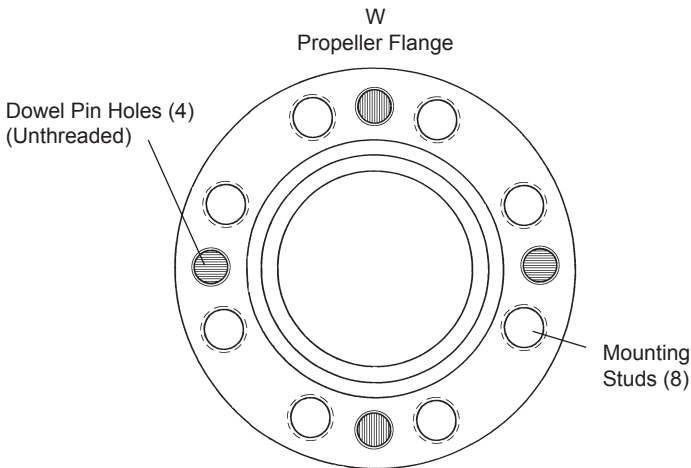

**Installing the HC-E4W-5L Propeller on Engine Flange
Figure 3-12**

E. Installing the HC-E4W-5L Propeller on the Aircraft Engine

WARNING: MAKE SURE THE SLING IS RATED UP TO 800 LBS (363 KG) TO SUPPORT THE WEIGHT OF THE PROPELLER ASSEMBLY DURING INSTALLATION.

CAUTION 1: WHEN INSTALLING THE PROPELLER ON THE AIRCRAFT, DO NOT DAMAGE THE ICE PROTECTION SYSTEM COMPONENTS, IF APPLICABLE.

CAUTION 2: INSTRUCTIONS AND PROCEDURES IN THIS SECTION MAY INVOLVE PROPELLER CRITICAL PARTS. REFER TO THE INTRODUCTION CHAPTER OF THIS MANUAL FOR INFORMATION ABOUT PROPELLER CRITICAL PARTS. REFER TO THE ILLUSTRATED PARTS LIST CHAPTER OF THE APPLICABLE OVERHAUL MANUAL(S) FOR THE IDENTIFICATION OF SPECIFIC PROPELLER CRITICAL PARTS.

- (1) With a suitable crane hoist and sling, carefully move the propeller assembly to the aircraft engine mounting flange.
- (2) Unless this is the first installation of a new, or newly overhauled propeller, perform a torque check of the propeller mounting studs as follows:
 - (a) Thread the torque check tool AST-2968-1 on each propeller mounting stud and torque to 35 ft-lbs (47.6 N•m).
 - (b) Visually inspect each stud for evidence of movement.
 - (c) Remove the torque check tool AST-2968-1 while visually inspecting each stud for evidence of movement.
 - (d) If any stud rotates due to either the tightening or removal of the torque check tool, all studs that fail the torque requirement must be replaced. Refer to an appropriately licensed repair facility for stud replacement.

- (3) Using Quick Dry Stoddard Solvent or MEK, clean the engine flange and the propeller flange.
- (4) Remove the pitch change rod cap, if applicable.
- (5) Install the specified O-ring on the engine flange. Refer to Table 3-1.
- (6) Slide the propeller mounting shim on the mounting studs and against the hub flange.
- (7) Align the mounting and dowel pin holes in the propeller hub flange with the mounting holes and dowel pins in the engine flange.

CAUTION: MAKE SURE THAT COMPLETE AND TRUE SURFACE CONTACT IS ESTABLISHED BETWEEN THE PROPELLER MOUNTING SHIM, THE PROPELLER HUB FLANGE, AND THE ENGINE FLANGE.

- (8) Slide the propeller flange onto the engine flange.

CAUTION 1: NEW PROPELLER MOUNTING NUTS MUST BE USED WHEN INITIALLY INSTALLING A NEW OR OVERHAULED PROPELLER.

CAUTION 2: THE SIDE OF THE WASHER WITH THE OD CHAMFER MUST BE AGAINST THE ENGINE FLANGE. REFER TO FIGURE 3-10.

- (9) Install self locking mounting nuts with washers onto the propeller mounting studs. Refer to Table 3-2 for applicable mounting hardware. Refer to Figure 3-11.

NOTE: The OD chamfer on the washer is for clearance of the engine flange fillet. Refer to Figure 3-11.

- (a) If the propeller is removed between overhaul intervals, mounting nuts and washers may be reused if they are not damaged or corroded.
- (10) Using a torque wrench and the specified torque wrench adapter (refer to the Tooling section in this chapter), torque all mounting nuts in the sequences and steps shown in Figure 3-5. Refer to Table 3-2 and Figure 3-4 to determine the proper torque value.

- (11) Safety all propeller mounting studs with 0.032 inch (0.81 mm) minimum diameter stainless steel wire or equivalent aircraft safety cable. (Two studs per safety.)
- (12) If the propeller is equipped with an ice protection system that uses components supplied by Hartzell Propeller Inc., applicable instructions and technical information for the components supplied by Hartzell Propeller Inc. can be found in the following publications available on the Hartzell Propeller Inc. website at www.hartzellprop.com:
- (a) Manual 180 (30-61-80) - Propeller Ice Protection System Manual
 - (b) Manual 181 (30-60-81) - Propeller Ice Protection Component Maintenance Manual
 - (c) Manual 182 (61-12-82) - Propeller Electrical De-ice Boot Removal and Installation Manual
 - (d) Manual 183 (61-12-83) - Propeller Anti-icing Boot Removal and Installation Manual
- (13) Propeller ice protection system components not supplied by Hartzell Propeller Inc. are controlled by the applicable TC or STC holder's Instructions for Continued Airworthiness (ICA).
- (14) Install the propeller spinner dome in accordance with the section "Spinner Dome Installation" in this chapter.

(This page is intentionally blank.)

- F. Installing the HC-(D,E)4()-5() Propeller on the Aircraft Engine, Except HC-E4W-5L

WARNING: MAKE SURE THE SLING IS RATED UP TO 800 LBS (363 KG) TO SUPPORT THE WEIGHT OF THE PROPELLER ASSEMBLY DURING INSTALLATION.

CAUTION 1: WHEN INSTALLING THE PROPELLER ON THE AIRCRAFT, DO NOT DAMAGE THE ICE PROTECTION SYSTEM COMPONENTS, IF APPLICABLE.

CAUTION 2: INSTRUCTIONS AND PROCEDURES IN THIS SECTION MAY INVOLVE PROPELLER CRITICAL PARTS. REFER TO THE INTRODUCTION CHAPTER OF THIS MANUAL FOR INFORMATION ABOUT PROPELLER CRITICAL PARTS. REFER TO THE ILLUSTRATED PARTS LIST CHAPTER OF THE APPLICABLE OVERHAUL MANUAL(S) FOR THE IDENTIFICATION OF SPECIFIC PROPELLER CRITICAL PARTS.

- (1) With a suitable crane hoist and sling, carefully move the propeller assembly to the aircraft engine mounting flange.
 - (a) Some propellers may require installation of an accessory drive pulley. If installation procedures are not in this manual, refer to the aircraft manufacturer's instructions.
- (2) Using Quick Dry Stoddard Solvent or MEK, clean the engine flange and the propeller flange.
- (3) Remove the pitch change rod cap, if applicable.
- (4) Install the specified O-ring on the engine flange. Refer to Table 3-1.
- (5) Align the mounting and dowel pin holes in the propeller hub flange with the mounting holes and dowel pins in the engine flange.
- (6) Slide the propeller onto the engine flange.

CAUTION 1: MAKE SURE THAT COMPLETE AND TRUE SURFACE CONTACT IS ESTABLISHED BETWEEN THE PROPELLER HUB FLANGE AND THE ENGINE FLANGE.

CAUTION 2: NEW PROPELLER MOUNTING BOLTS MUST BE USED WHEN INITIALLY INSTALLING A NEW OR OVERHAULED PROPELLER.

(7) Apply a MIL-PRF-83483() anti-seize compound to the threaded surfaces of the mounting bolts. Refer to Table 3-1 for the applicable mounting hardware.

- (a) If the propeller is removed between overhaul intervals, mounting bolts and washers may be reused if they are not damaged or corroded.

CAUTION: ID CHAMFER OF WASHER MUST BE FACING TOWARD THE BOLT HEAD. WASHERS WITHOUT CHAMFER MUST BE INSTALLED WITH ROLLED EDGES TOWARD THE BOLT HEAD. (REFER TO FIGURE 3-3).

(8) Install the mounting bolts with washers through the engine flange and into the propeller hub flange. Refer to Figure 3-2.

(9) Using a torque wrench and a torque wrench adapter Hartzell Propeller Inc. P/N AST-2877, torque all mounting bolts in sequences and steps shown in Figure 3-5. Refer to Table 3-2 and Figure 3-4 to determine the proper torque value.

(10) Safety all mounting bolts with 0.032 inch (0.81 mm) minimum diameter stainless steel wire or equivalent aircraft safety cable. (Two bolts per safety.)

(11) Install the beta tube per airframe and/or engine manufacturer's instructions.

- (a) Follow the airframe manufacturer's instructions for adjusting the beta tube to obtain the correct low pitch (flight idle blade angle).
- (b) Refer to the Aircraft Type Certificate Data Sheet for the low pitch blade angle setting.

- (12) If the propeller is equipped with an accessory drive pulley, follow the applicable manufacturer's instructions for installation of the accessory drive pulley hardware.
- (13) If the propeller is equipped with an ice protection system that uses components supplied by Hartzell Propeller Inc., applicable instructions and technical information for the components supplied by Hartzell Propeller Inc. can be found in the following publications available on the Hartzell Propeller Inc. website at www.hartzellprop.com:
 - (a) Manual 180 (30-61-80) - Propeller Ice Protection System Manual
 - (b) Manual 181 (30-60-81) - Propeller Ice Protection Component Maintenance Manual
 - (c) Manual 182 (61-12-82) - Propeller Electrical De-ice Boot Removal and Installation Manual
 - (d) Manual 183 (61-12-83) - Propeller Anti-icing Boot Removal and Installation Manual
- (14) Propeller ice protection system components not supplied by Hartzell Propeller Inc. are controlled by the applicable TC or STC holder's Instructions for Continued Airworthiness (ICA).
- (15) Install the propeller spinner dome in accordance with the section "Spinner Dome Installation" in this chapter.

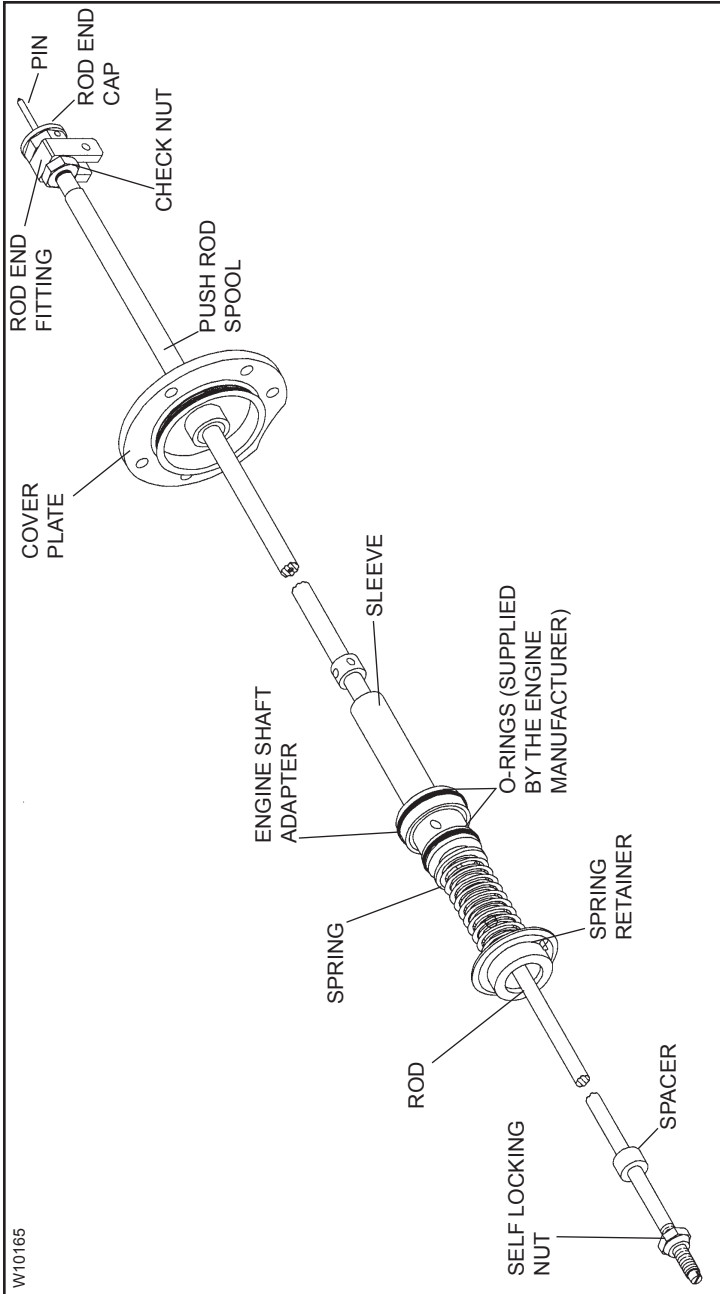

Beta Valve System
Figure 3-13

W10165

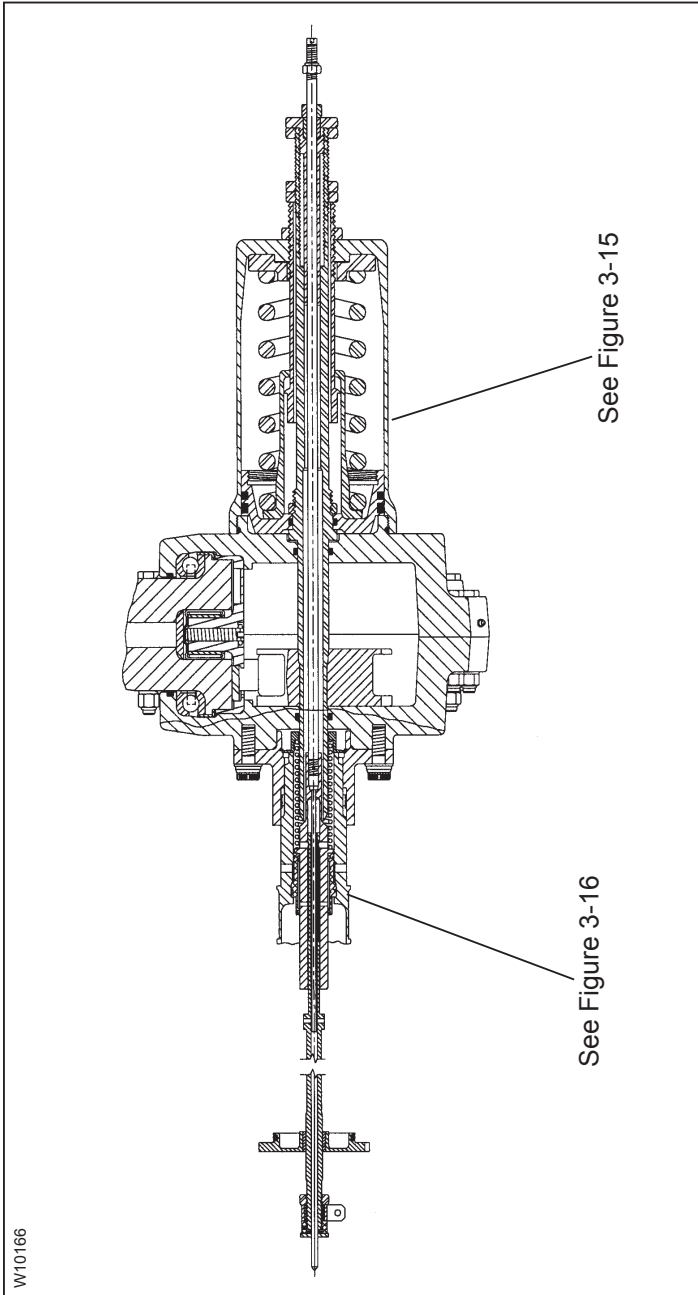

W10166

Beta Valve System in the Propeller
Figure 3-14

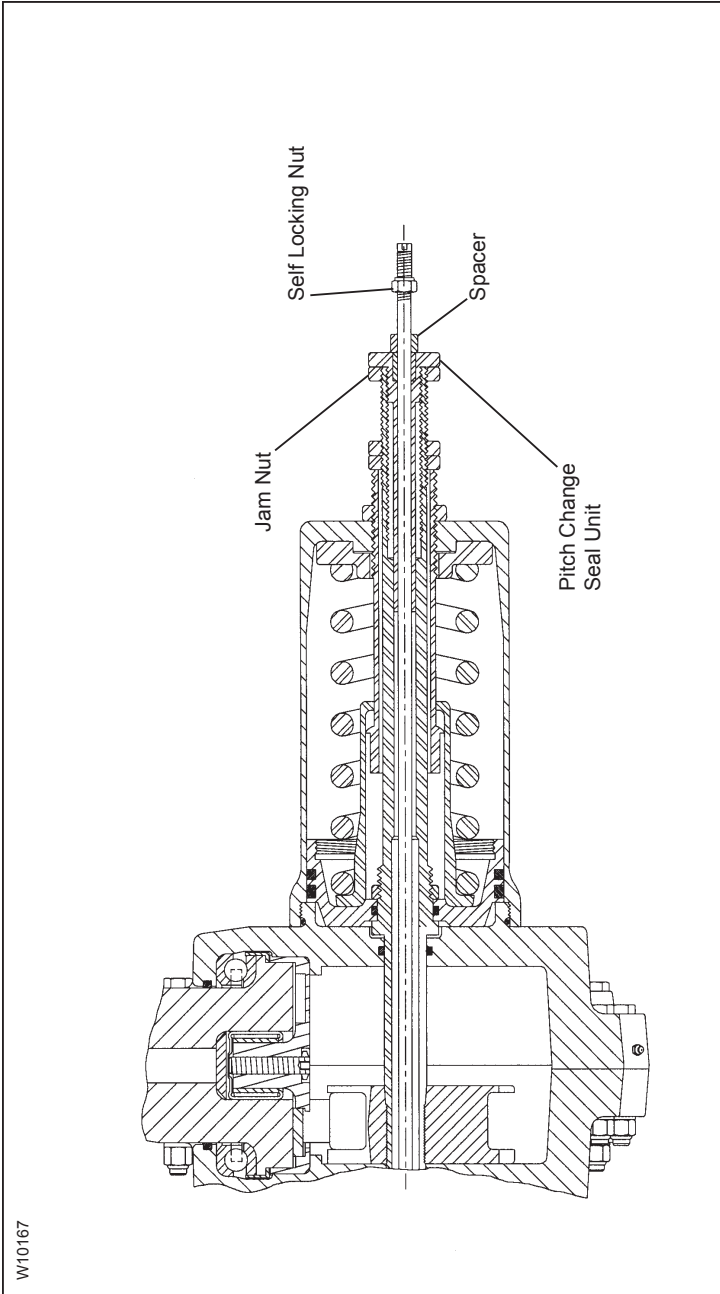

W10167

Front View of the Beta Valve System in the Propeller
Figure 3-15

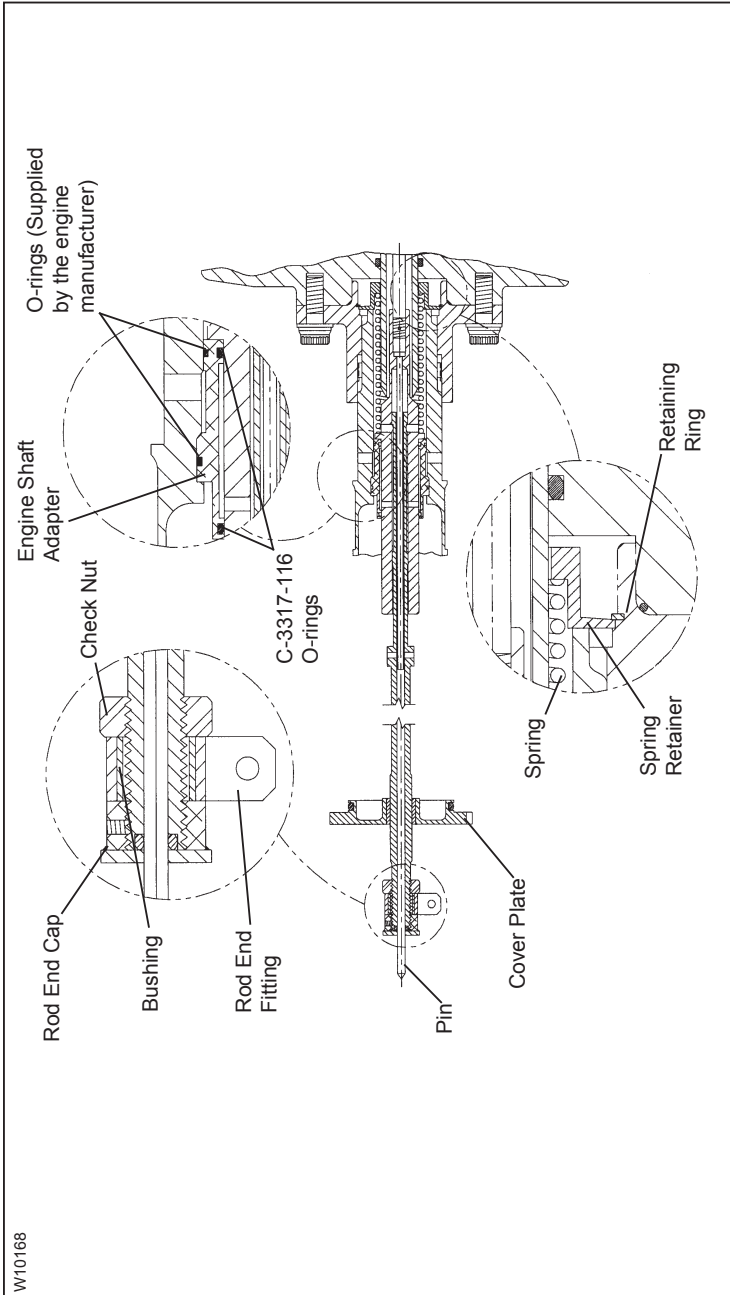

Rear View of the Beta Valve System
in the Propeller
Figure 3-16

W10168

G. Installing the HC-D3F-7() Propeller on the Allison Engine

CAUTION: INSTRUCTIONS AND PROCEDURES IN THIS SECTION MAY INVOLVE PROPELLER CRITICAL PARTS. REFER TO THE INTRODUCTION CHAPTER OF THIS MANUAL FOR INFORMATION ABOUT PROPELLER CRITICAL PARTS. REFER TO THE ILLUSTRATED PARTS LIST CHAPTER OF THE APPLICABLE OVERHAUL MANUAL(S) FOR THE IDENTIFICATION OF SPECIFIC PROPELLER CRITICAL PARTS.

(1) General

- (a) This propeller incorporates a beta valve assembly that is installed inside of the propeller shaft and extends from the rear of the engine to the front of the propeller pitch change rod.
- (b) The beta valve assembly is installed in the engine shaft before the propeller is installed. Refer to Figures 3-13 through 3-16.
- (2) Make sure that the shaft adapter is installed in the engine shaft.
- (3) Install the C-3317-116 O-rings in the two grooves of the shaft adapter. Coat with a light oil (engine oil).
- (4) Remove the cover plate from the rear of the engine case.
- (5) Prepare the beta valve.

NOTE: The beta valve should be preassembled as shown in Figure 3-13 less the pitch change rod, engine shaft adapter, engine supplied o-rings and cover plate when new or from overhaul.

Refer to Figures 3-13 and 3-16.

- (a) If the beta valve is supplied preassembled, remove the self locking nut, spacer, rod end cap, rod end fitting, bushing and check nut.

- (b) If the beta valve is supplied unassembled, assemble as follows:
 - 1 Slide the push rod spool onto the pin and into the sleeve with the threaded end facing away from the sleeve.
 - 2 Slide the spring onto the rod up to and against the shoulder of the sleeve.
 - 3 Install the spring retainer onto the rod with the recessed center section facing toward the two springs.
- (6) Slide the partially assembled beta valve into the engine shaft from the engine shaft end permitting the push rod spool to extend out the rear of the engine. The shoulder of the sleeve should be against the shaft adapter.
- (7) Compress the spring with spring retainer and install the retaining ring that is furnished with the engine to secure the spring retainer.

NOTE: A locator button on the spring retainer will fit into a recess in the engine shaft/flange.
- (8) Install the ID and OD O-rings on the engine cover, per the airframe or engine manufacturer's instructions.
- (9) Install the engine cover on the rear of the engine gear box encircling the beta valve push rod spool, per airframe or engine manufacturer's instructions.

NOTE: Cover plate fasteners are supplied by the engine manufacturer.
- (10) Prepare the propeller for installation.
 - (a) Remove the safety wire from the pitch change seal unit and the jam nut. Refer to Figure 3-15.
 - (b) Remove the pitch change seal unit from the front of the propeller.

WARNING: MAKE SURE THE SLING IS RATED UP TO 800 LBS (363 KG) TO SUPPORT THE WEIGHT OF THE PROPELLER ASSEMBLY DURING INSTALLATION.

CAUTION: WHEN INSTALLING THE PROPELLER ON THE AIRCRAFT, DO NOT DAMAGE THE ICE PROTECTION SYSTEM COMPONENTS, IF APPLICABLE.

- (11) With a suitable crane hoist and sling, carefully move the propeller assembly to the aircraft engine mounting flange.
- (12) Using Quick Dry Stoddard Solvent or MEK, clean the engine flange and the propeller flange.
 - (a) Follow the manufacturer's instructions manual for installation of the spinner bulkhead.
- (13) Remove the pitch change rod cap, if applicable.
- (14) Install the specified O-ring into the groove of the hub flange bore. Refer to Table 3-1.

CAUTION: DO NOT PERMIT THE PROPELLER ASSEMBLY TO HIT OR REST ON THE BETA FEEDBACK ROD. THIS COULD BEND OR OTHERWISE DAMAGE THE FEEDBACK ROD.

- (15) Slide the propeller over the beta valve assembly.
- (16) Align the mounting holes in the propeller hub flange with the mounting holes in the engine flange.

CAUTION: MAKE SURE THAT COMPLETE AND TRUE SURFACE CONTACT IS ESTABLISHED BETWEEN THE PROPELLER HUB FLANGE AND THE ENGINE FLANGE.

- (17) Slide the propeller hub flange onto the engine flange.

CAUTION 1: ID CHAMFER OF THE WASHER MUST BE FACING TOWARD THE BOLT HEAD. WASHERS WITHOUT CHAMFER MUST BE INSTALLED WITH ROLLED EDGES TOWARD THE BOLT HEAD (FIGURE 3-3).

CAUTION 2: NEW PROPELLER MOUNTING BOLTS MUST BE USED WHEN INITIALLY INSTALLING A NEW OR OVERHAULED PROPELLER.

- (18) Install the propeller mounting bolts and washers through the engine flange and into the propeller hub flange. Refer to Table 3-1 for the applicable mounting hardware.
- (a) If the propeller is removed between overhaul intervals, mounting bolts and washers may be reused if they are not damaged or corroded.
- (19) Using a torque wrench and a torque wrench adapter, Hartzell Propeller Inc. P/N AST-2917, torque all the mounting bolts in the sequences and steps shown in Figure 3-5. Refer to Table 3-2 and Figure 3-4 to determine the proper torque value the torque.
- (20) Safety all mounting bolts with 0.032 inch (0.81 mm) minimum diameter stainless steel wire. (Two bolts per safety.)
- (21) Reinstall the pitch change seal unit to the front of the propeller tight against the jam nut.
- (22) Safety the pitch change seal unit and jam nut with 0.032 inch (0.81 mm) minimum diameter stainless steel wire.

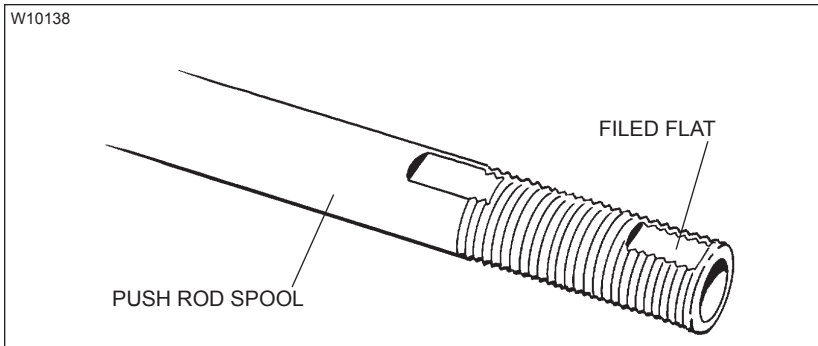

**Filed Rod for Set Screw
Figure 3-17**

CAUTION: THE ROD END CAP MUST BOTTOM ON THE PUSH ROD SPOOL WHEN INSTALLED.

(23) Install the rod end cap onto the threaded end of the push rod spool.

NOTE: Do not tighten the set screw in the rod end cap.

(a) Mark the location of the set screw on the rod and then remove the end cap unit.

(b) File a flat, tangent to the rod, no deeper than the depth of the threads at the marked location of the set screw. Refer to Figure 3-17.

(24) Install the check nut onto the threaded end of the push rod spool.

(25) Install the bushing onto the threaded end of the push rod spool.

(26) Install the rod end fitting onto the threaded end of the push rod spool.

(27) Install the C-3317-006 O-ring in the cavity at the rear end of the push rod spool.

(28) Install the rod end cap onto the threaded end of the push rod spool.

(a) Make sure the rod end cap is bottomed on the end of the push rod spool.

(b) Apply Loctite 272 to the set screw threads.

(c) Tighten the set screw.

(29) Apply Loctite 272 to the push rod threads where the check nut will be located on the push rod spool next to the bushing.

(30) Tighten the check nut against the bushing to torque indicated in Table 3-2.

(31) Attach engine mounted beta system control hardware to the rod end fitting and adjust per airframe or engine manufacturer's instructions.

(32) Install the beta light switch against the pin per airframe manufacturer's instructions.

- (33) Install the spacer and self-locking nut onto the front of the rod that protrudes through the front of the pitch change rod and cylinder.
- (a) Follow the airframe manufacturer's instructions for making pitch control adjustments.
- (34) If the propeller is equipped with an ice protection system that uses components supplied by Hartzell Propeller Inc., applicable instructions and technical information for the components supplied by Hartzell Propeller Inc. can be found in the following publications available on the Hartzell Propeller Inc. website at www.hartzellprop.com:
- (a) Manual 180 (30-61-80) - Propeller Ice Protection System Manual
- (b) Manual 181 (30-60-81) - Propeller Ice Protection Component Maintenance Manual
- (c) Manual 182 (61-12-82) - Propeller Electrical De-ice Boot Removal and Installation Manual
- (d) Manual 183 (61-12-83) - Propeller Anti-icing Boot Removal and Installation Manual
- (35) Propeller ice protection system components not supplied by Hartzell Propeller Inc. are controlled by the applicable TC or STC holder's Instructions for Continued Airworthiness (ICA). Hartzell Propeller ice protection system components not supplied by Hartzell Propeller Inc. are controlled by the applicable TC or STC holder's Instructions for Continued Airworthiness (ICA).
- (36) Install the propeller spinner dome in accordance with the section "Spinner Dome Installation" in this chapter.

BPS816

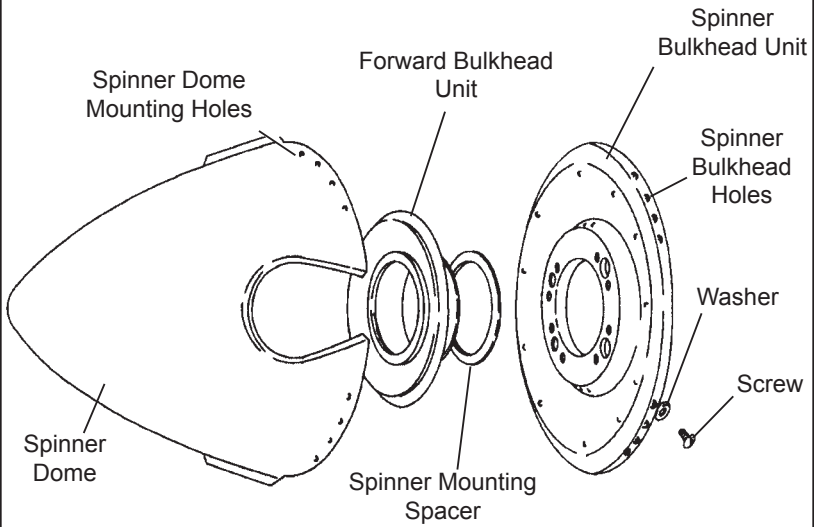

**Spinner Assembly for HC-(D,E)4()-(2,3,5)() and
HC-E5N-3() with D-5505-1() Spinner Assembly
Figure 3-18**

W10150
APS0160A
APS6162

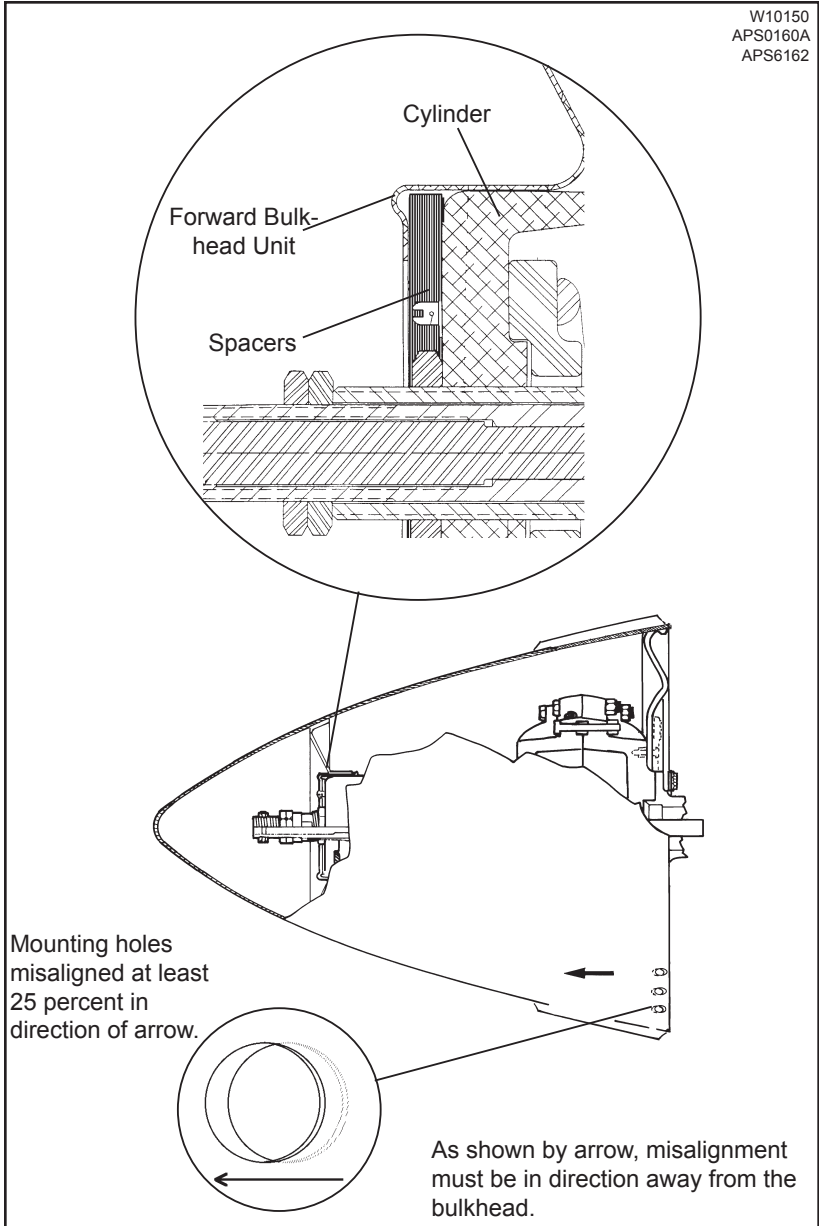

Spinner Reassembly Procedures
Figure 3-19

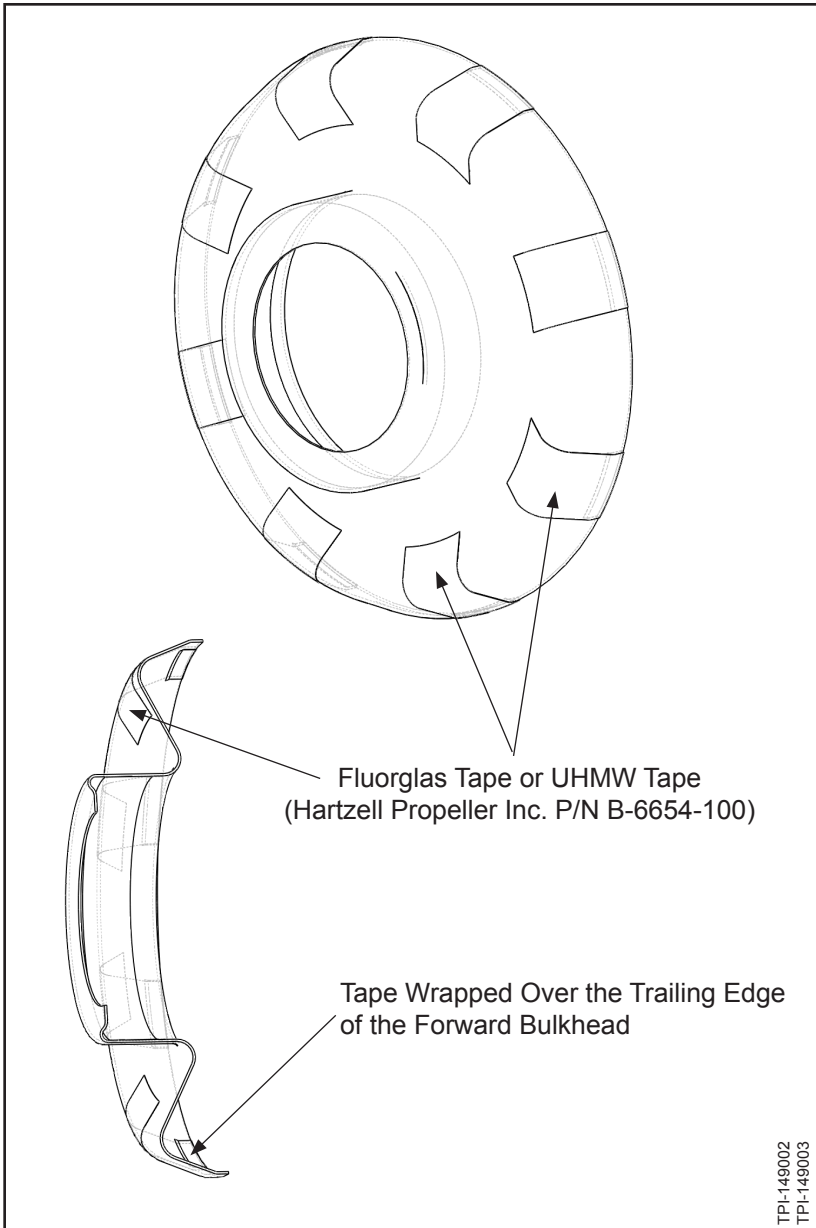

Optional Tape on the Spinner Forward Bulkhead
Figure 3-19.1

4. Spinner Dome Installation

CAUTION 1: TO PREVENT DAMAGE TO THE BLADE AND BLADE PAINT, WRAP THE BLADE SHANKS IN SEVERAL LAYERS OF MASKING OR DUCT TAPE BEFORE INSTALLING THE SPINNER DOME. REMOVE THE TAPE AFTER THE SPINNER IS INSTALLED.

CAUTION 2: SPINNER DOME WILL WOBBLE IF NOT ALIGNED PROPERLY. THIS MAY AFFECT DYNAMIC BALANCE OF PROPELLER.

A. General

(1) The following instructions relate to Hartzell Propeller Inc. spinners only. In some cases, the airframe manufacturer produced the spinner assembly. Refer to the airframe manufacturer's manual for spinner installation instructions.

B. Propeller Models HC-(D,E)4()-(2,3,5)(), HC-E5N-3(), and HC-D3F-7H That Use a One-piece Spinner Dome and Forward Bulkhead

(1) The spinner dome is supported by a forward bulkhead unit that encircles the propeller cylinder. Refer to Figure 3-19.

(a) If the forward bulkhead unit does not fit snugly on the cylinder, the cylinder may need to be wrapped with one or more layers of fluoroglas or UHMW tape (Hartzell Propeller Inc. P/N B-6654-100).

1 Apply a layer of tape, check, and repeat until the forward bulkhead unit fits snugly on the cylinder.

(b) The forward bulkhead unit is positioned away from the cylinder with spacers to cause the spinner dome mounting holes to stop short of full alignment with the bulkhead holes by 25 percent of the spinner dome mounting hole diameter.

(c) Positioning of the spinner dome mounting holes and forward bulkhead unit is accomplished by installing or removing spacers that are between the cylinder and forward bulkhead.

- (2) Optionally for a spinner dome that has a removable forward bulkhead, apply a layer of fluorglas tape or UHMW tape (Hartzell Propeller Inc. P/N B-6654-100) on the outboard flange of the forward bulkhead to prevent contact between the forward bulkhead and the spinner dome.
 - (a) Using acetone, denatured alcohol, or MEK, clean the area where the tape will be applied.
 - (b) Cut eight pieces of tape that are approximately 3 inches (76 mm) long.
 - (c) Apply the pieces of tape in equally spaced locations on the forward bulkhead as shown in Figure 3-19.1.
 - (d) Tape may be wrapped over the trailing edge of the forward bulkhead as necessary.
- (3) Carefully slide the spinner dome over the propeller and forward bulkhead to check for proper positioning of the spinner dome mounting holes. Add or remove spacers to obtain the spinner dome mounting hole and spinner bulkhead hole misalignment. Refer to Figure 3-18.
- (4) Push the spinner dome with firm pressure toward the spinner bulkhead unit to make sure that the spinner dome mounting holes will fully align with the spinner bulkhead holes. Remove a minimum quantity of spacers to obtain hole alignment while maintaining preload.

NOTE: Tension induced by hole misalignment improves spinner longevity and reduces vibration induced wear.
- (5) Attach the spinner dome to the spinner bulkhead with the supplied screws and washers.

(This page is intentionally blank.)

W10151

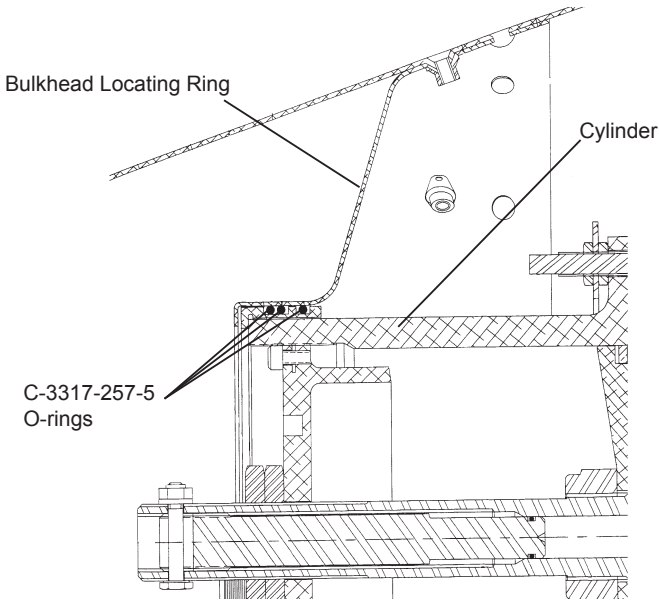

NOTE: This figure shows a cylinder bulkhead locating ring that has one narrow O-ring groove and one wide O-ring groove.

**D-5527-1() Spinner Assembly
Figure 3-20**

C. Propeller Models HC-E5N-3() with D-5527-1() Spinner Assembly

- (1) Install the C-3317-257-5 O-rings into the OD grooves of the bulkhead locating ring that encircles the propeller cylinder. Refer to Figure 3-20.

NOTE: The bulkhead locating ring is bonded to the outboard end of the cylinder OD.

- (a) For a cylinder bulkhead locating ring that has one narrow O-ring groove and one wide O-ring groove:

- 1 Install two O-rings in the wide OD groove.
- 2 Install one O-ring in the narrow OD groove.

- (b) For a cylinder bulkhead locating ring that has two narrow O-ring grooves:

- 1 Install an O-ring in each of the narrow OD grooves.

- (2) Carefully slide the spinner dome over the propeller and cylinder. Align the spinner dome mounting holes with the spinner bulkhead holes.

- (a) Slide the forward bulkhead unit, that is attached to the ID of the spinner dome, over the O-rings installed on the cylinder mounted metal ring.

- (3) Attach the spinner dome to the spinner bulkhead with the supplied screws and washers.

D. Propeller Model HC-D3F-7 Installed on Goodyear Airship GZ-22

- (1) Carefully slide the spinner bulkhead over the propeller and cylinder. Align the spinner dome mounting holes with the spinner bulkhead holes.

- (2) Attach the spinner dome to the spinner bulkhead with the supplied screws and washers.

5. Post-Installation Checks

- A. Refer to the airframe manufacturer's instructions for post-installation checks.
- B. Perform a Maximum RPM (Static) Hydraulic Low Pitch Stop Check as outlined in the Testing and Troubleshooting chapter of this manual.

6. Spinner Dome Removal

CAUTION: TO PREVENT DAMAGING THE BLADE AND BLADE PAINT, WRAP THE BLADE SHANKS IN SEVERAL LAYERS OF MASKING OR DUCT TAPE BEFORE REMOVING THE SPINNER DOME.

- A. Remove the screws and washers that secure the spinner dome to the spinner bulkhead.
- B. Remove the spinner dome.
 - (1) When the spinner dome is removed from the HC-E5N-3() propeller model with the D-5527-1() spinner assembly check the three C-3317-257-5 O-rings in the metal ring encircling the propeller cylinder.
 - (2) Replace the O-rings if they are damaged or worn.

7. Propeller Assembly Removal**A. Removal of HC-(D,E)4()-2() Propellers**

WARNING: FOR SAFETY REASONS, PUT THE PROPELLER IN THE FEATHER POSITION BEFORE IT IS REMOVED FROM THE AIRCRAFT.

CAUTION: INSTRUCTIONS AND PROCEDURES IN THIS SECTION MAY INVOLVE PROPELLER CRITICAL PARTS. REFER TO THE INTRODUCTION CHAPTER OF THIS MANUAL FOR INFORMATION ABOUT PROPELLER CRITICAL PARTS. REFER TO THE ILLUSTRATED PARTS LIST CHAPTER OF THE APPLICABLE OVERHAUL MANUAL(S) FOR THE IDENTIFICATION OF SPECIFIC PROPELLER CRITICAL PARTS.

- (1) Remove the spinner dome in accordance with the section "Spinner Dome Removal" in this chapter.
- (2) If the propeller is equipped with an ice protection system that uses components supplied by Hartzell Propeller Inc., applicable instructions and technical information for the components supplied by Hartzell Propeller Inc. can be found in the following publications available on the Hartzell Propeller Inc. website at www.hartzellprop.com:
 - (a) Manual 180 (30-61-80) - Propeller Ice Protection System Manual
 - (b) Manual 181 (30-60-81) - Propeller Ice Protection Component Maintenance Manual
 - (c) Manual 182 (61-12-82) - Propeller Electrical De-ice Boot Removal and Installation Manual
 - (d) Manual 183 (61-12-83) - Propeller Anti-icing Boot Removal and Installation Manual
- (3) Propeller ice protection system components not supplied by Hartzell Propeller Inc. are controlled by the applicable TC or STC holder's Instructions for Continued Airworthiness (ICA).

- (4) Some propellers may require installation of an accessory drive pulley. If installation procedures are not in this manual, refer to the aircraft manufacturer's instructions.
- (5) Cut and remove the safety wire (if installed) on the propeller mounting bolts.

WARNING 1: DURING ENGINE INSTALLATION OR REMOVAL, USING THE PROPELLER TO SUPPORT THE WEIGHT OF THE ENGINE IS NOT AUTHORIZED. UNAPPROVED INSTALLATION AND REMOVAL TECHNIQUES MAY CAUSE DAMAGE TO THE PROPELLER THAT MAY LEAD TO FAILURE AND RESULT IN AN AIRCRAFT ACCIDENT.

WARNING 2: DURING PROPELLER REMOVAL, AIRFRAME MANUFACTURER'S MANUALS AND PROCEDURES MUST BE FOLLOWED BECAUSE THEY MAY CONTAIN ISSUES VITAL TO AIRCRAFT SAFETY THAT ARE NOT CONTAINED IN THIS MANUAL OR THE HARTZELL PROPELLER OVERHAUL MANUALS.

WARNING 3: MAKE SURE THE SLING IS RATED UP TO 800 LBS (363 KG) TO SUPPORT THE WEIGHT OF THE PROPELLER ASSEMBLY DURING REMOVAL.

- (6) Support the propeller assembly with a sling.

NOTE: Supporting the propeller with the sling may be delayed until all but two mounting bolts and washers have been removed to permit rotating the propeller for ease of bolt removal.

- (7) If the propeller will be reinstalled, and it has been dynamically balanced, make an identifying mark on the propeller hub and a matching mark on the engine flange to make sure of correct orientation during reinstallation to prevent dynamic imbalance.

- (8) For propeller models with air conditioning accessories:
removal of air conditioning drive accessories, if installed.
- (a) Remove the accessory mounting bolts and washers.
 - (b) Remove the two-piece air conditioning pulley.
 - (c) Temporarily reattach the spinner bulkhead and pulley containment ring to the hub with two of the accessory mounting bolts.

CAUTION: DISCARD THE PROPELLER MOUNTING BOLTS IF THEY ARE DAMAGED OR CORRODED, OR WHEN THE PROPELLER IS REMOVED FOR OVERHAUL.

- (9) Remove the propeller mounting bolts and washers.
- (a) If the propeller is removed between overhaul intervals, mounting bolts and washers may be reused if they are not damaged or corroded.

CAUTION: USE ADEQUATE PRECAUTIONS TO PROTECT THE PROPELLER ASSEMBLY FROM DAMAGE WHEN IT IS REMOVED FROM THE AIRCRAFT ENGINE AND WHEN IT IS STORED.

- (10) Using the support sling, lift the propeller from the mounting flange.
- (11) Remove and discard the propeller mounting O-ring.
- (12) Install suitable covers on the pitch change rod opening, propeller mounting flange, and engine flange to prevent the introduction of contamination.
- (13) For propeller models with air conditioning accessories:
- (a) Remove the temporary fasteners attaching the spinner bulkhead and pulley containment ring.
 - (b) Remove the spinner bulkhead and pulley containment ring.
- (14) Put the propeller on a suitable cart for transportation.

B. Removal of HC-(D,E)(4,5)(A,N)-3() Propellers

WARNING: FOR SAFETY REASONS, PUT THE PROPELLER IN THE FEATHER POSITION BEFORE IT IS REMOVED FROM THE AIRCRAFT.

CAUTION: INSTRUCTIONS AND PROCEDURES IN THIS SECTION MAY INVOLVE PROPELLER CRITICAL PARTS. REFER TO THE INTRODUCTION CHAPTER OF THIS MANUAL FOR INFORMATION ABOUT PROPELLER CRITICAL PARTS. REFER TO THE ILLUSTRATED PARTS LIST CHAPTER OF THE APPLICABLE OVERHAUL MANUAL(S) FOR THE IDENTIFICATION OF SPECIFIC PROPELLER CRITICAL PARTS.

- (1) Remove the spinner dome in accordance with the section "Spinner Dome Removal" in this chapter.
- (2) If the propeller is equipped with an ice protection system that uses components supplied by Hartzell Propeller Inc., applicable instructions and technical information for the components supplied by Hartzell Propeller Inc. can be found in the following publications available on the Hartzell Propeller Inc. website at www.hartzellprop.com:
 - (a) Manual 180 (30-61-80) - Propeller Ice Protection System Manual
 - (b) Manual 181 (30-60-81) - Propeller Ice Protection Component Maintenance Manual
 - (c) Manual 182 (61-12-82) - Propeller Electrical De-ice Boot Removal and Installation Manual
 - (d) Manual 183 (61-12-83) - Propeller Anti-icing Boot Removal and Installation Manual
- (3) Propeller ice protection system components not supplied by Hartzell Propeller Inc. are controlled by the applicable TC or STC holder's Instructions for Continued Airworthiness (ICA).

- (4) Some propellers may require installation of an accessory drive pulley. If installation procedures are not in this manual, refer to the aircraft manufacturer's instructions.
- (5) Disconnect the engine beta linkage and the carbon block assembly from the beta ring per airframe manufacturer's instructions. Refer to Figure 3-8.
- (6) Remove the snap ring that retains the carbon block assembly to the beta linkage.
- (7) Remove the carbon block assembly. Refer to Figure 3-7.
- (8) Using the beta system puller, CST-2987, compress the beta system and pull the beta ring forward to expose the propeller mounting bolts and washers. Refer to Figure 3-6.

WARNING 1: DURING ENGINE INSTALLATION OR REMOVAL, USING THE PROPELLER TO SUPPORT THE WEIGHT OF THE ENGINE IS NOT AUTHORIZED. UNAPPROVED INSTALLATION AND REMOVAL TECHNIQUES MAY CAUSE DAMAGE TO THE PROPELLER THAT MAY LEAD TO FAILURE AND RESULT IN AN AIRCRAFT ACCIDENT.

WARNING 2: DURING PROPELLER REMOVAL, AIRFRAME MANUFACTURER'S MANUALS AND PROCEDURES MUST BE FOLLOWED BECAUSE THEY MAY CONTAIN ISSUES VITAL TO AIRCRAFT SAFETY THAT ARE NOT CONTAINED IN THIS MANUAL OR THE HARTZELL PROPELLER OVERHAUL MANUALS.

WARNING 3: MAKE SURE THE SLING IS RATED UP TO 800 LBS (363 KG) TO SUPPORT THE WEIGHT OF THE PROPELLER ASSEMBLY DURING REMOVAL.

- (9) Support the propeller assembly with a sling.
- (10) Cut and remove the safety wire (if installed) on the propeller mounting bolts.

CAUTION: DISCARD THE PROPELLER MOUNTING BOLTS IF THEY ARE DAMAGED OR CORRODED, OR WHEN THE PROPELLER IS REMOVED FOR OVERHAUL.

(11) Remove the propeller mounting bolts and washers.

- (a) If the propeller is removed between overhaul intervals, mounting bolts and washers may be reused if they are not damaged or corroded.

CAUTION: USE ADEQUATE PRECAUTIONS TO PROTECT THE PROPELLER ASSEMBLY FROM DAMAGE WHEN IT IS REMOVED FROM THE AIRCRAFT ENGINE AND WHEN IT IS STORED.

(12) Using the support sling, lift the propeller from the mounting flange.

(13) Remove and discard the propeller mounting O-ring.

(14) Install suitable covers on the pitch change rod opening, propeller mounting flange, and engine flange to prevent the introduction of contamination.

(15) Decompress and remove the beta system puller.

(16) Put the propeller on a suitable cart for transportation.

B1. Removal of HC-E4P-3K Propellers

WARNING: FOR SAFETY REASONS, PUT THE PROPELLER IN THE FEATHER POSITION BEFORE IT IS REMOVED FROM THE AIRCRAFT.

CAUTION: INSTRUCTIONS AND PROCEDURES IN THIS SECTION MAY INVOLVE PROPELLER CRITICAL PARTS. REFER TO THE INTRODUCTION CHAPTER OF THIS MANUAL FOR INFORMATION ABOUT PROPELLER CRITICAL PARTS. REFER TO THE ILLUSTRATED PARTS LIST CHAPTER OF THE APPLICABLE OVERHAUL MANUAL(S) FOR THE IDENTIFICATION OF SPECIFIC PROPELLER CRITICAL PARTS.

- (1) Remove the spinner dome in accordance with the section, "Spinner Dome Removal" in this chapter.
- (2) If the propeller is equipped with an ice protection system that uses components supplied by Hartzell Propeller Inc., applicable instructions and technical information for the components supplied by Hartzell Propeller Inc. can be found in the following publications available on the Hartzell Propeller Inc. website at www.hartzellprop.com:
 - (a) Hartzell Propeller Inc. Manual 180 (30-61-80) - Propeller Ice Protection System Manual
 - (b) Hartzell Propeller Inc. Manual 181 (30-60-81) - Propeller Ice Protection Component Maintenance Manual
 - (c) Hartzell Propeller Inc. Manual 182 (61-12-82) - Propeller Electrical De-ice Boot Removal and Installation Manual
 - (d) Hartzell Propeller Inc. Manual 183 (61-12-83) - Propeller Anti-icing Boot Removal and Installation Manual

- (3) Propeller ice protection system components not supplied by Hartzell Propeller Inc. are controlled by the applicable TC or STC holder's Instructions for Continued Airworthiness (ICA).
- (4) Some propellers may require installation of an accessory drive pulley. If installation procedures are not in this manual, refer to the aircraft manufacturer's instructions.
- (5) Disconnect the engine beta linkage and the carbon block assembly from the beta ring in accordance with the airframe manufacturer's instructions. Refer to Figure 3-8.
- (6) Remove the snap ring that retains the carbon block assembly to the beta linkage.
- (7) Remove the carbon block assembly. Refer to Figure 3-7.
- (8) Using the beta system puller, CST-2987, compress the beta system and pull the beta ring forward to expose the propeller mounting nuts and washers. Refer to Figure 3-6.

WARNING 1: DURING ENGINE INSTALLATION OR REMOVAL, USING THE PROPELLER TO SUPPORT THE WEIGHT OF THE ENGINE IS NOT AUTHORIZED. UNAPPROVED INSTALLATION AND REMOVAL TECHNIQUES MAY CAUSE DAMAGE TO THE PROPELLER THAT MAY LEAD TO FAILURE AND RESULT IN AN AIRCRAFT ACCIDENT.

WARNING 2: DURING PROPELLER REMOVAL, AIRFRAME MANUFACTURER'S MANUALS AND PROCEDURES MUST BE FOLLOWED BECAUSE THEY MAY CONTAIN ISSUES VITAL TO AIRCRAFT SAFETY THAT ARE NOT CONTAINED IN THIS MANUAL OR THE HARTZELL PROPELLER INC. OVERHAUL MANUALS.

WARNING 3: MAKE SURE THE SLING IS RATED UP TO 800 LBS (363 KG) TO SUPPORT THE WEIGHT OF THE PROPELLER ASSEMBLY DURING REMOVAL.

(9) Support the propeller assembly with a sling.

(10) Cut and remove the safety wire (if installed) on the propeller mounting nuts.

CAUTION: DISCARD THE PROPELLER MOUNTING NUTS IF THEY ARE DAMAGED OR CORRODED, OR WHEN THE PROPELLER IS REMOVED FOR OVERHAUL.

(11) Remove the propeller mounting nuts and washers.

(a) If the propeller is removed between overhaul intervals, mounting nuts and washers may be reused if they are not damaged or corroded.

CAUTION: USE ADEQUATE PRECAUTIONS TO PROTECT THE PROPELLER ASSEMBLY FROM DAMAGE WHEN IT IS REMOVED FROM THE AIRCRAFT ENGINE AND WHEN IT IS STORED.

- (12) Using the support sling, lift the propeller from the mounting flange.
- (13) Remove and discard the propeller mounting O-ring.
- (14) Install suitable covers on the pitch change rod opening, propeller mounting flange, and engine flange to prevent the introduction of contamination.
- (15) Decompress and remove the beta system puller.
- (16) Put the propeller on a suitable cart for transportation.

C. Removal of HC-E4W-3() Propellers

CAUTION: INSTRUCTIONS AND PROCEDURES IN THIS SECTION MAY INVOLVE PROPELLER CRITICAL PARTS. REFER TO THE INTRODUCTION CHAPTER OF THIS MANUAL FOR INFORMATION ABOUT PROPELLER CRITICAL PARTS. REFER TO THE ILLUSTRATED PARTS LIST CHAPTER OF THE APPLICABLE OVERHAUL MANUAL(S) FOR THE IDENTIFICATION OF SPECIFIC PROPELLER CRITICAL PARTS.

- (1) Remove the spinner dome in accordance with the section "Spinner Dome Removal" in this chapter.
- (2) If the propeller is equipped with an ice protection system that uses components supplied by Hartzell Propeller Inc., applicable instructions and technical information for the components supplied by Hartzell Propeller Inc. can be found in the following publications available on the Hartzell Propeller Inc. website at www.hartzellprop.com:
 - (a) Manual 180 (30-61-80) - Propeller Ice Protection System Manual
 - (b) Manual 181 (30-60-81) - Propeller Ice Protection Component Maintenance Manual
 - (c) Manual 182 (61-12-82) - Propeller Electrical De-ice Boot Removal and Installation Manual
 - (d) Manual 183 (61-12-83) - Propeller Anti-icing Boot Removal and Installation Manual
- (3) Propeller ice protection system components not supplied by Hartzell Propeller Inc. are controlled by the applicable TC or STC holder's Instructions for Continued Airworthiness (ICA).
- (4) Disconnect the engine beta linkage and carbon block assembly from the beta ring per the airframe manufacturer's instructions. Refer to Figure 3-7.

(a) If the carbon block must be removed, perform the following procedures:

- 1 Remove the snap ring that retains the carbon block assembly to the beta linkage.
- 2 Remove the carbon block assembly.

CAUTION: MAKE SURE THAT THE BETA LINKAGE IS DISCONNECTED BEFORE COMPRESSING THE BETA SYSTEM.

(5) Using the beta system puller, Hartzell Propeller Inc. P/N CST-2987, compress the beta system and pull the beta ring forward to expose the propeller mounting nuts and washers. Refer to Figure 3-5.

WARNING 1: DURING ENGINE INSTALLATION OR REMOVAL, USING THE PROPELLER TO SUPPORT THE WEIGHT OF THE ENGINE IS NOT AUTHORIZED. UNAPPROVED INSTALLATION AND REMOVAL TECHNIQUES MAY CAUSE DAMAGE TO THE PROPELLER THAT MAY LEAD TO FAILURE AND RESULT IN AN AIRCRAFT ACCIDENT.

WARNING 2: DURING PROPELLER REMOVAL, AIRFRAME MANUFACTURER'S MANUALS AND PROCEDURES MUST BE FOLLOWED BECAUSE THEY MAY CONTAIN ISSUES VITAL TO AIRCRAFT SAFETY THAT ARE NOT CONTAINED IN THIS MANUAL OR THE HARTZELL PROPELLER OVERHAUL MANUALS.

WARNING 3: MAKE SURE THE SLING IS RATED UP TO 800 LBS (363 KG) TO SUPPORT THE WEIGHT OF THE PROPELLER ASSEMBLY DURING REMOVAL.

(6) Cut and remove the safety wire on the propeller mounting studs.

- (7) Support the propeller assembly with a sling.

NOTE: Supporting the propeller with the sling may be delayed until all but two mounting nuts and washers have been removed to permit rotating the propeller for ease of nut removal.

- (8) If the propeller will be reinstalled, and it has been dynamically balanced, make an identifying mark on the propeller hub and a matching mark on the engine flange to ensure proper orientation during reinstallation to prevent dynamic imbalance.

CAUTION: DISCARD THE PROPELLER MOUNTING NUTS AND/OR WASHERS IF THEY ARE DAMAGED OR CORRODED, OR WHEN THE PROPELLER IS REMOVED FOR OVERHAUL.

- (9) Remove the propeller mounting nuts and washers.

(a) If the propeller is removed between overhaul intervals, mounting nuts and washers may be reused if they are not damaged or corroded.

CAUTION: USE ADEQUATE PRECAUTIONS TO PROTECT THE PROPELLER ASSEMBLY FROM DAMAGE WHEN IT IS REMOVED FROM THE AIRCRAFT ENGINE AND WHEN IT IS STORED.

- (10) Using the support sling, lift the propeller from the mounting flange.

- (11) Remove and discard the engine flange-to-spacer O-ring.

- (12) If the C-7620 spacer is not attached with flat-head screws, perform the following procedures:

(a) Remove the spacer from the hub.

(b) Remove and discard the hub-to-spacer O-ring.

- (13) If the C-7620 spacer is attached to the hub with flat-head screws, perform the following procedures if the O-ring must be replaced due to oil leakage.

(a) Remove the spacer attachment screws, if applicable.

(b) Remove the C-7620 spacer.

(c) Remove and discard the propeller hub-to-spacer O-ring.

- (14) Decompress and remove the beta system puller.
- (15) Put the propeller on a suitable cart for transportation.

D. Removal of HC-E4W-5L Propellers

WARNING: FOR SAFETY REASONS, PUT THE PROPELLER IN FEATHER POSITION BEFORE IT IS REMOVED FROM THE AIRCRAFT.

CAUTION 1: WHEN REMOVING THE PROPELLER FROM THE AIRCRAFT, DO NOT DAMAGE THE ICE PROTECTION SYSTEM COMPONENTS, IF APPLICABLE.

CAUTION 2: INSTRUCTIONS AND PROCEDURES IN THIS SECTION MAY INVOLVE PROPELLER CRITICAL PARTS. REFER TO THE INTRODUCTION CHAPTER OF THIS MANUAL FOR INFORMATION ABOUT PROPELLER CRITICAL PARTS. REFER TO THE ILLUSTRATED PARTS LIST CHAPTER OF THE APPLICABLE OVERHAUL MANUAL(S) FOR THE IDENTIFICATION OF SPECIFIC PROPELLER CRITICAL PARTS.

- (1) Remove the spinner dome in accordance with the section "Spinner Dome Removal" in this chapter.
- (2) If the propeller is equipped with an ice protection system that uses components supplied by Hartzell Propeller Inc., applicable instructions and technical information for the components supplied by Hartzell Propeller Inc. can be found in the following publications available on the Hartzell Propeller Inc. website at www.hartzellprop.com:
 - (a) Manual 180 (30-61-80) - Propeller Ice Protection System Manual
 - (b) Manual 181 (30-60-81) - Propeller Ice Protection Component Maintenance Manual
 - (c) Manual 182 (61-12-82) - Propeller Electrical De-ice Boot Removal and Installation Manual
 - (d) Manual 183 (61-12-83) - Propeller Anti-icing Boot Removal and Installation Manual

- (3) Propeller ice protection system components not supplied by Hartzell Propeller Inc. are controlled by the applicable TC or STC holder's Instructions for Continued Airworthiness (ICA).
- (4) Some propellers may require installation of an accessory drive pulley. If installation procedures are not in this manual, refer to the aircraft manufacturer's instructions.

CAUTION: THE BETA TUBE MUST BE REMOVED BEFORE THE PROPELLER ASSEMBLY IS REMOVED FROM THE AIRCRAFT. REFER TO THE AIRCRAFT MAINTENANCE INSTRUCTION MANUAL.

- (5) Remove beta tube.
- (6) Cut and remove the safety wire (if installed) on the propeller mounting bolts.

WARNING 1: DURING ENGINE INSTALLATION OR REMOVAL, USING THE PROPELLER TO SUPPORT THE WEIGHT OF THE ENGINE IS NOT AUTHORIZED. UNAPPROVED INSTALLATION AND REMOVAL TECHNIQUES MAY CAUSE DAMAGE TO THE PROPELLER THAT MAY LEAD TO FAILURE AND RESULT IN AN AIRCRAFT ACCIDENT.

WARNING 2: DURING PROPELLER REMOVAL, AIRFRAME MANUFACTURER'S MANUALS AND PROCEDURES MUST BE FOLLOWED BECAUSE THEY MAY CONTAIN ISSUES VITAL TO AIRCRAFT SAFETY THAT ARE NOT CONTAINED IN THIS MANUAL OR THE HARTZELL PROPELLER OVERHAUL MANUALS.

WARNING 3: MAKE SURE THE SLING IS RATED UP TO 800 LBS (363 KG) TO SUPPORT THE WEIGHT OF THE PROPELLER ASSEMBLY DURING REMOVAL.

- (7) Support the propeller assembly with a sling.

NOTE: Supporting the propeller with the sling may be delayed until all but two mounting bolts and washers have been removed to permit rotating the propeller for ease of bolt removal.

- (a) If the propeller will be reinstalled, and it has been dynamically balanced, make an identifying mark on the propeller hub and a matching mark on the engine flange to make sure of proper orientation during reinstallation to prevent dynamic imbalance.

CAUTION: DISCARD THE PROPELLER MOUNTING NUTS AND/OR WASHERS IF THEY ARE DAMAGED OR CORRODED, OR WHEN THE PROPELLER IS REMOVED FOR OVERHAUL.

- (8) Remove the propeller mounting nuts and washers.

- (a) If the propeller is removed between overhaul intervals, mounting nuts and washers may be reused if they are not damaged or corroded.

CAUTION: USE ADEQUATE PRECAUTIONS TO PROTECT THE PROPELLER ASSEMBLY FROM DAMAGE WHEN IT IS REMOVED FROM THE AIRCRAFT ENGINE AND WHEN IT IS STORED.

- (9) Using the support sling, lift the propeller from the mounting flange.

- (10) Remove and discard the propeller mounting O-ring.

- (11) Remove the propeller mounting shim.

- (12) Install suitable covers on the pitch change rod opening, propeller mounting flange, and engine flange to prevent the introduction of contamination.

- (13) Put the propeller on a suitable cart for transportation.

E. Removal of HC-(D,E)4()-5() Propellers, except E4W-5L

WARNING: FOR SAFETY REASONS, PUT THE PROPELLER IN FEATHER POSITION BEFORE IT IS REMOVED FROM THE AIRCRAFT.

CAUTION: INSTRUCTIONS AND PROCEDURES IN THIS SECTION MAY INVOLVE PROPELLER CRITICAL PARTS. REFER TO THE INTRODUCTION CHAPTER OF THIS MANUAL FOR INFORMATION ABOUT PROPELLER CRITICAL PARTS. REFER TO THE ILLUSTRATED PARTS LIST CHAPTER OF THE APPLICABLE OVERHAUL MANUAL(S) FOR THE IDENTIFICATION OF SPECIFIC PROPELLER CRITICAL PARTS.

- (1) Remove the spinner dome in accordance with the section "Spinner Dome Removal" in this chapter.
- (2) If the propeller is equipped with an ice protection system that uses components supplied by Hartzell Propeller Inc., applicable instructions and technical information for the components supplied by Hartzell Propeller Inc. can be found in the following publications available on the Hartzell Propeller Inc. website at www.hartzellprop.com:
 - (a) Manual 180 (30-61-80) - Propeller Ice Protection System Manual
 - (b) Manual 181 (30-60-81) - Propeller Ice Protection Component Maintenance Manual
 - (c) Manual 182 (61-12-82) - Propeller Electrical De-ice Boot Removal and Installation Manual
 - (d) Manual 183 (61-12-83) - Propeller Anti-icing Boot Removal and Installation Manual
- (3) Propeller ice protection system components not supplied by Hartzell Propeller Inc. are controlled by the applicable TC or STC holder's Instructions for Continued Airworthiness (ICA).

- (4) Some propellers may require installation of an accessory drive pulley. If installation procedures are not in this manual, refer to the aircraft manufacturer's instructions.

CAUTION: THE BETA TUBE MUST BE REMOVED BEFORE THE PROPELLER ASSEMBLY IS REMOVED FROM THE AIRCRAFT. REFER TO THE AIRCRAFT MAINTENANCE INSTRUCTION MANUAL.

- (5) Remove beta tube.
(6) Cut and remove the safety wire (if installed) on the propeller mounting bolts.

WARNING 1: DURING ENGINE INSTALLATION OR REMOVAL, USING THE PROPELLER TO SUPPORT THE WEIGHT OF THE ENGINE IS NOT AUTHORIZED. UNAPPROVED INSTALLATION AND REMOVAL TECHNIQUES MAY CAUSE DAMAGE TO THE PROPELLER THAT MAY LEAD TO FAILURE AND RESULT IN AN AIRCRAFT ACCIDENT.

WARNING 2: DURING PROPELLER REMOVAL, AIRFRAME MANUFACTURER'S MANUALS AND PROCEDURES MUST BE FOLLOWED BECAUSE THEY MAY CONTAIN ISSUES VITAL TO AIRCRAFT SAFETY THAT ARE NOT CONTAINED IN THIS MANUAL OR THE HARTZELL PROPELLER OVERHAUL MANUALS.

WARNING 3: MAKE SURE THE SLING IS RATED UP TO 800 LBS (363 KG) TO SUPPORT THE WEIGHT OF THE PROPELLER ASSEMBLY DURING REMOVAL.

- (7) Support the propeller assembly with a sling.

NOTE: Supporting the propeller with the sling may be delayed until all but two mounting bolts and washers have been removed to permit rotating the propeller for ease of bolt removal.

- (a) If the propeller will be reinstalled, and it has been dynamically balanced, make an identifying mark on the propeller hub and a matching mark on the engine flange to make sure of proper orientation during reinstallation to prevent dynamic imbalance.

CAUTION: DISCARD THE PROPELLER MOUNTING BOLTS IF THEY ARE DAMAGED OR CORRODED, OR WHEN THE PROPELLER IS REMOVED FOR OVERHAUL.

- (8) Remove the propeller mounting bolts and washers.

- (a) If the propeller is removed between overhaul intervals, mounting bolts and washers may be reused if they are not damaged or corroded.

CAUTION: USE ADEQUATE PRECAUTIONS TO PROTECT THE PROPELLER ASSEMBLY FROM DAMAGE WHEN IT IS REMOVED FROM THE AIRCRAFT ENGINE AND WHEN IT IS STORED.

- (9) Using the support sling, lift the propeller from the mounting flange.
- (10) Remove and discard the propeller mounting O-ring.
- (11) Install suitable covers on the pitch change rod opening, propeller mounting flange, and engine flange to prevent the introduction of contamination.
- (12) Put the propeller on a suitable cart for transportation.

F. Removal of HC-D3F-7() Propellers

NOTE: Refer to Figures 3-13 through 3-16 for the Beta Valve System.

- (1) Remove the spinner dome in accordance with the section "Spinner Dome Removal" in this chapter.
- (2) If the propeller is equipped with an ice protection system that uses components supplied by Hartzell Propeller Inc., applicable instructions and technical information for the components supplied by Hartzell Propeller Inc. can be found in the following publications available on the Hartzell Propeller Inc. website at www.hartzellprop.com:
 - (a) Manual 180 (30-61-80) - Propeller Ice Protection System Manual
 - (b) Manual 181 (30-60-81) - Propeller Ice Protection Component Maintenance Manual
 - (c) Manual 182 (61-12-82) - Propeller Electrical De-ice Boot Removal and Installation Manual
 - (d) Manual 183 (61-12-83) - Propeller Anti-icing Boot Removal and Installation Manual
- (3) Propeller ice protection system components not supplied by Hartzell Propeller Inc. are controlled by the applicable TC or STC holder's Instructions for Continued Airworthiness (ICA).

WARNING 1: DURING ENGINE INSTALLATION OR REMOVAL, USING THE PROPELLER TO SUPPORT THE WEIGHT OF THE ENGINE IS NOT AUTHORIZED. UNAPPROVED INSTALLATION AND REMOVAL TECHNIQUES MAY CAUSE DAMAGE TO THE PROPELLER THAT MAY LEAD TO FAILURE AND RESULT IN AN AIRCRAFT ACCIDENT.

WARNING 2: DURING PROPELLER REMOVAL, AIRFRAME MANUFACTURER'S MANUALS AND PROCEDURES MUST BE FOLLOWED BECAUSE THEY MAY CONTAIN ISSUES VITAL TO AIRCRAFT SAFETY THAT ARE NOT CONTAINED IN THIS MANUAL OR THE HARTZELL PROPELLER OVERHAUL MANUALS.

WARNING 3: MAKE SURE THE SLING IS RATED UP TO 800 LBS (363 KG) TO SUPPORT THE WEIGHT OF THE PROPELLER ASSEMBLY DURING REMOVAL.

CAUTION: INSTRUCTIONS AND PROCEDURES IN THIS SECTION MAY INVOLVE PROPELLER CRITICAL PARTS. REFER TO THE INTRODUCTION CHAPTER OF THIS MANUAL FOR INFORMATION ABOUT PROPELLER CRITICAL PARTS. REFER TO THE ILLUSTRATED PARTS LIST CHAPTER OF THE APPLICABLE OVERHAUL MANUAL(S) FOR THE IDENTIFICATION OF SPECIFIC PROPELLER CRITICAL PARTS.

- (4) Remove the self-locking nut and spacer from the beta system rod that protrudes from the pitch change seal unit.
- (5) Cut and remove the safety wire (if installed) on the propeller mounting bolts.

- (6) Support the propeller assembly with a sling.

NOTE: Supporting the propeller with the sling may be delayed until all but two mounting bolts and washers have been removed to permit rotating the propeller for ease of bolt removal.

- (7) If the propeller will be reinstalled, and it has been dynamically balanced, make an identifying mark on the propeller hub and a matching mark on the engine flange to ensure proper orientation during reinstallation to prevent dynamic imbalance.

CAUTION: DISCARD THE PROPELLER MOUNTING BOLTS IF THEY ARE DAMAGED OR CORRODED, OR WHEN THE PROPELLER IS REMOVED FOR OVERHAUL.

- (8) Remove the propeller mounting bolts and washers.
- (a) If the mounting bolts and washers are not damaged or corroded, they may be reused when the propeller assembly is reinstalled if removed between overhauls.

CAUTION 1: DO NOT PERMIT THE PROPELLER ASSEMBLY TO HIT OR REST ON THE BETA FEEDBACK ROD. THIS COULD BEND OR OTHERWISE DAMAGE THE ROD.

CAUTION 2: USE ADEQUATE PRECAUTIONS TO PROTECT THE PROPELLER ASSEMBLY FROM DAMAGE WHEN IT IS REMOVED FROM THE AIRCRAFT ENGINE AND WHEN IT IS STORED.

- (9) Using the support sling, lift the propeller from the mounting flange.
- (10) Remove and discard the propeller mounting O-ring.
- (11) Install suitable covers on the pitch change rod opening, propeller mounting flange, and engine flange to prevent the introduction of contamination.
- (12) Put propeller on a suitable cart for transportation.

I G. Removal of the D-751-() Beta Valve Assembly

- (1) Remove the beta light switch away from the beta valve pin per airframe manufacturer's instructions.
- (2) Remove the engine mounted beta system control hardware from the beta valve rod end fitting, per the airframe/engine manufacturer's instructions.
- (3) Loosen the check nut on the push rod spool away from the bushing to break the Loctite® bond.
- (4) Loosen the set screw to clear the threads of the push rod spool and to permit removal of the rod end cap.
- (5) Loosen the rod end cap to break the Loctite bond. Remove the rod end cap from the push rod spool.
- (6) Remove the rod end fitting from the push rod spool.
- (7) Remove the bushing from the push rod spool.
- (8) Remove the check nut from the push rod spool.
- (9) Remove the O-ring from the cavity at the rear of the threaded end of the push rod spool.
- (10) Remove the engine cover from the rear of the engine gear box encircling the beta valve push rod spool in accordance with the airframe or engine manufacturer's instructions.
- (11) Remove and discard the ID and OD O-rings from the engine cover.

WARNING: SPRINGS IN THE ENGINE SHAFT ARE PRELOADED AND MUST BE PROPERLY CONTROLLED WHEN RELEASING THE SPRING RETAINER TO AVOID INJURY.

- (12) Secure the spring retainer and remove the retaining ring that holds the spring retainer in place.
- (13) Remove the spring retainer from the engine shaft and beta valve.
- (14) Remove the spring from the engine shaft and beta valve.
- (15) Slide the beta valve's remaining assembly and push rod spool out of the engine shaft toward where the propeller had been mounted.
- (16) Put all beta valve parts together, including the self locking nut and spacer that were removed to permit the removal of the propeller assembly.

(This page is intentionally blank.)

TESTING AND TROUBLESHOOTING - CONTENTS

1. Operational Tests.....	4-3
A. Initial Run-Up	4-3
B. Post-Run Check.....	4-3
C. Maximum RPM (Static) Hydraulic Low Pitch Stop Check..	4-4
D. Reverse Pitch Stop Adjustment	4-4
E. Feathering Pitch Stop Adjustment.....	4-4
F. Start Lock Adjustment	4-4
G. Propeller Ice Protection System.....	4-4
2. Troubleshooting	4-5
A. Hunting and Surging	4-5
B. Engine Speed Varies with Flight Altitude (or Airspeed)	4-5
C. Loss of Propeller Control	4-6
D. Failure to Feather (or feathers slowly)	4-7
E. Failure to Unfeather	4-7
F. Start Locks (Anti-Feather Latches) Fail to Latch on Shutdown	4-7
G. Vibration.....	4-8
H. Propeller Overspeed	4-9
I. Propeller Underspeed	4-9
J. Oil or Grease Leakage.....	4-10

(This page is intentionally blank.)

1. Operational Tests

Following propeller installation the propeller system must be purged of air, and proper operation verified.

WARNING: REFER TO THE AIRCRAFT MAINTENANCE MANUAL FOR ADDITIONAL PROCEDURES THAT MAY BE REQUIRED AFTER PROPELLER INSTALLATION.

CAUTION: INSTRUCTIONS AND PROCEDURES IN THIS SECTION MAY INVOLVE PROPELLER CRITICAL PARTS. REFER TO THE INTRODUCTION CHAPTER OF THIS MANUAL FOR INFORMATION ABOUT PROPELLER CRITICAL PARTS. REFER TO THE ILLUSTRATED PARTS LIST CHAPTER OF THE APPLICABLE OVERHAUL MANUAL(S) FOR THE IDENTIFICATION OF SPECIFIC PROPELLER CRITICAL PARTS.

A. Initial Run-Up

- (1) Perform engine start and warm-up per the Pilot's Operating Handbook (POH).
- (2) Cycle the propeller control throughout its operating blade angle range from reverse or low, to high (or as directed by the POH).
- (3) Repeat this procedure at least three times to purge air from the propeller hydraulic system and to introduce warmed oil to the cylinder.
- (4) Verify proper operation from reverse or low pitch, to high pitch and throughout operating range.
- (5) Shut down engine in accordance with the POH.
 - (a) Air trapped within the propeller hydraulic cylinder will cause pitch control to be imprecise and may result in propeller surging.

B. Post-Run Check

After engine shutdown, check propeller for signs of engine oil leakage.

C. Maximum RPM (Static) Hydraulic Low Pitch Stop Check

The Maximum RPM (hydraulic low pitch stop) is normally set at the factory per the aircraft manufacturer's requirements, and should not require any additional adjustment.

Adjustments may be required after maintenance or because of specific aircraft variances.

Adjustments must be done in accordance with the airframe manufacturer's specification found in the airframe manufacturer's manual.

D. Reverse Pitch Stop Adjustment

The reverse pitch stop adjustment is set at the factory per the aircraft manufacturer's recommendations. This stop is adjustable only by a certified propeller repair station, aircraft manufacturer, or the Hartzell Propeller Inc. factory.

E. Feathering Pitch Stop Adjustment

The feathering pitch stop is set at the factory per the aircraft manufacturer's recommendations. This stop is adjustable only by a certified propeller repair station, aircraft manufacturer, or the Hartzell Propeller Inc. factory.

F. Start Lock Adjustment

The start locks are set at the factory per manufacturer's recommendations. These stops are adjustable only by a certified propeller repair station, aircraft manufacturer, or the Hartzell Propeller Inc. factory.

G. Propeller Ice Protection System

(1) Electric De-ice System

(a) Consult the Pilot Operating Handbook (POH) (including all supplements) regarding flight into conditions of known icing. The aircraft may not be certificated for flight in known icing conditions, even though propeller de-ice equipment is installed.

(b) Refer to the Anti-ice and De-ice Systems chapter of this manual for functional tests of the de-ice system.

(2) Anti-ice System

- (a) Consult the Pilot Operating Handbook (including all supplements) regarding flight into conditions of known icing. The aircraft may not be certificated for flight in known icing conditions, even though propeller anti-ice equipment is installed.
- (b) Refer to the Anti-ice and De-ice Systems Chapter of this manual for functional tests of the anti-ice system.

(This page is intentionally blank.)

2. Troubleshooting

CAUTION: INSTRUCTIONS AND PROCEDURES IN THIS SECTION MAY INVOLVE PROPELLER CRITICAL PARTS. REFER TO THE INTRODUCTION CHAPTER OF THIS MANUAL FOR INFORMATION ABOUT PROPELLER CRITICAL PARTS. REFER TO THE ILLUSTRATED PARTS LIST CHAPTER OF THE APPLICABLE OVERHAUL MANUAL(S) FOR THE IDENTIFICATION OF SPECIFIC PROPELLER CRITICAL PARTS.

A. Hunting and Surging

Hunting is characterized by a cyclic variation in engine speed above and below desired speed. Surging is characterized by a large increase/decrease in engine speed, followed by a return to set speed after one or two occurrences.

- (1) If propeller is hunting, a repair facility should check:
 - (a) Governor
 - (b) Fuel control
 - (c) Synchrophaser or synchronizer
- (2) If propeller is surging:
 - (a) Perform the steps 1.A.(1) through 1.A.(5) under Operational Tests section in this chapter to release trapped air from the propeller. If surging recurs, it is most likely due to a faulty governor.
 - (b) Hunting and/or surging may also be caused by friction or binding within the governor control, or by internal propeller corrosion, which causes the propeller to react slower to governor commands.
 - 1 Test the propeller on a test bench at a propeller repair facility to isolate these faults.

B. Engine Speed Varies with Flight Altitude (or Airspeed)

- (1) Small variances in engine speed are normal and are no cause for concern.
- (2) Increase in engine speed while descending or increasing airspeed:
 - (a) Governor is not reducing oil volume.
 - (b) Friction in propeller.

- (3) Decrease in engine speed while increasing airspeed:
 - (a) Governor pilot valve is stuck and is excessively decreasing oil volume.
 - (b) Feathering command engaged on propeller pitch control.
 - (4) Increase in engine speed while decreasing airspeed:
 - (a) Governor pilot valve is stuck and is excessively increasing oil volume.
 - (5) Decrease in engine speed while decreasing airspeed:
 - (a) Governor is not increasing oil volume in the propeller.
 - (b) Engine oil transfer system leaking excessively.
 - (c) Friction in propeller.
- C. Loss of Propeller Control
- (1) Propeller goes to uncommanded high pitch (or feather).
 - (a) Loss of propeller oil pressure - check:
 - 1 Governor pressure relief valve.
 - 2 Governor drive.
 - 3 Engine oil supply.
 - (b) Start locks not engaging.
 - (2) Propeller goes to uncommanded low pitch (high RPM).
 - (a) Governor pilot valve sticking.
 - (3) RPM increases with power and airspeed, propeller RPM control has little or no effect.
 - (a) Excessive friction in blade bearings or pitch changing mechanism.
 - (b) Broken feathering spring.
 - (4) RPM control sluggish (especially on reducing RPM).
 - (a) Broken feathering spring.

- D. Failure to Feather (or feathers slowly)
- (1) Broken feathering spring.
 - (2) Check for proper function and rigging of propeller/governor control linkage.
 - (3) Check governor drain function.
 - (4) Propeller must be checked for misadjustment or internal corrosion (usually in blade bearings or pitch changing mechanism) that results in excessive friction. This must be accomplished at a propeller repair facility.
- E. Failure to Unfeather
- (1) Check for proper function and rigging of propeller control linkage.
 - (2) Check governor function.
 - (3) Propeller must be checked for misadjustment or internal corrosion (usually in blade bearings or pitch change mechanism) that results in excessive friction. This must be accomplished at a propeller repair facility.
- F. Start Locks (Anti-feather Latches) Fail to Latch on Shutdown
- (1) Propeller was feathered before shutdown.
 - (2) Shutdown occurred at high RPM with propeller control off the low pitch stop.

The problem may be solved by restarting the engine, placing the propeller control in the proper shutdown position, and then shutting down the engine.
 - (3) Excessive governor pump leakage.

The problem should be referred to an authorized engine repair facility.
 - (4) Broken start lock.

The problem should be referred to an authorized propeller repair facility.

G. Vibration

CAUTION 1: ANY VIBRATION WHICH CAN BE DESCRIBED AS APPEARING SUDDENLY, OR IS ACCOMPANIED BY UNEXPLAINED GREASE LEAKAGE, SHOULD BE INVESTIGATED IMMEDIATELY BY AN AUTHORIZED REPAIR STATION, BEFORE THE NEXT FLIGHT.

CAUTION 2: VIBRATION PROBLEMS DUE TO PROPELLER SYSTEM IMBALANCE ARE NORMALLY FELT THROUGHOUT THE RPM RANGE, WITH THE INTENSITY OF VIBRATION INCREASING WITH RPM. VIBRATION PROBLEMS THAT OCCUR IN A NARROW RPM RANGE ARE A SYMPTOM OF RESONANCE, AND ARE POTENTIALLY HARMFUL TO THE PROPELLER. AVOID OPERATION IN THAT RPM RANGE UNTIL THE PROPELLER CAN BE CHECKED BY AN AUTHORIZED REPAIR STATION.

(1) Check:

- (a) Control surfaces, exhaust system, landing gear doors, etc. for excessive play, which may be causing vibration unrelated to the propeller.
- (b) Uneven lubrication of propeller.
- (c) Proper engine/propeller flange mating.
- (d) Blade track. (Refer to the Inspection and Check chapter of this manual for procedure.)
- (e) Blade angles: Blade angle must be within tolerance between blades and on the propeller as a whole. Refer to the Hartzell Propeller Overhaul Manuals 141 (61-10-41), 142 (61-10-42), 143A (61-10-43) or 158A (61-10-58) for blade angle check procedure.
- (f) Spinner for cracks, improper installation, or "wobble" during operation.
- (g) Static balance.

- (h) Airfoil profile identical between blades (after overhaul or rework for nicks - verify at propeller repair station).
- (i) Hub or blade for damage or cracking.
- (j) Grease or oil leakage from a seemingly solid surface of the hub or blade.
- (k) Blade deformation.
 - 1 Dynamic balancing is recommended after installing or performing maintenance on a propeller. While normally an optional task, it may be required by the engine or airframe manufacturer to make certain the propeller/engine combination is balanced within close tolerances before operation. Refer to the engine or airframe manuals, and the Maintenance Practices chapter of this manual.

H. Propeller Overspeed

(1) Check:

- (a) Low pitch stop adjustment.
- (b) Governor Maximum RPM set too high.
- (c) Broken feathering spring.
- (d) Governor pilot valve jammed, supplying high pressure only.
- (e) Tachometer error.

I. Propeller Underspeed

(1) Check:

- (a) Governor oil pressure low.
- (b) Governor oil passage clogged.
- (c) Tachometer error.

J. Oil or Grease Leakage**(1) General**

- (a) A new propeller may leak slightly during the first several hours of operation. This leakage may be caused by the seating of seals and O-rings, and the slinging of lubricants used during assembly. Such leakage should cease within the first ten hours of operation.

CAUTION: GREASE LEAKAGE THAT CAN BE DESCRIBED AS EXCESSIVE AND APPEARING SUDDENLY, ESPECIALLY WHEN ACCOMPANIED BY VIBRATION, SHOULD BE INVESTIGATED IMMEDIATELY BEFORE NEXT FLIGHT.

(2) Grease Leakage - Probable Cause:

- (a) Improperly torqued or loose lubrication fitting. (Tighten the fitting).
- (b) Defective lubrication fitting. (Replace the fitting).
- (c) Faulty seal at the blade socket between the blade hub. (Refer to an authorized propeller repair facility for replacement of the seal).
- (d) HC-(D,E)(4,5)()-3(): Leakage from the hub and beta rod interface.
- 1 Over greased hub. (Refer to an authorized propeller repair facility for removal of excess grease.)
 - 2 Faulty seal. (Refer to an authorized propeller repair facility for replacement of seal.)
- (e) Cracked hub. A cracked hub is often indicated by grease emerging from a seemingly solid surface, especially in the blade arm. (Refer to an authorized propeller repair facility.)

I (3) Oil Leakage - Probable Cause

(a) Leaks between the hub and engine - Faulty or missing seal between the propeller hub and the engine flange.

(b) Leaks between the hub and cylinder - Faulty or missing seal between the hub and the cylinder.

Refer seal replacement to an approved repair facility.

(c) Leaks between the hub halves, beta rod and hub, and lubrication fittings - Faulty seal(s) between hub and the pitch change rod.

Refer seal replacement to an approved repair facility.

I (d) Leaks from the front of the cylinder or through start locks - Faulty seal(s) between the piston and cylinder or piston and pitch change rod.

I 1 Refer seal replacement to an approved repair facility.

(This page is intentionally blank.)

INSPECTION AND CHECK - CONTENTS

1. Pre-Flight Checks	5-3
2. Operational Checks	5-5
3. Post-Flight Checks	5-6
A. General	5-6
B. Requirements.....	5-6
4. Required Periodic Inspections and Maintenance	5-7
A. Periodic Inspections.....	5-7
B. Periodic Maintenance	5-9
C. Airworthiness Limitations	5-9
D. Overhaul Periods	5-10
5. Inspection Procedures.....	5-18
A. Blade Damage	5-18
B. Grease or Oil Leakage.....	5-18
C. Vibration.....	5-20
D. Tachometer Inspection.....	5-23
E. Blade Track.....	5-25
F. Loose Blades	5-27
G. Preload Plate Set Screw	5-28
H. Corrosion	5-28.1
I. Spinner Damage	5-28.1
J. Electric De-ice System.....	5-28.1
K. Anti-ice System	5-28.1
L. Unique Identification (UID) Plate Inspection	5-28.1
6. Special Inspections.....	5-32
A. Overspeed/Overtorque	5-32
B. Propeller Ground Idle Operating Restrictions	5-33
C. Lightning Strike	5-39
D. Foreign Object Strike/Ground Strike.....	5-40
E. Fire Damage or Heat Damage.....	5-42
7. Long Term Storage	5-42

FIGURES

Checking Blade Track.....	Figure 5-1	5-24
Blade Play	Figure 5-2.....	5-24
Turbine Engine Overspeed Limits	Figure 5-3.....	5-30
Turbine Engine Overtorque Limits.....	Figure 5-4.....	5-31
Example of an Evaluation of Ground Idle RPM Check	Figure 5-5.....	5-34
Corrective Action Required.....	Figure 5-6.....	5-35

1. Pre-Flight Checks

Follow propeller preflight inspection procedures as specified in the aircraft maintenance manual, air carrier's operational specifications, or this manual. In addition, perform the following inspections:

CAUTION: INSTRUCTIONS AND PROCEDURES IN THIS SECTION MAY INVOLVE PROPELLER CRITICAL PARTS. REFER TO THE INTRODUCTION CHAPTER OF THIS MANUAL FOR INFORMATION ABOUT PROPELLER CRITICAL PARTS. REFER TO THE ILLUSTRATED PARTS LIST CHAPTER OF THE APPLICABLE OVERHAUL MANUAL(S) FOR THE IDENTIFICATION OF SPECIFIC PROPELLER CRITICAL PARTS.

A. Blades

- (1) Visually inspect the entire blade (lead, trail, face, and camber sides) for nicks, gouges, and cracks. Refer to the Maintenance Practices chapter of this manual, for blade repair information. Normal blade lead edge erosion (sand-blasted appearance) is acceptable, and does not require removal before further flight.
- (2) Visually inspect the blades for lightning strike. Refer to Lightning Strike Damage information in the Special Inspections section of this chapter.

B. Inspect the spinner and visible blade retention components for damage or cracks. Repair or replace components as required before further flight.

C. Check for loose/missing hardware. Retighten or reinstall as necessary.

WARNING: ABNORMAL GREASE LEAKAGE CAN BE AN INDICATION OF A FAILING PROPELLER BLADE OR BLADE RETENTION COMPONENT. AN IN-FLIGHT BLADE SEPARATION CAN RESULT IN A CATASTROPHIC AIRCRAFT ACCIDENT.

D. Inspect for grease and oil leakage and determine its source.

- E. Check the blades for radial play or movement of the blade tip (in and out or back and forth). Refer to Loose Blades in the Inspection Procedures section of this chapter for blade play limits.
- F. Inspect de-ice boots (if installed) for damage. Refer to the Anti-ice and De-ice Systems chapter of this manual for inspection information.
- G. Check the propeller speed control and operation from reverse or low pitch to high pitch, using the procedure specified in the Pilot Operating Handbook (POH) for the aircraft.

WARNING: ABNORMAL VIBRATION CAN BE AN INDICATION OF A FAILING PROPELLER BLADE OR BLADE RETENTION COMPONENT. AN IN-FLIGHT BLADE SEPARATION CAN RESULT IN A CATASTROPHIC AIRCRAFT ACCIDENT.

- H. Perform initial run-up as outlined in Operational Tests section of the Testing and Troubleshooting chapter of this manual.
- I. Check for any abnormal vibration during this run-up. If vibration occurs, shut the engine down, determine the cause, and correct it before further flight. Refer to the Vibration section in the Testing and Troubleshooting chapter of this manual.
- J. Refer to Inspection Procedures section of this chapter for additional inspection information and possible corrections to any discrepancies discovered as a result of pre-flight checks.

2. Operational Checks

CAUTION: INSTRUCTIONS AND PROCEDURES IN THIS SECTION MAY INVOLVE PROPELLER CRITICAL PARTS. REFER TO THE INTRODUCTION CHAPTER OF THIS MANUAL FOR INFORMATION ABOUT PROPELLER CRITICAL PARTS. REFER TO THE ILLUSTRATED PARTS LIST CHAPTER OF THE APPLICABLE OVERHAUL MANUAL(S) FOR THE IDENTIFICATION OF SPECIFIC PROPELLER CRITICAL PARTS.

- A. Following propeller installation or as required, perform initial run-up as outlined in Operational Tests in the Testing and Troubleshooting chapter of this manual.
- B. Check the propeller speed control and operation from reverse or low pitch to high pitch, using the procedure specified in the Pilot Operating Handbook (POH) for the aircraft.

WARNING: ABNORMAL VIBRATION CAN BE AN INDICATION OF A FAILING PROPELLER BLADE OR BLADE RETENTION COMPONENT. AN IN-FLIGHT BLADE SEPARATION CAN RESULT IN A CATASTROPHIC AIRCRAFT ACCIDENT.

- C. Check for any abnormal vibration during this run-up. If vibration occurs, shut the engine down, determine the cause, and correct it before further flight. Refer to the Vibration section in the Testing and Troubleshooting chapter of this manual.
- D. Refer to Periodic Inspections in this chapter for additional inspection information and possible corrections to any discrepancies discovered as a result of Pre-Flight Checks.
- E. Refer to the airframe manufacturer's manual for additional operational checks.

3. Post-Flight Checks

CAUTION: INSTRUCTIONS AND PROCEDURES IN THIS SECTION MAY INVOLVE PROPELLER CRITICAL PARTS. REFER TO THE INTRODUCTION CHAPTER OF THIS MANUAL FOR INFORMATION ABOUT PROPELLER CRITICAL PARTS. REFER TO THE ILLUSTRATED PARTS LIST CHAPTER OF THE APPLICABLE OVERHAUL MANUAL(S) FOR THE IDENTIFICATION OF SPECIFIC PROPELLER CRITICAL PARTS.

A. General

- (1) The following are affected by these post-flight requirements:
 - (a) Piaggio P-180 aircraft with HC-E5N-3(A)/HE8218 and HC-E5N-3(A)/LE8218 propellers
- (2) As a result of the “pusher” configuration, propeller blades on affected aircraft are exposed to hot exhaust gasses, which makes them more susceptible to erosion and corrosion. Corrosion pitting in highly stressed areas of propeller blade shanks is highly undesirable; therefore, additional inspections and corrosion preventative measures are required.

B. Requirements

- (1) Perform blade cleaning within three days after any flight.

NOTE: It is recommended to perform blade cleaning after the last flight of each day. This is a recommendation and is not mandatory.

(a) Blade Cleaning

- 1 Using cloth dampened with Stoddard solvent or jet fuel, wipe each propeller blade to remove engine exhaust residue.
- 2 If there is visual evidence of corrosion or bare metal exposed as a result of paint erosion, repair at the next scheduled inspection is recommended.

4. Required Periodic Inspections and Maintenance

CAUTION: INSTRUCTIONS AND PROCEDURES IN THIS SECTION MAY INVOLVE PROPELLER CRITICAL PARTS. REFER TO THE INTRODUCTION CHAPTER OF THIS MANUAL FOR INFORMATION ABOUT PROPELLER CRITICAL PARTS. REFER TO THE ILLUSTRATED PARTS LIST CHAPTER OF THE APPLICABLE OVERHAUL MANUAL(S) FOR THE IDENTIFICATION OF SPECIFIC PROPELLER CRITICAL PARTS.

A. Periodic Inspections

- (1) Accomplish a detailed inspection at 400 hour intervals, not to exceed twelve (12) months.
 - (a) Inspection and maintenance specified by an airframe manufacturer's maintenance program and approved by the applicable airworthiness agency may not coincide with the inspection time interval specified. In this situation the airframe manufacturer's schedule may be applied with the exception that the calendar limit for the inspection interval may not exceed (12) calendar months.
 - (b) Refer to Inspection Procedures in this chapter for additional inspection information and possible corrections to any discrepancies discovered as a result of the Periodic Inspection.
- (2) Remove the spinner.
- (3) Visually inspect the blades for nicks and cracks. If any damage is discovered, refer to the Blade Repairs section in the Maintenance Practices chapter of this manual for additional information.
 - (a) For Piaggio P-180 aircraft with HC-E5N-3(A)/HE8218 and HC-E5N-3(A)L/LE8218 propellers:

CAUTION: ESTABLISH MORE FREQUENT INTERVALS FOR INSPECTION IF SERVICE EXPERIENCE INDICATES THAT SEVERE CORROSION IS FOUND DURING INSPECTIONS.

- 1** Perform blade corrosion/paint inspections at intervals not to exceed 150 hours of operation, 12 calendar months, or at annual inspection, whichever occurs first.
 - a** For scheduling purposes, the inspection interval has a maximum 10 percent additional non-cumulative flight hour tolerance.
 - b** For example, the initial 150 hour inspection is overflowed to 160 hours, and then inspected at this time. The next inspection must be accomplished 140 flight hours from previous inspection.
- 2** Using Stoddard-type solvent, thoroughly clean each blade shank in areas exposed to engine exhaust and remove all foreign matter/exhaust residue.
- 3** Visually examine the condition of the paint and any corrosion indications.
- 4** Paint must be in good condition in the area exposed to exhaust gasses. Repair and repainting is required if:
 - a** Any of the underlying aluminum blade is exposed.
 - b** There are any indications of corrosion, such as pitting or pinpoint “blisters” or “spiders”.
- 5** All corrosion indications require repair and subsequent repainting.
 - a** Refer to FAA Advisory Circular AC 43-4A (or subsequent revision) for additional information concerning corrosion. This circular provides definitions, repair procedures, safety precautions, etc.

- 6 If repair and repainting are required, perform the procedures in accordance with Hartzell Propeller Inc. Service Bulletin 181A.
 - 7 If there is severe corrosion, refer the propeller to an appropriately licensed service facility.
- (4) Inspect all visible propeller parts for cracks, wear or unsafe conditions.
- (5) Check for oil and grease leaks. Refer Inspection Procedures in this chapter.
- (6) If a blade track problem is suspected, check the blade track. Refer to Inspection Procedures in this chapter.
- (7) Check preload plate set screw. Refer to the Preload Plate Set Screw information in the Inspection Procedures section of this chapter.
- (8) Make an entry in the log book verifying the inspections.

B. Periodic Maintenance

Lubricate the propeller assembly. Refer to Lubrication in the Maintenance Practices chapter of this manual for intervals and procedures.

C. Airworthiness Limitations

- (1) Certain components, as well as the entire propeller may have specific life limits established as part of the certification by the FAA. Such limits call for mandatory replacement of specified parts after a defined number of hours and/or cycles of use.
- (2) Life limited component times may exist for the propeller models included in this manual. Refer to the Airworthiness Limitations chapter of this manual.
- (3) Operators are urged to keep informed of airworthiness information via Hartzell Propeller Inc. Service Bulletins and Service Letters, which are available from Hartzell Propeller Inc. distributors or from the Hartzell Propeller Inc. factory by subscription. Selected information is also available on Hartzell Propeller's website at www.hartzellprop.com.

D. Overhaul Periods**(1) General**

- (a) In flight, the propeller is constantly subjected to vibration from the engine and the airstream, as well as high centrifugal forces.
- (b) The propeller is also subject to corrosion, as well as general deterioration due to aging. Under these conditions, metal fatigue or mechanical failures can occur.
- (c) To protect your safety and your investment, and to maximize the safe operating lifetime of your propeller, it is essential that a propeller be properly maintained and overhauled according to the recommended service procedures.
- (d) Agricultural category aircraft are defined as aircraft used as aerial applicators as defined in 14 CFR 137.3, as specified in FAA order 8700.1, including forest fire-fighting activities. These operations may expose the propeller to a relatively severe chemical/corrosive environment. Once installed on an agricultural aircraft, the 36 month overhaul limit is to be maintained until overhaul is performed, even if the propeller is later installed on a non-agricultural aircraft.
- (e) Acrobatic (aerobatic) category aircraft are defined as certificated acrobatic (aerobatic) category aircraft or other aircraft routinely exposed to maneuvers beyond those specified for utility category aircraft as defined in 14 CFR 23.3. Once a propeller is used on an aerobatic aircraft, the specified overhaul times for an aerobatic propeller are to be maintained until overhaul is performed, even if the propeller is later installed on a non-aerobatic aircraft.
- (f) Fire fighting category aircraft are defined as aircraft used solely and exclusively for fire fighting operations and related training flights.
- (g) This section contains the overhaul limits for Hartzell Propeller Inc. lightweight propellers installed on turbine engines.

CAUTION 1: OVERHAUL PERIODS LISTED BELOW, ALTHOUGH CURRENT AT THE TIME OF PUBLICATION, ARE FOR REFERENCE PURPOSES ONLY. OVERHAUL PERIODS MAY BE INCREASED OR DECREASED AS A RESULT OF ENGINEERING EVALUATION.

CAUTION 2: CHECK THE LATEST REVISION OF HARTZELL PROPELLER INC. SERVICE LETTER HC-SL-61-61Y FOR THE MOST CURRENT INFORMATION.

(2) For HC-(D,E)4(A,N,P,W)-() series propellers

(a) HC-(D,E)4(A,N,P,W)-() series propellers used for normal, commuter, or transport category aircraft are to be overhauled as follows:

- 1 If the propeller or the aluminum hub was manufactured or overhauled after October 1991, perform overhaul at 4000 hours of operation or 72 calendar months, whichever occurs first.
- 2 If the propeller or the aluminum hub was manufactured or overhauled before October 1991, perform overhaul at 4000 hours of operation or 60 calendar months, whichever occurs first.
 - a Propellers or aluminum hubs manufactured or overhauled since October 1991 are required to have the hub internal surface painted for additional corrosion protection.
 - b Hubs that have not had the internal surface painted have a 60 calendar month overhaul limit until the hub internal surface is painted for corrosion protection.
 - c After the hub internal surface is painted, the calendar limit increases to 72 months.

- (b) HC-(D,E)4(A,N,P,W)-() series propellers used on utility or acrobatic (aerobatic) category aircraft are to be overhauled as follows:
- 1 If the propeller or the aluminum hub was manufactured or overhauled after October 1991, perform overhaul at 3500 hours of operation or 72 calendar months, whichever occurs first.
 - 2 If the propeller or the aluminum hub was manufactured or overhauled before October 1991, perform overhaul at 3500 hours of operation or 60 calendar months, whichever occurs first.
 - a Propellers or aluminum hubs manufactured or overhauled since October 1991 are required to have the hub internal surface painted for additional corrosion protection.
 - b Hubs that have not had the internal surface painted have a 60 calendar month overhaul limit until the hub internal surface is painted for corrosion protection.
 - c After the hub internal surface is painted, the calendar limit increases to 72 months.
 - 3 Once used on utility or acrobatic (aerobatic) category aircraft, the 3500 hours overhaul limit is to be maintained until an overhaul is accomplished, even if propeller is later installed on normal, commuter, or transport category aircraft.

- (c) HC-(D,E)4(A,N,P,W)-() series propellers used on agricultural category aircraft are to be overhauled as follows:
- 1 Option 1 - Perform overhaul at 3500 hours of operation or 36 calendar months, whichever occurs first.
 - a Once used on agricultural aircraft, the 36 month overhaul limit is to be maintained until an overhaul is accomplished, even if propeller is later installed on other category aircraft.
 - 2 Option 2 - If maintained and inspected in accordance with Hartzell Propeller Inc. Service Letter HC-SL-61-255, perform overhaul at 3500 hours of operation or 60 calendar months, whichever occurs first.
- (d) HC-(D,E)4(A,N,P,W)-() series propellers used on fire fighting category aircraft, are to be overhauled at 3500 hours of operation or 60 calendar months, whichever occurs first.

- (3) For HC-E5N-3() series propellers
- (a) HC-E5N-3() series propellers used for normal, commuter, or transport category aircraft are to be overhauled as follows:
- 1 If the propeller or the aluminum hub was manufactured or overhauled after October 1991, perform overhaul at 3600 hours of operation or 72 calendar months, whichever occurs first.
 - 2 If the propeller or the aluminum hub was manufactured or overhauled before October 1991, perform overhaul at 3600 hours of operation or 60 calendar months, whichever occurs first.
 - a Propellers or aluminum hubs manufactured or overhauled since October 1991 are required to have the hub internal surface painted for additional corrosion protection.
 - b Hubs that have not had the internal surface painted have a 60 calendar month overhaul limit until the hub internal surface is painted for corrosion protection.
 - c After the hub internal surface is painted, the calendar limit increases to 72 months.

- (b) HC-E5N-3() series propellers used on utility or acrobatic (aerobatic) category aircraft are to be overhauled as follows:
- 1 If the propeller or the aluminum hub was manufactured or overhauled after October 1991, perform overhaul at 3000 hours of operation or 72 calendar months, whichever occurs first.
 - 2 If the propeller or the aluminum hub was manufactured or overhauled before October 1991, perform overhaul at 3000 hours of operation or 60 calendar months, whichever occurs first.
 - a Propellers or aluminum hubs manufactured or overhauled since October 1991 are required to have the hub internal surface painted for additional corrosion protection.
 - b Hubs that have not had the internal surface painted have a 60 calendar month overhaul limit until the hub internal surface is painted for corrosion protection.
 - c After the hub internal surface is painted, the calendar limit increases to 72 months.
 - 3 Once used on utility or acrobatic (aerobatic) category aircraft, the 3000 hours overhaul limit is to be maintained until an overhaul is accomplished, even if propeller is later installed on normal, commuter, or transport category aircraft.

- (c) HC-E5N-3() series propellers used on agricultural category aircraft are to be overhauled as follows:
- 1 Option 1 - Perform overhaul at 3000 hours of operation or 36 calendar months, whichever occurs first.
 - a Once used on agricultural aircraft, the 36 month overhaul limit is to be maintained until an overhaul is accomplished, even if propeller is later installed on other category aircraft.
 - 2 Option 2 - If maintained and inspected in accordance with Hartzell Propeller Inc. Service Letter HC-SL-61-255, perform overhaul at 3000 hours of operation or 60 calendar months, whichever occurs first.
- (d) For HC-E5N-3() series propellers used on fire fighting category aircraft are to be overhauled at 3000 hours of operation or 60 calendar months, whichever occurs first.

- (4) For HC-D3F-7 series propellers
- (a) HC-D3F-7 series propellers used for normal, commuter, or transport category aircraft are to be overhauled as follows:
- 1 If the propeller or the aluminum hub was manufactured or overhauled after October 1991, perform overhaul at 3000 hours of operation or 72 calendar months, whichever occurs first.
 - 2 If the propeller or the aluminum hub was manufactured or overhauled before October 1991, perform overhaul at 3000 hours of operation or 60 calendar months, whichever occurs first.
 - a Propellers or aluminum hubs manufactured or overhauled since October 1991 are required to have the hub internal surface painted for additional corrosion protection.
 - b Hubs that have not had the internal surface painted have a 60 calendar month overhaul limit until the hub internal surface is painted for corrosion protection.
 - c After the hub internal surface is painted, the calendar limit increases to 72 months.
- (b) HC-D3F-7 series propellers used on agricultural category aircraft are to be overhauled as follows:
- 1 Option 1 - Perform overhaul at 3000 hours of operation or 36 calendar months, whichever occurs first.
 - 2 Option 2 - If maintained and inspected in accordance with Hartzell Propeller Inc. Service Letter HC-SL-61-255, perform overhaul at 3000 hours of operation or 60 calendar months, whichever occurs first.
- (c) HC-D3F-7 series propellers used on fire fighting category aircraft are to be overhauled at 3000 hours of operation or 60 calendar months, whichever occurs first.

5. Inspection Procedures

CAUTION: INSTRUCTIONS AND PROCEDURES IN THIS SECTION MAY INVOLVE PROPELLER CRITICAL PARTS. REFER TO THE INTRODUCTION CHAPTER OF THIS MANUAL FOR INFORMATION ABOUT PROPELLER CRITICAL PARTS. REFER TO THE ILLUSTRATED PARTS LIST CHAPTER OF THE APPLICABLE OVERHAUL MANUAL(S) FOR THE IDENTIFICATION OF SPECIFIC PROPELLER CRITICAL PARTS.

The inspections detailed below are made on a regular basis, either before flight, or if a problem is noted. Possible corrections to problems discovered during inspections, additional inspections, and limits are detailed in the following inspection procedures.

A. Blade Damage

Refer to Blade Repairs section in the Maintenance Practices chapter of this manual for information regarding blade damage.

B. Grease or Oil Leakage

NOTE: A new or newly overhauled propeller may leak slightly during the first several hours of operation. This leakage may be caused by the seating of seals and O-rings, and the slinging of lubricants used during assembly. Such leakage should cease within the first ten hours of operation.

Leakage that persists beyond the first ten hours of operation on a new or newly overhauled propeller, or that occurs on a propeller that has been in service for some time will require repair. A determination should be made as to the source of the leak. The only leakage that is field repairable is the removal and replacement of the O-ring seal between the engine and propeller flange. All other leakage repairs should be referred to an authorized propeller repair station. An instance of abnormal grease leakage should be inspected following the procedure below:

- (1) Remove the spinner dome.

- CAUTION:** PERFORM A VISUAL INSPECTION WITHOUT CLEANING THE PARTS. A TIGHT CRACK IS OFTEN EVIDENT DUE TO TRACES OF GREASE EMANATING FROM THE CRACK. CLEANING CAN REMOVE SUCH EVIDENCE AND MAKE A CRACK VIRTUALLY IMPOSSIBLE TO SEE.
- (2) Perform a visual inspection for cracks in the hub. A crack may be readily visible, or may be indicated by grease leaking from a seemingly solid surface. Extra attention should be given to the blade retention area of the hub.
 - (3) Perform a visual inspection of the hub, blades and blade retention areas to locate the origin of leakage. If the origin of the grease leakage is determined to be a noncritical part, such as an O-ring, gasket or sealant, repairs can be accomplished during scheduled maintenance.
 - (4) If cracks are suspected, additional inspections must be performed before further flight. These inspections must be performed by qualified personnel at an appropriately licensed propeller repair facility to verify the condition. Such inspections typically include disassembly of the propeller followed by inspection of parts, using nondestructive methods in accordance with published procedures.
 - (5) If cracks or failing components are found, these parts must be replaced before further flight. Report such occurrences to airworthiness authorities and to Hartzell Propeller Inc. Product Support.

C. Vibration

Instances of abnormal vibration should be investigated immediately. If the cause of the vibration is not readily apparent, the propeller may be inspected following the procedure below:

NOTE: It may sometimes be difficult to readily identify the cause of abnormal vibration. Vibrations may originate in the engine, propeller, or airframe. Troubleshooting procedures typically begin with an investigation of the engine. Airframe components, such as engine mounts or loose landing gear doors, can also be the source of vibration. When investigating an abnormal vibration, the possibility of a failing blade or blade retention component should be considered as a potential source of the problem.

- (1) Perform troubleshooting and evaluation of possible sources of vibration in accordance with engine or airframe manufacturer's instructions.
- (2) Refer to Vibration section in the Testing and Troubleshooting chapter of this manual. Perform the checks to determine possible cause of the vibration. If no cause is found, proceed with steps 4.C.(3) through 4.C.(8).
- (3) Remove the spinner dome.
- (4) Perform a visual inspection for cracks in the hub and blades.
- (5) If cracks are suspected, additional inspections must be performed before further flight. These inspections must be performed by qualified personnel at an appropriately licensed propeller repair facility to verify the condition. Such inspections typically include disassembly of the propeller followed by inspection of parts, using nondestructive methods in accordance with published procedures.

- (6) Check the blades and compare blade to blade differences:
- (a) Inspect the propeller blades for unusual looseness or movement. Refer to Loose Blades in this section.
 - (b) Check blade track. Refer to Blade Track in this section.

CAUTION: DO NOT USE BLADE PADDLES TO TURN BLADES.

- (c) Manually (by hand) attempt to turn the blades (change pitch). Do not use a blade paddles.
 - (d) Visually check for damaged blades.
- (7) If abnormal blade conditions or damage are found, perform additional inspections (by qualified personnel at an appropriately licensed propeller repair facility) to evaluate the condition. Refer to the Blade Repairs section in the Maintenance Practices chapter of this manual.
- (8) If cracks or failing components are found, these parts must be replaced before further flight. Report such occurrences to airworthiness authorities and Hartzell Propeller Inc. Product Support.

(This page is intentionally blank.)

D. Tachometer Inspection

WARNING: OPERATION WITH AN INACCURATE TACHOMETER MAY RESULT IN OPERATION AT A RESTRICTED RPM AND DAMAGING HIGH STRESSES. BLADE LIFE WILL BE SHORTENED AND COULD RESULT IN CATASTROPHIC FAILURE.

NOTE: An appropriately licensed propeller repair facility may also be able to perform an engine tachometer inspection.

- (1) For installations that use a mechanical tachometer, perform the following tachometer inspection.
 - (a) Use a hand held tachometer to verify the accuracy of the engine tachometer at 100 hour intervals or at annual inspection, whichever occurs first.
 - (b) Hartzell Propeller Inc. recommends using a tachometer that is accurate within +/- 10 RPM, has NIST calibration (traceable), and has an appropriate calibration schedule.

W10144

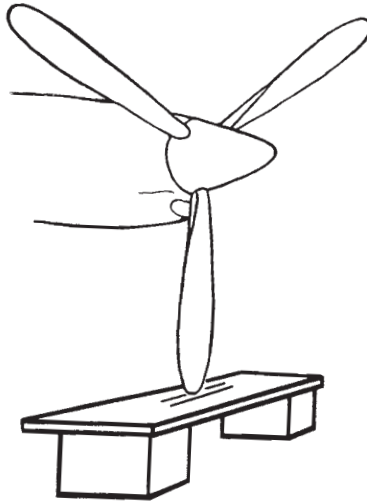

Checking Blade Track
Figure 5-1

W10143

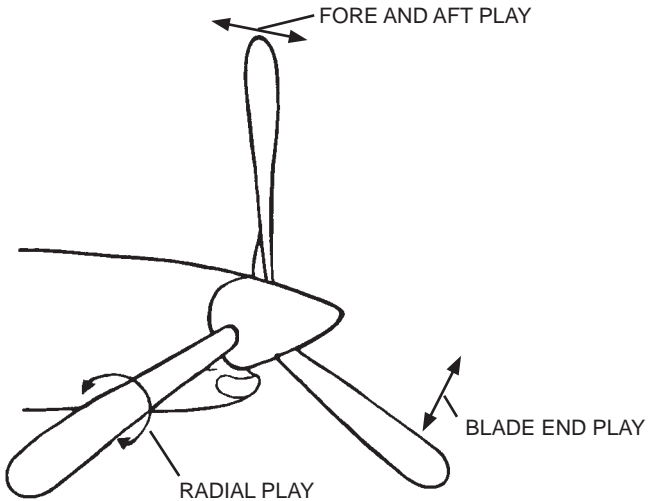

Blade Play
Figure 5-2

E. Blade Track

- (1) If a blade track problem is suspected, examine the blade track as follows:
- (2) For -2 and -3 turbines only, move the propeller to low pitch.
 - (a) Remove the screws and washers that attach the spinner dome to the engine side bulkhead.
 - (b) Remove the spinner dome and set it aside.
 - (c) Remove forward bulkhead and spacers from the forward end of the cylinder.
 - (d) If applicable, remove the bolt, nut, and washer from the pitch change rod.

NOTE: Removal of the plug and O-ring is not required unless an early style propeller unfeathering tool that threads internally is used.

CAUTION 1: DO NOT ATTEMPT TO INSTALL AND USE THE PROPELLER UNFEATHERING TOOL WITHOUT REMOVING THE PITCH CHANGE ROD SAFETY BOLT. BOLT REMOVAL IS NECESSARY TO MAKE SURE OF ADEQUATE THREAD ENGAGEMENT OF THE TOOL.

CAUTION 2: DO NOT ATTEMPT TO MOVE THE PROPELLER BLADES BEYOND THE LOW PITCH MECHANICAL STOPS, IF APPLICABLE.

- (e) Install propeller unfeathering tool part number 9943HART-001 or equivalent.
 - 1** Screw the threaded rod of the tool onto the end of the pitch change rod as far as possible. Hand tighten.
 - 2** Slide the cylindrical portion of the tool over the threaded rod and against the propeller cylinder.
 - 3** Apply a small amount of lubricant or anti-seize compound to the threads of the 1-1/2 inch nut of the unfeathering tool.

- 4 Install the 1-1/2 inch nut onto the threaded rod of the unfeathering tool.
- 5 Turn the 1-1/2 inch nut down until it contacts the thrust bearing.
- 6 Continue turning the nut until the blades move to low pitch.

(3) Check blade track as follows:

NOTE: An accurate blade track inspection cannot be accomplished with the propeller in feather position.

CAUTION: FOR -5 TURBINES ONLY, MAKE SURE THAT THE ENGINE WAS SHUT DOWN WITH THE PROPELLER ON THE LATCHES.

- (a) Chock the aircraft wheels securely.
- (b) Refer to Figure 5-1. Place a fixed reference point beneath the propeller, within 0.25 inch (6.4 mm) of the lowest point of the propeller arc.

NOTE: This reference point may be a flat board with a sheet of paper attached to it. The board may then be blocked up to within 0.25 inch (6.4 mm) of the propeller arc.

- (c) Rotate the propeller by hand in the direction of normal rotation until a blade points directly at the paper.
- (d) Mark the position of the blade tip in relation to the paper.
- (e) Repeat this procedure with the remaining blades.
- (f) Tracking tolerance is ± 0.125 inch (3.18 mm) or 0.25 inch (6.4 mm) total.

(4) Possible Correction

- (a) Remove foreign matter from the propeller mounting flange.
- (b) If no foreign matter is present, refer to an appropriately licensed propeller repair facility.

F. Loose Blades

Refer to Figure 5-2. Limits for blade looseness are as follows:

End Play	See Note Below
Fore & Aft Play	See Note Below
In & Out	None
Radial Play (pitch change)	± 0.5 degree (1 degree total)

NOTE: Blades are intended to be tight in the propeller, however slight movement is acceptable if the blade returns to its original position when released. Blades with excessive movement, or that do not return to their original position when released may indicate internal wear or damage that should be referred to an authorized propeller repair station.

G. Preload Plate Set Screw

- (1) The following inspection only applies to propellers that have not been overhauled since March of 1997.

NOTE: Propellers that have been overhauled after March of 1997 have had the new design preload plate set screw installed in accordance with Hartzell Propeller Inc. Service Bulletin HC-SB-61-225.

- (2) Manually rotate the propeller and listen for possible noise caused by a broken set or jam nut that may be loose in the propeller hub.
- (3) If there is noise indicating a loose part or the propeller blades do not go completely to feather, remove the propeller. Send the propeller to a repair station for disassembly and inspection for a possible broken preload plate set screw.
 - (a) If a broken set screw is found, the propeller must be inspected for damage that may have been caused by the broken set screw.
 - (b) Report any such incidents to the Hartzell Propeller Inc. Product Support Department.

H. Corrosion

WARNING: REWORK THAT INVOLVES COLD WORKING THE METAL, RESULTING IN CONCEALMENT OF A DAMAGED AREA IS NOT PERMITTED.

- (1) Corrosion of any type on the hub, or heavy corrosion on other parts that results in severe pitting, must be referred to an authorized propeller repair station.

I. Spinner Damage

- (1) Inspect the spinner for cracks, missing hardware, or other damage. Refer to Hartzell Propeller Inc. Manual 127 (61-16-27) or an appropriately licensed propeller repair facility for spinner damage acceptance and repair information. Contact the local airworthiness authority for repair approval.

J. Electric De-ice System

- (1) Refer to the Anti-ice and De-ice Systems chapter of this manual for inspection procedures.

K. Anti-ice System

- (1) Refer to the Anti-ice and De-ice Systems chapter of this manual for inspection procedures.

L. Unique Identification (UID) Plate Inspection**(1) General**

- (a) Specific installations require selected aircraft components to have a unique identification that is compatible with Military Standard MIL-STD-130M.
- (b) The UID plate incorporates a laser etched scan code to identify the manufacturer's cage code, propeller IDS/item number, and propeller serial number.
- (c) The cage code, propeller IDS/item number, and serial number are also laser etched on the UID plate.
- (d) On a propeller, the UID plate is located on the cylinder.
- (e) When initially installing the UID plate, the one (1) washer B-3837-0463 and one (1) screw B-3841-5 are replaced with four (4) washers B-3837-0432 and four (4) screws B-3841-6.

(2) Inspection Procedure

- (a) If the UID plate is damaged, the scan code is visibly damaged, or the scan code is not scannable, replace the UID plate.

1 Order a new UID plate.

- a** Contact Hartzell Propeller Inc. New Parts Sales to order the UID plate and the B-3837-0432 washers and B-3841-6 screws that are necessary for installation of the UID plate.

NOTE: A serial number specific UID plate cannot be manufactured until the order is received and the serial number requested is verified.

2 When the new UID plate and the B-3837-0432 washers and B-3841-6 screws that are necessary for installation of the UID plate are available, complete the UID plate removal and installation.

- a** For removal of the UID plate, follow steps 5.L.(2)(c)**1** through 5.L.(2)(c)**4c** in this section.
- b** For installation of the UID plate, follow steps 5.L.(2)(d)**2** through 5.L.(2)(d)**8** in this section.

- (b) If the UID plate is required, but has not yet been installed, install a new UID plate.

1 Order a new UID plate.

- a** Contact Hartzell Propeller Inc. New Parts Sales to order the UID plate and the B-3837-0432 washers and B-3841-6 screws that are necessary for installation of the UID plate.

NOTE: A serial number specific UID plate cannot be manufactured until the order is received and the serial number requested is verified.

- 2 When the new UID plate and the B-3837-0432 washers and B-3841-6 screws that are necessary for installation of the UID plate are available, complete the UID plate installation, in accordance with steps 5.L.(2)(d)1 through 5.L.(2)(d)8 in this section.
- (c) Removal of the UID plate.
 - 1 Remove and discard the safety wire between the B-3841-6 screw on the cylinder and the drilled thin hex nut on the reverse adjust sleeve unit.
 - 2 Remove and discard the B-3841-6 screws and the B-3837-0432 washers from the cylinder.
 - 3 Remove the UID plate from the cylinder.
 - 4 Make the UID plate unserviceable using one of these methods:
 - a Cut the plate in half through the scan code.
 - b Sand the plate to remove the scan code completely.
 - c Use any other method identified and/or required by the military/government authority that requires the use of the plate.
- (d) Installation of the UID plate.
 - 1 If a UID plate was not removed, follow these additional steps:
 - a Remove and discard the safety wire between the B-3841-5 screw on the cylinder and the drilled thin hex nut on the reverse adjust sleeve unit.
 - b Remove and discard the B-3841-5 screw and the B-3837-0463 washers from the cylinder.
 - 2 Examine the UID plate and the propeller hub to make sure that the serial numbers match.
 - 3 With the laser etched side out, align the four (4) screw holes in the UID plate with the four (4) screw holes in the cylinder and hold in place.

- 4 Apply one drop of Loctite 222 to one (1) of the B-3841-6 screws.
 - 5 Install one (1) B-3837-0432 washer onto the B-3841-6 screw.
 - 6 Install the washer and screw into one of the four (4) screw holes provided on the top of the cylinder.
 - 7 Torque the B-3841-6 screw to 41 in-lb (4.6 N-m).
 - 8 Repeat steps 5.L.(2)(d)3 through 5.L.(2)(d)6 for the remaining three B-3837-0432 washers and B-3841-6 screws.
- (e) If the aircraft will be flown without the UID plate installed, the thin hex nut must be safety wired:
- 1 Install one (1) B-3837-0463 washer onto one (1) B-3841-5 screw.
 - 2 Install the washer and screw into any one of the four (4) screw holes provided on the top of the cylinder.
 - 3 Torque the B-3841-5 screw to 41 in-lb (4.6 N-m).
 - 4 Using 0.032 inch (0.81 mm) diameter stainless steel wire, safety wire the drilled thin hex nut to the one (1) B-3841-5 screw.

(This page is intentionally blank.)

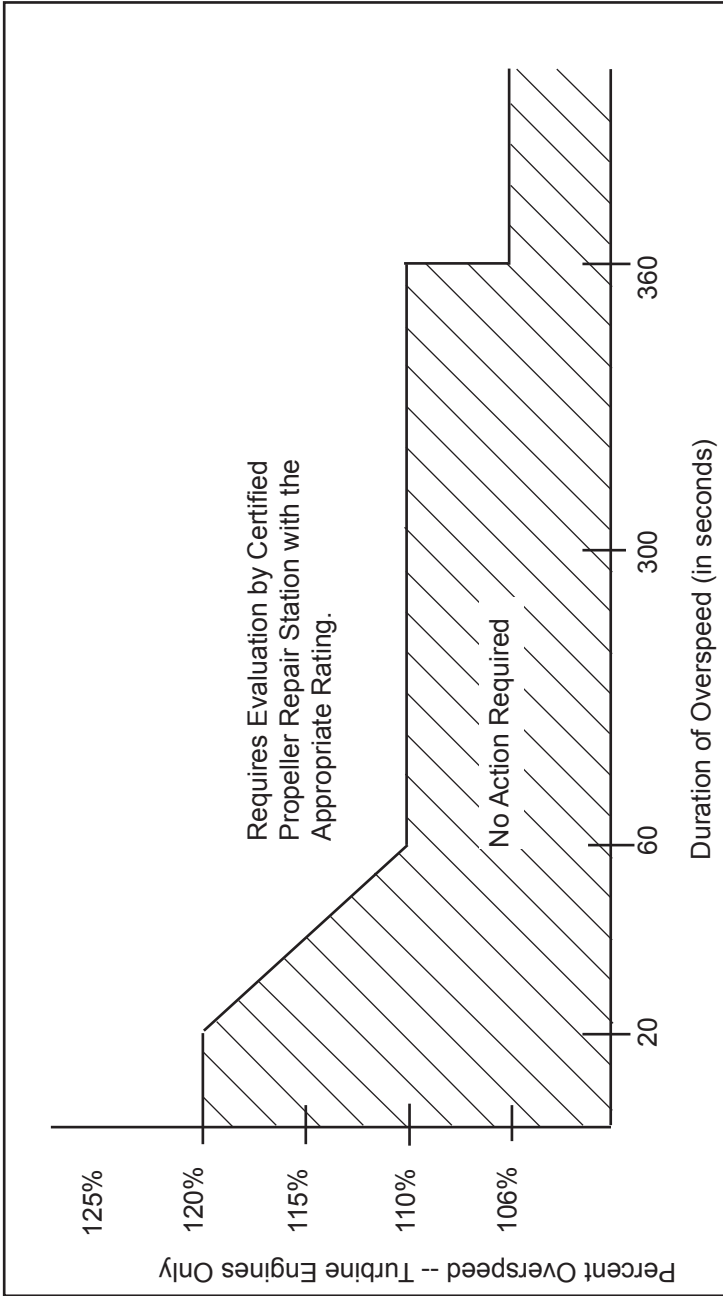

Turbine Engine Overspeed Limits
Figure 5-3

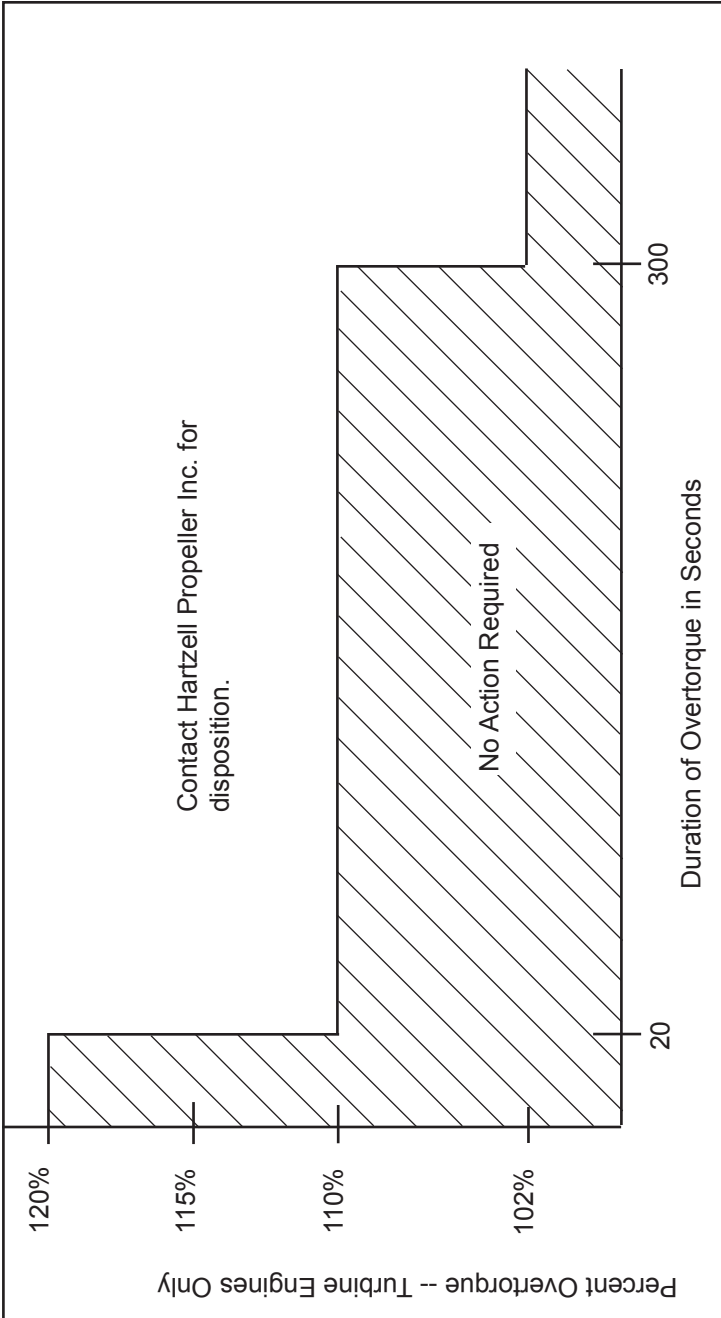

**Turbine Engine Overtorque Limits
Figure 5-4**

6. Special Inspections

CAUTION: INSTRUCTIONS AND PROCEDURES IN THIS SECTION MAY INVOLVE PROPELLER CRITICAL PARTS. REFER TO THE INTRODUCTION CHAPTER OF THIS MANUAL FOR INFORMATION ABOUT PROPELLER CRITICAL PARTS. REFER TO THE ILLUSTRATED PARTS LIST CHAPTER OF THE APPLICABLE OVERHAUL MANUAL(S) FOR THE IDENTIFICATION OF SPECIFIC PROPELLER CRITICAL PARTS.

A. Overspeed/Overtorque

An overspeed has occurred when the propeller RPM has exceeded the maximum RPM stated in the applicable Aircraft Type Certificate Data Sheet. An overtorque condition occurs when the engine load exceeds the limits established by the engine, propeller, or airframe manufacturer. The duration of time at overspeed/overtorque for a single event determines the corrective action that must be taken to ensure no damage to the propeller has occurred.

The criteria for determining the required action after an overspeed are based on many factors. The additional centrifugal forces that occur during overspeed are not the only concern. Some applications have sharp increases in vibratory stresses at RPMs above the maximum rated for the airframe/engine/propeller combination.

- (1) When a propeller installed on a turbine engine has an overspeed event, refer to the Turbine Engine Overspeed Limits (Figure 5-3) to determine the corrective action to be taken.

- (2) When a propeller installed on a turbine engine has an overtorque event, refer to the Turbine Engine Overtorque Limits (Figure 5-4) to determine the corrective action to be taken.
 - (a) Some aircraft installations have torque indicator values indicating 100 percent torque that are less than the maximum certified torque for the specific propeller model as listed in the propeller type certificate data sheet. If an overtorque occurs that requires propeller repair station evaluation, contact Hartzell Propeller Inc. Product Support to confirm actual overtorque percentage.
- (3) Make a log book entry to document the overspeed/ overtorque event.

B. Propeller Ground Idle Operating Restrictions

WARNING: STABILIZED GROUND OPERATION WITHIN THE PROPELLER RESTRICTED RPM RANGE CAN GENERATE HIGH PROPELLER STRESSES AND RESULT IN FATIGUE DAMAGE TO THE PROPELLER. THIS DAMAGE CAN LEAD TO A REDUCED PROPELLER FATIGUE LIFE, PROPELLER FAILURE, AND LOSS OF CONTROL OF THE AIRCRAFT. THE PROPELLER RESTRICTED RPM RANGE IS DEFINED IN THE AIRPLANE FLIGHT MANUAL.

- (1) General
 - (a) The information in this section does not apply to the HC-D3F-7 propeller model that is addressed in this manual.
 - (b) The information in this section is intended to emphasize the critical importance of correct propeller ground idle RPM on certain turboprop installations. It also defines the appropriate corrective action required when a propeller has been operated within this restricted RPM region.

- (c) If the propeller is operated within a restricted RPM range or below a minimum idle RPM restriction for an extended period of time, the propeller blades and hub can become unairworthy because of fatigue. A failed blade or hub has the potential to cause a catastrophic blade separation.
- (d) Four, five and six blade propellers operating on turbine engines can be sensitive to operation within restricted RPM ranges. These restricted ranges are usually in the lower RPM ranges, requiring that ground idle RPM be set above a critical minimum value.

Example:

Minimum propeller idle RPM listed in the AMM is	1180 RPM
Propeller idle is set at	1120 RPM
Propeller has operated with a RPM deviation of	60 RPM
Engine was rigged 2 months ago and has operated since it was rigged	75 hours

Figure 5-6 shows that with an RPM deviation of 60 RPM for 75 hours - the propeller assembly must be overhauled and engine rigging corrected before further flight.

**Example of an Evaluation of Ground Idle RPM Check
Figure 5-5**

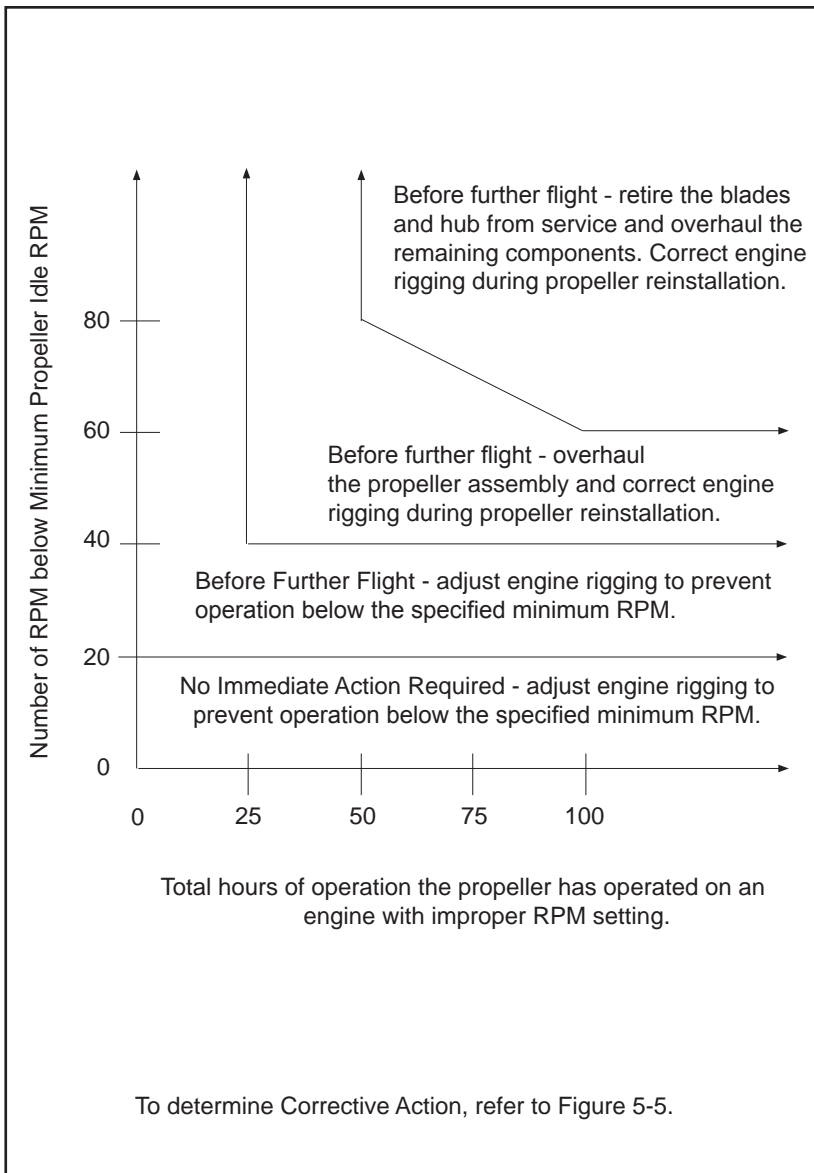

Corrective Action Required
Figure 5-6

- (e) This minimum propeller idle RPM operating restriction is the result of a specific vibratory resonant condition known as "reactionless mode". During operation in these conditions the flight crew cannot feel the resulting high propeller vibration. Ground operation at or near an RPM that can create a reactionless mode vibratory resonance can cause very high stresses in the propeller blades and the hub. These high stresses are more severe when operating in a tailing wind condition.
- (2) Periodic Ground Idle RPM Check
- (a) Perform the RPM check, especially following engine rigging/idle RPM adjustments.
 - (b) Refer to the Airplane Flight Manual or Airplane Flight Manual Supplement to determine if there are any propeller RPM restrictions or limitations.
 - (c) Check the accuracy of the tachometer. Refer to the section Tachometer Inspection in this chapter.
 - (d) Perform an engine run up and determine if the engine and/or propeller rigging permits operation of the propeller below the minimum specified propeller idle RPM.
 - (e) If the propeller cannot be operated below the minimum specified propeller idle RPM, no further action is required.
 - (f) If the propeller can be operated below the minimum specified propeller idle RPM:
 - 1 Refer to Figure 5-6 for corrective action. Refer to Figure 5-5 for help when using Figure 5-6.
 - 2 The corrective action is based on the amount the RPM is below the minimum propeller idle RPM and the total hours of operation the propeller has accumulated.
 - a Figure 5-6 applies to an aircraft that is operated in conventional service. "Hours of Operation" refers to the total number of hours the propeller is operated on an engine that has an improper RPM setting. It is not the number of hours the propeller is operated in a restricted range, which will be less than the total hours of operation.

(3) Corrective Action

- (a) The required corrective action is determined by both the amount and duration of RPM deviation.
- 1 A turboprop propeller with four or more blades may have a variety of operating restrictions and these different restrictions may have different operating margins.
 - 2 The greater the amount of the RPM deviation and the longer it is permitted to exist, the more severe the required corrective action.
 - 3 The corrective action may vary from no action required to scrapping of the blades and the hub.
 - 4 Refer to Figure 5-6 for the required corrective action.
 - 5 Contact Hartzell Propeller Inc. if further clarification is required.
 - 6 If a propeller restriction other than those described in Figure 5-6 has been violated, contact Hartzell Propeller Inc.
 - a The chart in Figure 5-6 applies only to operation below the minimum idle RPM.
 - b The chart in Figure 5-6 does not apply to other propeller restrictions that are above the minimum idle RPM.
 - 7 If the corrective action requires a propeller overhaul, overhaul the propeller in accordance with the applicable propeller overhaul manuals.
 - 8 If the corrective action requires that the blades and the hub be retired from service, retire these components from service in accordance with the Part Retirement Procedures chapter of Hartzell Propeller Inc. Standard Practices Manual 202A (61-01-02).
 - 9 A propeller hub or blade that has been retired from service because of a violation of the operating restrictions as specified in this section must not be reused on another aircraft application.

- 10 If the corrective action requires the correction of the propeller RPM setting, refer to the applicable installation and rigging instructions for the adjustment of engine torque, engine idle speed, and propeller RPM setting.
- 11 Contact Hartzell Propeller Inc. Product Support Department to report the findings.
- Hartzell Propeller Inc.
One Propeller Place
Piqua, Ohio 45356-2634 USA
Phone: 937.778.4379
Fax: 937.778.4391
techsupport@hartzellprop.com

I C. Lightning Strike

CAUTION: ALSO CONSULT ENGINE AND AIRFRAME MANUFACTURER'S MANUALS. THERE MAY BE ADDITIONAL REQUIREMENTS SUCH AS DE-ICE SYSTEM CHECKS AND ENGINE SYSTEM CHECKS TO PERFORM AFTER A PROPELLER LIGHTNING STRIKE.

(1) General

In the event of a propeller lightning strike, an inspection is required before further flight. It may be permissible to operate a propeller for an additional ten (10) hours of operation if the propeller is not severely damaged and meets the requirements in Procedure for Temporary Operation in this section. Regardless of the outcome of the initial inspection, the propeller must eventually be removed from the aircraft, disassembled, evaluated, and/or repaired by an authorized propeller repair station.

(2) Procedure for Temporary Operation

If temporary additional operation is desired before propeller removal and disassembly:

- (a) Remove spinner dome and perform visual inspection of propeller, spinner, and de-ice system for evidence of significant damage that would require repair before flight (such as broken de-ice wires or arcing damage to propeller hub).
- (b) If the only evident damage is minor arcing burns to the blades, then operation for ten (10) hours is acceptable before disassembly and inspection.
- (c) Perform a functional check of the propeller de-ice system (if installed) in accordance with aircraft maintenance manual procedures.
- (d) Regardless of the degree of damage, make a log book entry to document the lightning strike.
- (e) The propeller must be removed from the aircraft, disassembled, evaluated, and/or repaired by an authorized propeller repair station for flight beyond the temporary operation limits granted above.

D. Foreign Object Strike/Ground Strike

- (1) A foreign object strike/ground strike can include a broad spectrum of damage, from a minor stone nick to severe ground impact damage. A conservative approach in evaluating the damage is required because there may be hidden damage that is not readily apparent during an on-wing, visual inspection.
- (2) A foreign object strike is defined as:
 - (a) Any incident, whether or not the engine is operating, that requires repair to the propeller other than minor dressing of the blades. Examples of foreign object strike include situations where an aircraft is stationary and the landing gear collapses causing one or more blades to be significantly damaged, or where a hangar door (or other object) strikes the propeller blade. These cases should be handled as foreign object strikes because of potentially severe side loading on the propeller hub, blades and retention bearings.
 - (b) Any incident during engine operation in which the propeller impacts a solid object that causes a drop in revolutions per minute (RPM) and also requires structural repair of the propeller (incidents requiring only paint touch-up are not included). This is not restricted to propeller strikes against the ground.
 - (c) A sudden RPM drop while impacting water, tall grass, or similar yielding medium, where propeller blade damage is not normally incurred.

(3) Procedure

- (a) In the event of a foreign object strike, an inspection is required before further flight. If the inspection reveals one or more of the following indications, the propeller must be removed from the aircraft, disassembled, and overhauled in accordance with the applicable propeller and blade maintenance manuals.
- 1 A loose blade in the hub.
 - 2 Any noticeable or **suspected** damage to the pitch change mechanism.
 - 3 A bent blade (out of track or angle).
 - 4 Any blade diameter reduction.
 - 5 A bent, cracked, or failed engine shaft.
 - 6 Vibration during operation that was not present before the event.
- (b) Nicks, gouges, and scratches on blade surfaces or the leading and trailing edges must be removed before flight. Refer to Blade Repairs section in the Maintenance Practices chapter of this manual.
- (c) For engine mounted components (for example governors, pumps, and control units) manufactured by Hartzell Propeller Inc., if the foreign object strike resulted in a sudden stop of the engine, the unit must be disassembled and inspected in accordance with the applicable maintenance manual.
- (d) Regardless of the degree of damage, make a log book entry to document the foreign object strike incident and any corrective action(s) taken.

E. Fire Damage or Heat Damage

WARNING: HUBS ARE MANUFACTURED FROM HEAT TREATED FORGINGS AND ARE SHOT PEENED. BLADES ARE MANUFACTURED FROM HEAT TREATED FORGINGS AND ARE COMPRESSIVELY ROLLED AND SOMETIMES SHOT PEENED. EXPOSURE TO HIGH TEMPERATURES CAN DESTROY THE FATIGUE RESISTANCE BENEFITS OBTAINED FROM THESE PROCESSES.

On rare occasions propellers may be exposed to fire or heat damage, such as an engine or hangar fire. In the event of such an incident, an inspection by an authorized propeller repair station is required before further flight.

7. Long Term Storage

Parts shipped from the Hartzell Propeller Inc. factory are not shipped or packaged in a container which is designed for long term storage.

Long term storage procedures may be obtained by contacting a Hartzell Propeller Inc. distributor, or the Hartzell Propeller Inc. factory via the Product Support number listed in the Introduction chapter of this manual. Storage information is also detailed in Hartzell Propeller Inc. Manual 202A (61-01-02).

Information regarding the return of a propeller assembly to service after long term storage may be obtained by contacting a Hartzell Propeller Inc. distributor, or the Hartzell Propeller Inc. factory via the Product Support number listed in the Introduction chapter of this manual. This information is also detailed in Hartzell Propeller Inc. Manual 202A (61-01-02).

MAINTENANCE PRACTICES - CONTENTS

1. Cleaning	6-3
A. General Cleaning	6-3
B. Spinner Cleaning and Polishing	6-5
2. Lubrication	6-5
A. Lubrication Intervals	6-5
B. Lubrication Procedure	6-6
C. Approved Lubricants	6-9
3. Carbon Block Assemblies	6-10
A. Inspection	6-10
B. Replacement of the A-3026 Carbon Block Unit in the A-3044 Carbon Block Assembly	6-10
C. Installation of the A-3044 Carbon Block Assembly	6-12
4. Blade Repairs	6-12
A. Repair of Nicks and Gouges	6-13
B. Repair of Bent Blades	6-14
5. Painting After Repair	6-15
A. General	6-15
B. Painting of Aluminum Blades	6-16
6. Dynamic Balance	6-18
A. Overview	6-18
B. Inspection Procedures Before Balancing	6-19
C. Modifying Spinner Bulkhead to Accommodate Dynamic Balance Weights	6-20
D. Placement of Balance Weights for Dynamic Balance	6-20
7. Propeller Ice Protection Systems	6-22
A. Electric De-ice System	6-22
B. Anti-ice System	6-22

LIST OF FIGURES

Lubrication Fitting Figure 6-1 6-4

■ Repair Limitations..... Figure 6-2..... 6-11

LIST OF TABLES

Approved Touch-Up Paints..... Table 6-1 6-15

1. Cleaning

CAUTION 1: INSTRUCTIONS AND PROCEDURES IN THIS SECTION MAY INVOLVE PROPELLER CRITICAL PARTS. REFER TO THE INTRODUCTION CHAPTER OF THIS MANUAL FOR INFORMATION ABOUT PROPELLER CRITICAL PARTS. REFER TO THE ILLUSTRATED PARTS LIST CHAPTER OF THE APPLICABLE OVERHAUL MANUAL(S) FOR THE IDENTIFICATION OF SPECIFIC PROPELLER CRITICAL PARTS.

CAUTION 2: DO NOT USE PRESSURE WASHING EQUIPMENT TO CLEAN THE PROPELLER OR CONTROL COMPONENTS. PRESSURE WASHING CAN FORCE WATER AND/OR CLEANING SOLVENTS PAST SEALS, AND CAN LEAD TO INTERNAL CORROSION OF PROPELLER COMPONENTS.

A. General Cleaning

CAUTION 1: DO NOT CLEAN PROPELLER WITH CAUSTIC OR ACIDIC SOAP SOLUTIONS. IRREPARABLE CORROSION OF PROPELLER COMPONENTS MAY OCCUR.

CAUTION 2: WHEN CLEANING THE PROPELLER, DO NOT PERMIT SOAP OR SOLVENT SOLUTIONS TO RUN OR SPLASH INTO THE HUB AREA.

(1) Wash propeller with a noncorrosive soap solution.

CAUTION: DO NOT USE ANY SOLVENT DURING CLEANING THAT COULD SOFTEN OR DESTROY THE BOND BETWEEN CHEMICALLY ATTACHED PARTS.

(2) To remove grease or oil from propeller surfaces, apply Stoddard Solvent or equivalent to a clean cloth and wipe the part clean.

(3) Thoroughly rinse in water and permit to dry.

TI-00102

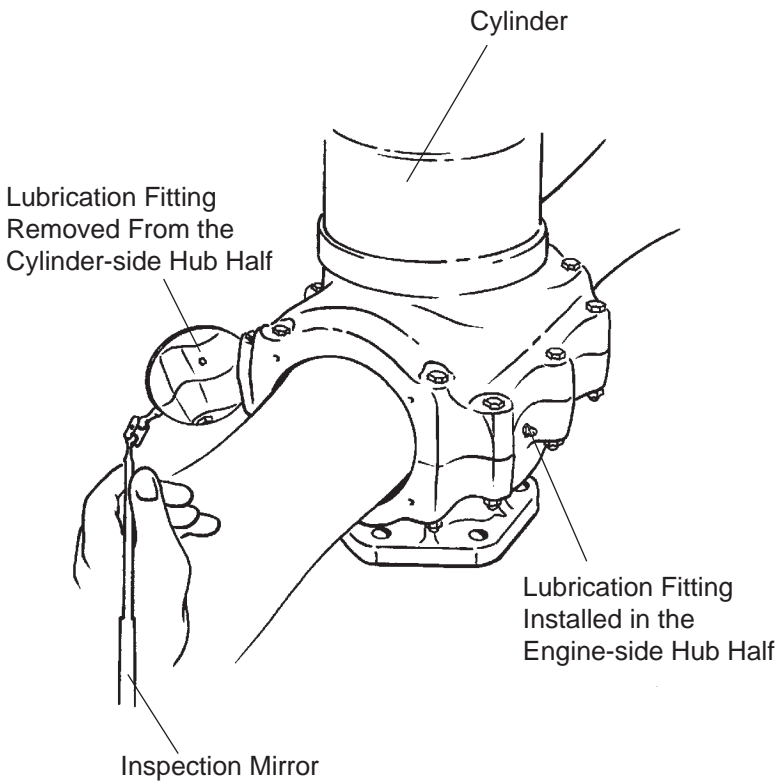

NOTE: A 2-blade propeller is shown for illustration purposes only.

Lubrication Fitting
Figure 6-1

B. Spinner Cleaning and Polishing

- (1) Clean the spinner using the General Cleaning procedures in this section.
- (2) Polish the dome, if necessary, with an automotive type aluminum polish.

2. Lubrication

CAUTION: INSTRUCTIONS AND PROCEDURES IN THIS SECTION MAY INVOLVE PROPELLER CRITICAL PARTS. REFER TO THE INTRODUCTION CHAPTER OF THIS MANUAL FOR INFORMATION ABOUT PROPELLER CRITICAL PARTS. REFER TO THE ILLUSTRATED PARTS LIST CHAPTER OF THE APPLICABLE OVERHAUL MANUAL(S) FOR THE IDENTIFICATION OF SPECIFIC PROPELLER CRITICAL PARTS.

A. Lubrication Intervals

- (1) The propeller is to be lubricated at intervals not to exceed 400 hours or (12) calendar months, whichever occurs first.
 - (a) The HC-E5()-3() propeller installed on Piaggio P-180 is to be lubricated at 150 hour intervals or at twelve (12) calendar months, whichever occurs first, all other applications is to be lubricated at 400 hour intervals.
 - (b) If annual operation is significantly less than 400 hours, calendar lubrication intervals should be reduced to six months.
 - (c) If the aircraft is operated or stored under adverse atmospheric conditions, e.g., high humidity, salt air, calendar lubrication intervals should be reduced to six months.
- (2) Owners of high use aircraft may wish to extend their lubrication intervals. Lubrication interval may be gradually extended after evaluation of previous propeller overhauls with regard to bearing wear and internal corrosion.

(3) Hartzell Propeller Inc. recommends that new or newly overhauled propellers be lubricated after the first one or two hours of operation because centrifugal loads will pack and redistribute grease, which may result in a propeller imbalance. Redistribution of grease may also result in voids in the blade bearing area where moisture can collect.

- (a) Purchasers of new aircraft should check the propeller logbook to verify whether the propeller was lubricated by the manufacturer during flight testing. If it was not lubricated, the propeller should be serviced at the earliest convenience.

B. Lubrication Procedure

CAUTION: FOLLOW LUBRICATION PROCEDURES CORRECTLY TO MAINTAIN ACCURATE BALANCE OF THE PROPELLER ASSEMBLY.

- (1) Remove the propeller spinner.
- (2) Refer to Figure 6-1. Each blade socket has two lubrication fittings. Remove the lubrication fitting caps from the lubrication fittings. Remove the lubrication fittings from either the cylinder side or the engine side of the hub assembly.

NOTE: It is preferable to apply grease to the fitting located nearest the leading edge of the blade on a tractor installation and nearest the trailing edge on a pusher installation. Lubricating at this location reduces the possibility of grease bypassing the bearing area and entering the hub cavity.

- (a) A 45 degree lubrication fitting (Hartzell Propeller Inc P/N C-6349) may be installed on the engine-side or cylinder-side of the propeller in any location where a straight lubrication fitting (Hartzell Propeller Inc P/N A-279) was originally installed. The 45 degree lubrication fitting simplifies lubrication.
- (b) The lubrication fittings installed on the engine-side or cylinder-side must be either all straight (Hartzell Propeller Inc P/N A-279) or all 45 degree (Hartzell Propeller Inc. P/N C-6349).

- (3) Using a piece of safety wire, loosen any blockage or hardened grease at the threaded holes where the lubrication fitting was removed.

WARNING: WHEN MIXING AEROSHELL GREASES 5 AND 6, AEROSHELL GREASE 5 MUST BE INDICATED ON THE LABEL (HARTZELL PROPELLER INC. P/N A-3594) AND THE AIRCRAFT MUST BE PLACARDED TO INDICATE THAT FLIGHT IS PROHIBITED IF THE OUTSIDE AIR TEMPERATURE IS LESS THAN -40°F (-40°C).

CAUTION: USE HARTZELL PROPELLER INC. APPROVED GREASE ONLY. EXCEPT IN THE CASE OF AEROSHELL GREASES 5 AND 6, DO NOT MIX DIFFERENT SPECIFICATIONS AND/OR BRANDS OF GREASE.

- (4) Aeroshell greases 5 and 6 both have a mineral oil base and have the same thickening agent; therefore, mixing of these two greases is acceptable in Hartzell propellers.
- (5) A label (Hartzell Propeller Inc. P/N A-3494) is normally applied to the propeller to indicate the type of grease previously used. Refer to Figure 6-2.
- (a) This grease type should be used during re-lubrication unless the propeller has been disassembled and the old grease removed.
 - (b) It is NOT possible to purge old grease through lubrication fittings.
 - (c) To completely replace one grease with another, the propeller must be disassembled in accordance with the applicable overhaul manual.

CAUTION 1: OVER LUBRICATING AN ALUMINUM HUB PROPELLER MAY CAUSE THE GREASE TO ENTER THE HUB CAVITY, LEADING TO EXCESSIVE VIBRATION AND/OR SLUGGISH OPERATION. THE PROPELLER MUST THEN BE DISASSEMBLED TO REMOVE THIS GREASE.

CAUTION 2: IF A PNEUMATIC GREASE GUN IS USED, EXTRA CARE MUST BE TAKEN TO AVOID EXCESSIVE PRESSURE BUILDUP.

CAUTION 3: GREASE MUST BE APPLIED TO ALL BLADES OF A PROPELLER ASSEMBLY AT THE TIME OF LUBRICATION.

- (6) Pump 1 fl. oz. (30 ml) grease into each engine-side lubrication fitting, or until grease emerges from the hole where the lubrication fitting was removed - whichever occurs first.

NOTE: 1 fl. oz. (30 ml) is approximately 6 pumps with a hand-operated grease gun.

- (7) Reinstall the removed lubrication fittings.

(a) A 45 degree lubrication fitting, Hartzell Propeller Inc. part number C-6349, may be installed on the engine-side or cylinder-side of the propeller aluminum hub in any location where a straight lubrication fitting, Hartzell Propeller Inc. part number A-279, was originally installed.

- 1 The lubrication fittings installed on the engine-side of the aluminum hub must be either all straight, Hartzell Propeller Inc. part number A-279, or all 45 degree, Hartzell Propeller Inc. part number C-6349.
- 2 The lubrication fittings installed on the cylinder-side of the aluminum hub must be either all straight, Hartzell Propeller Inc. part number A-279, or all 45 degree, Hartzell Propeller Inc. part number C-6349.

(b) Tighten the fittings until snug.

(c) Make sure that the ball of each lubrication fitting is properly seated.

(8) Reinstall a lubrication fitting cap on each lubrication fitting.

C. Approved Lubricants

The following lubricants are approved for use in Hartzell Aluminum hub propellers:

Aeroshell 6 - Recommended "all purpose" grease. Used in most new production propellers since 1989. Higher leakage/oil separation than Aeroshell 5 at higher temperatures.

Aeroshell 5 - Good high temperature qualities, very little oil separation or leakage. Cannot be used in temperatures colder than -40°F (-40°C). Aircraft serviced with this grease must be placarded to indicate that flight is prohibited if the outside air temperature is less than -40°F (-40°C).

Aeroshell 7 - Good low temperature grease, but high leakage/oil separation at higher temperatures. This grease has been associated with sporadic problems involving seal swelling.

Aeroshell 22 - Qualities similar to Aeroshell 7. Used in Piaggio P-180 and the Grob Egret applications.

Royco 22CF - Not widely used. Qualities similar to Aeroshell 22.

3. Carbon Block Assemblies**A. Inspection**

The clearance between the yoke pin and the corresponding linkage (beta lever bushing) can become too close because of a buildup of plating and foreign particles between the two pieces. This can cause a binding action, resulting in excessive wear to the carbon block, low stop collar, and beta linkage.

CAUTION: INSTRUCTIONS AND PROCEDURES IN THIS SECTION MAY INVOLVE PROPELLER CRITICAL PARTS. REFER TO THE INTRODUCTION CHAPTER OF THIS MANUAL FOR INFORMATION ABOUT PROPELLER CRITICAL PARTS. REFER TO THE ILLUSTRATED PARTS LIST CHAPTER OF THE APPLICABLE OVERHAUL MANUAL(S) FOR THE IDENTIFICATION OF SPECIFIC PROPELLER CRITICAL PARTS.

- (1) Inspect the beta lever and carbon block interface for free movement. If there is binding, do the following:
 - (a) Disconnect the beta linkage and remove the carbon block assemblies from the beta ring.
 - (b) Using an abrasive pad, lightly polish the yoke pin to provide adequate clearance and eliminate binding.
 - (c) Reinstall the carbon block assembly into the beta ring.
 - (d) Install, adjust and safety the beta linkage per the airframe manufacturer's instructions.

B. Replacement of the A-3026 Carbon Block Unit in the A-3044 Carbon Block Assembly

Replace an A-3026 carbon block unit if the side clearance between the beta ring and carbon block exceeds 0.010 inch (0.25 mm).

- (1) Remove the cotter pin from the end of the clevis pin.
- (2) Slide the pin from the assembly and remove and discard the carbon block unit.
- (3) Inspect the yoke for wear or cracks. Replace the yoke if necessary.

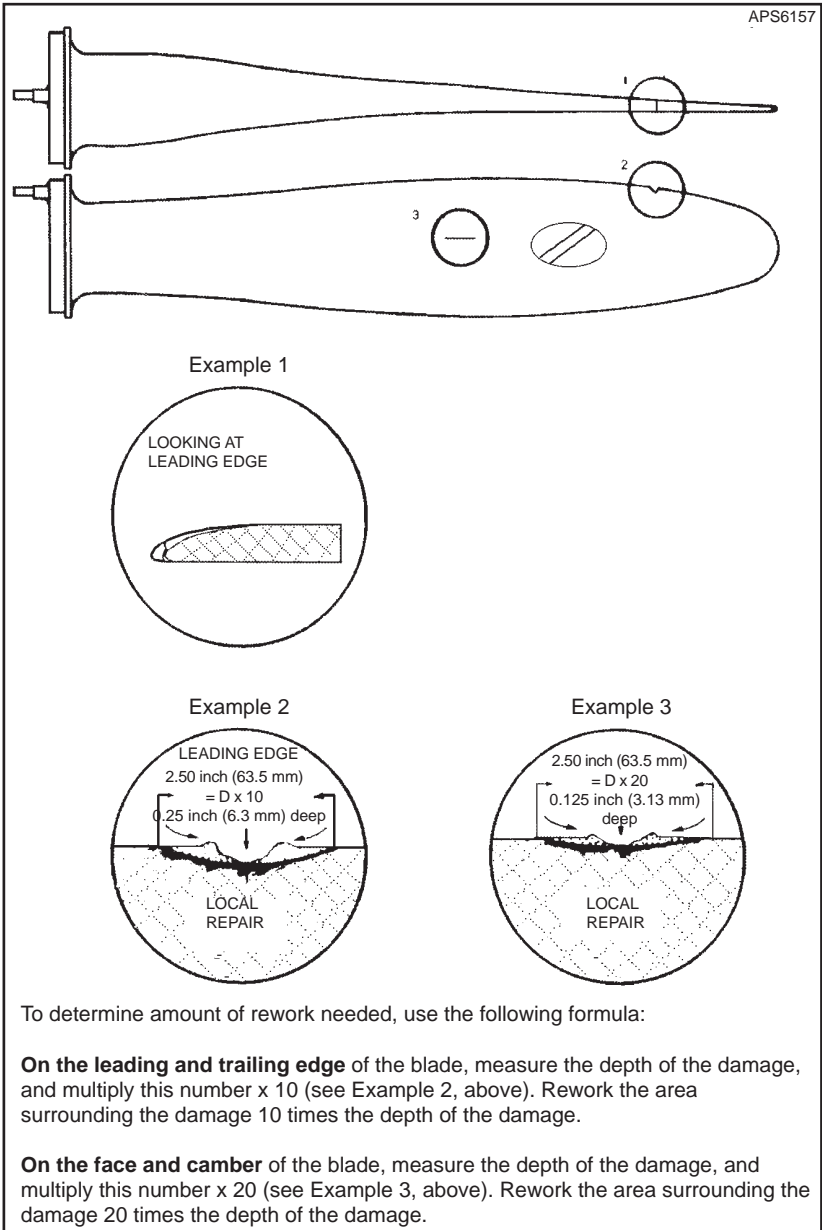

Repair Limitations
Figure 6-2

- (4) Install a new carbon block unit and slide a new clevis pin into place.
- (5) Secure the clevis pin with a T-head cotter pin. Refer to Figure 3-8.
- (6) Refit the carbon block. Refer to Figure 3-7.
 - (a) Establish the required clearance by sanding the sides of the carbon block as needed.

C. Installation of the A-3044 Carbon Block Assembly

Refer to Installation and Removal Chapter of this manual for installation instructions.

4. Blade Repairs

WARNING: ALL NICKS, GOUGES, OR SCRATCHES OF ANY SIZE CAN CREATE A STRESS RISER THAT COULD POTENTIALLY LEAD TO BLADE CRACKING. ALL DAMAGE SHOULD BE VISUALLY EXAMINED CAREFULLY BEFORE FLIGHT FOR THE PRESENCE OF CRACKS OR OTHER ABNORMALITIES.

CAUTION: BLADES THAT HAVE BEEN PREVIOUSLY REPAIRED OR OVERHAULED MAY HAVE BEEN DIMENSIONALLY REDUCED. BEFORE REPAIRING SIGNIFICANT DAMAGE OR MAKING REPAIRS ON BLADES THAT ARE APPROACHING SERVICEABLE LIMITS, CONTACT AN APPROPRIATELY LICENSED PROPELLER REPAIR FACILITY OR THE HARTZELL PROPELLER INC. PRODUCT SUPPORT DEPARTMENT FOR BLADE DIMENSIONAL LIMITS.

Nicks, gouges, and scratches on blade surfaces or on the leading or trailing edges of the blade must be removed before flight. Field repair of small nicks and scratches may be performed by qualified personnel in accordance with FAA Advisory Circular 43.13-1B, as well as the procedures specified below. Normal blade lead edge erosion (sand-blasted appearance) is acceptable, and does not require removal before further flight.

A. Repair of Nicks and Gouges

Local repairs may be made using files, electrical or air powered equipment. Emery cloth, scotch brite, and crocus cloth are to be used for final finishing. Refer to Figure 6-2.

CAUTION 1: REWORK THAT INVOLVES COLD WORKING THE METAL, RESULTING IN CONCEALMENT OF A DAMAGED AREA, IS NOT ACCEPTABLE. A STRESS CONCENTRATION MAY EXIST THAT CAN RESULT IN A BLADE FAILURE.

CAUTION 2: BLADES THAT HAVE BEEN SHOT PEENED (AS INDICATED BY A "PEBBLE GRAIN" SURFACE) THAT HAVE DAMAGE IN THE SHOT PEENED AREAS IN EXCESS OF 0.015 INCH (0.38 mm) DEEP ON THE FACE OR CAMBER OR 0.250 INCH (6.35 mm) ON THE LEADING OR TRAILING EDGES MUST BE REMOVED FROM SERVICE, AND THE REWORKED AREA SHOT PEENED BEFORE FURTHER FLIGHT. SHOT PEENING OF AN ALUMINUM BLADE MUST BE ACCOMPLISHED BY AN APPROPRIATELY LICENSED REPAIR FACILITY IN ACCORDANCE WITH HARTZELL PROPELLER INC. ALUMINUM BLADE MANUAL 133C (61-13-33).

- (1) Repairs to the leading or trailing edge are to be accomplished by removing material from the bottom of the damaged area. Remove material from this point out to both sides of the damage, providing a smooth, faired depression that maintains the general original airfoil shape.
- (2) Repairs to the blade face or camber should be made in the same manner as above. Repairs that form a continuous line across the blade section (chordwise) are not permitted.

- (3) The area of repair should be determined as follows:
Leading and trailing edge damage: Depth of nick x 10.
Face and camber: Depth of nick x 20. Refer to Figure 6-2.

NOTE: Leading edge includes the first 10 percent of chord from the leading edge. The trailing edge consists of the last 20 percent of chord adjacent to the trailing edge.

- (4) After filing or sanding of the damaged area, the area must then be polished, first with emery cloth or Scotch Brite Pad , and finally with crocus cloth to remove any traces of filing.
- (5) Inspect the repaired area with a 10X magnifying glass.
- (a) Make sure that indications of the damage, file marks, or coarse surface finish do not remain.
- (6) If inspections shows any remaining blade damage, repeat steps 3.A.(4) through 3.A.(5)(a) until no damage remains.
- (a) Dye penetrant inspection is recommended in accordance with Hartzell Propeller Inc. Manual 202A (61-01-02).
- (7) Treat the repaired area to prevent corrosion.
- (a) Apply chemical conversion coating and approved paint to the repaired area before returning the blade to service. Refer to the section "Painting After Repair" in this chapter.

B. Repair of Bent Blades

CAUTION: DO NOT ATTEMPT TO "PRE-STRAIGHTEN" A BLADE BEFORE DELIVERY TO AN APPROPRIATELY LICENSED PROPELLER REPAIR FACILITY. THIS WILL CAUSE THE BLADE TO BE SCRAPPED BY THE REPAIR FACILITY.

- (1) Repair of a bent blade or blades is considered a major repair. This type of repair must be accomplished by an appropriately licensed propeller repair facility, and only within approved guidelines.

5. Painting After Repair

CAUTION: INSTRUCTIONS AND PROCEDURES IN THIS SECTION MAY INVOLVE PROPELLER CRITICAL PARTS. REFER TO THE INTRODUCTION CHAPTER OF THIS MANUAL FOR INFORMATION ABOUT PROPELLER CRITICAL PARTS. REFER TO THE ILLUSTRATED PARTS LIST CHAPTER OF THE APPLICABLE OVERHAUL MANUAL(S) FOR THE IDENTIFICATION OF SPECIFIC PROPELLER CRITICAL PARTS.

A. General

- (1) A propeller blade is painted with a durable specialized coating that is resistant to abrasion. If this coating becomes eroded, it is necessary to repaint the blades to provide proper corrosion and erosion protection. Painting must be performed at an appropriately licensed propeller repair facility in accordance with Hartzell Standard Practices Manual 202A (61-01-02).
- (2) It is permitted to perform a blade touch-up with aerosol paint in accordance with the procedures in Painting of Aluminum Blades in this chapter.
- (3) Refer to Table 6-1 for paints approved for blade touch-up.

Vendor	Color	Vendor P/N	Hartzell P/N
Tempo	Epoxy Black	A-150	n/a
Tempo	Epoxy Gray	A-151	n/a
Tempo	Epoxy White (tip stripe)	A-152	n/a
Tempo	Epoxy Red (tip stripe)	A-153	n/a
Tempo	Epoxy Yellow (tip stripe)	A-154	n/a
Sherwin-Williams	Black	F75KXB9958-4311	A-6741-145-1
Sherwin-Williams	Gray	F75KXA10445-4311	A-6741-146-1
Sherwin-Williams	White (tip stripe)	F75KXW10309-4311	A-6741-147-1
Sherwin-Williams	Red (tip stripe)	F75KXR12320-4311	A-6741-149-1
Sherwin-Williams	Yellow (tip stripe)	F75KXY11841-4311	A-6741-150-1
Sherwin-Williams	Silver	F75KXS13564-4311	A-6741-190-1

**Approved Touch-Up Paints
Table 6-1**

- (4) The paint manufacturers may be contacted by using the following information:

Tempo Products Co.

A plasti-kote Company
1000 Lake Road
Medina, OH 44256
Tel: 800.321.6300
Fax: 216.349.4241
Cage Code: 07708

Sherwin Williams Co.

2390 Arbor Boulevard
Dayton, Ohio
Tel: 937.298.8691
Fax: 937.298.3820
Cage Code: 0W199

B. Painting of Aluminum Blades

WARNING: CLEANING AGENTS (ACETONE, #700 LACQUER THINNER, AND MEK), ARE FLAMMABLE AND TOXIC TO THE SKIN, EYES AND RESPIRATORY TRACT. SKIN AND EYE PROTECTION IS REQUIRED. AVOID PROLONGED CONTACT. USE IN WELL VENTILATED AREA.

CAUTION: ANY REFINISHING PROCEDURE CAN ALTER PROPELLER BALANCE. PROPELLERS THAT ARE OUT OF BALANCE MAY EXPERIENCE EXCESSIVE VIBRATIONS WHILE IN OPERATION.

- (1) Using acetone, #700 lacquer thinner, or MEK, wipe the surface of the blade to remove any contaminants.
- (2) Feather the existing coatings away from the eroded or repaired area with 120 to 180 grit sandpaper.

NOTE: Paint erosion is typically very similar on all blades in a propeller assembly. If one blade has more extensive damage, e.g., in the tip area, all the blades should be sanded in the tip area to replicate the repair of the most severely damaged blade tip. This practice is essential in maintaining balance after refinishing.

- (3) Use acetone, #700 lacquer thinner, or MEK to wipe the surface of the blade. Permit the solvent to evaporate.

- (4) Before refinishing the blades, apply a corrosion preventive coating to the bare aluminum surface. Oakite 31, Chromicote L-25, or Alodine 1201 are approved chemical conversion coatings. Apply these coatings in accordance with the directions provided by the product manufacturer.
- (5) Apply masking material to the de-ice boot and tip stripes, as needed.

WARNING: FINISH COATINGS ARE FLAMMABLE AND TOXIC TO THE SKIN, EYES, AND RESPIRATORY TRACT. SKIN AND EYE PROTECTION IS REQUIRED. AVOID PROLONGED CONTACT. USE IN WELL VENTILATED AREA.

CAUTION: APPLY FINISH COATING ONLY TO THE DEGREE REQUIRED TO UNIFORMLY COVER THE REPAIR/EROSION. AVOID EXCESSIVE PAINT BUILD-UP ALONG THE TRAILING EDGE TO AVOID CHANGING BLADE PROFILE.

- (6) Apply sufficient finish coating to achieve 2 to 4 mils thickness when dry. Re-coat before 30 minutes, or after 48 hours. If the paint is permitted to dry longer than four (4) hours it must be lightly sanded before another coat is applied.
- (7) Remove the masking from the tip stripes and re-mask to permit tip stripe refinishing if required.
- (8) Apply sufficient tip stripe coating to achieve 2 to 4 mils thickness when dry. Re-coat before 30 minutes, or after 48 hours. If the paint is permitted to dry longer than four (4) hours it must be lightly sanded before another coat is applied.
- (9) Remove tape immediately.
- (10) Optionally, perform dynamic balancing in accordance with the procedures and limitations specified in Dynamic Balance section of this chapter.

6. Dynamic Balance

WARNING: WHEN USING REFLECTIVE TAPE FOR DYNAMIC BALANCING, DO NOT APPLY THE TAPE ON EXPOSED BARE METAL OF A BLADE. THIS WILL CAUSE MOISTURE TO COLLECT UNDER THE TAPE AND CAUSE CORROSION THAT CAN PERMANENTLY DAMAGE THE BLADE.

CAUTION: INSTRUCTIONS AND PROCEDURES IN THIS SECTION MAY INVOLVE PROPELLER CRITICAL PARTS. REFER TO THE INTRODUCTION CHAPTER OF THIS MANUAL FOR INFORMATION ABOUT PROPELLER CRITICAL PARTS. REFER TO THE ILLUSTRATED PARTS LIST CHAPTER OF THE APPLICABLE OVERHAUL MANUAL(S) FOR THE IDENTIFICATION OF SPECIFIC PROPELLER CRITICAL PARTS.

A. Overview

Dynamic balance is recommended to reduce vibrations that may be caused by a rotating system (propeller and engine) imbalance. Dynamic balancing can help prolong the life of the propeller, engine, airframe, and avionics.

- (1) Static balancing is required when an overhaul or major repair is performed at a propeller overhaul facility.

NOTE: If static balancing is not accomplished before dynamic balancing, the propeller may be so severely unbalanced that dynamic balance may not be achieved.

- (2) Dynamic balance is accomplished by using an accurate means of measuring the amount and location of the dynamic imbalance.
- (3) The number of balance weights installed must not exceed the limits specified in this chapter.

- (4) Follow the dynamic balance equipment manufacturer's instructions for dynamic balance, in addition to the specifications of this section.

NOTE: The Static and Dynamic Balance chapter of Hartzell Standard Practices Manual 202A (61-01-02) also contains information about weight placement and balancing.

B. Inspection Procedures Before Balancing

- (1) Visually inspect the propeller assembly before dynamic balancing.

NOTE: The first run-up of a new or overhauled propeller assembly may leave a small amount of grease on the blades and inner surface of the spinner dome.

- (a) Using a mild solvent, completely remove any grease on the blades or inner surface of the spinner dome.
 - (b) Visually examine each propeller blade assembly for evidence of grease leakage.
 - (c) Visually examine the inner surface of the spinner dome for evidence of grease leakage.
- (2) If there is no evidence of grease leakage, lubricate the propeller in accordance with the Maintenance Practices chapter in this manual. If grease leakage is evident, determine the location of the leak and correct before re-lubricating the propeller and before dynamic balancing.
 - (3) Before dynamic balance make a record the number and location of all balance weights.

C. Modifying Spinner Bulkhead to Accommodate Dynamic Balance Weights

CAUTION: ALL HOLE/BALANCE WEIGHT LOCATIONS MUST TAKE INTO CONSIDERATION, AND MUST AVOID, ANY POSSIBILITY OF INTERFERING WITH THE ADJACENT AIRFRAME, DE-ICE AND ENGINE COMPONENTS.

- (1) It is recommended that the balance weights be placed in a radial location on aluminum spinner bulkheads that have not been previously drilled.
- (2) The radial location must be outboard of the de-ice slip ring or bulkhead doubler and inboard of the bend where the bulkhead creates the flange to attach the spinner dome.
- (3) Twelve equally spaced locations for weight attachment are recommended.
- (4) Install nut plates (10-32 thread) of the type used to attach the spinner dome. This will permit convenient balance weight attachment on the engine side of the bulkhead.
- (5) Alternatively, drilling holes for use with the AN3-() type bolts with self-locking nuts is acceptable.
 - (a) Chadwick-Helmuth Manual AW-9511-2, "The Smooth Propeller", specifies several generic bulkhead rework procedures. These are acceptable providing they comply with the conditions specified herein.

D. Placement of Balance Weights for Dynamic Balance

- (1) The preferred method of attachment of dynamic balance weights is to add the weights to the spinner bulkhead.

NOTE: Many spinner bulkheads have factory installed self-locking nut plates provided for this purpose.
- (2) If the location of static balance weights has not been altered, subsequent removal of the dynamic balance weights will return the propeller to its original static balance condition.
- (3) Use only stainless or plated steel washers as dynamic balance weights on the spinner bulkhead.

- (4) Do not exceed a maximum weight per location of 1.0 oz. (28 g).

NOTE: This is approximately equal to six AN970 style washers (0.188 inch ID, 0.875 inch OD, 0.063 inch thickness) (4.78 mm ID, 22.23 mm OD, 1.60 mm thickness).

- (5) Install weights using aircraft quality #10-32 or AN-3() type screws or bolts.
- (6) Balance weight screws attached to the spinner bulkhead must protrude through the self-locking nuts or nut plates a minimum of one thread and a maximum of four threads.
- (7) Unless otherwise specified by the engine or airframe manufacturer, Hartzell recommends that the propeller be dynamically balanced to a reading of 0.2 IPS, or less.

CAUTION: IF REFLECTIVE TAPE IS USED FOR DYNAMIC BALANCING, REMOVE THE TAPE IMMEDIATELY UPON COMPLETION. TAPE THAT REMAINS ON THE BLADE WILL CAUSE MOISTURE TO COLLECT UNDER THE TAPE AND CAUSE CORROSION THAT CAN PERMANENTLY DAMAGE THE BLADE.

- (8) If reflective tape is used for dynamic balancing, remove the tape immediately after balancing is completed.
- (9) Make a record in the logbook of the number and location of dynamic balance weights and static balance weights, if they have been reconfigured.

7. Propeller Ice Protection Systems**A. Electric De-ice System**

- (1) Consult the Pilot Operating Handbook (including all supplements) regarding flight into conditions of known icing. The aircraft may not be certificated for flight in known icing conditions, even though propeller de-ice equipment is installed.
- (2) Refer to the Anti-ice and De-ice Systems chapter of this manual for functional tests of the de-ice system.

B. Anti-ice System

- (1) Consult the Pilot Operating Handbook (including all supplements) regarding flight into conditions of known icing. The aircraft may not be certificated for flight in known icing conditions, even though propeller anti-ice equipment is installed.
- (2) Refer to the Anti-ice and De-ice Systems chapter of this manual for functional tests of the anti-ice system.

ANTI-ICE AND DE-ICE SYSTEMS - CONTENTS

1. Introduction.....	7-3
A. Propeller De-ice System	7-3
B. Anti-ice System	7-3
2. System Description.....	7-4
A. De-ice System.....	7-4
B. Anti-ice System	7-5
3. De-ice System Functional Tests	7-5
4. Anti-ice System Functional Tests.....	7-5
5. De-ice and Anti-ice System Inspections	7-6
A. De-ice System Inspections	7-6
B. Anti-ice System Inspections.....	7-6
6. De-ice and Anti-ice System Troubleshooting.....	7-7
A. De-ice System Troubleshooting	7-7
B. Anti-ice System Troubleshooting	7-7

(This page is intentionally blank.)

1. Introduction**A. Propeller De-ice System**

- (1) A propeller de-ice system is a system that removes ice after it forms on the propeller blades. A de-ice system uses electrical heating elements to melt the ice layer next to the blades, permitting the ice to be thrown from the blade by centrifugal force. The de-ice system timer controls the application of current to the blades, alternately heating them and permitting them to cool.
- (2) System components include a timer or cycling unit, electrical slip ring(s), brush block assembly, and blade mounted de-ice boots.

B. Anti-ice System

- (1) A propeller anti-ice system is a system that prevents formation of ice on propeller surfaces. An anti-ice system dispenses a fluid that mixes with, and reduces the freezing point of, moisture on the propeller blades. The mixture may then flow off the blades before it forms ice.
- (2) System components include a fluid tank, pump, slinger ring, and blade mounted fluid anti-icing boots.

2. System Description**A. De-ice System**

NOTE: Because of the many differences in various de-ice systems, the following description is general in nature. Consult the airframe manufacturer's manual for a description of your specific de-ice system and controls.

The de-ice system is controlled by the pilot via a cockpit control switch. This switch applies power to the de-ice system, which will operate as long as the switch is in the ON position. Depending upon the system, another set of cockpit controls may be available. One of these controls is a mode selector, which permits the pilot to select two cycling speeds, for heavy or light icing conditions. Some systems on twin engine aircraft have a switch which provides a full de-ice mode, which allows the pilot to de-ice both propellers simultaneously. This switch may only be used for short periods and is used when ice builds up on the propeller before the system is turned on.

- (1) An ammeter, which indicates current drawn by the system, is normally located near the de-ice system switches. This ammeter may indicate total system load, or a separate ammeter may be supplied for each propeller.
- (2) A timer, which is turned off and on by the cockpit control, is used to sequence the de-ice system. This timer turns the de-ice system on and off in proper sequence, controlling the heating interval for each propeller blade and making sure of even de-icing.
- (3) A brush block mounted on the engine immediately behind the propeller supplies electric current to the de-ice boot on each propeller blade via a slip ring. The slip ring is normally mounted on the spinner bulkhead.
- (4) When the pilot places the de-ice system cockpit control switch in the ON position, the system timer begins to operate. As the timer sequences, power is delivered to a power relay. The power relay delivers high current through the brush block and slip ring to the de-ice boot.

B. Anti-ice System

- (1) The anti-ice system is controlled by the pilot via a cockpit mounted rheostat. This rheostat operates a pump that pumps anti-ice fluid from the tank at a controlled rate.
- (2) The anti-ice fluid is delivered through a filter, a check valve, and then through tubing to a slinger ring located at the rear of the spinner bulkhead. The anti-ice fluid is dispensed into the rotating slinger ring, which holds the fluid in a curved channel by centrifugal force. The fluid then flows out of the slinger ring through feed tubes which are welded to the slinger ring, and then out onto the blade anti-icing boots.
- (3) The blade anti-icing boots are ridged rubber sheets that are glued to the leading edge of the blades. The ridges in the anti-icing boots direct the fluid out onto the blades and permit for an even distribution of the anti-ice fluid across the blades.

3. De-ice System Functional Tests

A. Functional tests of the de-ice system should be performed in accordance with the following Hartzell Manuals, which are available on the Hartzell Propeller website at www.hartzellprop.com:

- (1) Hartzell Manual No. 181 (30-60-81) - Propeller Ice Protection System Component Maintenance Manual
- (2) Hartzell Manual No. 182 (61-12-82) - Propeller Electrical De-ice Boot Removal and Installation Manual

4. Anti-ice System Functional Tests

A. Operational Checks of the anti-ice system should be performed in accordance with the following Hartzell Manuals, which are available on the Hartzell Propeller website at www.hartzellprop.com:

- (1) Hartzell Manual 181 (30-60-81) - Propeller Ice Protection System Component Maintenance Manual
- (2) Hartzell Manual 183 (61-12-83) - Propeller Anti-icing Boot Removal and Installation Manual

5. De-ice and Anti-ice System Inspections

The inspections are made on a regular basis, either before flight, during the 100 hour inspection, or if a problem is noted. Possible corrections to problems discovered during inspections, additional inspections, and limits are detailed in the following Hartzell Propeller Inc. manuals, which are available on the Hartzell Propeller Inc. website at www.hartzellprop.com:

A. De-ice System Inspections

(1) Perform inspections in accordance with the following Hartzell Propeller Inc. manuals, which are available on the Hartzell Propeller Inc. website at www.hartzellprop.com:

(a) Hartzell Propeller Inc. Manual No. 181 (30-60-81) - Propeller Ice Protection System Component Maintenance Manual

(b) Hartzell Propeller Inc. Manual No. 182 (61-12-82) - Propeller Electrical De-ice Boot Removal and Installation Manual

B. Anti-ice System Inspections

(1) Perform inspections in accordance with the following Hartzell Propeller Inc. manuals, which are available on the Hartzell Propeller Inc. website at www.hartzellprop.com:

(a) Hartzell Manual 181 (30-60-81) - Propeller Ice Protection System Component Maintenance Manual

(b) Hartzell Manual 183 (61-12-83) - Propeller Anti-icing Boot Removal and Installation Manual

6. De-ice and Anti-ice System Troubleshooting**A. De-ice System Troubleshooting**

(1) Perform troubleshooting in accordance with the following Hartzell Propeller Inc. manuals, which are available on the Hartzell Propeller Inc. website at www.hartzellprop.com:

(a) Hartzell Propeller Inc. Manual No. 181 (30-60-81) - Propeller Ice Protection Component Maintenance Manual

(b) Hartzell Propeller Inc. Manual No. 182 (61-12-82) - Propeller Electrical De-ice Boot Removal and Installation Manual

B. Anti-ice System Troubleshooting

(1) Perform troubleshooting in accordance with the following Hartzell Propeller Inc. manuals, which are available on the Hartzell Propeller Inc. website at www.hartzellprop.com:

(a) Hartzell Propeller Inc. Manual No. 181 (30-60-81) - Propeller Ice Protection System Component Maintenance Manual

(b) Hartzell Propeller Inc. Manual No. 183 (61-12-83) - Propeller Anti-icing Boot Removal and Installation Manual

(This page is intentionally blank.)

I

RECORDS - CONTENTS

1. Introduction..... 8-3

2. Record Keeping..... 8-3

 A. Information to be Recorded 8-3

(This page is intentionally blank.)

1. Introduction

- A. Federal Aviation Regulations require that a record be kept of any repairs, adjustments, maintenance, or required inspections performed on a propeller or propeller system.
- B. This chapter provides a method for maintaining these records. It also provides a location for recording information which can aid the service technician in maintaining the propeller system.

2. Record Keeping**A. Information to be Recorded**

- (1) Information which is required to be recorded is listed in Part 43 of the U.S. Federal Aviation Regulations.
- (2) The log book may also be used to record:
 - (a) Propeller position (on aircraft)
 - (b) Propeller model.
 - (c) Propeller serial number
 - (d) Blade design number
 - (e) Blade serial numbers
 - (f) Spinner assembly part number
 - (g) Propeller pitch range
 - (h) Aircraft information (aircraft type, model, serial number and registration number)

(This page is intentionally blank.)