

Manual No. 139

61-00-39

Revision 13

June 2015

Propeller Owner's Manual and Logbook

Series: HC-B3()()-2()
HC-B3()()-3()
HC-B3()()-5()
HC-B3TF-7()
HC-B4()()-3()
HC-B4()()-5()
HC-B5M()-2()
HC-B5M()-3()
HC-B5M()-5()
HC-A3(V,MV)F-7()

Steel Hub Turbine Propellers with Aluminum Blades

Hartzell Propeller Inc.

One Propeller Place

Piqua, OH 45356-2634 U.S.A.

Ph: 937-778-4200 (Hartzell Propeller Inc.)

Ph: 937-778-4379 (Product Support)

Product Support Fax: 937-778-4391

As a fellow pilot, I urge you to read this Manual thoroughly. It contains a wealth of information about your new propeller.

The propeller is among the most reliable components of your airplane. It is also among the most critical to flight safety. It therefore deserves the care and maintenance called for in this Manual. Please give it your attention, especially the section dealing with Inspections and Checks.

Thank you for choosing a Hartzell propeller. Properly maintained it will give you many years of reliable service.



Jim Brown

Chairman, Hartzell Propeller Inc.

WARNING

People who fly should recognize that various types of risks are involved; and they should take all precautions to minimize them, since they cannot be eliminated entirely. The propeller is a vital component of the aircraft. A mechanical failure of the propeller could cause a forced landing or create vibrations sufficiently severe to damage the aircraft, possibly causing it to become uncontrollable.

Propellers are subject to constant vibration stresses from the engine and airstream, which are added to high bending and centrifugal stresses.

Before a propeller is certified as being safe to operate on an airplane, an adequate margin of safety must be demonstrated. Even though every precaution is taken in the design and manufacture of a propeller, history has revealed rare instances of failures, particularly of the fatigue type.

It is essential that the propeller is properly maintained according to the recommended service procedures and a close watch is exercised to detect impending problems before they become serious. Any grease or oil leakage, unusual vibration, or unusual operation should be investigated and repaired, as it could be a warning that something serious is wrong.

For operators of uncertified or experimental aircraft an even greater level of vigilance is required in the maintenance and inspection of the propeller. Experimental installations often use propeller-engine combinations that have not been tested and approved. In these cases, the stress on the propeller and, therefore, its safety margin is unknown. Failure could be as severe as loss of a propeller or propeller blades and cause loss of propeller control and/or loss of aircraft control.

Hartzell Propeller Inc. follows FAA regulations for propeller certification on certificated aircraft. Experimental aircraft may operate with unapproved engines or propellers or engine modifications to increase horsepower, such as unapproved crankshaft damper configurations or high compression pistons. These issues affect the vibration output of the engine and the stress levels on the propeller. Significant propeller life reduction and failure are real possibilities.

Frequent inspections are strongly recommended if operating with a non-certificated installation; however, these inspections may not guarantee propeller reliability, as a failing device may be hidden from the view of the inspector. Propeller overhaul is strongly recommended to accomplish periodic internal inspection.

Visually inspect metal blades for cracks. Inspect hubs, with particular emphasis on each blade arm for cracks. Eddy current equipment is recommended for hub inspection, since cracks are usually not apparent.

(This page is intentionally blank.)



REVISION 13 HIGHLIGHTS

Revision 13, dated June 2015, incorporates the following:

- COVER
 - Revised to match the manual revision
- REVISION HIGHLIGHTS
 - Revised to match the manual revision
- LIST OF EFFECTIVE PAGES
 - Revised to match the manual revision
- TABLE OF CONTENTS
 - Revised to match the manual revision
- INTRODUCTION
 - Revised to add the use of safety cable
 - Revised the section, "Reference Publications"
 - Made other language/format changes
- INSTALLATION AND REMOVAL
 - Revised to add the use of safety cable, where applicable
 - Revised the section, "Installing HC-B(3, 4)()W-3() Propeller on the Aircraft Engine" to include compliance with GE Aviation Service Bulletin H80-100-72-00019 on Thrush aircraft models S2R-H80 or S2RHG-H80
 - Made other language/format changes
- INSPECTION AND CHECK
 - Revised the illustration, "Turbine Engine Overtorque Limits"
- MAINTENANCE PRACTICES
 - Revised the section, "Carbon Block Assemblies"

(This page is intentionally blank.)



REVISION HIGHLIGHTS**1. Introduction****A. General**

- (1) This is a list of current revisions that have been issued against this manual. Please compare it to the RECORD OF REVISIONS page to make sure that all revisions have been added to the manual.

B. Components

- (1) Revision No. indicates the revisions incorporated in this manual.
- (2) Issue Date is the date of the revision.
- (3) Comments indicates the level of the revision.
 - (a) New Issue is a new manual distribution. The manual is distributed in its entirety. All the page revision dates are the same and no change bars are used.
 - (b) Reissue is a revision to an existing manual that includes major content and/or major format changes. The manual is distributed in its entirety. All the page revision dates are the same and no change bars are used.
 - (c) Major Revision is a revision to an existing manual that includes major content or minor content changes over a large portion of the manual. The manual is distributed in its entirety. All the page revision dates are the same, but change bars are used to indicate the changes incorporated in the latest revision of the manual.
 - (d) Minor Revision is a revision to an existing manual that includes minor content changes to the manual. Only the revised pages of the manual are distributed. Each page retains the date and the change bars associated with the last revision to that page.

<u>Revision No.</u>	<u>Issue Date</u>	<u>Comments</u>
Revision 5	Oct/99	Reissue
Revision 6	Mar/01	Minor Revision
Revision 7	Oct/02	Minor Revision
Revision 8	Dec/06	Minor Revision
Revision 9	Aug/09	Minor Revision
Revision 10	Jun/11	Minor Revision
Revision 11	Jul/12	Minor Revision
Revision 12	Mar/13	Minor Revision
Revision 13	Jun/15	Minor Revision

RECORD OF REVISIONS

Rev. No. Issue Date Date Inserted Inserted By

Rev. No.	Issue Date	Date Inserted	Inserted By

RECORD OF TEMPORARY REVISIONS

TR No.	Issue Date	Date Inserted	Inserted By	Date Removed	Removed By
TR-001	Nov/03	Nov/03	HPI	12/06	HPI
TR-002	Nov/03	Nov/03	HPI	4/04	HPI
TR-003	Dec/03	Dec/03	HPI	12/06	HPI
TR-004	Apr/04	Apr/04	HPI	12/06	HPI
TR-005	Oct/04	Oct/04	HPI	12/06	HPI
TR-006	Mar/06	Mar/06	HPI	12/06	HPI

RECORD OF TEMPORARY REVISIONS

TR No.	Issue Date	Date Inserted	Inserted By	Date Removed	Removed By

SERVICE DOCUMENTS LIST

CAUTION 1: DO NOT USE OBSOLETE OR OUTDATED INFORMATION. PERFORM ALL INSPECTIONS OR WORK IN ACCORDANCE WITH THE MOST RECENT REVISION OF A SERVICE DOCUMENT. INFORMATION CONTAINED IN A SERVICE DOCUMENT MAY BE SIGNIFICANTLY CHANGED FROM EARLIER REVISIONS. FAILURE TO COMPLY WITH INFORMATION CONTAINED IN A SERVICE DOCUMENT OR THE USE OF OBSOLETE INFORMATION MAY CREATE AN UNSAFE CONDITION THAT MAY RESULT IN DEATH, SERIOUS BODILY INJURY, AND/OR SUBSTANTIAL PROPERTY DAMAGE.

CAUTION 2: THE INFORMATION FOR THE DOCUMENTS LISTED INDICATES THE REVISION LEVEL AND DATE AT THE TIME THAT THE DOCUMENT WAS INITIALLY INCORPORATED INTO THIS MANUAL. INFORMATION CONTAINED IN A SERVICE DOCUMENT MAY BE SIGNIFICANTLY CHANGED FROM EARLIER REVISIONS. REFER TO THE APPLICABLE SERVICE DOCUMENT INDEX FOR THE MOST RECENT REVISION LEVEL OF THE SERVICE DOCUMENT.

Service Document Number	Incorporation Rev/Date
Service Alerts:	
SA 57	Oct/02
Service Bulletins:	
HC-SB-61-143B	Oct/02
HC-SB-61-181A, Rev. 4	Rev. 11 Jul/12
HC-SB-61-275	Aug/09

SERVICE DOCUMENTS LIST

Service Document Number	Incorporation Rev/Date
Service Letters:	
HC-SL-61-217	Oct/99
HC-SL-61-248	Rev. 11, Jul/12
HC-SL-61-254	Aug/09
HC-SL-61-324	Rev. 11, Jul/12

AIRWORTHINESS LIMITATIONS

The Airworthiness Limitations section is FAA approved and specifies maintenance required under 14 CFR §§ 43.16 and 91.403 of the Federal Aviation Regulations unless an alternative program has been FAA approved.

FAA APPROVED

by: Michael Davis date: 6/7/11



Manager, Chicago Aircraft Certification
Office,
ACE-115C
Federal Aviation Administration

Rev. No.	Description of Revision
9	Adds airworthiness limitation information from Hartzell Overhaul Manuals 118F (61-10-18) and 132A (61-10-32)
10	For blade life limit, revised the blade model designation to include (N) version for HC-B3TN-3(B,H) and HC-B4TN-5 (C,F) propellers

AIRWORTHINESS LIMITATIONS

1. The Airworthiness Limitations in this chapter have been relocated from Hartzell Overhaul Manuals 118F (61-10-18) and 132A (61-10-32) to this manual.
2. Replacement Time (Life Limits)
 - A. The FAA establishes specific life limits for certain component parts, as well as the entire propeller. Such limits require replacement of the identified parts after a specified number of hours of use.
 - B. The following data summarize all current information about Hartzell life limited parts as related to propeller models affected by this manual. These parts are not life limited on other installations; however, time accumulated toward life limit accrues when first operated on aircraft/engine/propeller combinations listed and continues regardless of subsequent installations (which may or may not be life limited).
 - (1) Blade models that incorporate ice protection components do not affect the blade life limit. Example: The (B,K) letter designation in blade model T10178(B,K) indicates that ice protection components may be installed. If ice protection components are installed, the blade life limit still applies.
 - C. The following list specifies life limits for **blades only** that are on FAA Type Certified Aircraft. Blades listed are life limited only on the specified applications.

FAA APPROVED

by: Michael Davis date: 6/7/11

for

Manager, Chicago Aircraft Certification Office,
ACE-115C

Federal Aviation Administration

(1) FAA Type Certified Aircraft - Blade Life Limits

Aircraft/Engine/Propeller	Blade Life Limit
Aircraft: Beech T34C,T34C-1 Engine: Pratt & Whitney - PT6A-25, -25A Propeller: HC-B3TN-3(B,H)/T10173(N)-11R	9,634 hours
Aircraft: CASA 212 Engine: Allied Signal - TPE331-5-251C Propeller: HC-B4TN-5(C,F)L/LT10282(N)+4	31,000 hours
Aircraft: Fairchild Swearingen SA226TC Metro IIA Engine: Allied Signal - TPE331-10UA, -501G or 511G Propeller: HC-B3TN-5(C,E,M)/T10282(H)(N)	9,000 hours*
Aircraft: Mitsubishi MU-2's Engine: Allied Signal - TPE-331-(5,10)-() Propeller: HC-B4TN-5()L/LT10282N(S)-5.3R	10, 000 hours
Aircraft: Pilatus PC-7 Engine: Pratt and Whitney - PT6A-25,-25A Propeller: HC-B3TN-2()/T10173C(N)-8	4,240 hours** to 9,795 hours
Aircraft: Pilatus PC-7 modified by Sierra Industries Engine: Pratt and Whitney - PT6A-25C Propeller: HC-B3TN-2/T10178(N)-8R	3,000 hours

FAA APPROVED

by: Michael Owens date: 6/7/11



Manager, Chicago Aircraft Certification Office,
ACE-115C
Federal Aviation Administration

- * Fairchild Swearingen Metro IIA, Serial Numbers TC398 and subsequent, model T10282()() propeller blades are life limited when operated above 12,500 pounds gross weight and must be retired after 9,000 hours of operation. The life limit begins once the blades are operated above 12,500 pounds gross weight and continues regardless of subsequent operating weight.

For those blades on which the total accumulated time in operation on an aircraft with a gross weight exceeding 12,500 pounds cannot be confirmed, the following formula will be used to establish an assumed time:

Months from date of STC incorporation X 180 = total assumed time on subject blades.

- ** Pilatus PC-7 propeller blades must be retired from service in accordance with the following schedule:
 - (a) Aircraft on which Power-On-Spin, Inertia Coupled Entry, and Snap Roll flight maneuvers are prohibited must be retired from service when 9795 flight hours have been acquired.
 - (b) Aircraft on which Power-On-Spin and Inertia Coupled Entry flight maneuvers are prohibited must be retired from service when 4240 flight hours have been acquired.
 - (c) Any aircraft, once operated with Snap Roll maneuvers permitted, must be retired from service upon acquiring 4240 flight hours.

FAA APPROVED

by: Michael J. Jones

date: 6/17/11



Manager, Chicago Aircraft Certification Office,
ACE-115C
Federal Aviation Administration

D. The following list specifies life limits for **blades only** that are on an aircraft *without* FAA Type Certificate. Blades listed are life limited only on the specified applications.

(1) Aircraft *Without* FAA Type Certificate - Blade Life Limits

Aircraft/Engine/Propeller	Blade Life Limit
Aircraft: Embraer EMB-312 Engine: Pratt & Whitney - PT6A-25C Propeller: HC-B3TN-3(C,D)/T10178(B,K)-8R	12,000 hours
Aircraft: NDN-1T Firecracker Engine: Pratt & Whitney - PT6A-25A Propeller: HC-B3TN-3(B,C)/T10173(B,K)-17	45,000 hours
Aircraft: North American Rockwell OV-10A Engine: Garrett T76-G-418M, -419M Propeller: HC-B4MN-5B(L)/(L)M9990N	20,900 hours
Aircraft: North American Rockwell OV-10D Engine: Garrett T76-G-420, -421 Propeller: HC-B4MN-5B(L)/(L)M9990N	20,900 hours
Aircraft: Antonov AN-38-100 (MTOW 9500 kg) Engine: Garrett - TPE-331-14GR Propeller: HC-B5MA-5A/M11276NK-3	22,000 hours
Aircraft: Antonov AN-38-100 (MTOW 9900 kg) Engine: Garrett TPE-331-14GR Propeller: HC-B5MA-5A/M11276NCK-3	11,300 hours
Aircraft: Embraer EMB-314 PT6A-68C Engine: Pratt & Whitney Propeller: HC-B5MA-2/M9128NS(K)	9,960 hours

FAA APPROVED

by:



date:

6/7/11



Manager, Chicago Aircraft Certification Office,
ACE-115C
Federal Aviation Administration

E. The following list specifies life limits for **hubs only**. Hub units listed are life limited only on the specified applications.

(1) FAA Type Certified Aircraft - **Hub** Life Limits

NONE

(2) Aircraft *Without* FAA Type Certificate - **Hub** Life Limits

Aircraft/Engine/Propeller	Hub Life Limit
Aircraft: Embraer EMB-314 Engine: Pratt & Whitney - PT6A-68C Propeller: HC-B5MA-2/M9128NS(K)	19,589 hours

F. The following list specifies life limits for **clamps only**. Clamp assemblies listed are life limited only on the specified applications.

(1) Propeller Models on FAA Type Certified Aircraft

NONE

(2) Propeller Models on Aircraft *without* FAA Type Certificate

Aircraft/Engine/Propeller	Clamp Life Limit
Aircraft: Embraer EMB-314 Engine: Pratt & Whitney - PT6A-68C Propeller: HC-B5MA-2/M9128NS(K)	19,589 hours

FAA APPROVED

by: Michael Deane date: 6/7/11

for

Manager, Chicago Aircraft Certification Office,
ACE-115C

Federal Aviation Administration

G. The following list specifies life limits for **pitch change rod part number C-1169-1 only**. Pitch change rods listed are life limited only on the specified applications.

(1) Propeller Models on FAA Type Certified Aircraft

Aircraft/Engine/Propeller	Pitch Change Rod Life Limit
Aircraft: Air Tractor AT-802(A) Engine: Honeywell - TPE331-14GR() Propeller: HC-B5MA-5H/M11693NS	6,026 hours

(2) Propeller Models on Aircraft *without* FAA Type Certificate

Aircraft/Engine/Propeller	Pitch Change Rod Life Limit
Aircraft: Marsh/Grumman S2 Engine: Honeywell - TPE331-14() Propeller: HC-B5MP-5/M11276(N)S(K)	6,026 hours
Aircraft: Marsh/Grumman S2F3 Engine: Honeywell - TPE331-14() Propeller: HC-B5MA-5H/M11692NS(K)	6,026 hours

FAA APPROVED

by:

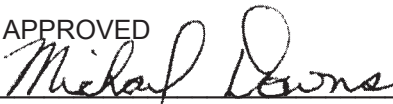

date:

6/7/11



Manager, Chicago Aircraft Certification Office,
ACE-115C

Federal Aviation Administration

H. The following list specifies life limits for **pitch change rod part number C-1169-2 only**. Pitch change rods listed are life limited only on the specified applications.

(1) Propeller Models on FAA Type Certified Aircraft

NONE

(2) Propeller Models on Aircraft *without* FAA Type Certificate

Aircraft/Engine/Propeller	Pitch Change Rod Life Limit
Aircraft: Antonov AN-38-100 Engine: Honeywell - TPE331-14() Propeller: HC-B5MA-5A/M11276N(C)K-3	12,053 hours

2. Periodic Inspections

A. The HC-B3TN-3UL/LT10173N-21R propeller installed on Advanced Aerodynamics & Structures model 450 "Jetcruzer" is required to have repetitive blade inspection for erosion and/or corrosion at intervals not to exceed 24 months or 600 hours of operation, whichever occurs first. Inspection methods and procedures are described in Hartzell Service Bulletin HC-SB-61-181A.

FAA APPROVED

by:



date:

6/7/11



Manager, Chicago Aircraft Certification Office,
ACE-115C
Federal Aviation Administration

LIST OF EFFECTIVE PAGES

Chapter	Page	Revision	Date
■ Cover	Cover and Inside Cover	Rev. 13	Jun/15
Message	1 thru 4	Rev. 6	Mar/01
■ Revision Highlights	5 thru 8	Rev. 13	Jun/15
Record of Revisions	9 and 10	Rev. 6	Mar/01
Record of Temporary Revisions	11 and 12	Rev. 6	Mar/01
Service Documents List	13 and 14	Rev. 11	Jul/12
Airworthiness Limitations	15 thru 22	Rev. 10	Jun/11
List of Effective Pages	23 and 24	Rev. 13	Jun/15
Table of Contents	25 and 26	Rev. 12	Mar/13
Table of Contents	27	Rev. 13	Jun/15
Table of Contents	28 thru 31	Rev. 12	Mar/13
Table of Contents	32	Rev. 13	Jun/15
Table of Contents	33 and 34	Rev. 12	Mar/13
Introduction	1-1 thru 1-5	Rev. 12	Mar/13
■ Introduction	1-6 thru 1-13	Rev. 13	Jun/15
■ Introduction	1-14 thru 1-16	Rev. 11	Jul/12
Description and Operation	2-1	Rev. 12	Mar/13
Description and Operation	2-2	Rev. 11	Jul/12
Description and Operation	2-3	Rev. 10	Jun/11
Description and Operation	2-4	Rev. 7	Oct/02
Description and Operation	2-5	Rev. 11	Jul/12
Description and Operation	2-6 thru 2-19	Rev. 7	Oct/02
Description and Operation	2-20	Rev. 11	Jul/12
Description and Operation	2-21 thru 2-27	Rev. 7	Oct/02
Description and Operation	2-28 and 2-29	Rev. 11	Jul/12
Description and Operation	2-30 and 2-31	Rev. 10	Jun/11
Description and Operation	2-32 thru 2-35	Rev. 7	Oct/02
Description and Operation	2-36 thru 2-38	Rev. 12	Mar/13
■ Installation and Removal	3-1 thru 3-4	Rev. 13	Jun/15
Installation and Removal	3-5	Rev. 7	Oct/02
Installation and Removal	3-6 thru 3-10	Rev. 11	Jul/12
Installation and Removal	3-11	Rev. 8	Dec/06
■ Installation and Removal	3-12	Rev. 13	Jun/15

LIST OF EFFECTIVE PAGES

Chapter	Page	Revision	Date
Installation and Removal	3-13 thru 3-16	Rev. 11	Jul/12
Installation and Removal	3-17 and 3-18	Rev. 13	Jun/15
Installation and Removal	3-19	Rev. 11	Jul/12
Installation and Removal	3-20 thru 3-23	Rev. 13	Jun/15
Installation and Removal	3-24 and 3-25	Rev. 11	Jul/12
Installation and Removal	3-26 thru 3-29	Rev. 13	Jun/15
Installation and Removal	3-30	Rev. 11	Jul/12
Installation and Removal	3-31 thru 3-70	Rev. 13	Jun/15
Testing and Troubleshooting	4-1 and 4-2	Rev. 12	Mar/13
Testing and Troubleshooting	4-3	Rev. 7	Oct/02
Testing and Troubleshooting	4-4	Rev. 12	Mar/13
Testing and Troubleshooting	4-5 thru 4-10	Rev. 7	Oct/02
Testing and Troubleshooting	4-11 and 4-12	Rev. 10	Jun/11
Inspection and Check	5-1	Rev. 12	Mar/13
Inspection and Check	5-2 thru 5-19	Rev. 11	Jul/12
Inspection and Check	5-20 and 5-21	Rev. 12	Mar/13
Inspection and Check	5-22	Rev. 11	Jul/12
Inspection and Check	5-23	Rev. 13	Jun/15
Inspection and Check	5-24 thru 5-34	Rev. 11	Jul/12
Maintenance Practices	6-1 and 6-2	Rev. 12	Mar/13
Maintenance Practices	6-3	Rev. 11	Jul/12
Maintenance Practices	6-4	Rev. 6	Mar/01
Maintenance Practices	6-5 thru 6-8	Rev. 11	Jul/12
Maintenance Practices	6-9	Rev. 13	Jun/15
Maintenance Practices	6-10	Rev. 11	Jul/12
Maintenance Practices	6-11	Rev. 12	Mar/13
Maintenance Practices	6-12 thru 6-22	Rev. 11	Jul/12
Maintenance Practices	6-23 and 6-24	Rev. 12	Mar/13
Anti-ice and De-ice Systems	7-1 thru 7-8	Rev. 12	Mar/13
Records	8-1 thru 8-4	Rev. 5	Oct/99

<u>CONTENTS</u>	<u>Page</u>
MESSAGE.....	1
REVISION HIGHLIGHTS	5
RECORD OF REVISIONS	9
RECORD OF TEMPORARY REVISIONS.....	11
SERVICE DOCUMENT LIST.....	13
AIRWORTHINESS LIMITATIONS	15
LIST OF EFFECTIVE PAGES	23
TABLE OF CONTENTS.....	25
INTRODUCTION.....	1-1
1. Purpose.....	1-3
2. Airworthiness Limitations	1-3
3. Airframe or Engine Modifications	1-4
4. Restrictions and Placards	1-4
5. General	1-5
A. Personnel Requirements	1-5
B. Maintenance Practices	1-5
C. Continued Airworthiness	1-8
D. Propeller Critical Parts	1-8
6. Reference Publications	1-9
7. Definitions	1-10
8. Abbreviations	1-14
9. Hartzell Propeller Inc. Product Support.....	1-15
10. Warranty Service.....	1-15
11. Hartzell Propeller Inc. Recommended Facilities	1-16

CONTENTS

Page

DESCRIPTION AND OPERATION	2-1
1. Functional Description of Constant Speed Propeller Types.....	2-5
A. Feathering Propellers HC-B(3,5)() ()-2().....	2-5
B. Feathering and Reversing Propellers HC-B(3,4,5)() ()-3() Series (External Beta System).....	2-9
C. Feathering and Reversing Propellers HC-B(3,4,5)() ()-5() Series (Internal Beta System).....	2-17
D. Feathering and Reversing Propellers HC-()3() ()-7() Series (Beta Valve System).....	2-24
2. Model Designation	2-28
A. Steel Hub Propeller Model Identification.....	2-28
B. Aluminum Blade Model Identification.....	2-31
3. Governors	2-33
A. Theory of Operation.....	2-33
4. Propeller Ice Protection Systems	2-36
A. Propeller Anti-ice System.....	2-36
B. Propeller De-ice System	2-37
INSTALLATION AND REMOVAL	3-1
1. Tools, Consumables, and Expendables.....	3-3
A. Tooling	3-3
B. Consumables.....	3-4
C. Expendables	3-4
2. Pre-Installation	3-5
A. Inspection of Shipping Package	3-5
B. Uncrating	3-5
C. Inspection after Shipment.....	3-5
D. Reassembly of a Propeller Disassembled for Shipment.....	3-5

	<u>Page</u>
3. Propeller Assembly Installation	3-6
A. Precautions	3-6
B. Installing HC-B(3, 5)()(-2() Propeller on the Aircraft Engine	3-7
C. Installing HC-B(3,4,5)()(A,N,P)-3() Propeller on the Aircraft Engine	3-14
D. Installing HC-B(3,4)()W-3() Propeller on the Aircraft Engine	3-20
E. Installing HC-B(3,4)()(-5() Propeller, with a One-piece Spinner Mounting Plate, on the Aircraft Engine	3-29
F. Installing HC-B(3,4,5)()(-5() Propeller, with a Two-piece Spinner Mounting Plate, on the Aircraft Engine	3-35
G. Installing HC-()3()(-7() Propeller on the Allison Engine	3-40
4. Spinner Dome Installation	3-50
5. Post-Installation Checks	3-50
6. Spinner Dome Removal	3-51
7. Propeller Assembly Removal	3-52
A. Removal of HC-B(3,5)()(-2() Propellers	3-52
B. Removal of HC-B(3,4,5)()(A,N,P)-3() Propellers	3-55
C. Removal of HC-B(3,4)()W-3() Propellers	3-59
D. Removal of HC-B(3,4,5)()(-5() Propellers	3-62
E. Removal of HC-()3()(-7() Propellers	3-65
F. Removal of Beta Valve Assembly for HC-()3()(-7() Propellers	3-68

CONTENTS

Page

TESTING AND TROUBLESHOOTING	4-1
1. Operational Tests	4-3
A. Initial Run-Up	4-3
B. Post-Run Check	4-3
C. Maximum RPM (Static) Hydraulic Low Pitch Stop Check	4-3
D. Feathering Pitch Stop Adjustment	4-4
E. Start Lock Unit Adjustment	4-4
F. Propeller Ice Protection System	4-4
2. Troubleshooting	4-4
A. Hunting and Surging	4-4
B. Engine Speed Varies with Airspeed	4-5
C. Loss of Propeller Control	4-6
D. Failure to Feather (or feathers slowly)	4-6
E. Failure to Unfeather	4-7
F. Start Lock Units Fail to Latch on Shutdown (-2, -5 and some -3 Models)	4-7
G. Vibration	4-8
H. Propeller Overspeed	4-9
I. Propeller Underspeed	4-9
J. Oil or Grease Leakage	4-10
INSPECTION AND CHECKS	5-1
1. Pre-Flight Checks	5-3
2. Post-Flight Checks	5-5
3. Operational Checks	5-6
4. Required Periodic Inspections and Maintenance	5-7
A. Periodic Inspections	5-7
B. Periodic Maintenance	5-8
C. Compliance Inspections	5-8
D. Airworthiness Limitations	5-11
E. Overhaul Periods	5-12

	<u>CONTENTS</u>	<u>Page</u>
5. Inspection Procedures		5-13
A. Blade Damage		5-13
B. Grease or Oil Leakage.....		5-13
C. Vibration.....		5-15
D. Tachometer Inspection.....		5-16
E. Blade Track.....		5-19
F. Loose Blades		5-20
G. Corrosion		5-20
H. Spinner Damage.....		5-20
I. Electric De-ice System.....		5-20
J. Anti-ice System.....		5-21
6. Special Inspections		5-21
A. Overspeed/Overtorque		5-21
B. Propeller Ground Idle Operating Restrictions		5-24
C. Lightning Strike		5-30
D. Foreign Object Strike		5-31
E. Fire Damage or Heat Damage.....		5-33
7. Long Term Storage.....		5-34
MAINTENANCE PRACTICES.....		6-1
1. Cleaning		6-3
A. General Cleaning.....		6-3
B. Spinner Cleaning and Polishing.....		6-5
2. Lubrication.....		6-5
A. Lubrication Intervals.....		6-5
B. Lubrication Procedure.....		6-6
C. Approved Lubricants.....		6-8
3. Carbon Block Assemblies		6-9
A. Inspection		6-9
B. Replacement of A-3026 Carbon Block Unit in the A-3044 Carbon Block Assembly.....		6-9
C. Installation of the A-3044 Carbon Block Assembly		6-10

CONTENTS Page

4. Blade Repairs.....	6-11
A. Repair of Nicks and Gouges.....	6-13
B. Repair of Bent Blades.....	6-15
5. Painting After Repair.....	6-16
A. Painting of Aluminum Blades.....	6-18
6. Dynamic Balance.....	6-20
A. Overview.....	6-20
B. Inspection Procedures Before Balancing.....	6-21
C. Modifying Spinner Bulkhead to Accommodate Dynamic Balance Weights.....	6-21
D. Placement of Balance Weights for Dynamic Balance.....	6-22
7. Propeller Ice Protection Systems.....	6-23
A. Electric De-ice System.....	6-23
B. Anti-ice System.....	6-23

ANTI-ICE AND DE-ICE SYSTEMS 7-1

1. Introduction.....	7-3
A. Propeller De-Ice System.....	7-3
B. Propeller Anti-ice System.....	7-3
2. System Description.....	7-4
A. De-ice System.....	7-4
B. Anti-ice System.....	7-5
3. De-ice System Functional Tests.....	7-5
4. Anti-ice System Functional Tests.....	7-5
5. De-ice and Anti-ice System Inspections.....	7-6
A. De-ice System Inspections.....	7-6
B. Anti-ice System Inspections.....	7-6
6. De-ice and Anti-ice System Troubleshooting.....	7-7
A. De-ice System Troubleshooting.....	7-7
B. Anti-ice System Troubleshooting.....	7-7

RECORDS.....	8-1
1. Introduction	8-3
2. Record Keeping	8-3
A. Information to be Recorded	8-3

LIST OF ILLUSTRATIONS

Page

HC-B(3,5)()(-2() Propeller Assembly	Figure 2-1	2-4
Steel Hub Unit	Figure 2-2	2-5
HC-B(3,4,5)()(-3() Propeller Assembly	Figure 2-3	2-8
Start Lock Unit on HC-B(3,4,5)()(-3() Propeller Assembly	Figure 2-4	2-12
HC-B(3,4)()(-5() Propeller Assembly with One-piece Spinner Mounting Plate (Superseded Configuration).....	Figure 2-5	2-14
HC-B3()(-5() Propeller Assembly with Two-piece Spinner Mounting Plate (New Configuration)	Figure 2-6	2-15
HC-B(4,5)()(-5() Propeller Assembly with Two-piece Spinner Mounting Plate (New Configuration)	Figure 2-7	2-16
HC-A3VF-7() Propeller Assembly.....	Figure 2-8	2-22
HC-A3MVF-7() and HC-B3TF-7() Propeller Assembly	Figure 2-9	2-23
Governor in Onspeed Condition	Figure 2-10	2-32
Governor in Underspeed Condition	Figure 2-11	2-32
Governor in Overspeed Condition	Figure 2-12	2-32
Feathering Governor	Figure 2-13	2-34
Synchronizer/Synchrophaser Governor	Figure 2-14	2-34
Mounting Bolt and Washer	Figure 3-1	3-9

LIST OF ILLUSTRATIONS **Page**

Installing Propeller on Engine Flange.....	Figure 3-2	3-10
Diagram of Torquing Sequence for Propeller Mounting Bolts.....	Figure 3-3	3-11
Determining Torque Value When Using Torquing Adaptor.....	Figure 3-4	3-13
Beta System Puller for Decompressing -3 Series External Beta System	Figure 3-5	3-16
Carbon Block and Beta Ring Clearance.....	Figure 3-6	3-18
Carbon Block Assembly.....	Figure 3-7	3-18
Hub-to-Spacer O-ring Location in the Spacer.....	Figure 3-8	3-22
Installing the HC-B(3,4)()W-3() Propeller on the Engine Flange.....	Figure 3-9	3-24
Installing the Washer on the Mounting Stud..	Figure 3-10	3-26
One-piece Spinner Mounting Plate Installation.....	Figure 3-11	3-30
Beta Valve System	Figure 3-12	3-38
Cross Section View of the Beta Valve System	Figure 3-13	3-39
-7() Propeller Assembly	Figure 3-14	3-42
Spring Assembly to Cylinder Attachment Details.....	Figure 3-15	3-43
Piston to Link Arm Attachment Details.....	Figure 3-16	3-43
Filed Rod for Set Screw.....	Figure 3-17	3-48
Checking Blade Track.....	Figure 5-1	5-18
Blade Play	Figure 5-2	5-18
Turbine Engine Overspeed Limits	Figure 5-3	5-22
Turbine Engine Overtorque Limits.....	Figure 5-4	5-23

LIST OF ILLUSTRATIONSPage

Example of an Evaluation of Ground Idle RPM Check	Figure 5-5	5-25
Corrective Action Required	Figure 5-6	5-26
Grease Fitting	Figure 6-1	6-4
Lubrication Label	Figure 6-2	6-7
Repair Limitations	Figure 6-3	6-12

LIST OF TABLESPage

Propeller/Engine Flange O-rings	Table 3-1	3-8
Propeller Mounting Hardware	Table 3-2	3-8
Torque Table	Table 3-3	3-12
Approved Touch-up Paints	Table 6-1	6-17

(This page is intentionally blank.)

INTRODUCTION - CONTENTS

1. Purpose	1-3
2. Airworthiness Limitations	1-3
3. Airframe or Engine Modifications	1-4
4. Restrictions and Placards	1-4
5. General	1-5
A. Personnel Requirements	1-5
B. Maintenance Practices	1-5
C. Continued Airworthiness	1-8
D. Propeller Critical Parts	1-8
6. Reference Publications	1-9
7. Definitions	1-10
8. Abbreviations	1-14
9. Hartzell Propeller Inc. Product Support.....	1-15
10. Warranty Service.....	1-15
11. Hartzell Propeller Inc. Recommended Facilities	1-16

(This page is intentionally blank.)

1. Purpose

- A. This manual has been reviewed and accepted by the FAA. Additionally, the Airworthiness Limitations Section of this manual has been approved by the FAA.

CAUTION: KEEP THIS MANUAL WITH THE PROPELLER OR WITH THE AIRCRAFT ON WHICH IT IS INSTALLED, AT ALL TIMES. THE LOGBOOK RECORD WITHIN THIS MANUAL MUST BE MAINTAINED, RETAINED CONCURRENTLY, AND BECOME A PART OF THE AIRCRAFT AND ENGINE SERVICE RECORDS.

- B. This manual supports constant speed feathering and constant speed feathering and reversing steel hub turbine propellers with aluminum blades.

(1) The purpose of this manual is to enable qualified personnel to install, operate, and maintain a Hartzell Propeller Inc. Constant Speed Feathering or Constant Speed Feathering and Reversing Steel Hub Propeller. Separate manuals are available concerning overhaul procedures and specifications for the propeller.

(2) This manual includes several design types. Sample hub and blade model numbers within this design are included in the Description and Operation Chapter of this manual.

NOTE: All propeller models included in this manual use aluminum propeller blades. Propellers that use composite blades are supported by Hartzell Propeller Inc. Manual 146 (61-00-46).

2. Airworthiness Limitations

- A. Refer to the Airworthiness Limitations chapter of this manual for Airworthiness Limitations information.

3. Airframe or Engine Modifications

- A. Propellers are approved vibrationwise on airframe and engine combinations based on tests or analysis of similar installations. This data has demonstrated that propeller stress levels are affected by airframe configuration, airspeed, weight, power, engine configuration and flight maneuvers. Aircraft modifications which can effect propeller stress include, but are not limited to: aerodynamic changes ahead of or behind the propeller, realignment of the thrust axis, increasing or decreasing airspeed limits, increasing or decreasing weight limits (less significant on piston engines), and the addition of approved flight maneuvers (utility and aerobatic).
- B. Engine modifications can also affect the propeller. The two primary categories of engine modifications are those which affect structure and those which affect power. An example of a structural engine modification is the alteration of the crankshaft or damper of a piston engine. Any change to the weight, stiffness or tuning of rotating components could result in a potentially dangerous resonant condition which is not detectable by the pilot. Most common engine modifications affect the power during some phase of operation. Some increase the maximum power output, while others improve the power available during hot and high operation (flat rating) or at off-peak conditions. Examples of such engine modifications include, but are not limited to: changes to the compressor, power turbine or hot section of a turboprop engine; and on piston engines, the addition or alteration of a turbocharger or turbonormalizer, increased compression ratio, increased RPM, altered ignition timing, electronic ignition, full authority digital electronic controls (FADEC), or tuned induction or exhaust.
- C. All such modifications must be reviewed and approved by the propeller manufacturer prior to obtaining approval on the aircraft.

4. Restrictions and Placards

- A. The propellers covered by this manual may have a restricted operating range that requires a cockpit placard.
 - (1) The restrictions, if present, will vary depending on the propeller, blade, engine, and/or aircraft model.

- (2) Review the propeller and aircraft type certificate data sheet (TCDS), Pilot Operating Handbook (POH), and any applicable Airworthiness Directives for specific information.

5. General

A. Personnel Requirements

- (1) Inspection, Repair, and Overhaul
 - (a) Compliance to the applicable regulatory requirements established by the Federal Aviation Administration (FAA) or foreign equivalent is mandatory for anyone performing or accepting responsibility for any inspection and/or repair and/or overhaul of any Hartzell Propeller Inc. product.
 - (b) Personnel performing maintenance on steel hub propellers are expected to have sufficient training and certifications (when required by the applicable Aviation Authority) to accomplish the work required in a safe and airworthy manner.

B. Maintenance Practices

- (1) The propeller and its components are highly vulnerable to damage while they are removed from the engine. Properly protect all components until they are reinstalled on the engine.
- (2) Never attempt to move the aircraft by pulling on the propeller.
- (3) Avoid the use of blade paddles. Do not place the blade paddle in the area of the de-ice boot when applying torque to a blade assembly. Place the blade paddle in the thickest area of the blade, just outside of the de-ice boot. Use one blade paddle per blade.
- (4) Use only the approved consumables, e.g., cleaning agents, lubricants, etc.
- (5) Safe Handling of Paints and Chemicals
 - (a) Always use caution when handling or being exposed to paints and/or chemicals during propeller overhaul and maintenance procedures.
 - (b) Before using paint or chemicals, always read the manufacturer's label on the container and follow specified instructions and procedures.

- (c) Refer to the product's Material Safety Data Sheet (MSDS) for detailed information about physical properties, health, and physical hazards of any chemical.
- (6) Observe applicable torque values during maintenance.
- (7) Before installing the propeller on the engine, the propeller must be statically balanced. New propellers are statically balanced at Hartzell Propeller Inc. Overhauled propellers must be statically balanced by a certified propeller repair station with the appropriate rating before return to service.

NOTE: Dynamic balance is recommended, but may be accomplished at the discretion of the operator, unless specifically required by the airframe or engine manufacturer. Dynamic balancing is to be accomplished in accordance with the procedures and limitations in Maintenance Practices chapter of this manual. Additional procedures may be found in the aircraft maintenance manual.

- (8) As necessary, use a soft, non-graphite pencil or crayon to make identifying marks on components.
- (9) As applicable, follow military standard NASMS33540 for safety wire, safety cable, and cotter pin general practices. Use 0.032 inch (0.81 mm) diameter stainless steel safety wire unless otherwise indicated.

WARNING: DO NOT USE OBSOLETE OR OUTDATED INFORMATION. PERFORM ALL INSPECTIONS OR WORK IN ACCORDANCE WITH THE MOST RECENT REVISION OF THIS MANUAL. INFORMATION CONTAINED IN THIS MANUAL MAY BE SIGNIFICANTLY CHANGED FROM EARLIER REVISIONS. FAILURE TO COMPLY WITH THIS MANUAL OR THE USE OF OBSOLETE INFORMATION MAY CREATE AN UNSAFE CONDITION THAT MAY RESULT IN DEATH, SERIOUS BODILY INJURY, AND/OR SUBSTANTIAL PROPERTY DAMAGE. FOR THE MOST RECENT REVISION LEVEL OF THIS MANUAL, REFER TO THE HARTZELL PROPELLER INC. WEBSITE AT WWW.HARTZELLPROP.COM.

- (10)The information in this manual revision supersedes data in all previous published revisions of this manual.
- (11)The airframe manufacturer's manuals should be used in addition to the information in this manual due to possible special requirements for specific aircraft applications.
- (12)If the propeller is equipped with an ice protection system that uses components supplied by Hartzell Propeller Inc., applicable instructions and technical information for the components supplied by Hartzell Propeller Inc. can be found in the following publications available on the Hartzell Propeller Inc. website at www.hartzellprop.com:
 - (a) Manual 180 (30-61-80) - Propeller Ice Protection System Manual
 - (b) Manual 181 (30-60-81) - Propeller Ice Protection System Component Maintenance Manual
 - (c) Manual 182 (61-12-82) - Propeller Electrical De-ice Boot Removal and Installation Manual
 - (d) Manual 183 (61-12-83) - Propeller Anti-icing Boot Removal and Installation Manual

(13) Propeller ice protection system components not supplied by Hartzell Propeller Inc. are controlled by the applicable TC or STC holder's Instructions for Continued Airworthiness (ICA).

(14) Approved corrosion protection followed by approved paint must be applied to all aluminum blades. For information concerning the application of corrosion protection and paint, refer to the Maintenance Practices chapter of this manual. Operation of blades without the specified coatings and finishes, i.e., "polished blades", is not permitted.

C. Continued Airworthiness

(1) Operators are urged to stay informed of Airworthiness information using Hartzell Propeller Inc. Service Bulletins and Service Letters that are available from Hartzell Propeller Inc. distributors, or from the Hartzell Propeller Inc. factory by subscription. Selected information is also available on the Hartzell Propeller Inc. website at www.hartzellprop.com.

D. Propeller Critical Parts

(1) The following maintenance procedures may involve propeller critical parts. These procedures have been substantiated based on Engineering analysis that expects this product will be operated and maintained using the procedures and inspections provided in the Instructions for Continued Airworthiness (ICA) for this product. Refer to the Illustrated Parts List chapter of the applicable maintenance manual for the applicable propeller model for the identification of specific Critical Parts.

(2) Numerous propeller system parts can produce a propeller Major or Hazardous effect, even though those parts may not be considered as Critical Parts. The operating and maintenance procedures and inspections provided in the ICA for this product are, therefore, expected to be accomplished for all propeller system parts.

6. Reference Publications**A. Hartzell Propeller Inc. Publications**

NOTE: The following publications are referenced within this manual:

Active Hartzell Propeller Inc. Service Bulletins, Service Letters, Service Instructions, and Service Advisories.

Hartzell Propeller Inc. Manual No. 118F (61-10-18) - Three and Four-Blade Steel Hub Turbine Propeller Maintenance Manual

Hartzell Propeller Inc. Manual No. 127 (61-16-27) - Metal Spinner Assembly Maintenance Manual - Available on the Hartzell Propeller Inc. website at www.hartzellprop.com

Hartzell Propeller Inc. Manual No. 132A (61-10-32) - Five-Blade Steel Hub Turbine Propellers

Hartzell Propeller Inc. Manual No. 133C (61-13-33) - Aluminum Propeller Blade Maintenance Manual

Hartzell Propeller Inc. Manual No. 159 (61-02-59) - Application Guide - Available on the Hartzell Propeller Inc. website at www.hartzellprop.com

Hartzell Propeller Inc. Manual 165A (61-00-65) - Illustrated Tool and Equipment Manual - Available on the Hartzell Propeller Inc. website at www.hartzellprop.com

Hartzell Propeller Inc. Manual No. 180 (30-61-80) - Propeller Ice Protection System Manual - Available on the Hartzell Propeller Inc. website at www.hartzellprop.com

Hartzell Propeller Inc. Manual No. 181 (30-60-81) - Propeller Ice Protection System Component Maintenance Manual - Available on the Hartzell Propeller Inc. website at www.hartzellprop.com

Hartzell Propeller Inc. Manual No. 182 (61-12-82) - Propeller Electrical De-ice Boot Removal and Installation Manual - Available on the Hartzell Propeller Inc. website at www.hartzellprop.com

Hartzell Propeller Inc. Manual No. 183 (61-12-83) - Propeller Anti-icing Boot Removal and Installation Manual - Available on the Hartzell Propeller Inc. website at www.hartzellprop.com

Hartzell Propeller Inc. Manual No. 202A (61-01-02) - Standard Practices Manual, Volumes 1 through 11 (Volume 7, Consumable Materials is available on the Hartzell Propeller Inc. website at www.hartzellprop.com)

Hartzell Propeller Inc. Service Letter HC-SL-61-61Y - Overhaul Periods and Service Life Limits for Hartzell Propellers Inc. Aviation Components - Propellers, Governors, and Propeller Damper Assemblies - Available on the Hartzell Propeller Inc. website at www.hartzellprop.com

7. Definitions

A basic understanding of the following terms will assist in maintaining and operating Hartzell Propeller Inc. propeller systems.

<u>Term</u>	<u>Definition</u>
Annealed	Softening of material due to overexposure to heat
Blade Angle	Measurement of blade airfoil location described as the angle between the blade airfoil and the surface described by propeller rotation
Brinelling.	A depression caused by failure of the material in compression
Chord	A straight line distance between the leading and trailing edges of an airfoil
Cold Rolling	Compressive rolling process for the retention area of single shoulder blades that provides improved strength and resistance to fatigue
Constant Force	A force that is always present in some degree when the propeller is operating
Constant Speed	A propeller system that employs a governing device to maintain a selected engine RPM

<u>Term</u>	<u>Definition</u>
Corrosion	Gradual material removal or deterioration due to chemical action
Crack	Irregularly shaped separation within a material, sometimes visible as a narrow opening at the surface
Depression	Surface area where the material has been compressed but not removed
Distortion	Alteration of the original shape or size of a component
Erosion	Gradual wearing away or deterioration due to action of the elements
Exposure	Leaving material open to action of the elements
Feathering	The capability of blades to be rotated parallel to the relative wind, thus reducing aerodynamic drag
Gouge	Surface area where material has been removed
Hazardous Propeller Effect	The hazardous propeller effects are defined in Title 14 CFR section 35.15(g)(1)
Horizontal Balance	Balance between the blade tip and the center of the hub
Impact Damage	Damage that occurs when the propeller blade or hub assembly strikes, or is struck by, an object while in flight or on the ground
Major Propeller Effect	The major propeller effects are defined in Title 14 CFR section 35.15(g)(2)
Nick	Removal of paint and possibly a small amount of material



<u>Term</u>	<u>Definition</u>
Onspeed	Condition in which the RPM selected by the pilot through the propeller control lever and the actual engine (propeller) RPM are equal
Overhaul	The periodic disassembly, inspection, repair, refinish, and reassembly of a propeller assembly to maintain airworthiness
Overspeed	Condition in which the RPM of the propeller or engine exceeds predetermined maximum limits; the condition in which the engine (propeller) RPM is higher than the RPM selected by the pilot through the propeller control lever
Overspeed Damage . . .	Damage that occurs when the propeller hub assembly rotates at a speed greater than the maximum limit for which it is designed
Pitch	Same as "Blade Angle"
Pitting	Formation of a number of small, irregularly shaped cavities in surface material caused by corrosion or wear
Propeller Critical Parts .	A part on the propeller whose primary failure can result in a hazardous propeller effect, as determined by the safety analysis required by Title 14 CFR section 35.15
Reversing	The capability of rotating blades to a position to generate reverse thrust to slow the aircraft or back up
Scratch	Same as "Nick"



<u>Term</u>	<u>Definition</u>
Single Acting	Hydraulically actuated propeller that utilizes a single oil supply for pitch control
Superseded	Parts that are considered airworthy for continued flight but may no longer be available
Synchronizing	Adjusting the RPM of all the propellers of a multi-engine aircraft to the same RPM
Synchrophasing	A form of propeller sychronization in which not only the RPM of the engines (propellers) are held constant, but also the position of the propellers in relation to each other
Track.	In an assembled propeller, a measurement of the location of the blade tip with respect to the plane of rotation, used to verify face alignment and to compare blade tip location with respect to the locations of the other blades in the assembly
Underspeed	The condition in which the actual engine (propeller) RPM is lower than the RPM selected by the pilot through the propeller control lever
Variable Force	A force that may be applied or removed during propeller operation
Vertical Balance	Balance between the leading and trailing edges of a two-blade propeller with the blades positioned vertically
Windmilling	The rotation of an aircraft propeller caused by air flowing through it while the engine is not producing power



8. Abbreviations

<u>Abbreviation</u>	<u>Term</u>
AMM	Aircraft Maintenance Manual
AN	Air Force-Navy (or Army-Navy)
AOG	Aircraft on Ground
FAA	Federal Aviation Administration
FT-Lb	Foot-Pound
ICA	Instructions for Continued Airworthiness
ID	Inside Diameter
In-Lb	Inch-Pound
IPS	Inches Per Second
Lbs	Pounds
MIL-X-XXX	Military Specification
MPI	Major Periodic Inspection (Overhaul)
MS	Military Standard
MSDS	Material Safety Data Sheet
OD	Outside Diameter
NAS	National Aerospace Standards
NASM	National Aerospace Standards, Military
N•m	Newton-Meters
POH	Pilot's Operating Handbook
PSI	Pounds per Square Inch
RPM	Revolutions per Minute
TBO	Time Between Overhaul
TC	Type Certificate
TSN	Time Since New
TSO	Time Since Overhaul

NOTE: TSN/TSO is considered as the time accumulated between rotation and landing, i.e., flight time.

9. Hartzell Propeller Inc. Product Support

Hartzell Propeller Inc. is ready to assist you with questions concerning your propeller system. Hartzell Propeller Inc. Product Support may be reached during business hours (8:00 a.m. through 5:00 p.m., United States Eastern Time) at (937) 778-4379 or at (800) 942-7767, toll free from the United States and Canada. Hartzell Product Support can also be reached by fax at (937) 778-4391, and by email at techsupport@hartzellprop.com.

After business hours, you may leave a message on our 24 hour product support line at (937) 778-4376 or at (800) 942-7767, toll free from the United States and Canada. A technical representative will contact you during normal business hours. Urgent AOG support is also available 24 hours per day, seven days per week via this message service.

Additional information is available on our website at www.hartzellprop.com.

NOTE: When calling from outside the United States, dial (001) before dialing the above telephone numbers.

10. Warranty Service

If you believe you have a warranty claim, it is necessary to contact Hartzell Propeller's Warranty Administrator. Hartzell Propeller's Warranty Administrator will provide you with a *Warranty Application* form. It is necessary to complete this form and return it to the Warranty Administrator for evaluation **before proceeding with repair or inspection work**. Upon receipt of this form, the Warranty Administrator will provide instructions on how to proceed. Hartzell Propeller Inc. Warranty may be reached during business hours (8:00 a.m. through 5:00 p.m., United States Eastern Time) at 937-778-4380, or toll free at (800) 942-7767. Hartzell Propeller Inc. Warranty Administration can also be reached by fax, at (937) 778-4391, or by email at warranty@hartzellprop.com.

NOTE: When calling from outside the United States, dial (001) before dialing the above telephone numbers.

11. Hartzell Propeller Inc. Recommended Facilities

- A. Hartzell Propeller Inc. recommends using Hartzell Propeller Inc. approved distributors and repair facilities for the purchase, repair and overhaul of Hartzell Propeller Inc. propeller assemblies or components.
- B. Information about the Hartzell Propeller Inc. worldwide network of aftermarket distributors and approved repair facilities is available on the Hartzell Propeller Inc. website at www.hartzellprop.com.

DESCRIPTION AND OPERATION - CONTENTS

1. Functional Description of Constant Speed Propeller Types.....	2-5
A. Feathering Propellers HC-B(3,5)()(-2().....	2-5
B. Feathering and Reversing Propellers HC-B(3,4,5)()(-3() Series (External Beta System).....	2-9
C. Feathering and Reversing Propellers HC-B(3,4,5)()(-5() Series (Internal Beta System).....	2-17
D. Feathering and Reversing Propellers HC-()3()(-7() Series (Beta Valve System).....	2-24
2. Model Designation	2-28
A. Steel Hub Propeller Model Identification.....	2-28
B. Aluminum Blade Model Identification.....	2-31
3. Governors	2-33
A. Theory of Operation.....	2-33
4. Propeller Ice Protection Systems	2-36
A. Propeller Anti-ice System.....	2-36
B. Propeller De-ice System	2-37

LIST OF FIGURES

HC-B(3,5)() ()-2() Propeller Assembly	Figure 2-1	2-4
Steel Hub Unit	Figure 2-2	2-5
HC-B(3,4,5)() ()-3() Propeller Assembly	Figure 2-3	2-8
Start Lock Unit on HC-B(3,4,5)() ()-3() Propeller Assembly	Figure 2-4	2-12
HC-B(3,4)() ()-5() Propeller Assembly with One-piece Spinner Mounting Plate (Superseded Configuration).....	Figure 2-5	2-14
HC-B3() ()-5() Propeller Assembly with Two-piece Spinner Mounting Plate (New Configuration).....	Figure 2-6	2-15
HC-B(4,5)() ()-5() Propeller Assembly with Two-piece Spinner Mounting Plate (New Configuration).....	Figure 2-7	2-16
HC-A3VF-7() Propeller Assembly.....	Figure 2-8	2-22
■ HC-A3MVF-7() and HC-B3TF-7() Propeller Assembly	Figure 2-9	2-23
Governor in Onspeed Condition	Figure 2-10	2-32
Governor in Underspeed Condition	Figure 2-11	2-32
Governor in Overspeed Condition	Figure 2-12	2-32
Feathering Governor	Figure 2-13	2-34
Synchronizer/Synchrophaser Governor	Figure 2-14	2-34

(This page is intentionally blank.)

W10072

Note: This picture depicts two different spinner assemblies.

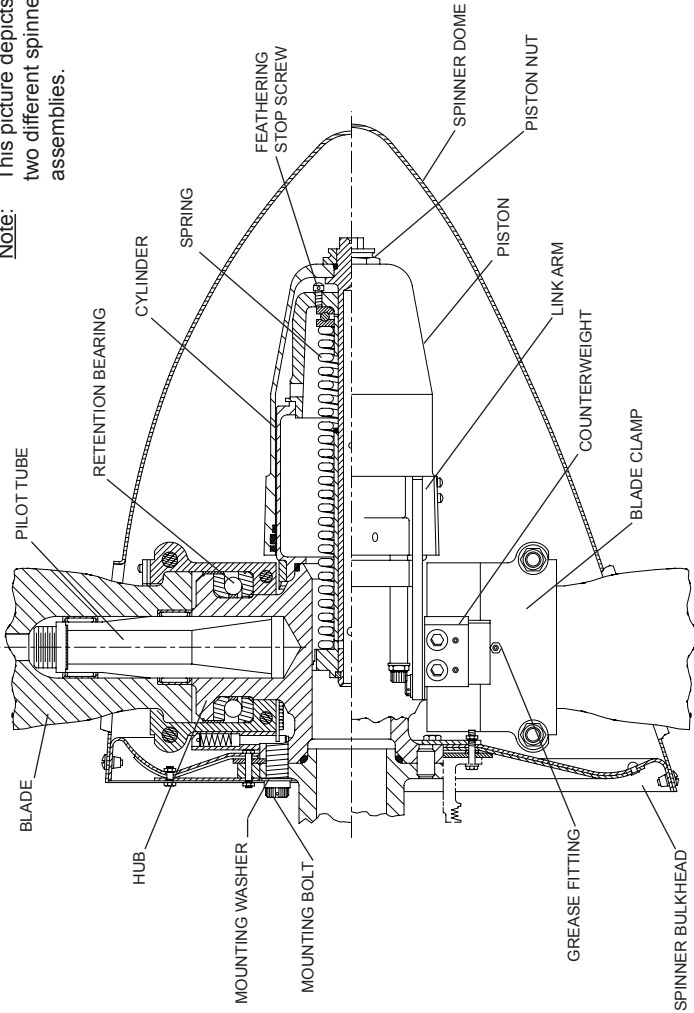

HC-B(3,5)()-2() Propeller Assembly
Figure 2-1

1. Functional Description of Constant Speed Propeller Types**A. Feathering Propellers HC-B(3,5)() ()-2()**

Refer to Figure 2-1. The propellers described in this section are constant speed, feathering, and non-reversing. They use a single oil supply from a governing device to hydraulically actuate a change in blade angle. The propellers can have three or five blades, and they are used primarily on Pratt and Whitney turbine engines.

Propeller blades and bearing assemblies are mounted on the arms of a steel hub unit (Figure 2-2) and are held in place by two-piece blade clamps. A cylinder is threaded onto the hub, and a feathering spring assembly is installed in the cylinder. A piston is placed over the cylinder and is connected by a link arm to each blade clamp. Propeller blade angle change is accomplished through the linear motion of the hydraulically actuated piston that is transmitted to each blade through the link arms and blade clamps.

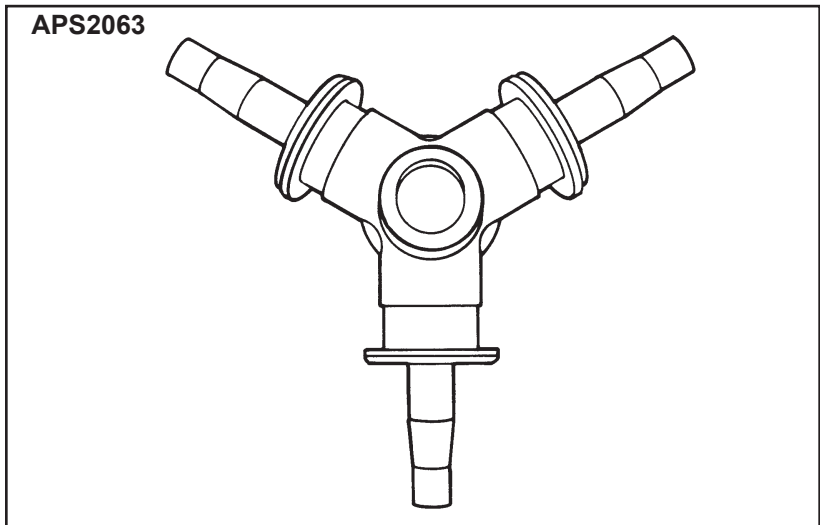

**Steel Hub Unit
Figure 2-2**

While the propeller is operating, the following forces are constantly present: 1) spring force, 2) counterweight force, 3) centrifugal twisting moment of each blade, and 4) blade aerodynamic twisting forces. The spring and counterweight forces attempt to rotate the blades to higher blade angle, while the centrifugal twisting moment of each blade is generally toward lower blade angle. Blade aerodynamic twisting force is usually very small in relation to the other forces and can attempt to increase or decrease blade angle.

The summation of the propeller forces is toward higher pitch (low RPM) and is opposed by a variable force toward lower pitch (high RPM). The variable force is oil under pressure from a governor with an internal pump, which is mounted on and driven by the engine. The oil from the governor is supplied to the propeller and hydraulic piston through a hollow engine shaft. Increasing the volume of oil within the piston and cylinder will decrease the blade angle and increase propeller RPM. Decreasing the volume of oil will increase blade angle and decrease propeller RPM. By changing the blade angle, the governor can vary the load on the engine and maintain constant engine RPM (within limits), independent of where the power lever is set. The governor uses engine speed sensing mechanisms that allow it to supply or drain oil as necessary to maintain constant engine speed (RPM).

If governor supplied oil is lost during operation, the propeller will increase pitch and feather. Feathering occurs because the summation of internal propeller forces causes the oil to drain out of the propeller until the feather stop position is reached.

Normal in-flight unfeathering is accomplished when the pilot positions the propeller condition lever into the normal flight (governing) range and restarts the engine. As engine speed increases, the governor supplies oil to the propeller, and the blade angle decreases.

(This page is intentionally blank.)

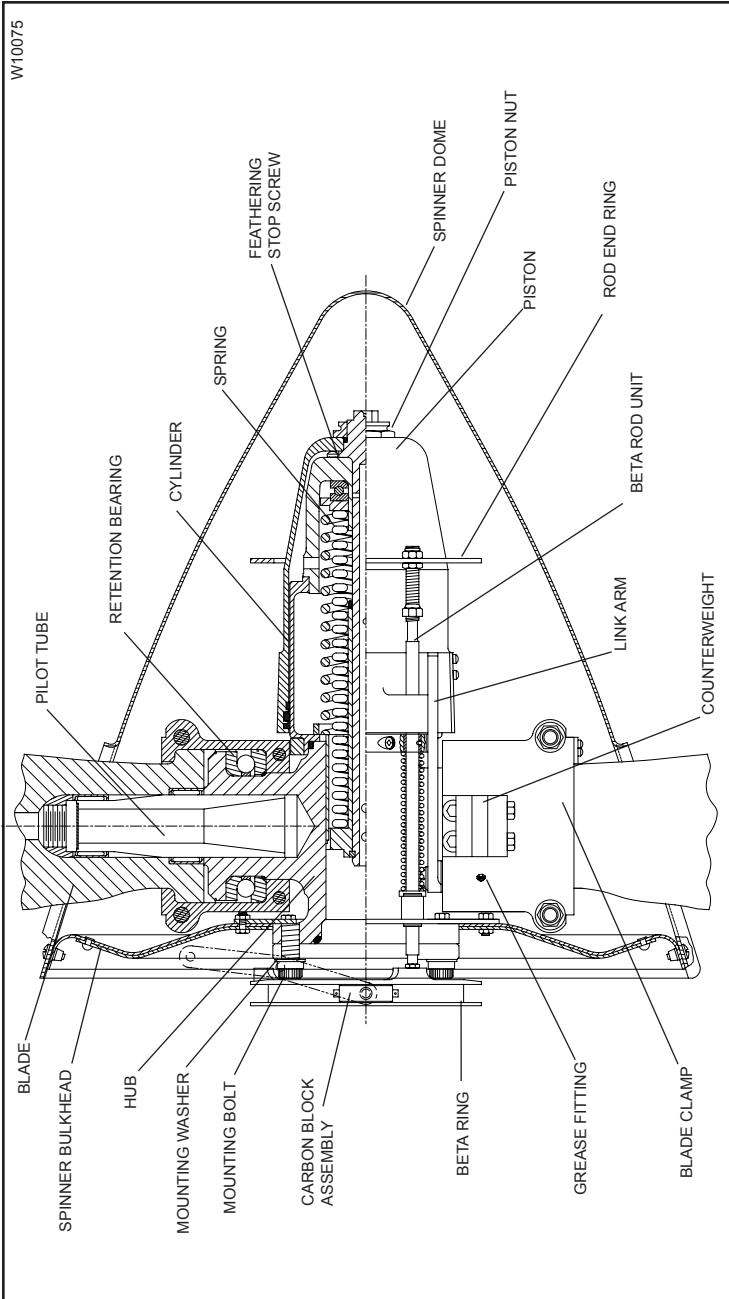

**HC-B(3,4,5)()-3() Propeller Assembly
Figure 2-3**

B. Feathering and Reversing Propellers
HC-B(3,4,5)()(-3() Series (External Beta System)

Refer to Figure 2-3. The propellers described in this section are constant speed, feathering and reversing. They use a single oil supply from a governing device to hydraulically actuate a change in blade angle. The propellers can have three, four, or five blades, and they are used primarily on Pratt and Whitney and Walter turbine engines.

Propeller blades and bearing assemblies are mounted on the arms of a steel hub unit (Figure 2-2) and are held in place by two-piece blade clamps. A cylinder is threaded onto the hub, and a feathering spring assembly is installed in the cylinder. A piston is placed over the cylinder and is connected by a link arm to each blade clamp. Propeller blade angle change is accomplished through the linear motion of the hydraulically actuated piston that is transmitted to each blade through the link arms and blade clamps.

While the propeller is operating, the following forces are constantly present: 1) spring force, 2) counterweight force, 3) centrifugal twisting moment of each blade, and 4) blade aerodynamic twisting forces. The spring and counterweight forces attempt to rotate the blades to higher blade angle, while the centrifugal twisting moment of each blade is generally acting toward lower blade angle. Blade aerodynamic twisting force is usually very small in relation to the other forces and can attempt to increase or decrease blade angle.

The summation of the propeller forces is toward higher pitch (low RPM) and is opposed by a variable force toward lower pitch (high RPM). The variable force is oil under pressure from a governor with an internal pump, which is mounted on and driven by the engine. The oil from the governor is supplied to the propeller and hydraulic piston through a hollow engine shaft. Increasing the volume of oil within the piston and cylinder will decrease the blade angle and increase propeller RPM. Decreasing the volume of oil will increase blade angle and decrease propeller RPM. By changing the blade angle, the governor can vary the load on the engine and maintain constant engine RPM (within limits), independent of where the power lever is set. The governor uses engine speed sensing mechanisms that allow it to supply or drain oil as necessary to maintain constant engine speed (RPM).

If governor supplied oil is lost during operation, the propeller will increase pitch and feather. Feathering occurs because the summation of internal propeller forces causes the oil to drain out of the propeller until the feather stop position is reached.

Normal in-flight feathering is accomplished when the pilot retards the propeller condition lever past the feather detent. This allows control oil to drain from the propeller and return to the engine sump. Engine shutdown is normally accomplished during the feathering process.

Normal in-flight unfeathering is accomplished when the pilot positions the propeller condition lever into the normal flight (governing) range and restarts the engine. As engine speed increases, the governor supplies oil to the propeller, and the blade angle decreases.

In reverse mode of operation, the governor operates in an underspeed condition to act strictly as a source of pressurized oil, without attempting to control RPM. Control of the propeller blade angle in reverse is accomplished through the beta valve.

NOTE: The beta valve is normally built into the base of the governor.

The propeller is reversed by manually repositioning the cockpit-control to cause the beta valve to supply oil from the governor pump to the propeller. An external propeller feedback mechanism, which include a beta ring and carbon block assembly, communicate propeller blade angle position to the beta valve.

When the propeller reaches the desired reverse position, movement of the beta ring and carbon block assembly, initiated by the propeller piston, causes the beta valve to shut off the flow of oil to the propeller. Any additional unwanted movement of the propeller toward reverse, or any movement of the manually positioned beta valve control toward high pitch position will cause the beta valve to drain oil from the propeller to increase pitch.

With some applications, it is undesirable to feather the propeller when the engine is stopped after landing the aircraft.

To prevent feathering during normal engine shutdown, the propeller incorporates spring-energized latch pins called start lock units (Figure 2-4). These units are installed either on a two-piece spinner mounting plate or on the spinner bulkhead, which is bolted to the propeller hub flange. If propeller rotation is approximately 800 RPM or above, the start lock units are disengaged from the blade clamp mounted plates by centrifugal force acting on the latch pins to compress the springs (within the units). When the RPM drops below 800, the springs overcome the centrifugal force and move the latch pins to engage the clamp-mounted plate, preventing blade angle movement to feather.

Shortly after engine start-up, with the propeller RPM above 800, the latch pins in the start lock units will still retain the blade angle. To release the latch pins, it is necessary to manually actuate the propeller slightly toward reverse. This will move the clamp-mounted plate, allowing the latch pins to slide freely. Centrifugal force will compress the springs and disengage the pins from the plate.

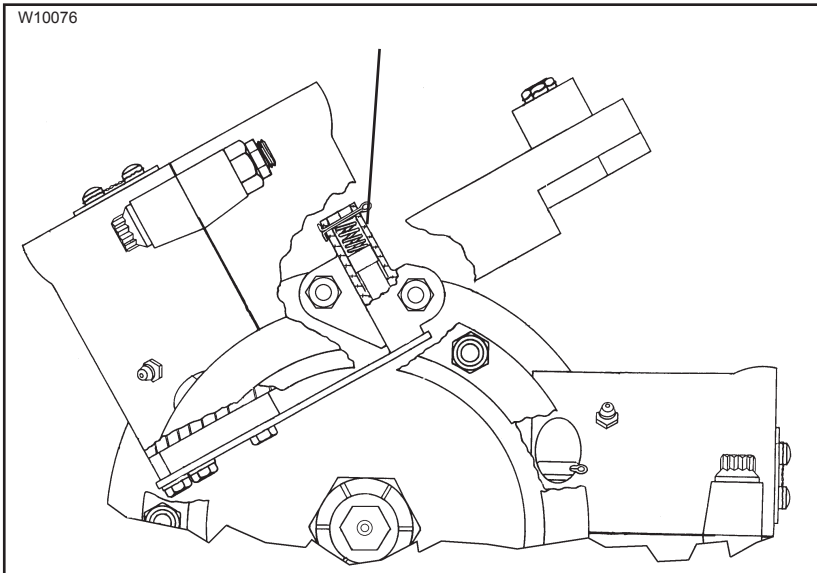

Start Lock Unit on HC-B(3,4,5) () (-3) ()
Propeller Assembly
Figure 2-4

(This page is intentionally blank.)



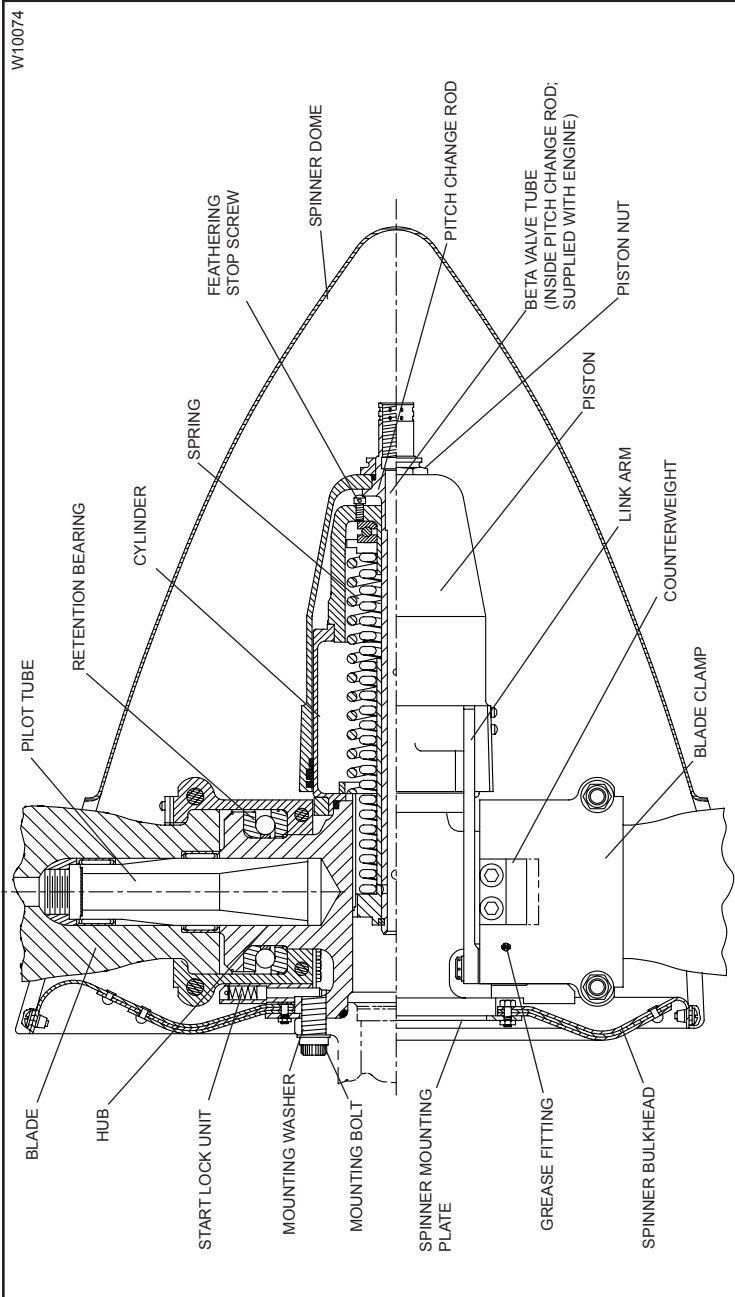

**HC-B(3,4)()(-5) Propeller Assembly with One-piece Spinner Mounting Plate
(Superseded Configuration)
Figure 2-5**

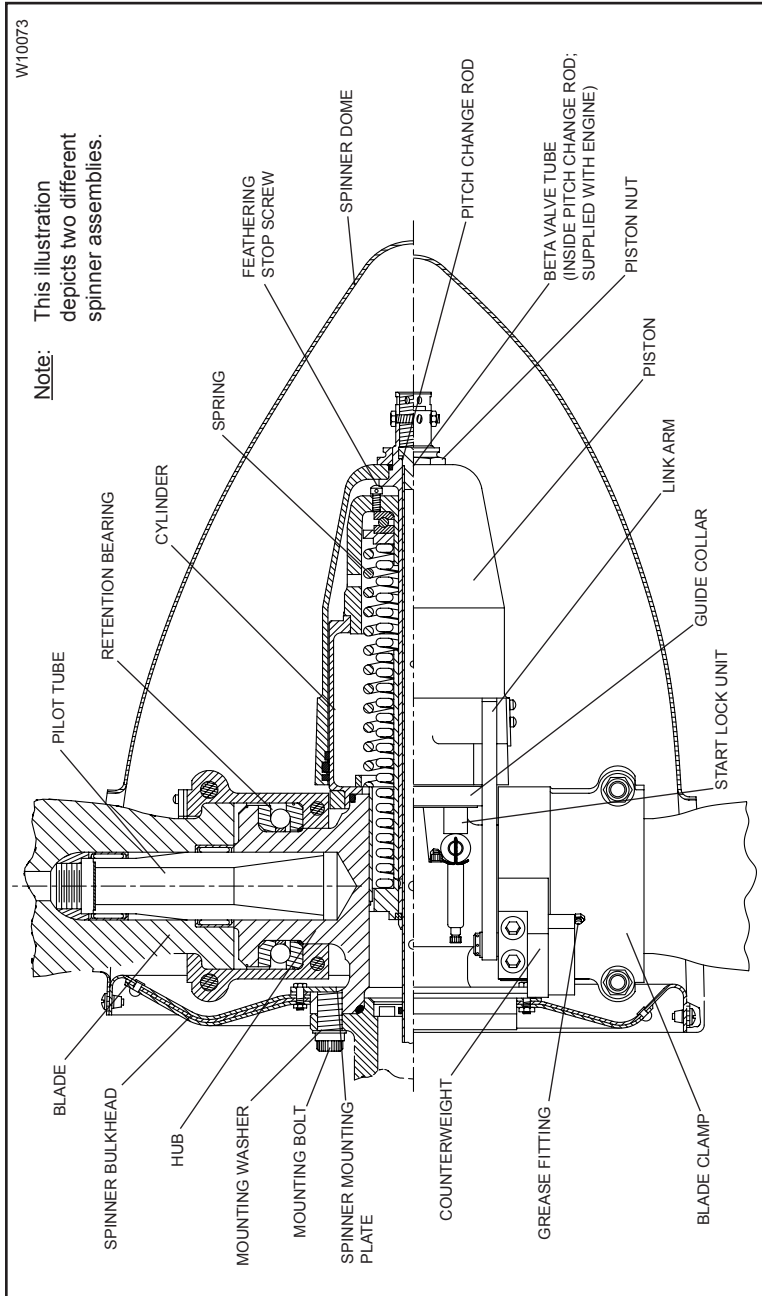

HC-B3()(-5) Propeller Assembly with Two-piece Spinner Mounting Plate (New Configuration) Figure 2-6

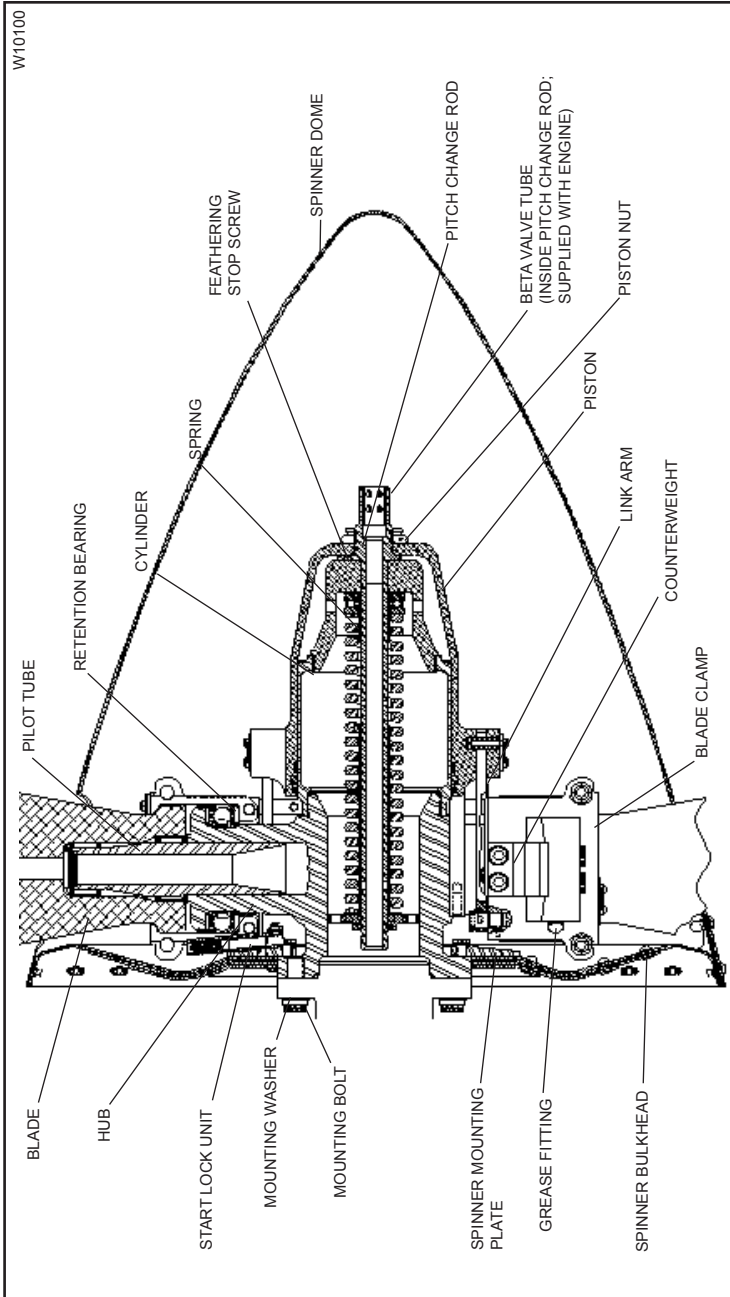

HC-B(4,5)(X)-5() Propeller Assembly with Two-piece Spinner Mounting Plate (New Configuration)
Figure 2-7

C. Feathering and Reversing Propellers
HC-B(3,4,5)() ()-5() Series (Internal Beta System)

Refer to Figures 2-5 through 2-7. The propellers described in this section are constant speed, feathering and reversing. They use a single oil supply from a governing device to hydraulically actuate a change in blade angle. The propellers can have three, four, or five blades, and are used primarily on Garrett (Allied Signal) turbine engines.

Propeller blades and bearing assemblies are mounted on the arms of a steel hub unit (Figure 2-2) and are held in place by two-piece blade clamps. A cylinder is threaded onto the hub, and a feathering spring assembly is installed in the cylinder. A piston is placed over the cylinder and is connected by a link arm to each blade clamp. Propeller blade angle change is accomplished through the linear motion of the hydraulically actuated piston that is transmitted to each blade through the link arms and blade clamps.

While the propeller is operating, the following forces are constantly present: 1) spring force, 2) counterweight force, 3) centrifugal twisting moment of each blade, and 4) blade aerodynamic twisting forces. The spring and counterweight forces attempt to rotate the blades to higher blade angle, while the centrifugal twisting moment of each blade is generally toward lower blade angle. Blade aerodynamic twisting force is usually very small in relation to the other forces and can attempt to increase or decrease blade angle.

The summation of the propeller forces is toward higher pitch (low RPM) and is opposed by a variable force toward lower pitch (high RPM). The variable force is oil under pressure from a governor with an internal pump, which is mounted on and driven by the engine. The oil from the governor is supplied to the propeller and hydraulic piston through a hollow engine shaft. Increasing the volume of oil within the piston and cylinder will decrease the blade angle and increase propeller RPM. Decreasing the volume of oil will increase blade angle and decrease propeller RPM. By changing the blade angle, the governor can vary the load on the engine and maintain constant engine RPM (within limits), independent of where the power lever is set. The governor uses engine speed sensing mechanisms that allow it to supply or drain oil as necessary to maintain constant engine speed (RPM).

If governor supplied oil is lost during operation, the propeller will increase pitch and feather. Feathering occurs because the summation of internal propeller forces causes the oil to drain out of the propeller until the feather stop position is reached.

Normal in-flight feathering is accomplished when the pilot places the propeller condition lever into feather position. This allows control oil to drain from the propeller and return to the engine sump. Engine shutdown is normally accomplished during the feathering process.

Normal in-flight unfeathering is accomplished when the pilot positions the propeller condition lever into the normal flight (governing) range, activates the auxiliary pump to decrease blade pitch, and restarts the engine. As engine speed increases, the governor supplies oil to the propeller, and the blade angle decreases until it reaches an onspeed condition.

In reverse mode of operation, the governor operates in an underspeed condition to act strictly as a source of pressurized oil, without attempting to control RPM. Control of the propeller blade angle in reverse is accomplished through the beta valve.

NOTE: The beta valve is normally located on the side of the gearbox opposite the propeller.

The propeller is reversed by manually repositioning the power lever within the beta range to cause the beta valve to supply oil from the governor pump to the propeller. A beta rod inserted into the front of the propeller communicates propeller blade angle position to the beta valve. When the propeller reaches the desired reverse position, movement of the beta rod causes the beta valve to shut off the flow of oil to the propeller. Any additional unwanted movement of the propeller toward reverse, or any movement of the manually positioned beta valve control toward high pitch position will cause the beta valve to drain oil from the propeller to increase pitch.

It is undesirable to feather the propeller when the engine is stopped after landing the aircraft. This propeller type is normally installed on a fixed shaft engine that causes the propeller to rotate during an engine start process. If the propeller is in feather position, an overload on the electric engine starter will occur.

To prevent feathering during normal engine shutdown, the propeller incorporates spring-energized latch pins called start lock units. These units are installed either on a two-piece spinner mounting plate or on the spinner bulkhead, which is bolted to the propeller hub flange. If propeller rotation is approximately 800 RPM or above, the start lock units are disengaged from the blade clamp mounted plates by centrifugal force acting on the latch pins to compress the springs (within the units). When the RPM drops below 800, the springs overcome the centrifugal force and move the latch pins to engage the clamp-mounted plate, preventing blade angle movement to feather.

CAUTION: RELEASING THE START LOCKS AT SIGNIFICANTLY HIGHER THAN 800 RPM OR AT HIGH RPM CAN CAUSE DAMAGE TO THE START LOCKS.

Shortly after engine start-up, with the propeller RPM above 800, the latch pins in the start lock units will still retain the blade angle. To release the latch pins, it is necessary to manually actuate the propeller slightly toward reverse. This will move the clamp-mounted plate, allowing the latch pins to slide freely. Centrifugal force will compress the springs and disengage the pins from the plate.

Hartzell Propeller Inc. -5 series propellers incorporated various start lock unit configurations.

- (1) Certain three-bladed and four-bladed propellers incorporate a one-piece spinner mounting plate that is pinched between the hub and engine flanges. The start lock units are installed on the spinner bulkhead.

NOTE: The one-piece spinner mounting plate was superseded by a two-piece spinner mounting plate on current production propellers.

- (2) Current production of four-bladed and five-bladed propellers incorporate a two-piece spinner mounting plate that bolts onto the propeller hub flange. The start lock units are installed onto the spinner mounting plate.
- (3) Current production of three-bladed propellers incorporate a two-piece spinner mounting plate that bolts onto the propeller hub flange. The start lock units are mounted on the guide collar.

(This page is intentionally blank.)



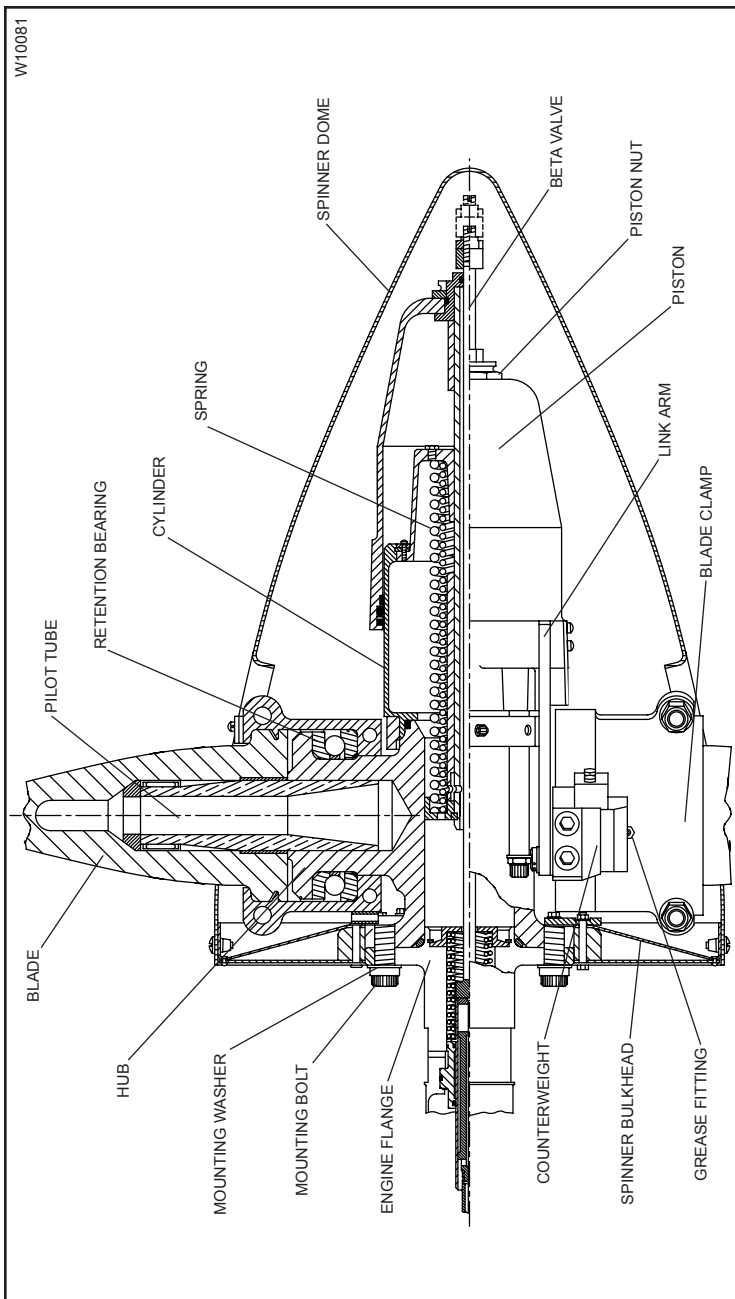

HC-A3VF-7() Propeller Assembly
Figure 2-8

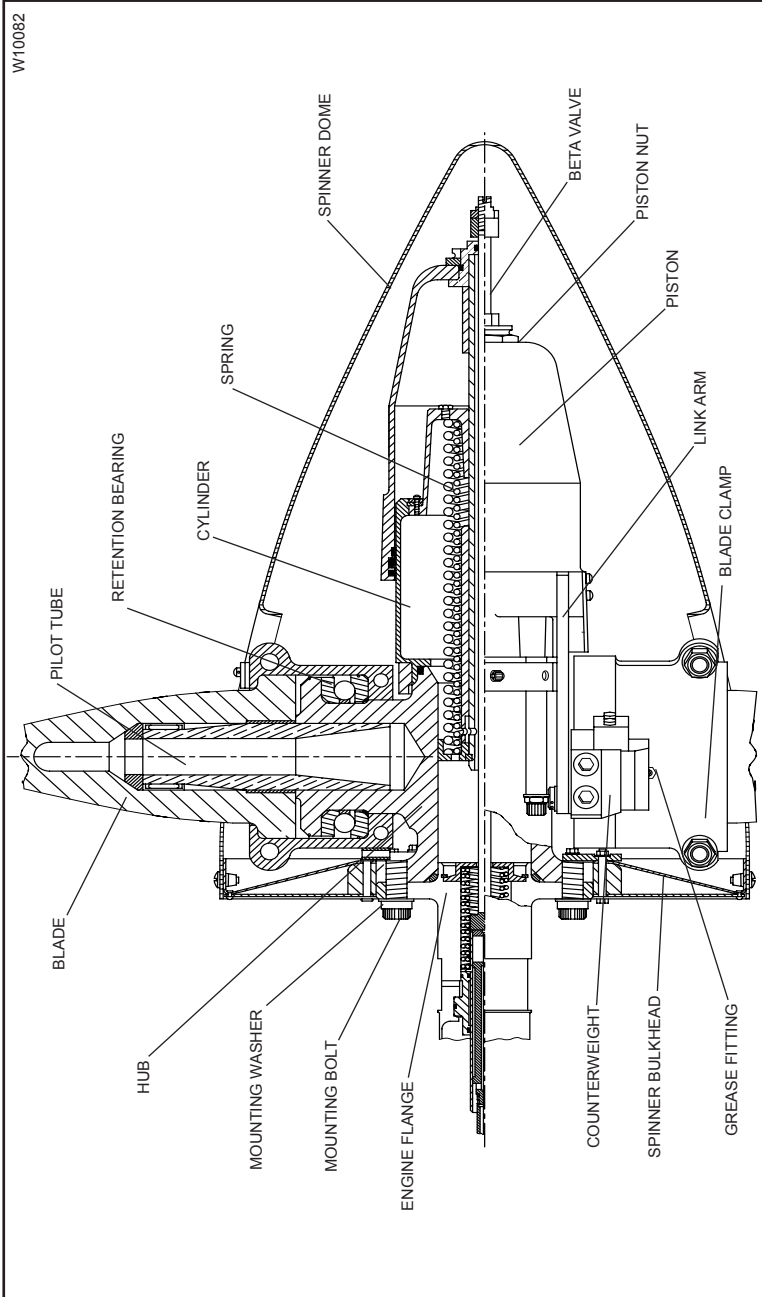

HC-A3MVF-7() and HC-B3TF-7() Propeller Assembly
Figure 2-9

D. Feathering and Reversing Propellers
HC-()3()(-)7() Series (Beta Valve System)

Refer to Figures 2-8 and 2-9. The propellers described in this section are constant speed, feathering and reversing. They use a single oil supply from a governing device to hydraulically actuate a change in blade angle. The propellers have three blades, and are used primarily on Allison 250B17() series turbine engines.

Propeller blades and bearing assemblies are mounted on the arms of a steel hub unit (Figure 2-2) and are held in place by two-piece blade clamps. A cylinder is threaded onto the hub, and a feathering spring assembly is installed in the cylinder. A piston is placed over the cylinder and is connected by a link arm to each blade clamp. Propeller blade angle change is accomplished through the linear motion of the hydraulically actuated piston that is transmitted to each blade through the link arms and blade clamps.

While the propeller is operating, the following forces are constantly present: 1) spring force, 2) counterweight force, 3) centrifugal twisting moment of each blade, and 4) blade aerodynamic twisting forces. The spring and counterweight forces attempt to rotate the blades to higher blade angle, while the centrifugal twisting moment of each blade is generally toward lower blade angle. Blade aerodynamic twisting force is usually very small in relation to the other forces and can attempt to increase or decrease blade angle.

The summation of the propeller forces is toward higher pitch (low RPM) and is opposed by a variable force toward lower pitch (high RPM). The variable force is oil under pressure from a governor with an internal pump, which is mounted on and driven by the engine. The oil from the governor is supplied to the propeller and hydraulic piston through a hollow engine shaft. Increasing the volume of oil within the piston and cylinder will decrease the blade angle and increase propeller RPM. Decreasing the volume of oil will increase blade angle and decrease propeller RPM. By changing the blade angle, the governor can vary the load on the engine and maintain constant engine RPM (within limits), independent of where the power lever is set. The governor uses engine speed sensing mechanisms that allow it to supply or drain oil as necessary to maintain constant engine speed (RPM).

If governor supplied oil is lost during operation, the propeller will increase pitch and feather. Feathering occurs because the summation of internal propeller forces causes the oil to drain out of the propeller until the feather stop position is reached.

Normal in-flight feathering is accomplished when the pilot retards the propeller condition lever past the feather detent. This allows control oil to drain from the propeller and return to the engine sump. Engine shutdown is normally accomplished during the feathering process.

Normal in-flight unfeathering is accomplished when the pilot positions the propeller condition lever into the normal flight (governing) range, activates the auxiliary pump to decrease blade pitch, and restarts the engine. As engine speed increases, the governor supplies oil to the propeller, and the blade angle decreases.

In reverse mode of operation, the governor is reset to act as a source of pressurized oil. Control of the propeller then is transferred to the beta valve.

The propeller is reversed by manually repositioning the cockpit-controlled cable to cause the beta valve to port oil from the governor pump to the propeller.

When the propeller reaches desired reverse position, movement of the beta feedback system will cause the beta valve to shut off flow of oil to the propeller. Any further unwanted movement of the propeller toward reverse or any movement of the manually positioned cable toward high pitch position will cause the beta valve to drain oil from the propeller to increase pitch.

(This page is intentionally blank.)



2. Model Designation

The following pages illustrate sample model designations for Hartzell Propeller Inc. steel hub turbine propeller hub assemblies and blades. Hartzell Propeller Inc. uses a model designation to identify specific propeller and blade assemblies.

Example: HC-B5MA-5A/M11276NK-3. A slash mark separates the propeller and blade designations.

A. Steel Hub Propeller Model Identification

The propeller model designation is impression stamped on the propeller hub.

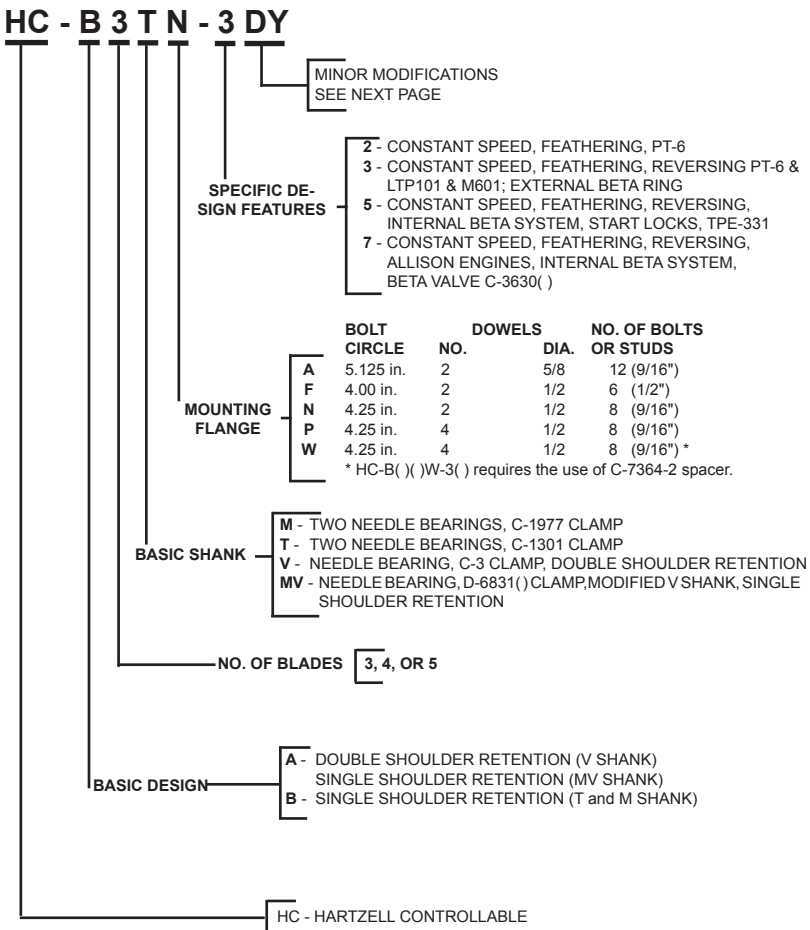

HC - B 3 T N - 3 D Y

MINOR MODIFICATIONS

HC-A3VF-7

- A** - ADDITION OF A-1869 SPACER - NONFEATHERING
- B** - 838-113 CLAMP ASSEMBLY, B-3663-3 SLUGS (SI 151)

HC-B3TF-7

- A** - 838-93 CLAMP ASSEMBLY 1835-39 SPINNER, A3491 SPINNER MOUNTING KIT
- B** - ADDITION OF A-1869 SPACER - NONFEATHERING
- C** - A-719 WASHERS
- L** - LEFT HAND ROTATION

HC-B3(T,W)N-2

- B** - NONPOLISHED SPINNER, SWEARINGEN
- L** - LEFT HAND ROTATION

HC-B3TN-3

- A** - 831-23A, -47, -46 SPRING ASSEMBLY 3 SPRINGS, OLD RODS
- B** - B-3475A-2 LOW STOP ROD UNIT ALTERNATE B-3475-2, B-3002-2
- C** - SAME AS -3B EXCEPT 831-23A, -47, -46 SPRING ASSEMBLY 3 SPRINGS NEW RODS
- D** - SAME AS -3C EXCEPT 831-33 SPRING ASSEMBLY
- E** - SAME AS -3A EXCEPT B-3475A-10 LOW STOP ROD UNIT ALTERNATE B-3475-10, B-3002-10
- F** - SAME AS -3E EXCEPT 838-88 CLAMP ASSEMBLY (SAME AS -3E EXCEPT COUNTERWEIGHTS)
- G** - SAME AS -3C EXCEPT 838-88 CLAMP ASSEMBLY (SAME AS -3C EXCEPT COUNTERWEIGHTS)
- H** - SAME AS -3B EXCEPT COUNTERWEIGHT SLUGS AND COUNTERWEIGHT ANGLE
- K** - SAME AS -3C EXCEPT EXT. FEATHER STOP (B-1368-14 PISTON)
- L** - LEFT HAND ROTATION
- M** - SAME AS -3B EXCEPT EXT. FEATHER STOP (B-1368-14 PISTON)
- N** - SAME AS -3G EXCEPT EXT. FEATHER STOP (B-1368-14 PISTON)
- P** - SAME AS -2H EXCEPT EXT. FEATHER STOP (B-1368-14 PISTON)
- S** - STOP MOUNTING KIT A-3432-3
- Y** - STOP MOUNTING KIT

HC-B5MA-3

- A** - SAME AS -3 EXCEPT BLADE ANGLE SETUP
- B** - SAME AS -3 EXCEPT D-5574P SPINNER ASSEMBLY AND BLADE ANGLE SETUP
- C** - SAME AS -3 EXCEPT D-5497-1 SPINNER ASSEMBLY AND BLADE ANGLE SETUP
- D** - SAME AS -3 EXCEPT BLADE ANGLE SETUP
- J** - SAME AS -3B EXCEPT 838-107 CLAMP ASSEMBLY AND BLADE ANGLE SETUP

HC-B3TN-5

- C** - PRP-914-21 PILOT TUBE 'O' RING, 831-30, -48, -45 SPRING ASSEMBLY
- D** - SAME AS -5C EXCEPT 838-71 CLAMP ASSEMBLY
- E** - SAME AS -5C EXCEPT 1368-12 PISTON ASSEMBLY
- F** - SAME AS -5D EXCEPT 1368-12 PISTON ASSEMBLY
- G** - SAME AS -5E EXCEPT A-3757 STOP PLATES AND 831-38, 48, -45 SPRING ASSEMBLY
- K** - SAME AS -5F EXCEPT 838-95 CLAMP ASSEMBLY AND NO. 831-30 SPRING ASSEMBLY
- L** - LEFT HAND ROTATION
- M** - 830-36 OR -37 STOP UNIT FOR -5C, -5E, -5G
- N** - 830-36 OR -37 STOP UNIT FOR -5D, -5F
- P** - 830-36, OR -37 STOP UNIT FOR -5K

HC-B3MN-5

- L** - LEFT HAND ROTATION

HC-B4MN-3

- A** - 838-103 CLAMP ASSEMBLY
- L** - LEFT HAND ROTATION

HC-B4MN-5

- A** - 834-13 STOP COLLAR, A-3495 STOP PLATE, 838-97L CLAMP ASSEMBLY, 832-44L PISTON ASSEMBLY
- L** - LEFT HAND ROTATION

HC - B 3 T N - 3 D Y

MINOR MODIFICATIONS, CONTINUED

HC-B4MP-3

- A - D-4846P SPINNER ASSEMBLY, 838-109 CLAMP ASSEMBLY
- B - B-3334 LOW STOP COLLAR
- C - D-5519P SPINNER ASSEMBLY
- L - LEFT HAND ROTATION

HC-B4TN-3

- A - B-3475-3 LOW STOP ROD UNIT ALTERNATE B-3475-3, B-3002-3, B-3001-3 COLLAR, OPTIONAL 838-89 CLAMP ASSEMBLY
- B - SAME AS -3A EXCEPT B-3334 COLLAR
- C - SAME AS -3A EXCEPT 838-105 CLAMP ASSEMBLY
- L - LEFT HAND ROTATION

HC-B4TW-3

(NO MINOR MODIFICATIONS APPLY)

HC-B4TN-5

- A - MINOR MODIFICATION
- C - PRP-914-21 PILOT TUBE 'O' RING (C & subsequent)
- D - SAME AS -5CL EXCEPT 838-92 CLAMP
- E - SAME AS -5D EXCEPT 838-98 CLAMP & SPINNER
- F - SAME AS -5C EXCEPT 830-34 STOP UNIT
- G - SAME AS -5D EXCEPT A-3495 STOP PLATE, 830-34 STOP UNIT
- H - SAME AS -5EL EXCEPT A-3495 STOP PLATE
- J - SAME AS -5G EXCEPT 832-44 PISTON ASSEMBLY
- K - SAME AS -5H EXCEPT 832-44 PISTON ASSEMBLY
- L - LEFT HAND ROTATION
- M - SAME AS -5J EXCEPT D-3434-7P SPINNER ASSEMBLY
- N - SAME AS -5K EXCEPT BLADES AND COUNTERWEIGHT

HC-B5MP-3

- A - C-3317-121 PILOT TUBE O-RING, A880-2A PISTON NUT, 831-50 SPRING ASSEMBLY, 832-39 PISTON ASSEMBLY, 834-19 GUIDE COLLAR, C-4019-1 LOW STOP COLLAR
- B - SAME AS -3A EXCEPT 831-51 SPRING ASSEMBLY
- C - SAME AS -3A EXCEPT 838-107 CLAMP ASSEMBLY
- L - LEFT HAND ROTATION

HC-B5MA-5

- A - SAME AS -5 EXCEPT BLADE ANGLE SETUP

B. Aluminum Blade Model Identification

The blade designation is impression stamped on the blade butt end (internal) and is either on a decal or ink stamped on the blade camber side (external).

prop model/M11276NK-3

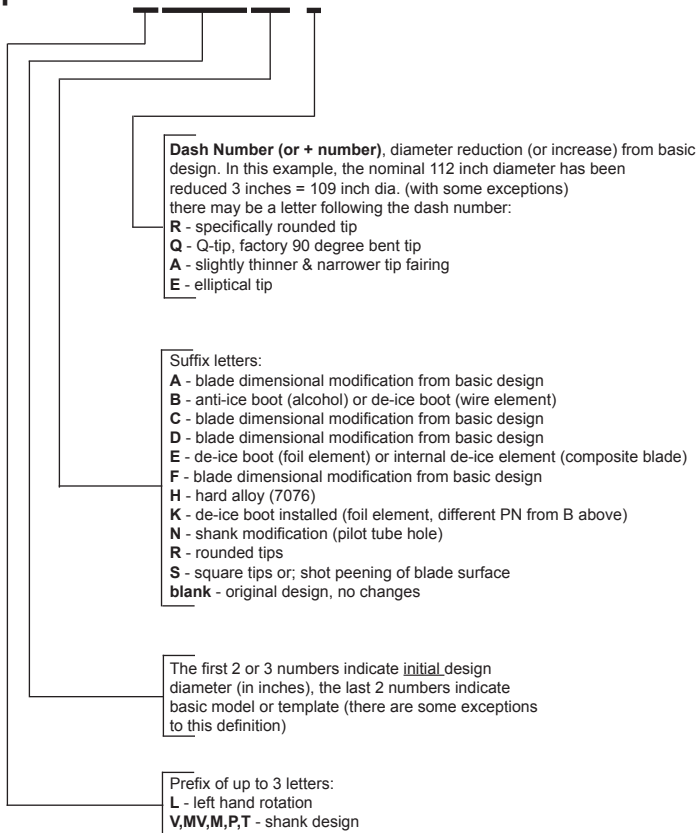

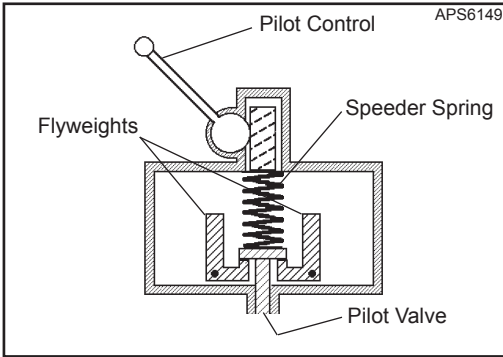

Governor in Onspeed Condition
Figure 2-10

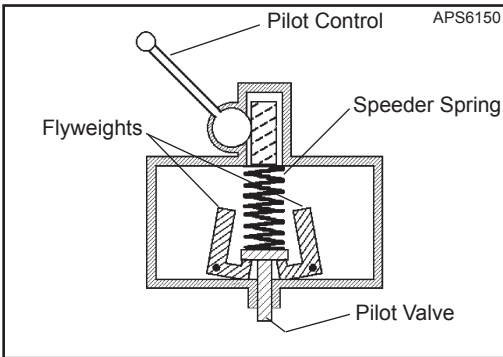

Governor in Underspeed Condition
Figure 2-11

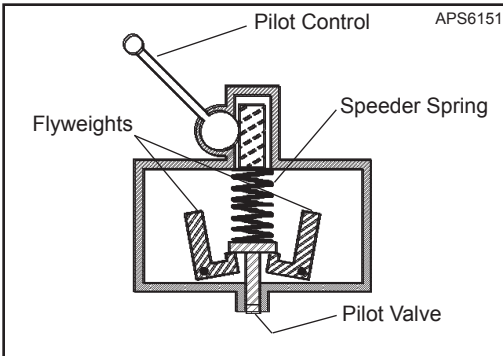

Governor in Overspeed Condition
Figure 2-12

3. Governors

A. Theory of Operation

- (1) A governor is an engine RPM sensing device and high pressure oil pump. In a constant speed propeller system, the governor responds to a change in engine RPM by directing oil under pressure to the propeller hydraulic cylinder or by releasing oil from the hydraulic cylinder. The change in oil volume in the hydraulic cylinder changes the blade angle and maintains the propeller system RPM to the set value. The governor is set for a specific RPM via the cockpit propeller control, that compresses or releases the governor speeder spring.
- (2) When the engine is operating at the RPM set by the pilot using the cockpit control, the governor is operating **onspeed**. Refer to Figure 2-10. In an onspeed condition, the centrifugal force acting on the flyweights is balanced by the speeder spring, and the pilot valve is neither directing oil to nor from the propeller hydraulic cylinder.
- (3) When the engine is operating below the RPM set by the pilot using the cockpit control, the governor is operating **underspeed**. Refer to Figure 2-11. In an underspeed condition, the flyweights tilt inward because there is not enough centrifugal force on the flyweights to overcome the force of the speeder spring. The pilot valve, forced down by the speeder spring, meters oil flow to decrease propeller pitch and raise engine RPM.
- (4) When the engine is operating above the RPM set by the pilot using the cockpit control, the governor is operating **overspeed**. Refer to Figure 2-12. In an overspeed condition, the centrifugal force acting on the flyweights is greater than the speeder spring force. The flyweights tilt outward, and raise the pilot valve. The pilot valve then meters oil flow to increase propeller pitch and lower engine RPM.

APS6152

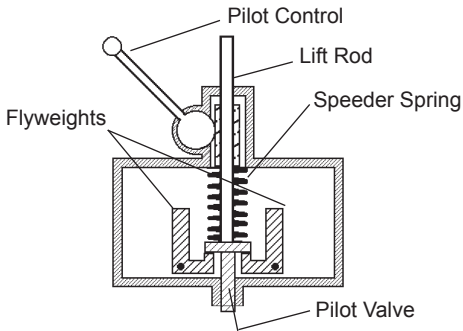

**Feathering Governor
Figure 2-13**

APS6153

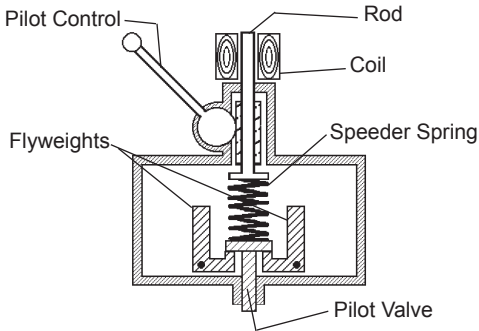

**Synchronizer/Synchrophaser Governor
Figure 2-14**

- (5) Feathering governors allow oil to be pushed from the propeller to the engine drain to increase propeller pitch to feather.

Some governors will move the propeller to feather by actuating a valve that opens to drain the oil supply between the propeller and governor.

Figure 2-13 illustrates another feathering propeller governor system. When it is desired to feather the propeller, the lift rod may be moved by the cockpit control to mechanically engage the valve. The lifted valve dumps oil to increase propeller pitch until the propeller feathers.

- (6) A synchronizing system can be employed in a multi-engine aircraft to keep the engines operating at the same RPM. A synchrophasing system not only keeps the RPM of the engines consistent, but also keeps the propeller blades in phase with each other. Both synchronizing and synchrophasing systems serve to reduce noise and vibration.

Synchrophasers installed with turbine propellers generate an electromagnetic field, either on the rod, or the flyweights. Figure 2-14 illustrates a governor as a component of a synchronizing or synchrophasing system that generates an electromagnetic field on the rod.

4. Propeller Ice Protection Systems

A Hartzell Propeller Inc. turbine propeller may be equipped with an anti-ice or de-ice system. A short description of each of these systems follows:

A. Propeller Anti-ice System

A propeller anti-ice system is a system that prevents ice from forming on propeller surfaces. The system dispenses a liquid (usually isopropyl alcohol) which mixes with moisture on the propeller blades, reducing the freezing point of the water. This water/alcohol mixture flows off the blades before ice forms. This system must be in use before ice forms. It is ineffective in removing ice that has already formed.

(1) System Overview

- (a) A typical anti-ice system consists of a fluid tank, pump, and distribution tubing.
- (b) The rate at which the anti-icing fluid is dispensed is controlled by a pump speed rheostat in the cockpit.
- (c) The anti-icing fluid is dispensed through airframe mounted distribution tubing and into a rotating slinger ring mounted on the rear of the propeller hub. The anti-icing fluid is then directed through blade feed tubes from the slinger ring onto the blades via centrifugal force. The anti-icing fluid is directed onto anti-icing boots that are attached to the leading edge of the blade. These anti-icing boots evenly distribute and direct the fluid along the blade leading edge.

B. Propeller De-ice System

A propeller de-ice system is a system that allows ice to form, and then removes it by electrically heating the de-ice boots. The ice partially melts and is thrown from the blade by centrifugal force.

(1) System Overview

- (a) A de-ice system consists of one or more on/off switches, a timer or cycling unit, a slip ring and brush blocks, and de-ice boots. The pilot controls the operation of the de-ice system by turning on one or more switches. All de-ice systems have a master switch, and may have another toggle switch for each propeller. Some systems also have a selector switch to adjust for light or heavy icing conditions.
- (b) The timer or cycling unit determines the sequence of which blades (or portion thereof) are currently being de-iced, and for what length of time. The cycling unit applies power to each de-ice boot or boot segment in a sequential order.
- (c) A brush block, which is normally mounted on the engine just behind the propeller, is used to transfer electricity to the slip ring. The slip ring rotates with the propeller, and provides a current path to the blade de-ice boots.
- (d) De-ice boots contain internal heating elements. These boots are securely attached to the leading edges of each blade with adhesive.

(This page is intentionally blank.)

INSTALLATION AND REMOVAL - CONTENTS

1. Tools, Consumables, and Expendables	3-3
A. Tooling	3-3
B. Consumables	3-4
C. Expendables	3-4
2. Pre-Installation	3-5
A. Inspection of Shipping Package	3-5
B. Uncrating	3-5
C. Inspection after Shipment	3-5
D. Reassembly of a Propeller Disassembled for Shipment.....	3-5
3. Propeller Assembly Installation	3-6
A. Precautions	3-6
B. Installing HC-B(3, 5)()(-2() Propeller on the Aircraft Engine	3-7
C. Installing HC-B(3,4,5)()(A,N,P)-3() Propeller on the Aircraft Engine	3-14
D. Installing HC-B(3,4)()W-3() Propeller on the Aircraft Engine	3-20
E. Installing HC-B(3,4)()(-5() Propeller, with a One-piece Spinner Mounting Plate, on the Aircraft Engine	3-31
F. Installing HC-B(3,4,5)()(-5() Propeller, with a Two-piece Spinner Mounting Plate, on the Aircraft Engine	3-35
G. Installing HC-()3()(-7() Propeller on the Allison Engine	3-40
4. Spinner Dome Installation	3-50
5. Post-Installation Checks	3-50
6. Spinner Dome Removal	3-51
7. Propeller Assembly Removal	3-52
A. Removal of HC-B(3,5)()(-2() Propellers	3-52
B. Removal of HC-B(3,4,5)()(A,N,P)-3() Propellers	3-55
C. Removal of HC-B(3,4)()W-3() Propellers	3-59
D. Removal of HC-B(3,4,5)()(-5() Propellers	3-62
E. Removal of HC-()3()(-7() Propellers	3-65
F. Removal of Beta Valve Assembly for HC-()3()(-7() Propellers	3-68

INSTALLATION AND REMOVAL - FIGURES

Mounting Bolt and Washer	Figure 3-1	3-9
Installing Propeller on Engine Flange.....	Figure 3-2	3-10
Diagram of Torquing Sequence for Propeller Mounting Bolts.....	Figure 3-3	3-11
Determining Torque Value When Using Torquing Adaptor.....	Figure 3-4	3-13
Beta System Puller for Decompressing -3 Series External Beta System.....	Figure 3-5	3-16
Carbon Block and Beta Ring Clearance.....	Figure 3-6	3-18
Carbon Block Assembly.....	Figure 3-7	3-18
Hub-to-Spacer O-ring Location in the Spacer.....	Figure 3-8	3-22
Installing the HC-B(3,4)()W-3() Propeller on the Engine Flange.....	Figure 3-9	3-24
Installing the Washer on the Mounting Stud..	Figure 3-10	3-26
One-piece Spinner Mounting Plate Installation.....	Figure 3-11	3-30
Beta Valve System	Figure 3-12	3-38
Cross Section View of the Beta Valve System.....	Figure 3-13	3-39
-7() Propeller Assembly	Figure 3-14	3-42
Spring Assembly to Cylinder Attachment Details.....	Figure 3-15	3-43
Piston to Link Arm Attachment Details.....	Figure 3-16	3-43
Filed Rod for Set Screw.....	Figure 3-17	3-48

INSTALLATION AND REMOVAL - TABLES

Propeller/Engine Flange O-rings.....	Table 3-1	3-8
Propeller Mounting Hardware.....	Table 3-2	3-8
Torque Table	Table 3-3	3-12

1. Tools, Consumables, and Expendables

The following tools, consumables, and expendables will be required for propeller removal or installation:

A. Tooling

Each propeller model requires a calibrated torque wrench, safety wire pliers (alternate: safety cable tool), and the model specific tooling listed below:

HC-B3()(A,N,P)-2()

- Torque wrench adaptor (Hartzell Propeller Inc. P/N AST-2877)
- 5/8 inch deep well socket
- 1-7/16 inch crowfoot wrench

HC-B(3,4,5)()(A,N,P)-3()

- Torque wrench adaptor (Hartzell Propeller Inc. P/N AST-2877)
- 5/8 inch deep well socket
- 1-7/16 inch crowfoot wrench
- Feeler gage
- Beta system puller (Hartzell Propeller Inc. P/N CST-2987)

HC-B(3,4)()W-3()

- Torque wrench adaptor (Hartzell Propeller Inc. P/N AST-3175)
- Torque check tool (Hartzell Propeller Inc. P/N AST-2968-1)
- Feeler gage
- Beta system puller (Hartzell Propeller Inc. P/N CST-2987)
- 5/8 inch deep well socket
- 1-7/16 inch crowfoot wrench

HC-B5M()-2**HC-B(3,4,5)()-5()**

- Torque wrench adaptor (Hartzell Propeller Inc. P/N AST-2877)
- One inch deep well socket
- 1-13/16 inch crowfoot wrench

HC-()3()F-7()

- Torque wrench adaptor (Hartzell Propeller Inc. P/N AST-2917)
 - 5/8 inch deep well socket
 - 1-7/16 inch crowfoot wrench
- B. Consumables
- Quick Dry Stoddard Solvent or Methyl-Ethyl-Ketone (MEK)
 - Anti-Seize Compound (MIL-PRF-83483)
- C. Expendables
- 0.032 inch (0.81 mm) Stainless Steel Aircraft Safety Wire (Alternate: 0.032 inch [0.81 mm] aircraft safety cable and associated hardware)
 - O-ring, propeller flange (see Table 3-1)
 - O-ring, for HC-B(3,4)()W-3() spacer (see Table 3-1)

2. Pre-Installation**A. Inspection of Shipping Package**

Examine the exterior of the shipping container for signs of shipping damage, especially at the box ends around each blade. A hole, tear, or crushed appearance at the end of the box (blade tips) may indicate the propeller was dropped during shipment, possibly damaging the blades.

B. Uncrating

- (1) Place the propeller on a firm support.
- (2) Remove the banding and any external wood bracing from the shipping container.
- (3) Remove the cardboard from the hub and blades. Place the propeller on a padded surface that supports the propeller over a large area. Never stand the propeller on a blade tip.
- (4) Remove the plastic dust cover cup from the propeller mounting flange (if installed).

C. Inspection after Shipment

After removing the propeller from the shipping container, examine the propeller components for shipping damage.

CAUTION: TO FACILITATE BOXING AND SHIPPING OF PROPELLERS, THE PISTON NUT (A-880-1 OR -2) ON STEEL HUB TURBINE PROPELLERS MAY BE REMOVED TO ALLOW ROTATING OF THE BLADES BEFORE PACKAGING.

NOTE: The ability to rotate the blades during propeller installation will allow easier access to the propeller mounting bolts on -3 propeller models.

D. Reassembly of a Propeller Disassembled for Shipment

If a propeller was received disassembled for shipment, it is to be reassembled by trained personnel in accordance with the applicable propeller maintenance manual.

3. Propeller Assembly Installation**A. Precautions**

WARNING 1: DURING ENGINE INSTALLATION OR REMOVAL, USING THE PROPELLER TO SUPPORT THE WEIGHT OF THE ENGINE IS NOT AUTHORIZED. UNAPPROVED INSTALLATION AND REMOVAL TECHNIQUES MAY CAUSE DAMAGE TO THE PROPELLER THAT MAY LEAD TO FAILURE RESULTING IN AN AIRCRAFT ACCIDENT.

WARNING 2: WHEN INSTALLING THE PROPELLER, FOLLOW THE AIRFRAME MANUFACTURER'S MANUALS AND PROCEDURES, AS THEY MAY CONTAIN ISSUES VITAL TO AIRCRAFT SAFETY THAT ARE NOT CONTAINED IN THIS OWNER'S MANUAL.

CAUTION 1: INSTRUCTIONS AND PROCEDURES IN THIS SECTION MAY INVOLVE CRITICAL PARTS. REFER TO THE INTRODUCTION CHAPTER OF THIS MANUAL FOR INFORMATION ABOUT PROPELLER CRITICAL PARTS. REFER TO THE ILLUSTRATED PARTS LIST CHAPTER OF THE APPLICABLE OVERHAUL MANUAL(S) FOR THE IDENTIFICATION OF SPECIFIC PROPELLER CRITICAL PARTS.

CAUTION 2: AVOID THE USE OF BLADE PADDLES. DO NOT PLACE THE BLADE PADDLE IN THE AREA OF THE DE-ICE BOOT WHEN APPLYING TORQUE TO A BLADE ASSEMBLY. PLACE THE BLADE PADDLE IN THE THICKEST AREA OF THE BLADE, JUST OUTSIDE OF THE DE-ICE BOOT. USE ONE BLADE PADDLE PER BLADE.

- (1) Be sure the propeller is removed before the engine is removed or installed in the airframe.

- (2) Follow the airframe manufacturer's instructions for installing the propeller. If such instructions are not in the airframe manufacturer's manual, then follow the instructions in this manual; however, mechanics must consider that this owner's manual does not describe important procedures that are outside the scope of this manual. In addition to propeller installation procedures, items such as rigging and preflight testing of flight idle blade angle, installation and adjustment of de-ice equipment, and propeller synchronization devices are normally found in the airframe manufacturer's manuals.

B. Installing HC-B(3, 5)()(-2() Propeller on the Aircraft Engine

WARNING: MAKE SURE THE SLING IS RATED UP TO 800 LBS (363 KG) TO SUPPORT THE WEIGHT OF THE PROPELLER ASSEMBLY DURING REMOVAL.

CAUTION 1: INSTRUCTIONS AND PROCEDURES IN THIS SECTION MAY INVOLVE CRITICAL PARTS. REFER TO THE INTRODUCTION CHAPTER OF THIS MANUAL FOR INFORMATION ABOUT PROPELLER CRITICAL PARTS. REFER TO THE ILLUSTRATED PARTS LIST CHAPTER OF THE APPLICABLE OVERHAUL MANUAL(S) FOR THE IDENTIFICATION OF SPECIFIC PROPELLER CRITICAL PARTS.

CAUTION 2: WHEN INSTALLING THE PROPELLER ON THE AIRCRAFT, DO NOT DAMAGE THE ICE PROTECTION SYSTEM COMPONENTS, IF APPLICABLE.

- (1) With a suitable crane hoist and sling, carefully move the propeller assembly to the aircraft engine mounting flange.
- (2) Make sure the propeller hub flange and engine flange mating surfaces are clean.

- (3) Install the specified O-ring on the engine flange. Refer to Table 3-1.
- (4) Align mounting and dowel pin holes in the propeller hub flange with the mounting holes and dowel pins in the engine flange.

CAUTION: MAKE SURE THAT COMPLETE AND TRUE SURFACE CONTACT IS ESTABLISHED BETWEEN THE PROPELLER HUB FLANGE AND THE ENGINE FLANGE.

- (5) Slide the propeller flange onto the engine flange.

Flange O-ring	Part Number
A flange	C-3317-239-2
F flange	C-3317-228
N/P flange	C-3317-230
W flange Hub-to-Engine	C-3317-230
HC-B(3,4)()W-3() Hub-to-Spacer	C-3317-233

**Propeller/Engine Flange O-rings
Table 3-1**

Propeller Model	Mounting Hardware
HC-B3TF-7()	A-1328-1 Bolt and A-1381 Washer
HC-B3()N-()	B-3339 Bolt and A-2048-2 Washer
HC-B(3,4)()W-3()	B-7458 Nut and B-7624 Washer
HC-B4()()-()	B-3339 Bolt and A-2048-2 Washer
HC-B5MA-()	B-3347 Bolt and A-2048-2 Washer
HC-B5MP-3()	B-3339 Bolt and A-2048-2 Washer
HC-B5MP-5()	B-3339-1 Bolt and A-2048-2 Washer

**Propeller Mounting Hardware
Table 3-2**

CAUTION: NEW PROPELLER MOUNTING BOLTS MUST BE USED WHEN INITIALLY INSTALLING A NEW OR OVERHAULED PROPELLER.

(6) Apply MIL-PRF-83483 anti-seize compound to the threaded surfaces of the specified mounting bolts. Refer to Table 3-2 for appropriate mounting hardware.

(a) If the propeller is removed between overhaul intervals, mounting bolts and washers may be reused if they are not damaged or corroded.

CAUTION: ID CHAMFER OF WASHER MUST BE FACING TOWARD THE BOLT HEAD. WASHERS WITHOUT CHAMFER MUST BE INSTALLED WITH ROLLED EDGES TOWARD THE BOLT HEAD. (REFER TO FIGURE 3-1).

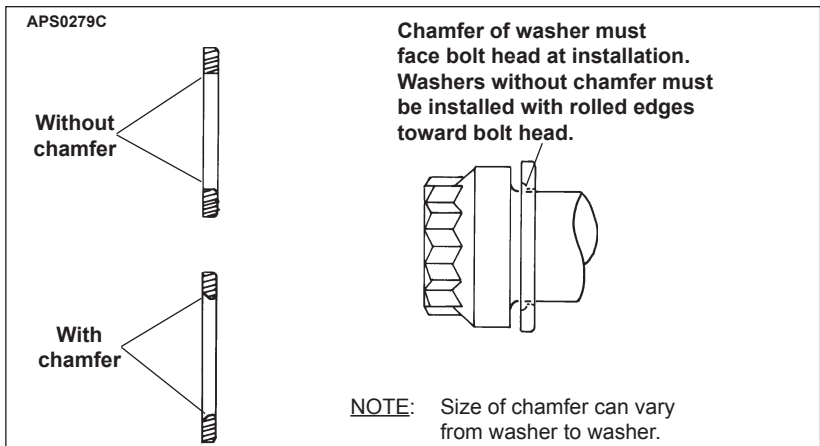

Mounting Bolt and Washer
Figure 3-1

3040I.TIF
W10077
W10078
W10079
W10080

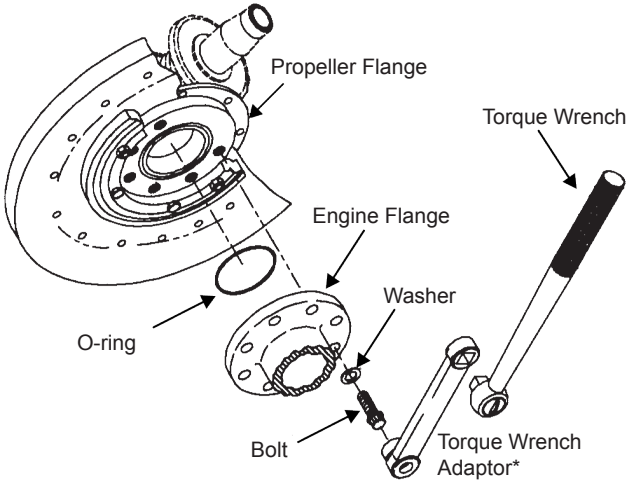

*Note: If torque wrench adaptor is used, use the calculation in Figure 3-4 to determine correct torque wrench setting.

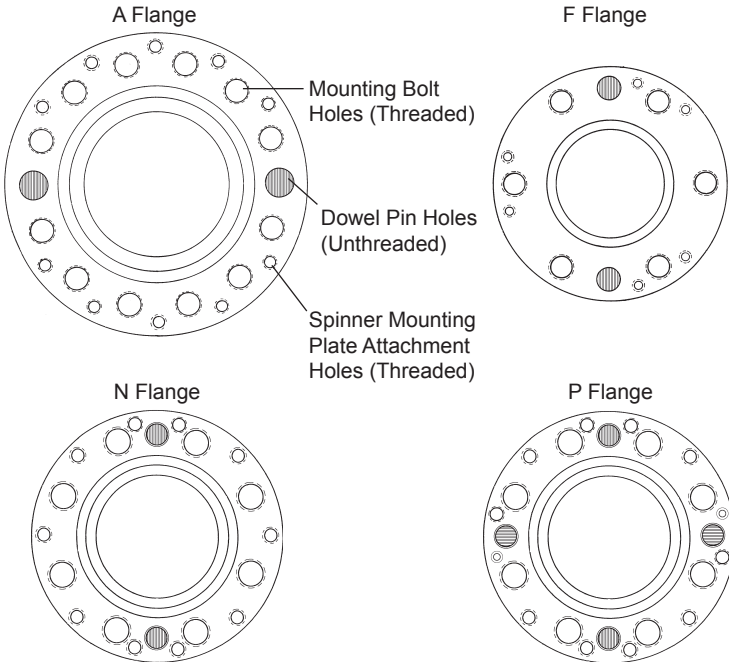

**Installing Propeller on Engine Flange
Figure 3-2**

W10107C
W10107B
W10106C
W10109C
W10109B

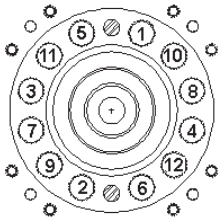

SEQUENCE A

A Flange

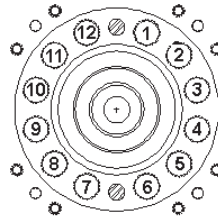

SEQUENCE B

Use Sequence A for steps one and two. Use Sequence B for step three.

Step 1 - Torque all bolts to 40 ft-lbs (54 N•m). Step 3 - Torque all bolts to
Step 2 - Torque all bolts to 80 ft-lbs (108 N•m). Table 3-3.

F Flange

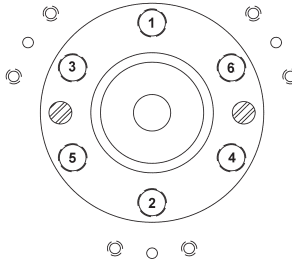

Step 1 - Torque all bolts to 40 ft-lbs (54 N•m).
Step 2 - Torque all bolts to Table 3-3.

N, P or W Flange

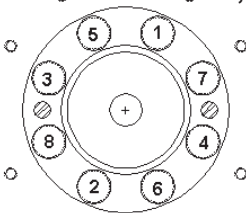

SEQUENCE A

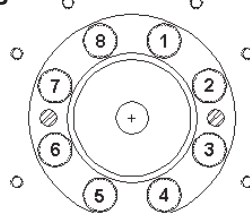

SEQUENCE B

Use Sequence A for steps one and two. Use Sequence B for step three.

Step 1 - Torque all bolts to 40 ft-lbs (54 N•m). Step 3 - Torque all bolts to
Step 2 - Torque all bolts to 80 ft-lbs (108 N•m). Table 3-3.

**Diagram of Torquing Sequence for Propeller Mounting Bolts
Figure 3-3**

- (7) Install the mounting bolts with washers through the engine flange and into the propeller hub flange. Refer to Figure 3-2.
- (8) Use a torque wrench and the specified torque wrench adaptor (see paragraph 1.A. Tooling in this chapter) to torque all mounting bolts in sequences and steps shown in Figure 3-3. Refer to Table 3-3 and Figure 3-4 to determine the proper torque value.
- (9) Safety all mounting bolts with 0.032 inch (0.81 mm) minimum diameter stainless steel wire or equivalent aircraft safety cable and associated hardware (two bolts per safety.)

CAUTION: TO FACILITATE BOXING AND SHIPPING OF PROPELLERS, THE PISTON NUT (A-880-1) ON HC-B3() ()-2() STEEL HUB TURBINE PROPELLERS MAY HAVE BEEN REMOVED TO ALLOW ROTATING OF THE BLADES BEFORE PACKAGING.

A flange mounting bolts	100-105 Ft-Lbs (136-142 N•m) wet
F flange mounting bolts	80-90 Ft-Lbs (108-122 N•m)
N/P flange mounting bolts	100-105 Ft-Lbs (136-142 N•m) wet
W flange mounting nuts	120-125 Ft-Lbs (163-170 N•m)
Spinner mounting bolts	30-40 Ft-Lbs (41-54 N•m)
Piston nut (lock nut)	120 Ft-Lbs (163 N•m)*
Guide rod jam nuts	10 Ft-Lbs (14 N•m)*
Lubrication Fitting	4 Ft-Lbs (5 N•m)*
Check Nut (beta valve assembly)	9-11 Ft-Lbs (12-15 N•m)

* Torque tolerance is ± 10 percent unless otherwise noted.

NOTE 1: Torque values are based on non-lubricated threads, unless otherwise specified.

NOTE 2: Wet torque values denote the use of anti-seize compound MIL-PRF-83483.

**Torque Table
Table 3-3**

- (10) Procedure for reinstallation of piston nut, if applicable.
- Following the installation of the propeller, use a breaker bar and a 5/8 inch deep well socket to hold the pitch change rod.
 - Using a 1- 7/16 inch crowfoot wrench and torque wrench, torque the A-880-1 piston nut. Refer to Table 3-3 and Figure 3-4 for the proper torque value.

NOTE: The removal and subsequent reinstallation of the piston nut does not require that the propeller blade angles be re-checked.

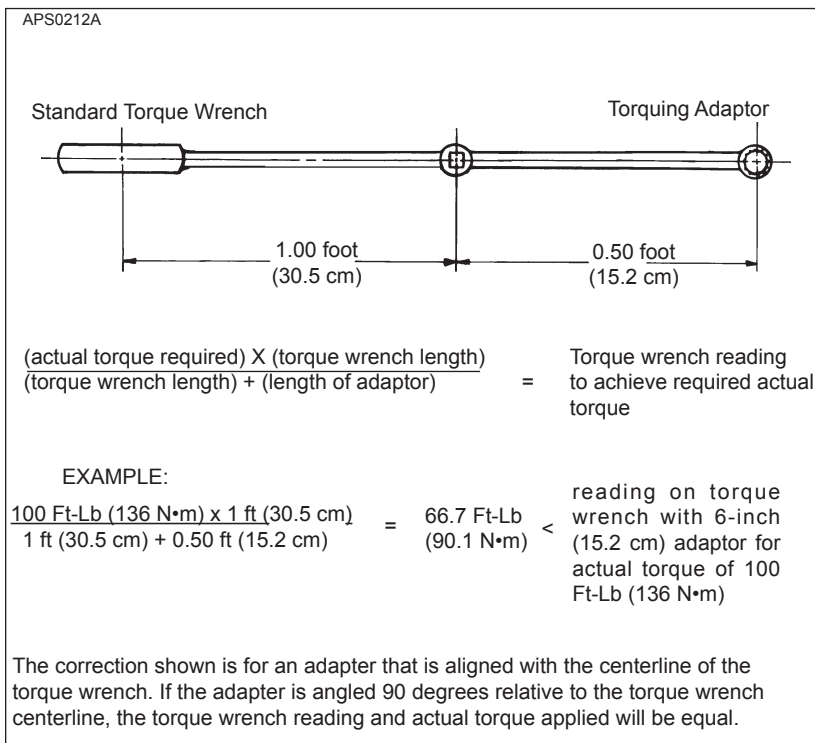

**Determining Torque Value When Using Torquing Adaptor
Figure 3-4**

- (11) If the propeller is equipped with an ice protection system that uses components supplied by Hartzell Propeller Inc., applicable instructions and technical information for the components supplied by Hartzell Propeller Inc. can be found in the following publications available on the Hartzell Propeller Inc. website at www.hartzellprop.com:
- (a) Manual 180 (30-61-80) - Propeller Ice Protection System Manual
 - (b) Manual 181 (30-60-81) - Propeller Ice Protection System Component Maintenance Manual
 - (c) Manual 182 (61-12-82) - Propeller Electrical De-ice Boot Removal and Installation Manual
 - (d) Manual 183 (61-12-83) - Propeller Anti-icing Boot Removal and Installation Manual
- (12) Propeller ice protection system components not supplied by Hartzell Propeller Inc. are controlled by the applicable TC or STC holder's Instructions for Continued Airworthiness (ICA).
- C. Installing HC-B(3,4,5)() (A,N,P)-3() Propeller on the Aircraft Engine

CAUTION: INSTRUCTIONS AND PROCEDURES IN THIS SECTION MAY INVOLVE CRITICAL PARTS. REFER TO THE INTRODUCTION CHAPTER OF THIS MANUAL FOR INFORMATION ABOUT PROPELLER CRITICAL PARTS. REFER TO THE ILLUSTRATED PARTS LIST CHAPTER OF THE APPLICABLE OVERHAUL MANUAL(S) FOR THE IDENTIFICATION OF SPECIFIC PROPELLER CRITICAL PARTS.

NOTE: The use of a fretting disk between the propeller flange and engine flange is recommended on certain applications for propeller models HC-B5MP-3(). Refer to Hartzell Propeller Inc. Service Bulletin HC-SB-61-275 information about affected applications.

- (1) Use a beta system puller CST-2987 (Figure 3-5) to compress the beta system and pull the beta ring forward to allow installation of the double hex head propeller mounting bolts.

WARNING: MAKE SURE THE SLING IS RATED UP TO 800 LBS (363 KG) TO SUPPORT THE WEIGHT OF THE PROPELLER ASSEMBLY DURING INSTALLATION.

CAUTION: WHEN INSTALLING THE PROPELLER ON THE AIRCRAFT, DO NOT DAMAGE THE ICE PROTECTION SYSTEM COMPONENTS, IF APPLICABLE.

- (2) With a suitable crane hoist and sling, carefully move the propeller assembly to the aircraft engine mounting flange.
- (3) Make sure the propeller hub flange and the engine flange mating surfaces are clean.
- (4) Install the specified O-ring on the engine flange. Refer to Table 3-1.
- (5) Align the mounting and dowel pin holes in the propeller hub flange with the mounting holes and dowel pins in the engine flange.

CAUTION: MAKE SURE THAT COMPLETE AND TRUE SURFACE CONTACT IS ESTABLISHED BETWEEN THE PROPELLER HUB FLANGE AND THE ENGINE FLANGE.

- (6) Slide the propeller flange onto the engine flange.

CAUTION: NEW PROPELLER MOUNTING BOLTS MUST BE USED WHEN INITIALLY INSTALLING A NEW OR OVERHAULED PROPELLER.

- (7) Apply MIL-PRF-83483 anti-seize compound to the threaded surfaces of the specified mounting bolts. Refer to Table 3-2 for appropriate mounting hardware.

NOTE: If the propeller is removed between overhaul intervals, mounting bolts and washers may be reused if they are not damaged or corroded.

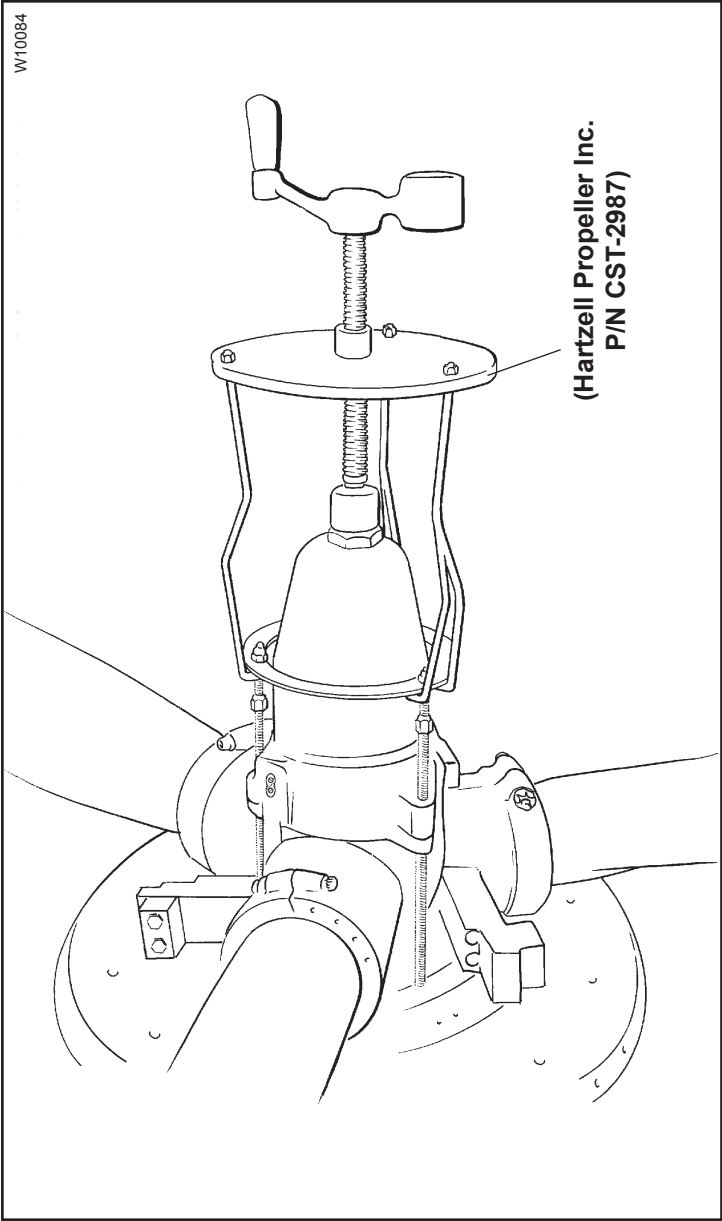

Beta System Puller for Decompressing -3 Series External Beta System
Figure 3-5

CAUTION: ID CHAMFER OF THE WASHER MUST BE FACING TOWARD THE BOLT HEAD. WASHERS WITHOUT CHAMFER MUST BE INSTALLED WITH ROLLED EDGES TOWARD THE BOLT HEAD. (REFER TO FIGURE 3-1).

- (8) Install mounting bolts with washers through the engine flange and into the propeller hub flange. Refer to Figure 3-2.
- (9) Use a torque wrench and the specified torque wrench adaptor (see paragraph 1.A. Tooling in this chapter) to torque all mounting bolts in sequences and steps shown in Figure 3-3. Refer to Table 3-3 and Figure 3-4 to determine the proper torque value.
- (10) Safety all mounting bolts with 0.032 inch (0.81 mm) minimum diameter stainless steel wire or equivalent aircraft safety cable and associated hardware (two bolts per safety).
- (11) Decompress the external beta system and remove the beta system puller.

CAUTION: THE BETA RING MUST NOT CONTACT ANY ENGINE COMPONENT OR MOUNTING BOLT SAFETY WIRE. THE BETA SYSTEM COULD BE DAMAGED IF IT CONTACTS ANY STATIC ENGINE COMPONENT WHILE ROTATING.

- (12) Examine the beta ring to make sure that it is not in contact with any engine component or mounting bolt safety wire.
 - (a) If there is contact between the beta ring and any engine component or mounting bolt safety wire, consult qualified personnel at an appropriately licensed propeller repair facility.
- (13) Install the carbon block into the beta linkage lever in accordance with the airframe manufacturer's instructions.

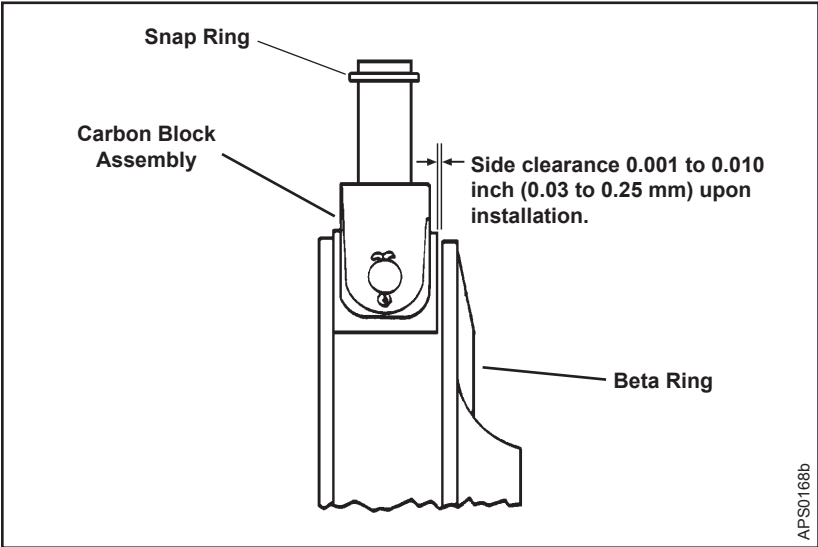

APSO168b

Carbon Block and Beta Ring Clearance
Figure 3-6

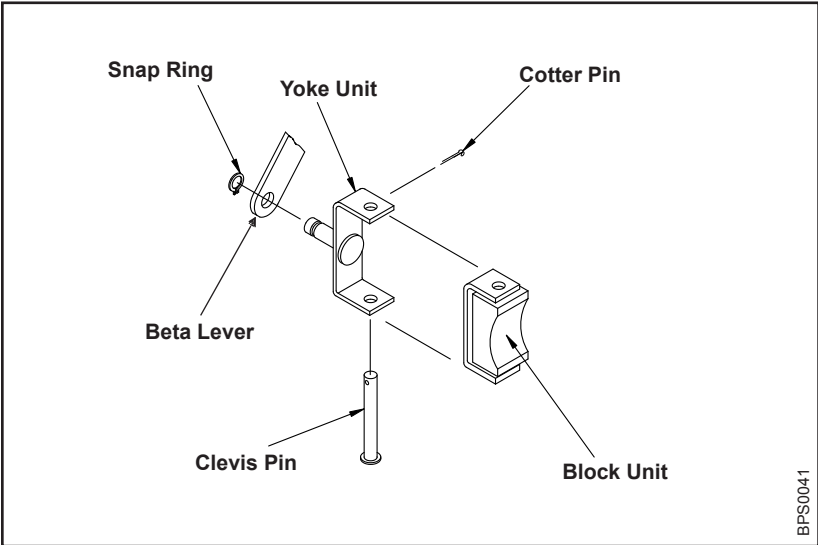

BPS0041

Carbon Block Assembly
Figure 3-7

CAUTION 1: FIT THE BLOCK IN THE BETA RING WITH A MINIMUM SIDE CLEARANCE OF 0.001 INCH (0.03 mm). REFER TO FIGURE 3-6.

CAUTION 2: MAXIMUM SIDE CLEARANCE PERMITTED IS 0.010 INCH (0.25 mm) IN ACCORDANCE WITH THE CARBON BLOCK ASSEMBLIES SECTION IN THE MAINTENANCE PRACTICES CHAPTER OF THIS MANUAL.

█ (14) Install the carbon block assembly (Figure 3-7) into the beta ring.

█ (15) Install, adjust and safety the beta linkage per the airframe manufacturer's instructions.

CAUTION: TO FACILITATE BOXING AND SHIPPING OF PROPELLERS, THE PISTON NUT MAY HAVE BEEN REMOVED TO ALLOW ROTATING OF THE BLADES BEFORE PACKAGING.

█ (16) Procedure for reinstallation of piston nut, if applicable.

(a) Following the installation of the propeller, use a breaker bar and a 5/8 inch deep well socket to hold the pitch change rod.

(b) Using a 1-7/16 inch crowfoot wrench and torque wrench, torque the A-880-1 piston nut. Refer to Table 3-3 and Figure 3-4 for the proper torque value.

NOTE: The removal and subsequent reinstallation of the piston nut does not require that the propeller blade angles be re-checked.

█ (17) If the propeller is equipped with an ice protection system that uses components supplied by Hartzell Propeller Inc., applicable instructions and technical information for the components supplied by Hartzell Propeller Inc. can be found in the following publications available on the Hartzell Propeller Inc. website at www.hartzellprop.com:

█ (a) Manual 180 (30-61-80) - Propeller Ice Protection System Manual

- (b) Manual 181 (30-60-81) - Propeller Ice Protection System Component Maintenance Manual
 - (c) Manual 182 (61-12-82) - Propeller Electrical De-ice Boot Removal and Installation Manual
 - (d) Manual 183 (61-12-83) - Propeller Anti-icing Boot Removal and Installation Manual
- (18) Propeller ice protection system components not supplied by Hartzell Propeller Inc. are controlled by the applicable TC or STC holder's Instructions for Continued Airworthiness (ICA).
- D. Installing HC-B(3,4)()W-3() Propeller on the Aircraft Engine

CAUTION 1: INSTRUCTIONS AND PROCEDURES IN THIS SECTION MAY INVOLVE CRITICAL PARTS. REFER TO THE INTRODUCTION CHAPTER OF THIS MANUAL FOR INFORMATION ABOUT PROPELLER CRITICAL PARTS. REFER TO THE ILLUSTRATED PARTS LIST CHAPTER OF THE APPLICABLE OVERHAUL MANUAL(S) FOR THE IDENTIFICATION OF SPECIFIC PROPELLER CRITICAL PARTS.

CAUTION 2: WHEN INSTALLING THE HC-B4TW-3/T10282N PROPELLER ON THRUSH AIRCRAFT MODELS S2R-H80 OR S2RHG-H80, COMPLIANCE WITH GE AVIATION SERVICE BULLETIN H80-100-72-00019 IS REQUIRED.

- (1) Use a beta system puller CST-2987 (Figure 3-5) to compress the beta system and pull the beta ring forward to allow access to the propeller mounting flange.

WARNING: MAKE SURE THE SLING IS RATED UP TO 800 LBS (363 KG) TO SUPPORT THE WEIGHT OF THE PROPELLER ASSEMBLY DURING INSTALLATION.

CAUTION: WHEN INSTALLING THE PROPELLER ON THE AIRCRAFT, DO NOT DAMAGE THE ICE PROTECTION SYSTEM COMPONENTS, IF APPLICABLE.

- (2) With a suitable crane hoist and sling, carefully move the propeller assembly to the aircraft engine mounting flange.

CAUTION: IF THE PROPELLER IS REMOVED BETWEEN OVERHAUL INTERVALS, A TORQUE CHECK OF THE MOUNTING STUDS MUST BE PERFORMED.

- (3) Unless this is the first installation of a new, or newly overhauled propeller, perform a torque check of the propeller mounting studs as follows:
- (a) Thread the torque check tool AST-2968-1 onto each propeller mounting stud and torque to 35 ft-lbs (47.6 N•m).
 - (b) Visually inspect each stud for evidence of movement.
 - (c) Remove the torque check tool AST-2968-1 while visually inspecting each stud for evidence of movement.
 - (d) If any stud rotates due to either the tightening or removal of the torque check tool, all studs must be replaced. Refer to Hartzell Propeller Inc. Standard Practices Manual 202A (ATA 61-01-02) for stud replacement procedures.
- (4) Make sure the propeller hub flange and the engine flange mating surfaces are clean.
- (5) Install the specified O-ring on the engine flange. Refer to Table 3-1.
- (6) If the C-7364-2 spacer is attached to the propeller hub with screws, proceed to step 3.D.(8).

- (7) If the C-7364-2 spacer is not already installed on the propeller hub perform the following installation procedures:
- (a) If the hub flange does not have two 8-32 threaded holes to attach the spacer or, if two attachment screws were not provided, perform the following steps:
- 1 Coat the hub-to-spacer O-ring with grease. Refer to Table 3-1.
 - 2 Install the hub-to-spacer O-ring in the groove in the spacer that interfaces with the face of the hub flange. Refer to Figure 3-8.
 - 3 Align the mounting studs and dowel pin holes in the propeller hub flange with the mounting holes and dowel pins in the spacer.

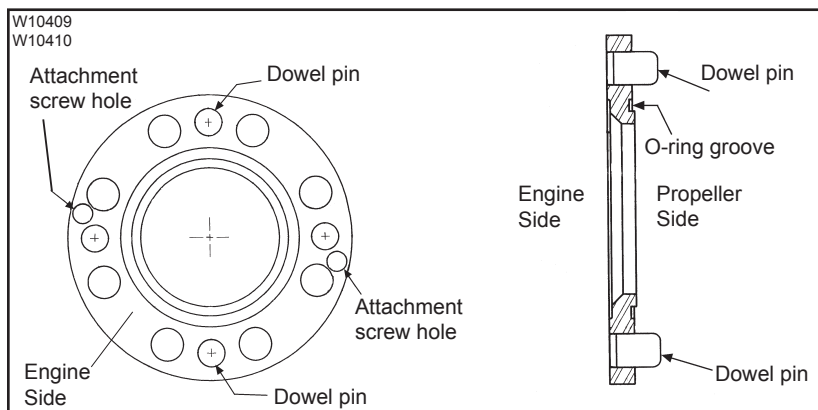

Hub-to-Spacer O-ring Location in the Spacer
Figure 3-8

CAUTION: MAKE SURE THE HUB-TO-SPACER O-RING STAYS IN THE GROOVE IN THE SPACER. IF THE O-RING IS TWISTED OR PINCHED, OIL LEAKAGE WILL RESULT WHEN THE PROPELLER IS OPERATED ON THE AIRCRAFT.

- 4** Slide the spacer onto the mounting studs and against the hub flange.

NOTE: If the propeller installation will be delayed, the spacer and O-ring should be installed and temporarily held in place with non-self locking nuts and a sufficient number of washers on at least two mounting studs. Remove the nuts and washers before installation.

- (b) If the hub flange has two 8-32 threaded holes and two MS24693-S2 flat-head screws (HPI P/N B-3868-S52) are provided to attach the C-7364-2 spacer, perform the following steps:

- 1** Coat the hub-to-spacer O-ring with grease. Refer to Table 3-1.
- 2** Install the hub-to-spacer O-ring in the groove in the spacer that interfaces with the face of the hub flange. Refer to Figure 3-8.
- 3** Align the spacer attachment holes with the two 8-32 threaded holes in the hub flange.

CAUTION: MAKE SURE THE HUB-TO-SPACER O-RING STAYS IN THE GROOVE IN THE SPACER. IF THE O-RING IS TWISTED OR PINCHED, OIL LEAKAGE WILL RESULT WHEN THE PROPELLER IS OPERATED ON THE AIRCRAFT.

- 4** Slide the spacer onto the mounting studs and against the hub flange.

APS6160C.TIF
E-7373i.PLT,
W10079

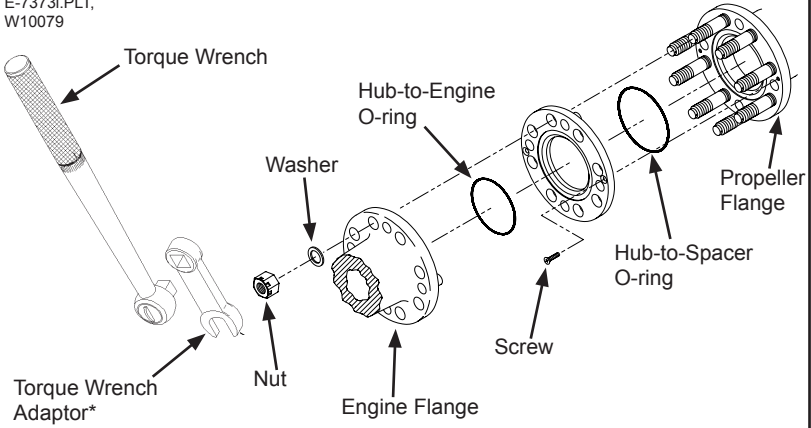

***Note:** If torque wrench adaptor is used, use the calculation in Figure 3-4 to determine correct torque wrench setting.

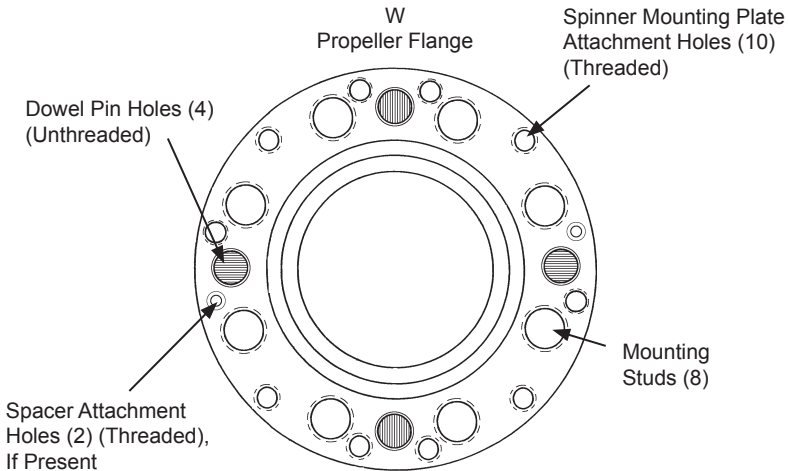

**Installing the HC-B(3,4)()W-3() Propeller on the Engine Flange
Figure 3-9**

- 5 Insert supplied flat-head screw through each screw hole in the spacer and into the 8-32 threaded holes in the hub flange. Refer to Figure 3-9.

CAUTION: MAKE SURE THE FLAT-HEAD ATTACHMENT SCREWS DO NOT PROTRUDE ABOVE THE ENGINE-SIDE SURFACE OF THE SPACER.

- 6 Tighten the flat-head screw until snug.
- 7 If after the flat-head screws are tightened, one or both are protrude above the engine side surface of the spacer, perform the following steps:
- a Remove both flat-head screws and the spacer.
 - b Rotate the spacer 180 degrees, aligning the screw holes in the spacer with the 8-32 threaded holes in the hub flange.

CAUTION: MAKE SURE THE FLAT-HEAD ATTACHMENT SCREWS DO NOT PROTRUDE ABOVE THE ENGINE-SIDE SURFACE OF THE SPACER.

- c Slide the spacer onto the mounting studs and against the hub flange.
- d Insert a flat-head screw through each screw hole in the spacer and into the 8-32 threaded holes in the hub flange. Refer to Figure 3-9.
- e Tighten the flat-head screw until snug.
- f If after the flat-head screws are tightened, one or both are protrude above the engine side surface of the spacer, remove the screws.

NOTE: If the propeller installation will be delayed, the spacer and O-ring should be installed and temporarily held in place with non-self locking nuts and a sufficient number of washers on at least two mounting studs. Remove the nuts and washers before installation.

CAUTION 1: MAKE SURE THAT COMPLETE AND TRUE SURFACE CONTACT IS ESTABLISHED BETWEEN THE SPACER AND THE ENGINE FLANGE.

CAUTION 2: IF THE C-7364-2 SPACER IS NOT ATTACHED TO THE HUB, MAKE SURE THE HUB-TO-SPACER O-RING STAYS IN THE GROOVE IN THE SPACER. IF THE O-RING IS TWISTED OR PINCHED, OIL LEAKAGE WILL RESULT WHEN THE PROPELLER IS OPERATED ON THE AIRCRAFT.

(8) Slide the propeller onto the engine flange.

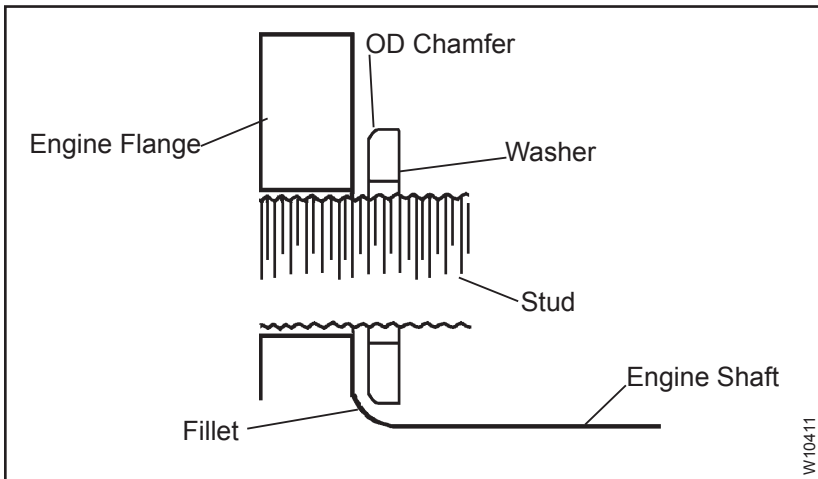

Installing the Washer on the Mounting Stud
Figure 3-10

CAUTION 1: NEW PROPELLER MOUNTING NUTS MUST BE USED WHEN INITIALLY INSTALLING A NEW OR OVERHAULED PROPELLER.

CAUTION 2: THE SIDE OF THE WASHER WITH THE OD CHAMFER MUST BE AGAINST THE ENGINE FLANGE. REFER TO FIGURE 3-10.

(9) Install self locking mounting nuts with washers onto the propeller mounting studs. Refer to Table 3-2 for appropriate mounting hardware. Refer to Figure 3-10.

NOTE 1: The OD chamfer on the washer is for clearance of the engine flange fillet. Refer to Figure 3-10.

NOTE 2: If the propeller is removed between overhaul intervals, mounting nuts and washers may be reused if they are not damaged or corroded.

(10) Use a torque wrench and the specified torque wrench adaptor (see paragraph 1.A. Tooling in this chapter) to torque all mounting nuts in the sequences and steps shown in Figure 3-3. Refer to Table 3-3 and Figure 3-4 to determine the proper torque value.

(11) Safety all propeller mounting studs with 0.032 inch (0.81 mm) minimum diameter stainless steel wire or equivalent aircraft safety cable and associated hardware (two bolts per safety.)

(12) Decompress the external beta system and remove the beta system puller.

CAUTION: THE BETA RING MUST NOT CONTACT ANY ENGINE COMPONENT OR MOUNTING BOLT SAFETY WIRE. THE BETA SYSTEM COULD BE DAMAGED IF IT CONTACTS ANY STATIC ENGINE COMPONENT WHILE ROTATING.

(13) Examine the beta ring to make sure that it is not in contact with any engine components or mounting bolt safety wire.

- (a) If there is contact between the beta ring and any engine components or mounting bolt safety wire, consult qualified personnel at an appropriately licensed propeller service facility.
- (14) Install the carbon block into the beta linkage lever per the airframe manufacturer's instructions.

CAUTION 1: FIT THE BLOCK IN THE BETA RING WITH A SIDE CLEARANCE OF 0.001 INCH (0.03 mm). REFER TO FIGURE 3-6.

CAUTION 2: MAXIMUM SIDE CLEARANCE PERMITTED IS 0.010 INCH (0.25 mm) IN ACCORDANCE WITH THE CARBON BLOCK ASSEMBLIES SECTION IN THE MAINTENANCE PRACTICES CHAPTER OF THIS MANUAL.

- (15) Install the carbon block assembly (Figure 3-7) into the beta ring.
- (16) Install, adjust and safety the beta linkage per the airframe manufacturer's instructions.

CAUTION: TO FACILITATE BOXING AND SHIPPING OF THE PROPELLER, THE PISTON NUT MAY HAVE BEEN REMOVED TO ALLOW ROTATING OF THE BLADES BEFORE PACKAGING.

- (17) Procedure for reinstallation of the piston nut, if applicable.
- (a) Following the installation of the propeller, use a breaker bar and a 5/8 inch deep well socket to hold the pitch change rod.
 - (b) Using a 1-7/16 inch crowfoot wrench and torque wrench, torque the A-880-1 piston nut. Refer to Table 3-3 and Figure 3-4 for the proper torque value.
- NOTE:** The removal and subsequent reinstallation of the piston nut does not require that the propeller blade angles be re-checked.

- (18) If the propeller is equipped with an ice protection system that uses components supplied by Hartzell Propeller Inc., applicable instructions and technical information for the components supplied by Hartzell Propeller Inc. can be found in the following publications available on the Hartzell Propeller Inc. website at www.hartzellprop.com:
- (a) Manual 180 (30-61-80) - Propeller Ice Protection System Manual
 - (b) Manual 181 (30-60-81) - Propeller Ice Protection System Component Maintenance Manual
 - (c) Manual 182 (61-12-82) - Propeller Electrical De-ice Boot Removal and Installation Manual
 - (d) Manual 183 (61-12-83) - Propeller Anti-icing Boot Removal and Installation Manual
- (19) Propeller ice protection system components not supplied by Hartzell Propeller Inc. are controlled by the applicable TC or STC holder's Instructions for Continued Airworthiness (ICA).

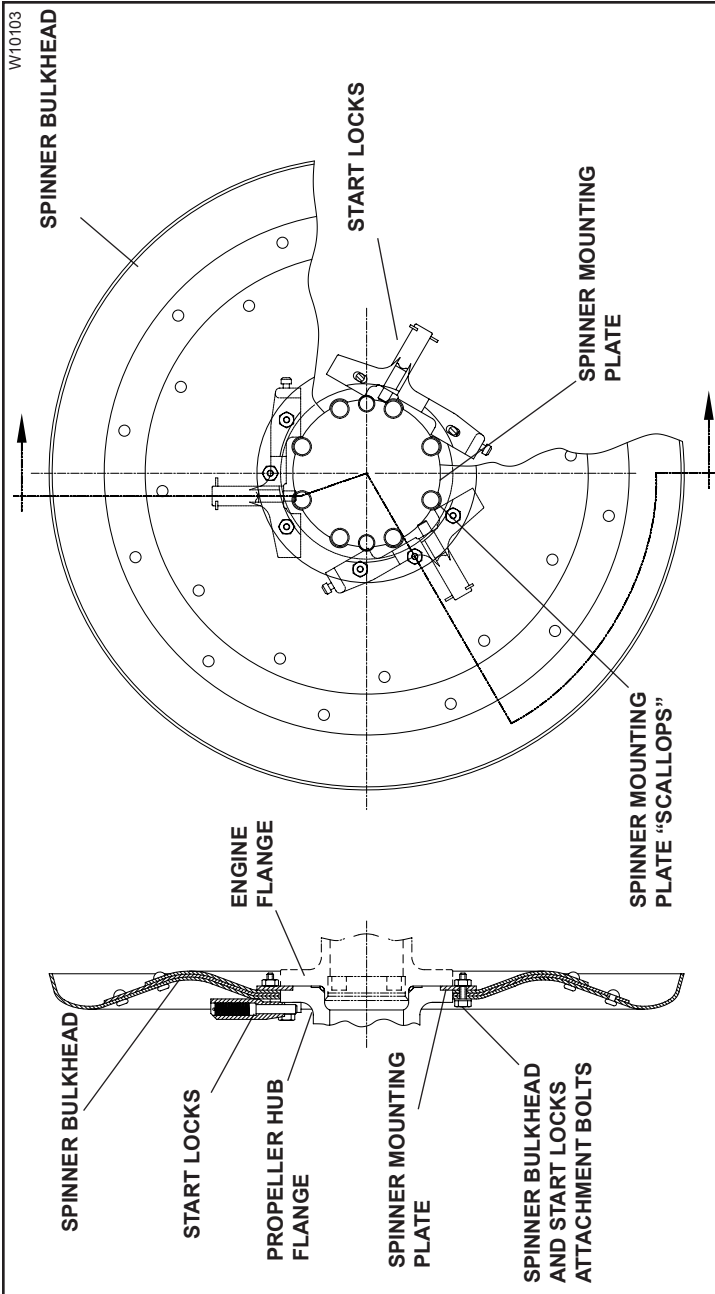

One-piece Spinner Mounting Plate Installation
Figure 3-11

- E. Installing HC-B(3,4)()(-5()) Propeller, with a One-piece Spinner Mounting Plate, on the Aircraft Engine

CAUTION: INSTRUCTIONS AND PROCEDURES IN THIS SECTION MAY INVOLVE CRITICAL PARTS. REFER TO THE INTRODUCTION CHAPTER OF THIS MANUAL FOR INFORMATION ABOUT PROPELLER CRITICAL PARTS. REFER TO THE ILLUSTRATED PARTS LIST CHAPTER OF THE APPLICABLE OVERHAUL MANUAL(S) FOR THE IDENTIFICATION OF SPECIFIC PROPELLER CRITICAL PARTS.

NOTE: Some -5 propellers were previously manufactured with a one-piece spinner mounting plate. The spinner bulkhead, which has start locks mounted on it, is attached to the spinner mounting plate. The spinner mounting plate is installed in a cutaway portion of the propeller hub flange and is “pinched” between the propeller hub flange and the engine flange. Refer to Figure 3-11.

WARNING: MAKE SURE THE SLING IS RATED UP TO 800 LBS (363 KG) TO SUPPORT THE WEIGHT OF THE PROPELLER ASSEMBLY DURING INSTALLATION.

CAUTION: WHEN INSTALLING THE PROPELLER ON THE AIRCRAFT, DO NOT DAMAGE THE ICE PROTECTION SYSTEM COMPONENTS, IF APPLICABLE.

- (1) With a suitable crane hoist and sling, carefully move the propeller assembly to the aircraft engine mounting flange.
- (2) Make sure the propeller hub flange and engine flange mating surfaces are clean.
- (3) Install the specified O-ring on the engine flange. Refer to Table 3-1.

- (4) Retract each start lock pin and hold into place with a heavy wire inserted into the hole in each auto high pitch housing.
- (5) Slide the assembled one-piece spinner mounting plate, spinner bulkhead and start lock onto the propeller hub flange.
 - (a) The start locks must face toward the propeller.
- (6) Align the clearance “scallops” in the spinner mounting plate with the holes in the propeller hub flange. Refer to Figure 3-11.

NOTE: This will insure that the spinner mounting plate does not interfere with the mounting bolts and dowel pins.

- (7) Align the start locks with each blade and clamp mounted stop plate.

NOTE: The start locks are attached to the spinner bulkhead.

- (8) Align mounting and dowel pin holes in the propeller hub flange with the mounting holes and dowel pins in the engine flange.

CAUTION: MAKE SURE THAT COMPLETE AND TRUE SURFACE CONTACT IS ESTABLISHED BETWEEN THE PROPELLER HUB FLANGE AND THE ENGINE FLANGE.

- (9) Slide the propeller flange onto the engine flange.

CAUTION: NEW PROPELLER MOUNTING BOLTS MUST BE USED WHEN INITIALLY INSTALLING A NEW OR OVERHAULED PROPELLER.

- (10) Apply MIL-PRF-83483 anti-seize compound to the threaded surfaces of the mounting bolts. Refer to Table 3-2 for appropriate mounting hardware.

NOTE: If the propeller is removed between overhaul intervals, mounting bolts and washers may be reused if they are not damaged or corroded.

CAUTION: ID CHAMFER OF THE WASHER MUST BE FACING TOWARD THE BOLT HEAD. WASHERS WITHOUT CHAMFER MUST BE INSTALLED WITH ROLLED EDGES TOWARD THE BOLT HEAD (FIGURE 3-1).

- (11) Install the mounting bolts with washers through the engine flange and into the propeller hub flange. Refer to Figure 3-2.
- (12) Use a torque wrench and the specified torque wrench adaptor (see paragraph 1.A. Tooling in this chapter) to torque all mounting bolts in sequences and steps shown in Figure 3-3. Refer to Table 3-3 and Figure 3-4 to determine the proper torque value.
- (13) Safety all mounting bolts with 0.032 inch (0.81 mm) minimum diameter stainless steel wire or equivalent aircraft safety cable and associated hardware (two bolts per safety.)
- (14) Remove the heavy wire from the start lock housings to free the start lock pins.
- (15) Refer to the airframe manufacturer's instructions to seat the start lock plates on the start locks.

NOTE: The start lock plates interface with the start lock pins and are attached to the inboard surface of each blade clamp.

CAUTION: TO FACILITATE BOXING AND SHIPPING OF PROPELLERS, THE PISTON NUT (A-880-2) ON -5 STEEL HUB TURBINE PROPELLERS MAY HAVE BEEN REMOVED TO ALLOW ROTATING OF THE BLADES BEFORE PACKAGING.

- (16) Procedure for reinstallation of piston nut, if applicable.
 - (a) Following the installation of the propeller, use a breaker bar and a one inch deep well socket to hold the pitch change rod.

- (b) Using a 1-13/16 inch crowfoot wrench and torque wrench, torque the A-880-2 piston nut. Refer to Table 3-3 and Figure 3-4 for the proper torque value.

NOTE: The removal and subsequent reinstallation of the piston nut does not require that the propeller blade angles be re-checked.

- (17) Install the beta tube per airframe and/or engine manufacturer's instructions.

NOTE 1: Follow the airframe manufacturer's instructions for adjusting the beta tube to obtain the correct low pitch (flight idle blade angle).

NOTE 2: Refer to the Aircraft Type Certificate Data Sheet for the low pitch blade angle setting.

- (18) If the propeller is equipped with an ice protection system that uses components supplied by Hartzell Propeller Inc., applicable instructions and technical information for the components supplied by Hartzell Propeller Inc. can be found in the following publications available on the Hartzell Propeller Inc. website at www.hartzellprop.com:

- (a) Manual 180 (30-61-80) - Propeller Ice Protection System Manual
- (b) Manual 181 (30-60-81) - Propeller Ice Protection System Component Maintenance Manual
- (c) Manual 182 (61-12-82) - Propeller Electrical De-ice Boot Removal and Installation Manual
- (d) Manual 183 (61-12-83) - Propeller Anti-icing Boot Removal and Installation Manual

- (19) Propeller ice protection system components not supplied by Hartzell Propeller Inc. are controlled by the applicable TC or STC holder's Instructions for Continued Airworthiness (ICA).

- F. Installing HC-B(3,4,5)()(-5() Propeller, with a Two-piece Spinner Mounting Plate, on the Aircraft Engine

CAUTION: INSTRUCTIONS AND PROCEDURES IN THIS SECTION MAY INVOLVE CRITICAL PARTS. REFER TO THE INTRODUCTION CHAPTER OF THIS MANUAL FOR INFORMATION ABOUT PROPELLER CRITICAL PARTS. REFER TO THE ILLUSTRATED PARTS LIST CHAPTER OF THE APPLICABLE OVERHAUL MANUAL(S) FOR THE IDENTIFICATION OF SPECIFIC PROPELLER CRITICAL PARTS.

NOTE: Some -5 propellers are manufactured with a two-piece spinner mounting plate which is bolted on the propeller hub flange. On four and five-blade propellers (see Figure 2-7) the bulkhead and start locks are attached to the spinner mounting plate. On three-bladed propellers (see Figure 2-6) the start locks are attached to the guide collar (between the hub and cylinder); although the bulkhead is attached to the spinner mounting plate.

WARNING: MAKE SURE THE SLING IS RATED UP TO 800 LBS (363 KG) TO SUPPORT THE WEIGHT OF THE PROPELLER ASSEMBLY DURING INSTALLATION.

CAUTION: WHEN INSTALLING THE PROPELLER ON THE AIRCRAFT, DO NOT DAMAGE THE ICE PROTECTION SYSTEM COMPONENTS, IF APPLICABLE.

- (1) With a suitable crane hoist and sling, carefully move the propeller assembly to the aircraft engine mounting flange.
 - (a) If the propeller is equipped with a de-ice system, refer to the General Maintenance Practices section in the Introduction chapter of this manual.

- (2) Make sure the propeller hub flange and engine flange mating surfaces are clean.
- (3) Install the specified O-ring on the engine flange. Refer to Table 3-1.
- (4) Align the mounting and dowel pin holes in the propeller hub flange with the mounting holes and dowel pins in the engine flange.

CAUTION: MAKE SURE THAT COMPLETE AND TRUE SURFACE CONTACT IS ESTABLISHED BETWEEN THE PROPELLER HUB FLANGE AND THE ENGINE FLANGE.

- (5) Slide the propeller flange onto the engine flange.

CAUTION: NEW PROPELLER MOUNTING BOLTS MUST BE USED WHEN INITIALLY INSTALLING A NEW OR OVERHAULED PROPELLER.

- (6) Apply MIL-PRF-83483 anti-seize compound to the threaded surfaces of the mounting bolts. Refer to Table 3-2 for appropriate mounting hardware.

NOTE: If the propeller is removed between overhaul intervals, mounting bolts and washers may be reused if they are not damaged or corroded.

CAUTION: ID CHAMFER OF THE WASHER MUST BE FACING TOWARD THE BOLT HEAD. WASHERS WITHOUT CHAMFER MUST BE INSTALLED WITH ROLLED EDGES TOWARD THE BOLT HEAD (FIGURE 3-1).

- (7) Install the mounting bolts with washers through the engine flange and into the propeller hub flange. Refer to Figure 3-2.
- (8) Use a torque wrench and the specified torque wrench adaptor (see paragraph 1.A. Tooling) to torque all mounting bolts in sequences and steps shown in Figure 3-3. Refer to Table 3-3 and Figure 3-4 to determine the proper torque value.

- (9) Safety all mounting bolts with 0.032 inch (0.81 mm) minimum diameter stainless steel wire or equivalent aircraft safety cable and associated hardware (two bolts per safety.)

CAUTION: TO FACILITATE BOXING AND SHIPPING OF PROPELLERS, THE PISTON NUT (A-880-2) ON -5 STEEL HUB TURBINE PROPELLERS MAY HAVE BEEN REMOVED TO ALLOW ROTATING OF THE BLADES BEFORE PACKAGING.

- (10) Procedure for reinstallation of piston nut, if applicable.
- (a) Following the installation of the propeller, use a breaker bar and a one inch deep well socket to hold the pitch change rod.
 - (b) Using a 1-13/16 inch crowfoot wrench and torque wrench, torque the A-880-2 piston nut. Refer to Table 3-3 and Figure 3-4 for the proper torque value.

NOTE: The removal and subsequent reinstallation of the piston nut does not require that the propeller blade angles be re-checked.

- (11) Install the beta tube per airframe and/or engine manufacturer's instructions.
- (a) Follow the airframe manufacturer's instructions for adjusting the beta tube to obtain the correct low pitch (flight idle blade angle).
 - (b) Refer to the Aircraft Type Certificate Data Sheet for the low pitch blade angle setting.

- (12) If the propeller is equipped with an ice protection system that uses components supplied by Hartzell Propeller Inc., applicable instructions and technical information for the components supplied by Hartzell Propeller Inc. can be found in the following publications available on the Hartzell Propeller Inc. website at www.hartzellprop.com:
- (a) Manual 180 (30-61-80) - Propeller Ice Protection System Manual
 - (b) Manual 181 (30-60-81) - Propeller Ice Protection System Component Maintenance Manual

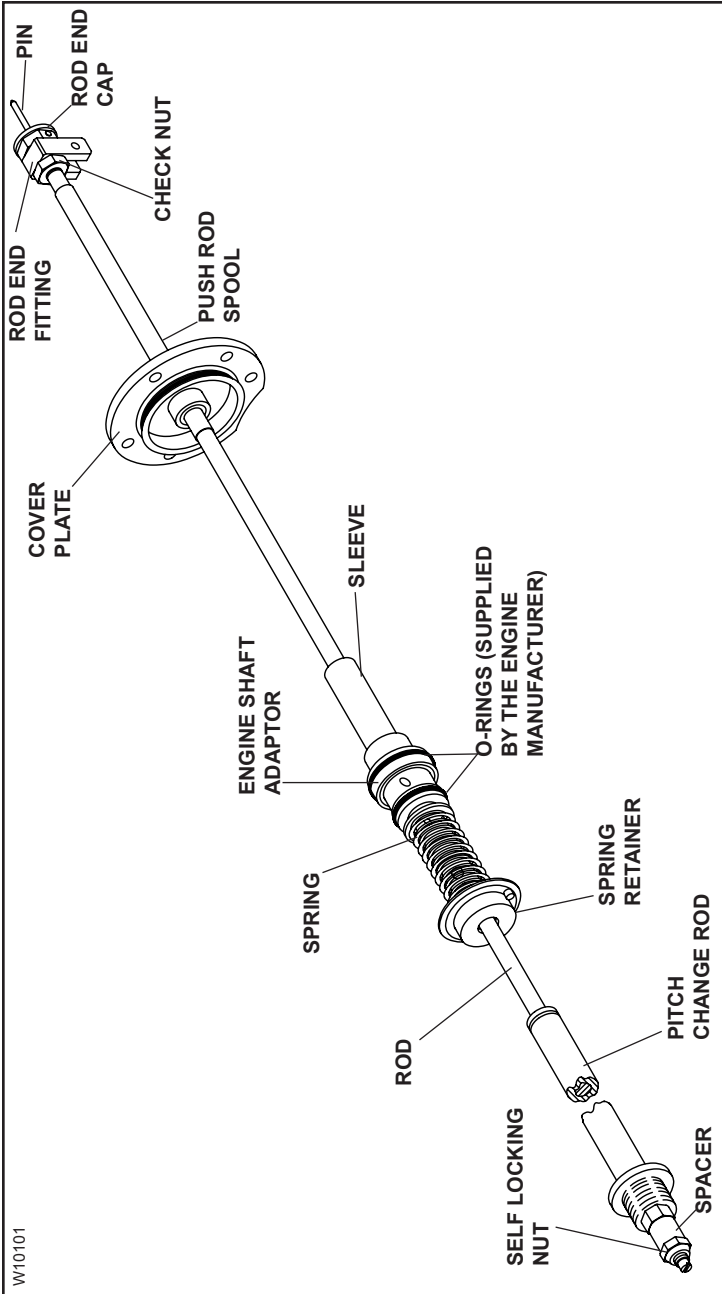

Beta Valve System
Figure 3-12

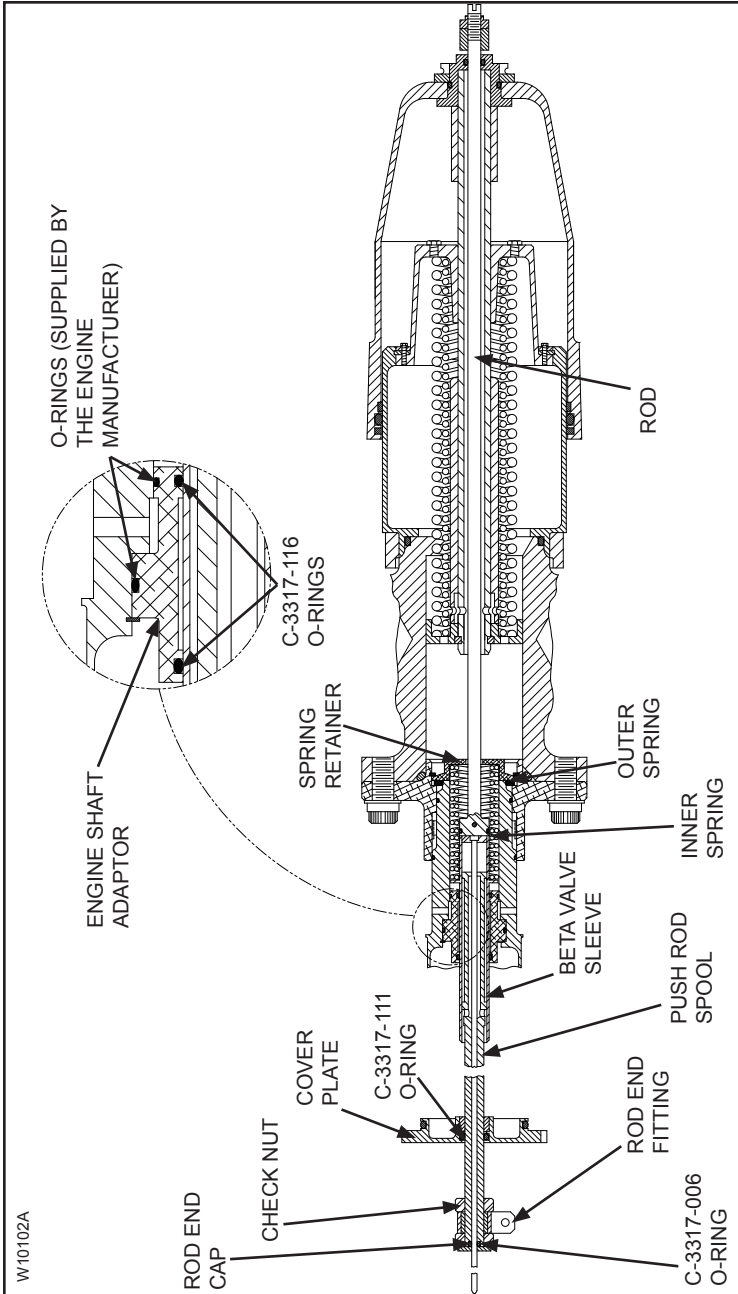

**Cross Section View of the Beta Valve System
Figure 3-13**

- (c) Manual 182 (61-12-82) - Propeller Electrical De-ice Boot Removal and Installation Manual
 - (d) Manual 183 (61-12-83) - Propeller Anti-icing Boot Removal and Installation Manual
- (13) Propeller ice protection system components not supplied by Hartzell Propeller Inc. are controlled by the applicable TC or STC holder's Instructions for Continued Airworthiness (ICA).
- G. Installing HC-()3()(-)7() Propeller on the Allison Engine

CAUTION: INSTRUCTIONS AND PROCEDURES IN THIS SECTION MAY INVOLVE CRITICAL PARTS. REFER TO THE INTRODUCTION CHAPTER OF THIS MANUAL FOR INFORMATION ABOUT PROPELLER CRITICAL PARTS. REFER TO THE ILLUSTRATED PARTS LIST CHAPTER OF THE APPLICABLE OVERHAUL MANUAL(S) FOR THE IDENTIFICATION OF SPECIFIC PROPELLER CRITICAL PARTS.

This propeller incorporates a beta valve assembly (Figures 3-12 and 3-13), which is installed inside of the propeller shaft and extends from the rear of the engine to the front of the propeller piston. This assembly is installed in the engine shaft before the propeller is installed.

- (1) Make sure that the shaft adaptor (see Figure 3-13) is installed in the engine shaft.
- (2) Install the C-3317-116 O-rings in the two grooves (see Figure 3-13) of the shaft adaptor.
- (3) Remove the cover plate from the rear of engine case. Refer to Figures 3-12 and 3-13.
- (4) Prepare the beta valve.

NOTE: The beta valve should be preassembled as shown in Figure 3-12 less the pitch change rod, engine shaft adaptor, engine supplied o-rings and cover plate when new or from overhaul.

Refer to Figures 3-12 and 3-13.

- (a) If the beta valve is supplied preassembled, remove the self locking nut, spacer, rod end cap, rod end fitting, bushing and check nut.
- (b) If the beta valve is supplied disassembled, assemble as follows:
 - 1 Slide the push rod spool onto the pin and into the sleeve with the threaded end facing away from the sleeve.
 - 2 Slide the inner and outer springs onto the rod up to and against the shoulder of the sleeve.
 - 3 Install the spring retainer onto the rod with the recessed center section facing toward the two springs.
- (5) Slide the partially assembled beta valve into the engine shaft from the front, allowing the push rod spool to extend out the rear of the engine.
 - (a) The shoulder of the sleeve should be against the shaft adaptor.
- (6) Compress the springs with spring retainer and install the retaining ring that is furnished with the engine to secure the spring retainer.

NOTE: A locator button on the spring retainer will fit into a recess in the engine shaft/flange.
- (7) Install the ID and OD O-rings on the engine cover, per the airframe or engine manufacturer's instructions.
- (8) Install the engine cover on the rear of the engine gear box encircling the beta valve push rod spool, per airframe or engine manufacturer's instructions.

NOTE: Cover plate fasteners are supplied by the engine manufacturer.

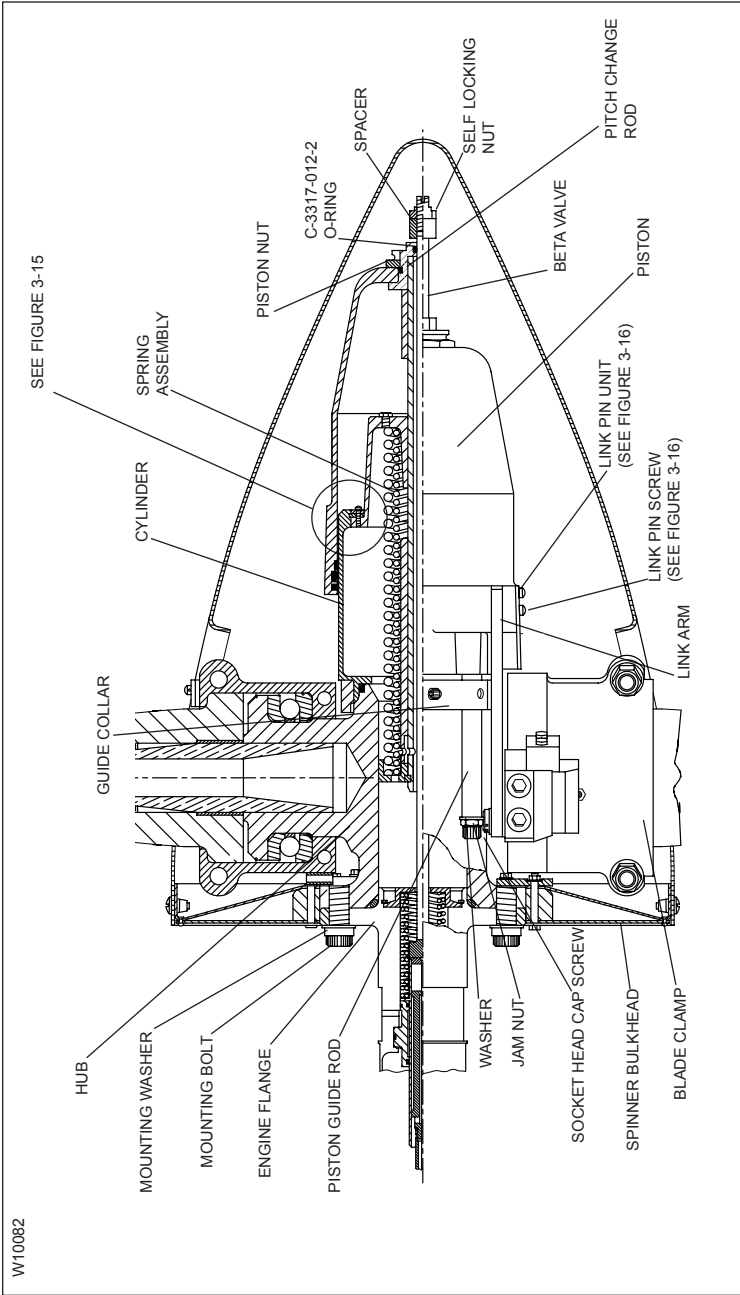

-7 () Propeller Assembly
Figure 3-14

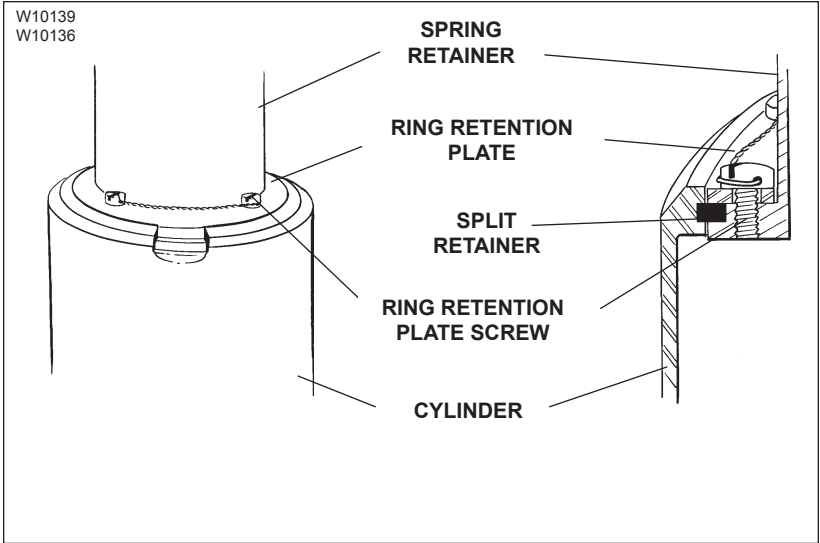

Spring Assembly to Cylinder Attachment Details
Figure 3-15

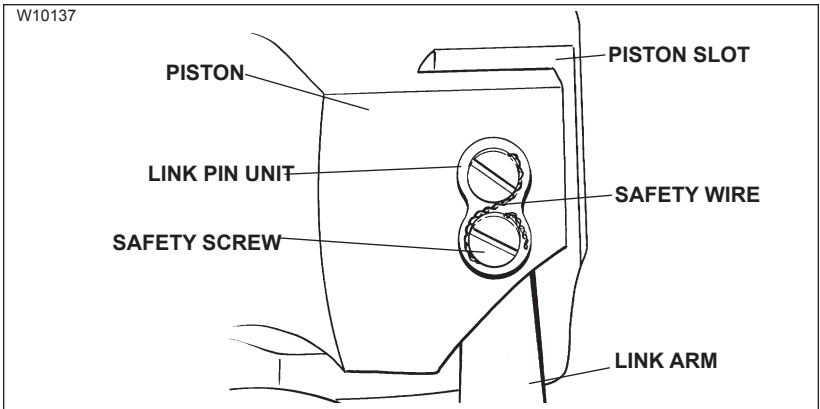

Piston to Link Arm Attachment Details
Figure 3-16

- (9) Prepare the propeller for installation (see Figures 3-14 through 3-16).
- (a) Piston removal
- 1 Remove the flexlock nut with a 1-7/16 inch wrench, if installed.
 - 2 Remove the safety wire from the three link pin units.
 - 3 Remove the safety screws from the link pin units.
 - 4 Remove the link pin units.
 - 5 Mark the piston and link pins with a felt tip pen or equivalent, so the piston can be reinstalled in the same position.
 - 6 Slide the link arms out of the piston slots.
 - 7 Remove the socket head cap screw, jam nut, and washer from each piston guide rod.
 - 8 Slide the piston off the cylinder.
- (b) Spring assembly removal.
- 1 Remove the ring retention plate screw safety wire.
 - 2 Remove the ring retention plate screws.
 - 3 Remove the retention plate.
 - 4 Remove the split retainer.
 - 5 Remove the spring assembly from the cylinder.

WARNING: MAKE SURE THE SLING IS RATED UP TO 800 LBS (363 KG) TO SUPPORT THE WEIGHT OF THE PROPELLER ASSEMBLY DURING REMOVAL.

CAUTION: INSERT THE DOWEL PINS INTO THE PROPELLER FLANGE USING A BRASS HAMMER OR EQUIVALENT TOOL TO PREVENT DAMAGE TO THE DOWEL PINS. THE DOWEL PINS ARE AN INTERFERENCE FIT WITH THE PROPELLER FLANGE.

(10) Insert two dowel pins (Table 3-1) through the threadless holes in the propeller flange, flush with the propeller side of the hub flange. The dowel pins will protrude from the engine side of the hub flange to engage the engine flange.

(11) With a suitable crane hoist and sling, carefully move the propeller assembly to the aircraft engine mounting flange.

NOTE: If the propeller is equipped with a de-ice system, refer to the General Maintenance Practices section in the Introduction chapter of this manual.

(12) Make sure the propeller hub flange and engine flange mating surfaces are clean.

(13) Install the specified O-ring on the engine flange. Refer to Table 3-1.

CAUTION: DO NOT ALLOW THE PROPELLER ASSEMBLY TO HIT OR REST ON THE BETA FEEDBACK ROD. THIS COULD BEND OR OTHERWISE DAMAGE THE FEEDBACK ROD.

(14) Slide the propeller over the beta valve assembly.

(15) Align the mounting holes and dowel pins in the propeller hub flange with the mounting holes and dowel pin holes in the engine flange.

CAUTION: MAKE SURE THAT COMPLETE AND TRUE SURFACE CONTACT IS ESTABLISHED BETWEEN THE PROPELLER HUB FLANGE AND THE ENGINE FLANGE.

(16) Slide the propeller hub flange onto the engine flange.

CAUTION 1: ID CHAMFER OF THE WASHER MUST BE FACING TOWARD THE BOLT HEAD. WASHERS WITHOUT CHAMFER MUST BE INSTALLED WITH ROLLED EDGES TOWARD THE BOLT HEAD (FIGURE 3-1).

CAUTION 2: NEW PROPELLER MOUNTING BOLTS MUST BE USED WHEN INITIALLY INSTALLING A NEW OR OVERHAULED PROPELLER.

(17) Install the propeller mounting bolts and washers through the engine flange and into the propeller hub flange. Refer to Table 3-2 for appropriate mounting hardware.

NOTE: If the propeller is removed between overhaul intervals, mounting bolts and washers may be reused if they are not damaged or corroded.

(18) Use a torque wrench and the specified torque wrench adaptor (see paragraph 1.A. Tooling in this chapter) to torque all mounting bolts in sequences and steps shown in Figure 3-3. Refer to Table 3-3 and Figure 3-4 to determine the proper torque value.

(19) Safety all mounting bolts with 0.032 inch (0.81 mm) minimum diameter stainless steel wire or equivalent aircraft safety cable and associated hardware (two bolts per safety.)

(20) Reinstall the spring assembly (see Figures 3-14 and 3-15).

(a) Slide the spring assembly into the cylinder and around the beta valve rod.

(b) Install split retainer between the cylinder and front spring retainer. Slide retainer into the recess in the cylinder.

- (c) Pull the spring retainer tight against the split retainer.
 - (d) Install the ring retention plate.
 - (e) Install the ring retention plate screws and tighten until snug.
 - (f) Safety screws with 0.032 inch (0.81 mm) minimum diameter stainless steel safety wire or equivalent aircraft safety cable and associated hardware (two bolts per safety.)
- (21) Install the C-3317-012-2 O-ring in the front inside cavity of the pitch change rod. (See Figure 3-14.)
- (22) Reinstall the piston on the cylinder and pitch change rod in the same position it was before disassembly. Refer to Figures 3-14 and 3-16.
- (a) Reconnect the link arms to the piston.
 - (b) Install the link pin units.
 - (c) Install the link pin unit safety screws.
 - (d) Safety the link pin screws with 0.032 inch (0.81 mm) minimum diameter stainless steel safety wire (see Figure 3-16).
 - (e) Hand tighten the A-880-1 piston nut on the pitch change rod.
 - (f) Position a breaker bar and a 5/8 inch deep well socket on the pitch change rod.
 - (g) Use 1-7/16 inch crowfoot wrench and torque wrench to torque the A-880-1 piston nut. Refer to Table 3-3 and Figure 3-4 for the proper torque value.

NOTE: The removal and subsequent reinstallation of the piston nut does not require that the propeller blade angles be re-checked.

- (h) Install a socket head screw, washer and jam nut onto each piston guide rod. Refer to Figure 3-14.
- (i) Torque the jam nuts on the piston guide rods as indicated in Table 3-3.

CAUTION: THE ROD END CAP MUST BOTTOM ON THE PUSH ROD SPOOL WHEN INSTALLED.

(23) Install the rod end cap onto the threaded end of the push rod spool.

NOTE: Do not tighten the set screw in the rod end cap.

(a) Mark the location of the set screw on the rod and then remove the end cap unit.

(b) File a flat, tangent to the rod, no deeper than the depth of the threads at the marked location of the set screw. Refer to Figure 3-17.

(24) Install the check nut onto the threaded end of the push rod spool.

(25) Install the bushing onto the threaded end of the push rod spool.

(26) Install the rod end fitting onto the threaded end of the push rod spool.

(27) Install the C-3317-006 O-ring in the cavity at the rear end of the push rod spool.

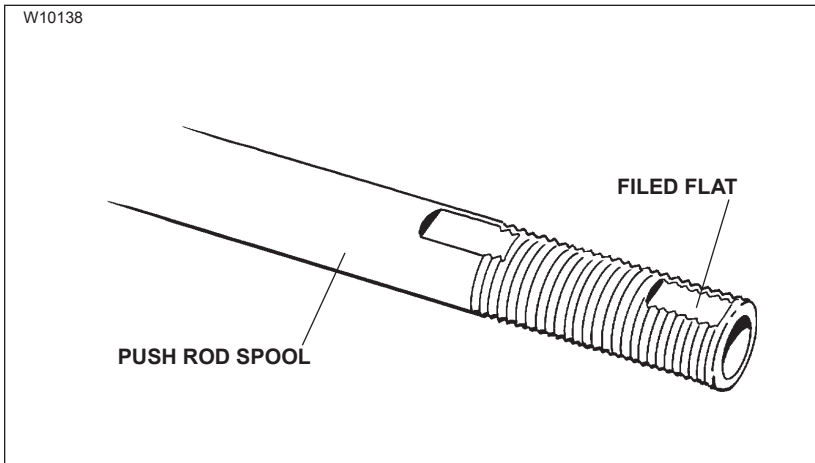

**Filed Rod for Set Screw
Figure 3-17**

(28) Install the rod end cap onto the threaded end of the push rod spool.

NOTE: Make sure the rod end cap is bottomed on the end of the push rod spool.

- (a) Apply Loctite® 272 to the set screw threads.
- (b) Tighten the set screw.

(29) Apply Loctite® 272 to the push rod threads where the check nut will be located on the push rod spool next to the bushing.

(30) Tighten the check nut against the bushing to torque indicated in Table 3-3.

(31) Attach engine mounted beta system control hardware to rod end fitting and adjust per airframe or engine manufacturer's instructions.

(32) Install the beta light switch against the pin per airframe manufacturer's instructions.

(33) Install the spacer and self-locking nut onto the front of the rod that protrudes through the front of the pitch change rod and piston.

- (a) Follow the airframe manufacturer's instructions for making pitch control adjustments.

(34) If the propeller is equipped with an ice protection system that uses components supplied by Hartzell Propeller Inc., applicable instructions and technical information for the components supplied by Hartzell Propeller Inc. can be found in the following publications available on the Hartzell Propeller Inc. website at www.hartzellprop.com:

- (a) Manual 180 (30-61-80) - Propeller Ice Protection System Manual
- (b) Manual 181 (30-60-81) - Propeller Ice Protection System Component Maintenance Manual
- (c) Manual 182 (61-12-82) - Propeller Electrical De-ice Boot Removal and Installation Manual
- (d) Manual 183 (61-12-83) - Propeller Anti-icing Boot Removal and Installation Manual

(35) Propeller ice protection system components not supplied by Hartzell Propeller Inc. are controlled by the applicable TC or STC holder's Instructions for Continued Airworthiness (ICA).

4. Spinner Dome Installation

CAUTION 1: INSTRUCTIONS AND PROCEDURES IN THIS SECTION MAY INVOLVE CRITICAL PARTS. REFER TO THE INTRODUCTION CHAPTER OF THIS MANUAL FOR INFORMATION ABOUT PROPELLER CRITICAL PARTS. REFER TO THE ILLUSTRATED PARTS LIST CHAPTER OF THE APPLICABLE OVERHAUL MANUAL(S) FOR THE IDENTIFICATION OF SPECIFIC PROPELLER CRITICAL PARTS.

CAUTION 2: TO PREVENT DAMAGE TO THE BLADE AND BLADE PAINT, WRAP THE BLADE SHANKS IN SEVERAL LAYERS OF MASKING OR DUCT TAPE BEFORE INSTALLING THE SPINNER DOME. REMOVE THE TAPE AFTER THE SPINNER IS INSTALLED.

CAUTION 3: SPINNER DOME WILL WOBBLE IF NOT ALIGNED PROPERLY, AND MAY AFFECT DYNAMIC BALANCE OF PROPELLER.

- A. Carefully slide the spinner dome over the reassembled propeller.
- B. Secure the spinner dome to the spinner bulkhead with the supplied screws and washers.

5. Post-Installation Checks

- A. Refer to the airframe manufacturer's instructions for post-installation checks.
- B. Perform a maximum RPM (Static) hydraulic low pitch stop check in accordance with the Testing and Troubleshooting chapter of this manual.

6. Spinner Dome Removal

CAUTION 1: INSTRUCTIONS AND PROCEDURES IN THIS SECTION MAY INVOLVE CRITICAL PARTS. REFER TO THE INTRODUCTION CHAPTER OF THIS MANUAL FOR INFORMATION ABOUT PROPELLER CRITICAL PARTS. REFER TO THE ILLUSTRATED PARTS LIST CHAPTER OF THE APPLICABLE OVERHAUL MANUAL(S) FOR THE IDENTIFICATION OF SPECIFIC PROPELLER CRITICAL PARTS.

CAUTION 2: TO PREVENT DAMAGING THE BLADE AND BLADE PAINT, WRAP THE BLADE SHANKS IN SEVERAL LAYERS OF MASKING OR DUCT TAPE BEFORE REMOVING THE SPINNER DOME.

- A. Remove the screws and washers that secure the spinner to the spinner bulkhead.
- B. Remove the spinner dome.

7. Propeller Assembly Removal**A. Removal of HC-B(3,5)()(-2() Propellers**

WARNING: FOR SAFETY REASONS, THE PROPELLER MUST BE PUT IN FEATHER POSITION BEFORE IT IS REMOVED FROM THE AIRCRAFT.

CAUTION: INSTRUCTIONS AND PROCEDURES IN THIS SECTION MAY INVOLVE CRITICAL PARTS. REFER TO THE INTRODUCTION CHAPTER OF THIS MANUAL FOR INFORMATION ABOUT PROPELLER CRITICAL PARTS. REFER TO THE ILLUSTRATED PARTS LIST CHAPTER OF THE APPLICABLE OVERHAUL MANUAL(S) FOR THE IDENTIFICATION OF SPECIFIC PROPELLER CRITICAL PARTS.

- (1) Remove the spinner dome in accordance with the procedure in the Spinner Dome Removal section of this chapter.
 - (a) If the propeller is equipped with an ice protection system that uses components supplied by Hartzell Propeller Inc., applicable instructions and technical information for the components supplied by Hartzell Propeller Inc. can be found in the following publications available on the Hartzell Propeller Inc. website at www.hartzellprop.com:
 - 1 Manual 180 (30-61-80) - Propeller Ice Protection System Manual
 - 2 Manual 181 (30-60-81) - Propeller Ice Protection System Component Maintenance Manual
 - 3 Manual 182 (61-12-82) - Propeller Electrical De-ice Boot Removal and Installation Manual
 - 4 Manual 183 (61-12-83) - Propeller Anti-icing Boot Removal and Installation Manual

- (b) Propeller ice protection system components not supplied by Hartzell Propeller Inc. are controlled by the applicable TC or STC holder's Instructions for Continued Airworthiness (ICA).

WARNING 1: DURING ENGINE INSTALLATION OR REMOVAL, USING THE PROPELLER TO SUPPORT THE WEIGHT OF THE ENGINE IS NOT AUTHORIZED. UNAPPROVED INSTALLATION AND REMOVAL TECHNIQUES MAY CAUSE DAMAGE TO THE PROPELLER THAT MAY LEAD TO FAILURE AND RESULT IN AN AIRCRAFT ACCIDENT.

WARNING 2: DURING PROPELLER REMOVAL, AIRFRAME MANUFACTURER'S MANUALS AND PROCEDURES MUST BE FOLLOWED BECAUSE THEY MAY CONTAIN ISSUES VITAL TO AIRCRAFT SAFETY THAT ARE NOT CONTAINED IN THIS MANUAL OR THE HARTZELL PROPELLER INC. OVERHAUL MANUALS 118F (61-10-18) AND 132A (61-10-32).

WARNING 3: MAKE SURE THE SLING IS RATED UP TO 800 LBS (363 KG) TO SUPPORT THE WEIGHT OF THE PROPELLER ASSEMBLY DURING REMOVAL.

- (2) Cut and remove the safety wire on the propeller mounting bolts.

- (3) Support the propeller assembly with a sling.

NOTE 1: Supporting the propeller with the sling may be delayed until all but two mounting bolts and washers have been removed to allow rotating the propeller for ease of bolt removal.

NOTE 2: If the propeller will be reinstalled, and it has been dynamically balanced, make an identifying mark on the propeller hub and a matching mark on the engine flange to ensure proper orientation during re-installation to prevent dynamic imbalance.

CAUTION: DISCARD THE PROPELLER MOUNTING BOLTS IF THEY ARE DAMAGED OR CORRODED, OR WHEN THE PROPELLER IS REMOVED FOR OVERHAUL.

- (4) Remove the propeller mounting bolts and washers.

NOTE: If the propeller is removed between overhaul intervals, mounting bolts and washers may be reused if they are not damaged or corroded.

CAUTION: USE ADEQUATE PRECAUTIONS TO PROTECT THE PROPELLER ASSEMBLY FROM DAMAGE WHEN IT IS REMOVED FROM THE AIRCRAFT ENGINE AND WHEN IT IS STORED.

- (5) Using the support sling, lift the propeller from the mounting flange.
- (6) Remove and discard the propeller mounting O-ring.
- (7) Place the propeller on a suitable cart for transportation.

B. Removal of HC-B(3,4,5)() (A,N,P)-3() Propellers

WARNING: FOR SAFETY REASONS, THE PROPELLER MUST BE PUT IN FEATHER POSITION BEFORE IT IS REMOVED FROM THE AIRCRAFT, IF THE BLADES ARE AT A STARTING BLADE ANGLE DUE TO START LOCKS.

CAUTION: INSTRUCTIONS AND PROCEDURES IN THIS SECTION MAY INVOLVE CRITICAL PARTS. REFER TO THE INTRODUCTION CHAPTER OF THIS MANUAL FOR INFORMATION ABOUT PROPELLER CRITICAL PARTS. REFER TO THE ILLUSTRATED PARTS LIST CHAPTER OF THE APPLICABLE OVERHAUL MANUAL(S) FOR THE IDENTIFICATION OF SPECIFIC PROPELLER CRITICAL PARTS.

- (1) Remove the spinner dome in accordance with the procedure in the Spinner Dome Removal section of this chapter.
 - (a) If the propeller is equipped with an ice protection system that uses components supplied by Hartzell Propeller Inc., applicable instructions and technical information for the components supplied by Hartzell Propeller Inc. can be found in the following publications available on the Hartzell Propeller Inc. website at www.hartzellprop.com:
 - 1 Manual 180 (30-61-80) - Propeller Ice Protection System Manual
 - 2 Manual 181 (30-60-81) - Propeller Ice Protection System Component Maintenance Manual
 - 3 Manual 182 (61-12-82) - Propeller Electrical De-ice Boot Removal and Installation Manual
 - 4 Manual 183 (61-12-83) - Propeller Anti-icing Boot Removal and Installation Manual

- (b) Propeller ice protection system components not supplied by Hartzell Propeller Inc. are controlled by the applicable TC or STC holder's Instructions for Continued Airworthiness (ICA).
 - (2) Disconnect the engine beta linkage and carbon block assembly from the beta ring per the airframe manufacturer's instructions. Refer to Figure 3-7.
 - (a) If the carbon block must be removed, perform the following procedures:
 - 1 Remove the snap ring that retains the carbon block assembly to the beta linkage.
 - 2 Remove the carbon block assembly.
- CAUTION: MAKE SURE THAT THE BETA LINKAGE IS DISCONNECTED BEFORE COMPRESSING THE BETA SYSTEM.**
- (3) Use the beta system puller, Hartzell Propeller Inc. P/N CST-2987, to compress the beta system and pull the beta ring forward to expose the propeller mounting bolts and washers. Refer to Figure 3-5.

WARNING 1: DURING ENGINE INSTALLATION OR REMOVAL, USING THE PROPELLER TO SUPPORT THE WEIGHT OF THE ENGINE IS NOT AUTHORIZED. UNAPPROVED INSTALLATION AND REMOVAL TECHNIQUES MAY CAUSE DAMAGE TO THE PROPELLER THAT MAY LEAD TO FAILURE AND RESULT IN AN AIRCRAFT ACCIDENT.

WARNING 2: DURING PROPELLER REMOVAL, AIRFRAME MANUFACTURER'S MANUALS AND PROCEDURES MUST BE FOLLOWED BECAUSE THEY MAY CONTAIN ISSUES VITAL TO AIRCRAFT SAFETY THAT ARE NOT CONTAINED IN THIS MANUAL OR THE HARTZELL PROPELLER INC. OVERHAUL MANUALS 118F (61-10-18) AND 132A (61-10-32).

WARNING 3: MAKE SURE THE SLING IS RATED UP TO 800 LBS (363 KG) TO SUPPORT THE WEIGHT OF THE PROPELLER ASSEMBLY DURING REMOVAL.

- (4) Cut and remove the safety wire on the propeller mounting bolts.
- (5) Support the propeller assembly with a sling.

NOTE 1: Supporting the propeller with the sling may be delayed until all but two mounting bolts and washers have been removed to allow rotating the propeller for ease of bolt removal.

NOTE 2: If the propeller will be reinstalled, and it has been dynamically balanced, make an identifying mark on the propeller hub and a matching mark on the engine flange to ensure proper orientation during re-installation to prevent dynamic imbalance.

CAUTION: DISCARD THE PROPELLER MOUNTING BOLTS IF THEY ARE DAMAGED OR CORRODED, OR WHEN THE PROPELLER IS REMOVED FOR OVERHAUL.

(6) Remove the propeller mounting bolts and washers.

NOTE: If the propeller is removed between overhaul intervals, mounting bolts and washers may be reused if they are not damaged or corroded.

CAUTION: USE ADEQUATE PRECAUTIONS TO PROTECT THE PROPELLER ASSEMBLY FROM DAMAGE WHEN IT IS REMOVED FROM THE AIRCRAFT ENGINE AND WHEN IT IS STORED.

(7) Using the support sling, lift the propeller from the mounting flange.

(8) Remove and discard the propeller mounting O-ring.

(9) Decompress and remove the beta system puller.

(10) Place the propeller on a suitable cart for transportation.

C. Removal of HC-B(3,4)()W-3() Propellers

CAUTION: INSTRUCTIONS AND PROCEDURES IN THIS SECTION MAY INVOLVE CRITICAL PARTS. REFER TO THE INTRODUCTION CHAPTER OF THIS MANUAL FOR INFORMATION ABOUT PROPELLER CRITICAL PARTS. REFER TO THE ILLUSTRATED PARTS LIST CHAPTER OF THE APPLICABLE OVERHAUL MANUAL(S) FOR THE IDENTIFICATION OF SPECIFIC PROPELLER CRITICAL PARTS.

- (1) Remove the spinner dome in accordance with the procedure in the Spinner Dome Removal section of this chapter.
 - (a) If the propeller is equipped with an ice protection system that uses components supplied by Hartzell Propeller Inc., applicable instructions and technical information for the components supplied by Hartzell Propeller Inc. can be found in the following publications available on the Hartzell Propeller Inc. website at www.hartzellprop.com:
 - 1 Manual 180 (30-61-80) - Propeller Ice Protection System Manual
 - 2 Manual 181 (30-60-81) - Propeller Ice Protection System Component Maintenance Manual
 - 3 Manual 182 (61-12-82) - Propeller Electrical De-ice Boot Removal and Installation Manual
 - 4 Manual 183 (61-12-83) - Propeller Anti-icing Boot Removal and Installation Manual
 - (b) Propeller ice protection system components not supplied by Hartzell Propeller Inc. are controlled by the applicable TC or STC holder's Instructions for Continued Airworthiness (ICA).
- (2) Disconnect the engine beta linkage and carbon block assembly from the beta ring per the airframe manufacturer's instructions. Refer to Figure 3-7.

(a) If the carbon block must be removed, perform the following procedures:

- 1 Remove the snap ring that retains the carbon block assembly to the beta linkage.
- 2 Remove the carbon block assembly.

CAUTION: MAKE SURE THAT THE BETA LINKAGE IS DISCONNECTED BEFORE COMPRESSING THE BETA SYSTEM.

(3) Use the beta system puller, Hartzell Propeller Inc. P/N CST-2987, to compress the beta system and pull the beta ring forward to expose the propeller mounting nuts and washers. Refer to Figure 3-5.

WARNING 1: DURING ENGINE INSTALLATION OR REMOVAL, USING THE PROPELLER TO SUPPORT THE WEIGHT OF THE ENGINE IS NOT AUTHORIZED. UNAPPROVED INSTALLATION AND REMOVAL TECHNIQUES MAY CAUSE DAMAGE TO THE PROPELLER THAT MAY LEAD TO FAILURE AND RESULT IN AN AIRCRAFT ACCIDENT.

WARNING 2: DURING PROPELLER REMOVAL, AIRFRAME MANUFACTURER'S MANUALS AND PROCEDURES MUST BE FOLLOWED BECAUSE THEY MAY CONTAIN ISSUES VITAL TO AIRCRAFT SAFETY THAT ARE NOT CONTAINED IN THIS MANUAL OR THE HARTZELL PROPELLER INC. OVERHAUL MANUALS 118F (61-10-18) AND 132A (61-10-32).

WARNING 3: MAKE SURE THE SLING IS RATED UP TO 800 LBS (363 KG) TO SUPPORT THE WEIGHT OF THE PROPELLER ASSEMBLY DURING REMOVAL.

(4) Cut and remove the safety wire on the propeller mounting studs.

- (5) Support the propeller assembly with a sling.

NOTE 1: Supporting the propeller with the sling may be delayed until all but two mounting nuts and washers have been removed to allow rotating the propeller for ease of nut removal.

NOTE 2: If the propeller will be reinstalled, and it has been dynamically balanced, make an identifying mark on the propeller hub and a matching mark on the engine flange to ensure proper orientation during re-installation to prevent dynamic imbalance.

CAUTION: DISCARD THE PROPELLER MOUNTING NUTS AND/OR WASHERS IF THEY ARE DAMAGED OR CORRODED, OR WHEN THE PROPELLER IS REMOVED FOR OVERHAUL.

- (6) Remove the propeller mounting nuts and washers.

NOTE: If the propeller is removed between overhaul intervals, mounting nuts and washers may be reused if they are not damaged or corroded.

CAUTION: USE ADEQUATE PRECAUTIONS TO PROTECT THE PROPELLER ASSEMBLY FROM DAMAGE WHEN IT IS REMOVED FROM THE AIRCRAFT ENGINE AND WHEN IT IS STORED.

- (7) Using the support sling, lift the propeller from the mounting flange.

- (8) Remove and discard the engine flange-to-spacer O-ring.

- (9) If the C-7364-2 spacer is not attached with flat-head screws, perform the following procedures:

(a) Remove the spacer from the hub.

(b) Remove and discard the hub-to-spacer O-ring.

- (10) If the C-7364-2 spacer is attached to the hub with flat-head screws, perform the following procedures if the O-ring must be replaced due to oil leakage.

(a) Remove the spacer attachment screws, if applicable.

- (b) Remove the C-7364-2 spacer.
- (c) Remove and discard the propeller hub-to-spacer O-ring.

(11) Decompress and remove the beta system puller.

(12) Place the propeller on a suitable cart for transportation.

D. Removal of HC-B(3,4,5)()(-)5() Propellers

WARNING: FOR SAFETY REASONS, THE PROPELLER MUST BE PUT IN FEATHER POSITION BEFORE IT IS REMOVED FROM THE AIRCRAFT.

CAUTION: INSTRUCTIONS AND PROCEDURES IN THIS SECTION MAY INVOLVE CRITICAL PARTS. REFER TO THE INTRODUCTION CHAPTER OF THIS MANUAL FOR INFORMATION ABOUT PROPELLER CRITICAL PARTS. REFER TO THE ILLUSTRATED PARTS LIST CHAPTER OF THE APPLICABLE OVERHAUL MANUAL(S) FOR THE IDENTIFICATION OF SPECIFIC PROPELLER CRITICAL PARTS.

(1) Remove the spinner dome in accordance with the procedure in the Spinner Dome Removal section of this chapter.

- (a) If the propeller is equipped with an ice protection system that uses components supplied by Hartzell Propeller Inc., applicable instructions and technical information for the components supplied by Hartzell Propeller Inc. can be found in the following publications available on the Hartzell Propeller Inc. website at www.hartzellprop.com:

- 1 Manual 180 (30-61-80) - Propeller Ice Protection System Manual
- 2 Manual 181 (30-60-81) - Propeller Ice Protection System Component Maintenance Manual
- 3 Manual 182 (61-12-82) - Propeller Electrical De-ice Boot Removal and Installation Manual

- 4 Manual 183 (61-12-83) - Propeller Anti-icing Boot Removal and Installation Manual
- (b) Propeller ice protection system components not supplied by Hartzell Propeller Inc. are controlled by the applicable TC or STC holder's Instructions for Continued Airworthiness (ICA).

CAUTION: THE BETA TUBE MUST BE REMOVED BEFORE THE PROPELLER ASSEMBLY IS REMOVED FROM THE AIRCRAFT. REFER TO THE AIRCRAFT MAINTENANCE INSTRUCTION MANUAL.

(2) Remove the beta tube.

WARNING 1: DURING ENGINE INSTALLATION OR REMOVAL, USING THE PROPELLER TO SUPPORT THE WEIGHT OF THE ENGINE IS NOT AUTHORIZED. UNAPPROVED INSTALLATION AND REMOVAL TECHNIQUES MAY CAUSE DAMAGE TO THE PROPELLER THAT MAY LEAD TO FAILURE AND RESULT IN AN AIRCRAFT ACCIDENT.

WARNING 2: DURING PROPELLER REMOVAL, AIRFRAME MANUFACTURER'S MANUALS AND PROCEDURES MUST BE FOLLOWED BECAUSE THEY MAY CONTAIN ISSUES VITAL TO AIRCRAFT SAFETY THAT ARE NOT CONTAINED IN THIS MANUAL OR THE HARTZELL PROPELLER INC. OVERHAUL MANUALS 118F (61-10-18) AND 132A (61-10-32).

WARNING 3: MAKE SURE THE SLING IS RATED UP TO 800 LBS (363 KG) TO SUPPORT THE WEIGHT OF THE PROPELLER ASSEMBLY DURING REMOVAL.

(3) Cut and remove the safety wire on the propeller mounting bolts.

- (4) Support the propeller assembly with a sling.

NOTE 1: Supporting the propeller with the sling may be delayed until all but two mounting bolts and washers have been removed to allow rotating the propeller for ease of bolt removal.

NOTE 2: If the propeller will be reinstalled, and it has been dynamically balanced, make an identifying mark on the propeller hub and a matching mark on the engine flange to ensure proper orientation during re-installation to prevent dynamic imbalance.

CAUTION: DISCARD THE PROPELLER MOUNTING BOLTS IF THEY ARE DAMAGED OR CORRODED, OR WHEN THE PROPELLER IS REMOVED FOR OVERHAUL.

- (5) Remove the propeller mounting bolts and washers.

NOTE: If the propeller is removed between overhaul intervals, mounting bolts and washers may be reused if they are not damaged or corroded.

CAUTION: USE ADEQUATE PRECAUTIONS TO PROTECT THE PROPELLER ASSEMBLY FROM DAMAGE WHEN IT IS REMOVED FROM THE AIRCRAFT ENGINE AND WHEN IT IS STORED.

- (6) Using the support sling, lift the propeller from the mounting flange.
- (7) If the propeller has a two-piece spinner mounting plate, proceed to paragraph 9.C.(9).
- (8) Propellers with the one-piece spinner mounting plate only (refer to Figure 3-11):
- (a) Remove the spinner mounting plate, spinner bulkhead and start locks, as a unit, from the propeller hub flange.
- (9) Remove and discard propeller mounting O-ring.
- (10) Place the propeller on a suitable cart for transportation.

E. Removal of HC-()3()-7() Propellers

CAUTION: INSTRUCTIONS AND PROCEDURES IN THIS SECTION MAY INVOLVE CRITICAL PARTS. REFER TO THE INTRODUCTION CHAPTER OF THIS MANUAL FOR INFORMATION ABOUT PROPELLER CRITICAL PARTS. REFER TO THE ILLUSTRATED PARTS LIST CHAPTER OF THE APPLICABLE OVERHAUL MANUAL(S) FOR THE IDENTIFICATION OF SPECIFIC PROPELLER CRITICAL PARTS.

NOTE: Refer to Figures 3-12 through 3-16 for the Beta Valve System.

- (1) Remove the spinner dome in accordance with the procedure in the Spinner Dome Removal section of this chapter.
 - (a) If the propeller is equipped with an ice protection system that uses components supplied by Hartzell Propeller Inc., applicable instructions and technical information for the components supplied by Hartzell Propeller Inc. can be found in the following publications available on the Hartzell Propeller Inc. website at www.hartzellprop.com:
 - 1 Manual 180 (30-61-80) - Propeller Ice Protection System Manual
 - 2 Manual 181 (30-60-81) - Propeller Ice Protection System Component Maintenance Manual
 - 3 Manual 182 (61-12-82) - Propeller Electrical De-ice Boot Removal and Installation Manual
 - 4 Manual 183 (61-12-83) - Propeller Anti-icing Boot Removal and Installation Manual
 - (b) Propeller ice protection system components not supplied by Hartzell Propeller Inc. are controlled by the applicable TC or STC holder's Instructions for Continued Airworthiness (ICA).

- (2) Remove the self-locking nut and spacer from the beta system rod that protrudes from the pitch change rod and piston.
- (3) Prepare the propeller for removal (see Figures 3-14 through 3-16).
 - (a) Piston Removal
 - 1 Remove the flexlock nut with Hartzell Propeller Inc. P/N AST-2917 or a 1 7/16 inch wrench, if installed.
 - 2 Remove the safety wire from the three link pin units.
 - 3 Remove the safety screws from the link pin units.
 - 4 Remove the link pin units.
 - 5 Mark the piston and link pins with a felt tip pen or equivalent, so the piston can be reinstalled in the same position.
 - 6 Slide the link arms out of the piston slots.
 - 7 Remove the socket head cap screw, jam nut, and washer from each piston guide rod.
 - 8 Slide the piston off the cylinder.
 - (b) Spring assembly removal.
 - 1 Remove the ring retention plate screw safety wire.
 - 2 Remove the ring retention plate screws.
 - 3 Remove the retention plate.
 - 4 Remove the split retainer.
 - 5 Remove the spring assembly from the cylinder.

- WARNING 1: DURING ENGINE INSTALLATION OR REMOVAL, USING THE PROPELLER TO SUPPORT THE WEIGHT OF THE ENGINE IS NOT AUTHORIZED. UNAPPROVED INSTALLATION AND REMOVAL TECHNIQUES MAY CAUSE DAMAGE TO THE PROPELLER THAT MAY LEAD TO FAILURE AND RESULT IN AN AIRCRAFT ACCIDENT.
- WARNING 2: DURING PROPELLER REMOVAL, AIRFRAME MANUFACTURER'S MANUALS AND PROCEDURES MUST BE FOLLOWED BECAUSE THEY MAY CONTAIN ISSUES VITAL TO AIRCRAFT SAFETY THAT ARE NOT CONTAINED IN THIS MANUAL OR THE HARTZELL PROPELLER INC. OVERHAUL MANUALS 118F (61-10-18) AND 132A (61-10-32).
- WARNING 3: MAKE SURE THE SLING IS RATED UP TO 800 LBS (363 KG) TO SUPPORT THE WEIGHT OF THE PROPELLER ASSEMBLY DURING REMOVAL.
- (4) Cut and remove the safety wire on the propeller mounting bolts.
- (5) Support the propeller assembly with a sling.
- NOTE 1: Supporting the propeller with the sling may be delayed until all but two mounting bolts and washers have been removed to allow rotating the propeller for ease of bolt removal.
- NOTE 2: If the propeller will be reinstalled, and it has been dynamically balanced, make an identifying mark on the propeller hub and a matching mark on the engine flange to ensure proper orientation during re-installation to prevent dynamic imbalance.

CAUTION: DISCARD THE PROPELLER MOUNTING BOLTS IF THEY ARE DAMAGED OR CORRODED, OR WHEN THE PROPELLER IS REMOVED FOR OVERHAUL.

(6) Remove the propeller mounting bolts and washers.

NOTE: If the propeller is removed between overhaul intervals, mounting bolts and washers may be reused if they are not damaged or corroded.

CAUTION 1: DO NOT ALLOW THE PROPELLER ASSEMBLY TO HIT OR REST ON THE BETA FEEDBACK ROD. THIS COULD BEND OR OTHERWISE DAMAGE THE ROD.

CAUTION 2: USE ADEQUATE PRECAUTIONS TO PROTECT THE PROPELLER ASSEMBLY FROM DAMAGE WHEN IT IS REMOVED FROM THE AIRCRAFT ENGINE AND WHEN IT IS STORED.

(7) Using the support sling, lift the propeller from the mounting flange.

(8) Remove and discard the propeller mounting O-ring.

(9) Place the propeller on a suitable cart for transportation.

F. Removal of Beta Valve Assembly for
HC-()3()(-)7() Propellers

(1) Remove the beta light switch from the beta valve pin per airframe manufacturer's instructions.

(2) Remove the engine mounted beta system control hardware from the beta valve rod end fitting, per the airframe/engine manufacturer's instructions.

(3) Loosen the check nut on the push rod spool from the bushing to break the Loctite® bond.

(4) Loosen the set screw to clear the threads of the push rod spool and to allow removal of the rod end cap.

(5) Loosen the rod end cap to break the Loctite® bond and remove the rod end cap from the push rod spool.

- (6) Remove the rod end fitting from the push rod spool.
- (7) Remove the bushing from the push rod spool.
- (8) Remove the check nut from the push rod spool.
- (9) Remove the O-ring from the cavity at the rear of the threaded end of the push rod spool.
- (10) Remove the engine cover from the rear of the engine gear box encircling the beta valve push rod spool per the airframe or engine manufacturer's instructions.
- (11) Remove and discard the ID and OD O-rings from the engine cover.

WARNING: TO AVOID INJURY, SPRINGS IN THE ENGINE SHAFT ARE PRELOADED AND MUST BE PROPERLY CONTROLLED WHEN RELEASING THE SPRING RETAINER.

- (12) Secure the spring retainer and remove the retaining ring that holds the spring retainer in place.
- (13) Remove the spring retainer from the engine shaft and beta valve.
- (14) Remove the inner and outer springs from the engine shaft and beta valve.
- (15) Slide the beta valve's remaining assembly and push rod spool out of the engine shaft toward where the propeller had been mounted.
- (16) Place all beta valve parts together, including the self locking nut and spacer that were removed to allow the removal of the propeller assembly.

(This page is intentionally blank.)

CONTENTS

1. Operational Tests	4-3
A. Initial Run-Up	4-3
B. Post-Run Check.....	4-3
C. Maximum RPM (Static) Hydraulic Low Pitch Stop Check.....	4-3
D. Feathering Pitch Stop Adjustment	4-4
E. Start Lock Unit Adjustment	4-4
F. Propeller Ice Protection System	4-4
2. Troubleshooting	4-4
A. Hunting and Surging	4-4
B. Engine Speed Varies with Airspeed	4-5
C. Loss of Propeller Control	4-6
D. Failure to Feather (or feathers slowly)	4-6
E. Failure to Unfeather	4-7
F. Start Lock Units Fail to Latch on Shutdown (-2, -5 and some -3 Models)	4-7
G. Vibration.....	4-8
H. Propeller Overspeed.....	4-9
I. Propeller Underspeed.....	4-9
J. Oil or Grease Leakage.....	4-10

(This page is intentionally blank.)

1. Operational Tests

Following propeller installation, and before flight, the propeller hydraulic system must be purged of air and proper operation verified.

A. Initial Run-Up

- (1) Perform engine start and warm-up per the Pilot's Operating Handbook (POH).
- (2) Cycle the condition lever throughout its operating blade angle range from reverse or low to high (or as directed by the POH).

NOTE: Air trapped in the propeller hydraulic system will cause the pitch control to be imprecise and may result in propeller surging.

- (3) Repeat this procedure at least three times to purge air from the propeller hydraulic system and to introduce warmed oil to the cylinder.

NOTE: Pitch change response on the first operation from low to high blade angle may be slow, but should speed up on the second and third cycles.

- (4) Verify proper operation from reverse or low pitch, to high pitch and throughout operating range.
- (5) Shut down the engine in accordance with the POH.

WARNING: REFER TO THE AIRCRAFT MAINTENANCE MANUAL FOR ADDITIONAL PROCEDURES THAT MAY BE REQUIRED AFTER PROPELLER INSTALLATION.

B. Post-Run Check

After engine shutdown, check the propeller for signs of engine oil leakage.

C. Maximum RPM (Static) Hydraulic Low Pitch Stop Check

The Maximum RPM (hydraulic low pitch stop) is normally set at the factory per the aircraft manufacturer's requirements, and should not require any additional adjustment. Adjustments may be required after maintenance or because of specific aircraft variances.

Adjustments must be done in accordance with the airframe manufacturer's specification, found in the airframe manufacturer's manual.

D. Feathering Pitch Stop Adjustment

The feathering pitch stop is set at the factory in accordance with the aircraft manufacturer's recommendations. This stop is adjustable only by an appropriately licensed propeller repair station, aircraft manufacturer, or the Hartzell Propeller Inc. factory.

E. Start Lock Unit Adjustment

Start lock units are set at the factory in accordance with the aircraft manufacturer's recommendations. These are adjustable only by an appropriately licensed propeller repair station or at the Hartzell Propeller Inc. factory.

F. Propeller Ice Protection System**(1) Electric De-ice System**

(a) Consult the Pilot Operating Handbook (including all supplements) regarding flight into conditions of known icing. The aircraft may not be certificated for flight in known icing conditions, even though propeller de-ice equipment is installed.

(b) Refer to the De-ice Systems chapter of this manual for functional tests of the de-ice system.

(2) Anti-ice System

(a) Consult the Pilot Operating Handbook (including all supplements) regarding flight into conditions of known icing. The aircraft may not be certificated for flight in known icing conditions, even though propeller anti-ice equipment is installed.

(b) Refer to the Anti-ice and De-ice Systems chapter of this manual for functional tests of the anti-ice system.

2. Troubleshooting**A. Hunting and Surging**

Hunting is characterized by a cyclic variation in engine speed above and below desired speed. Surging is characterized by a large increase/decrease in engine speed, followed by a return to set speed after one or two occurrences.

(1) If propeller is hunting, an appropriately licensed propeller repair station should check:

(a) Governor

(b) Fuel control

(c) Synchrophaser or synchronizer

- (2) If propeller is surging:
 - (a) Perform the steps 1.A.(1) through 1.A.(5) in the Operational Tests section of this chapter to release trapped air from the propeller. If surging reoccurs, it is most likely due to a faulty governor.
 - (b) Hunting and/or surging may also be caused by friction or binding within the governor control, or by internal propeller corrosion, which causes the propeller to react slower to governor commands.

NOTE: The propeller must be tested on a test bench at an appropriately licensed propeller repair facility to isolate these faults.

B. Engine Speed Varies with Airspeed

- (1) Constant speed propeller models will experience small variances in engine speed that are normal and are no cause for concern.
- (2) Increase in engine speed while descending or increasing airspeed:
 - (a) Governor is not reducing oil volume.
 - (b) Friction in propeller.
- (3) Decrease in engine speed while increasing airspeed:
 - (a) Governor pilot valve is stuck and is excessively decreasing oil volume.
 - (b) Feathering command engaged on propeller pitch control.
- (4) Increase in engine speed while decreasing airspeed:
 - (a) Governor pilot valve is stuck and is excessively increasing oil volume.
- (5) Decrease in engine speed while decreasing airspeed:
 - (a) Governor is not increasing oil volume in propeller.
 - (b) Friction in propeller.

- C. Loss of Propeller Control
- (1) Propeller goes to uncommanded high pitch (or feather)
 - (a) Loss of propeller oil pressure - check:
 - 1 Governor pressure relief valve.
 - 2 Governor drive.
 - 3 Engine oil supply.
 - (b) Start lock not engaging.
 - (2) Propeller goes to uncommanded low pitch (high RPM)
 - (a) Governor pilot valve sticking.
 - (3) RPM increases with power and airspeed, propeller RPM control has little or no effect.
 - (a) Excessive friction in blade bearings or pitch change mechanism.
 - (b) Broken feathering spring.
 - (4) RPM control sluggish (especially on reducing RPM).
 - (a) Broken feathering spring.
- D. Failure to Feather (or feathers slowly)
- (1) Broken feathering spring.
 - (2) Check for proper function and rigging of propeller/governor control linkage.
 - (3) Check governor drain function.
 - (4) Propeller must be checked for misadjustment or internal corrosion (usually in blade bearings or pitch changing mechanism) that results in excessive friction. This must be accomplished at an appropriately licensed propeller repair facility.

E. Failure to Unfeather

- (1) Check for proper function and rigging of propeller control linkage.
- (2) Check governor function.
- (3) Propeller must be checked for misadjustment or internal corrosion (usually in blade bearings or pitch change mechanism) that results in excessive friction. This must be accomplished at an appropriately licensed propeller repair facility.

F. Start Lock Units Fail to Latch on Shutdown

(-2, -5 and some -3 Models)

- (1) Propeller was feathered before shutdown.
- (2) Shutdown occurred at high RPM with propeller control off the low pitch stop.
 - (a) The problem may be solved by restarting the engine, placing the propeller control in the proper shut down position, and then shutting down the engine.
 - (b) For HC-B(3,4,5)()(-5(), the problem may be solved by using the engine auxiliary pump to reposition the propeller on the start lock units.
- (3) Excessive governor pump leakage.

The problem should be referred to an appropriately licensed propeller repair facility.
- (4) Broken start lock unit(s).

The problem should be referred to an appropriately licensed propeller repair facility.

G. Vibration

CAUTION: ANY VIBRATION THAT CAN BE DESCRIBED AS APPEARING SUDDENLY, OR IS ACCOMPANIED BY UNEXPLAINED GREASE LEAKAGE, SHOULD BE INVESTIGATED IMMEDIATELY BEFORE FURTHER FLIGHT.

NOTE: Vibration problems due to propeller system imbalance are normally felt throughout the RPM range, with the intensity of vibration increasing with RPM. Vibration problems that occur in a narrow RPM range are a symptom of resonance, that is potentially harmful to the propeller. Avoid operation in that RPM range until the propeller can be checked by an appropriately licensed propeller repair facility.

(1) Check:

- (a) Control surfaces, exhaust system, landing gear doors, etc. for excessive play, which may be causing vibration unrelated to the propeller.
- (b) Secure attachment of engine mounted hardware.
- (c) Engine mount wear.
- (d) Uneven lubrication of propeller.
- (e) Proper engine/propeller flange mating.
- (f) Blade track. (For procedure, refer to the Inspection and Check chapter of this manual.)
- (g) Blade angles:
Blade angle must be within 0.2 degree from blade to blade at the reference station. (For HC-B5M(A, P)-3(A, C, D, F) propellers installed on Air Tractor aircraft, low pitch angles must be within a blade-to-blade tolerance of 0.2 degrees at the 36, 42, 48, and 54 inch stations.)

- (h) Spinner for cracks, improper installation, or wobble during operation.
- (i) Static balance.
- (j) Airfoil profile identical between blades (after overhaul or rework for nicks - verify at an appropriately licensed propeller repair facility.
- (k) Hub, blade or blade clamp for damage or cracking.
- (l) Grease or oil leakage from a seemingly solid surface of the hub, blade clamp or blade.
- (m) Blade deformation.

NOTE: Dynamic balancing is recommended after installing or performing maintenance on a propeller. While normally an optional task, it may be required by the engine or airframe manufacturer to make certain the propeller/engine combination is balanced within close tolerances before operation. Refer to the engine or airframe manuals, and the Maintenance Practices chapter of this manual.

H. Propeller Overspeed

(1) Check:

- (a) Low pitch stop adjustment.
- (b) Governor maximum RPM set too high.
- (c) Broken feathering spring.
- (d) Governor pilot valve jammed, supplying high pressure only.
- (e) Tachometer error.

I. Propeller Underspeed

(1) Check:

- (a) Governor oil pressure low.
- (b) Governor oil passage clogged.
- (c) Tachometer error.

J. Oil or Grease Leakage

CAUTION: GREASE LEAKAGE THAT CAN BE DESCRIBED AS EXCESSIVE AND APPEARING SUDDENLY, ESPECIALLY WHEN ACCOMPANIED BY VIBRATION, SHOULD BE INVESTIGATED IMMEDIATELY BEFORE FURTHER FLIGHT.

(1) Grease Leakage - Probable Cause:

- (a) Overlubrication
- (b) Improperly torqued or loose lubrication fitting.
Tighten the fitting and torque in accordance with the Torque Values Table found in the Installation and Removal chapter of this manual.
- (c) Defective lubrication fitting. (Replace the fitting.)
- (d) Incorrect or damaged O-ring between the blade clamp and the propeller hub. (Refer to an appropriately licensed propeller repair facility. for replacement of the O-ring).
- (e) Grease leaks past the blade clamp seal gaskets. (Refer to an appropriately licensed propeller repair facility for replacement of the gasket.)
- (f) Grease leaks from between the blade clamp and the blade. (Refer to an appropriately licensed propeller repair facility for replacement of sealant.)
- (g) Improper application of silicone sealant on the clamp radius of the bearing-to-clamp interface. (Refer to an appropriately licensed propeller repair facility for reapplication of silicone sealant.)
- (h) Grease leaks from the clamp when the blade is pointed up and in a static position.
 - 1 Oil separating from the grease. Approved propeller lubricants are listed in the Maintenance Practices chapter of this manual. These lubricants have varying separation rates. If a clamp seal leaks after the first ten hours of operation, consult an appropriately licensed propeller repair facility.

- (2) Oil Leakage - Probable Cause
- (a) Faulty or missing O-ring seal between the hub and the cylinder.
 - (b) Faulty or missing O-ring seal between the piston and the cylinder at the front of the piston.
 - (c) Displaced felt seal between the piston and the cylinder
 - (d) Faulty or missing O-ring between the propeller hub and the engine flange.

NOTE: The HC-B(3,4)()W-3() propeller models have an additional O-ring between the spacer and hub flange.

- (e) Faulty or missing O-ring between the piston and the pitch change rod.

(This page is intentionally blank.)

INSPECTION AND CHECK - CONTENTS

1. Pre-Flight Checks.....	5-3
2. Post-Flight Checks.....	5-5
3. Operational Checks.....	5-6
4. Required Periodic Inspections and Maintenance.....	5-7
A. Periodic Inspections.....	5-7
B. Periodic Maintenance.....	5-8
C. Compliance Inspections.....	5-8
D. Airworthiness Limitations.....	5-11
E. Overhaul Periods.....	5-12
5. Inspection Procedures.....	5-13
A. Blade Damage.....	5-13
B. Grease or Oil Leakage.....	5-13
C. Vibration.....	5-15
D. Tachometer Inspection.....	5-16
E. Blade Track.....	5-19
F. Loose Blades.....	5-20
G. Corrosion.....	5-20
H. Spinner Damage.....	5-20
I. Electric De-ice System.....	5-20
J. Anti-ice System.....	5-21
6. Special Inspections.....	5-21
A. Overspeed/Overtorque.....	5-21
B. Propeller Ground Idle Operating Restrictions.....	5-24
C. Lightning Strike.....	5-30
D. Foreign Object Strike.....	5-31
E. Fire Damage or Heat Damage.....	5-33
7. Long Term Storage.....	5-34

INSPECTION AND CHECK - FIGURES

Checking Blade Track..... Figure 5-15-18

Blade Play Figure 5-25-18

Turbine Engine Overspeed Limits Figure 5-35-22

Turbine Engine Overtorque Limits Figure 5-45-23

Example of an Evaluation of Ground
 Idle RPM Check Figure 5-55-25

Corrective Action Required..... Figure 5-65-26

1. Pre-Flight Checks

CAUTION: INSTRUCTIONS AND PROCEDURES IN THIS SECTION MAY INVOLVE CRITICAL PARTS. REFER TO THE INTRODUCTION CHAPTER OF THIS MANUAL FOR INFORMATION ABOUT PROPELLER CRITICAL PARTS. REFER TO THE ILLUSTRATED PARTS LIST CHAPTER OF THE APPLICABLE OVERHAUL MANUAL(S) FOR THE IDENTIFICATION OF SPECIFIC PROPELLER CRITICAL PARTS.

Follow propeller preflight inspection procedures as specified in the Pilot Operating Handbook (POH) or this manual. In addition, perform the following inspections:

A. Blades

- (1) Visually inspect the entire blade (lead, trail, face, and camber sides) for nicks, gouges, and cracks. Refer to the Maintenance Practices chapter of this manual for blade repair information. Normal blade lead edge erosion (sand-blasted appearance) is acceptable, and does not require removal before further flight.
- (2) Visually inspect the blades for lightning strike. Refer to the Lightning Strike Damage information in the Special Inspections section of this chapter for a description of damage.

B. Inspect the spinner and visible blade retention components for damage or cracks. Repair or replace components as required before further flight.

C. Check for loose/missing hardware. Retighten or reinstall as necessary.

WARNING: ABNORMAL GREASE LEAKAGE CAN BE AN INDICATION OF A FAILING PROPELLER BLADE OR BLADE RETENTION COMPONENT. AN IN-FLIGHT BLADE SEPARATION CAN RESULT IN A CATASTROPHIC AIRCRAFT ACCIDENT.

D. Inspect for grease and oil leakage and determine its source.

- E. Check the blades for radial play or movement of the blade tip (in and out or back and forth). Refer to Loose Blades in the Periodic Inspections section of this chapter for blade play limits.
- F. Inspect de-ice boots (if installed) for damage. Refer to the De-ice Systems chapter of this manual for inspection information.

WARNING: ABNORMAL VIBRATION CAN BE AN INDICATION OF A FAILING PROPELLER BLADE OR BLADE RETENTION COMPONENT. AN IN-FLIGHT BLADE SEPARATION CAN RESULT IN A CATASTROPHIC AIRCRAFT ACCIDENT.

- G. Refer to Periodic Inspections within this section for additional inspection information and possible corrections to any discrepancies discovered as a result of pre-flight checks.

2. Post-Flight Checks

CAUTION: INSTRUCTIONS AND PROCEDURES IN THIS SECTION MAY INVOLVE CRITICAL PARTS. REFER TO THE INTRODUCTION CHAPTER OF THIS MANUAL FOR INFORMATION ABOUT PROPELLER CRITICAL PARTS. REFER TO THE ILLUSTRATED PARTS LIST CHAPTER OF THE APPLICABLE OVERHAUL MANUAL(S) FOR THE IDENTIFICATION OF SPECIFIC PROPELLER CRITICAL PARTS.

A. HC-B3TN-3DL/LT10282()-9.5R propellers installed on Piaggio P-166 DL3 aircraft

(1) As a result of the “pusher” configuration, propeller blades on affected aircraft are exposed to hot exhaust gasses, which makes them more susceptible to erosion and corrosion. Additional inspections and corrosion preventative measures are required.

(a) Perform blade cleaning within three days after any flight.

NOTE: It is recommended to perform blade cleaning after the last flight of each day.

(b) Blade Cleaning

1 Use a cloth dampened with an approved solvent/cleaner to thoroughly clean each blade shank where exposed to engine exhaust and remove all foreign matter/exhaust residue.

2 Visually inspect for corrosion indications and paint condition.

3 Paint must be in good condition in the area exposed to exhaust gasses. Repair and repaint in accordance with the Maintenance Practices Chapter of this manual or by an appropriately licensed propeller repair facility if:

a Any of the underlying aluminum blade is exposed.

b There are any indications of corrosion, such as pitting or any other unusual conditions.

3. Operational Checks

CAUTION: INSTRUCTIONS AND PROCEDURES IN THIS SECTION MAY INVOLVE CRITICAL PARTS. REFER TO THE INTRODUCTION CHAPTER OF THIS MANUAL FOR INFORMATION ABOUT PROPELLER CRITICAL PARTS. REFER TO THE ILLUSTRATED PARTS LIST CHAPTER OF THE APPLICABLE OVERHAUL MANUAL(S) FOR THE IDENTIFICATION OF SPECIFIC PROPELLER CRITICAL PARTS.

- A. Following propeller installation or as required, perform initial run-up as outlined in Operational Tests in the Testing and Troubleshooting chapter of this manual.
- B. Check the propeller speed control and operation from reverse or low pitch to high pitch, using the procedure specified in the Pilot Operating Handbook (POH) for the aircraft.

WARNING: ABNORMAL VIBRATION CAN BE AN INDICATION OF A FAILING PROPELLER BLADE OR BLADE RETENTION COMPONENT. AN IN-FLIGHT BLADE SEPARATION CAN RESULT IN A CATASTROPHIC AIRCRAFT ACCIDENT.

- C. Check for any abnormal vibration during this run-up. If vibration occurs, shut the engine down, determine the cause, and correct it before further flight. Refer to the Vibration section in the Testing and Troubleshooting chapter of this manual.
- D. Refer to Periodic Inspections in this chapter for additional inspection information and possible corrections to any discrepancies discovered as a result of Pre-Flight Checks.
- E. Refer to the airframe manufacturer's manual for additional operational checks.

4. Required Periodic Inspections and Maintenance

CAUTION: INSTRUCTIONS AND PROCEDURES IN THIS SECTION MAY INVOLVE CRITICAL PARTS. REFER TO THE INTRODUCTION CHAPTER OF THIS MANUAL FOR INFORMATION ABOUT PROPELLER CRITICAL PARTS. REFER TO THE ILLUSTRATED PARTS LIST CHAPTER OF THE APPLICABLE OVERHAUL MANUAL(S) FOR THE IDENTIFICATION OF SPECIFIC PROPELLER CRITICAL PARTS.

A. Periodic Inspections

- (1) Complete detailed inspection procedures at 400 hour intervals, not to exceed twelve (12) calendar months.
 - (a) Inspection and maintenance specified by an airframe manufacturer's maintenance program and approved by the applicable airworthiness agency may not coincide with the inspection time interval specified. In this situation the airframe manufacturer's schedule may be applied with the exception that the calendar limit for the inspection interval may not exceed (12) calendar months.
 - (b) Refer to Inspection Procedures in this chapter for additional inspection information and possible corrections to any discrepancies discovered as a result of the Periodic Inspection.
- (2) Remove the spinner dome.
- (3) Visually inspect the entire blade for nicks and cracks. If any damage is discovered, refer to the Blade Repairs section in the Maintenance Practices chapter of this manual for additional information.
 - (a) A cracked blade must be referred to an appropriately licensed propeller repair facility.
- (4) Inspect all visible propeller parts for cracks, wear, or unsafe conditions.

- (5) Check for oil and grease leaks. Refer to Oil and Grease Leakage in the Inspection Procedures section of this chapter.
- (6) If a blade track problem is suspected, check the blade track. Refer to Blade Track in the Inspection Procedures section of this chapter.
- (7) Make an entry in the log book verifying this inspection.

B. Periodic Maintenance

Lubricate the propeller assembly. Refer to Lubrication in the Maintenance Practices chapter of this manual for intervals and procedures.

C. Compliance Inspections

(1) B-834-20 and B-834-22 Guide Collars

- (a) This inspection applies to B-834-20 and B-834-22 guide collars installed on HC-B3TN-5(M,N,P)(L) propellers with serial numbers below BV-4870 (right hand rotation), and BV-4862 (left hand rotation).

NOTE: An "L" following the propeller model number denotes left hand rotation, i.e., HC-B3TN-5(M,N,P)L.

- (b) These guide collars require inspection for cracks between the surface of the guide collar and the thin wall of the counterbored hole where the guide collar screw is inserted. This repetitive inspection must be performed at 500 hour intervals.
- (c) Record compliance with this inspection in the propeller logbook.
- (d) If a crack is found, an appropriately licensed propeller repair facility must replace both the guide collar and the start lock units with current parts configurations identified in Hartzell Propeller Inc. Manual 118F (61-10-18). Replacing the guide collar and start lock units with the current parts configurations terminates this inspection.

- (2) Blade Inspection for HC-B3TN-3DL/LT10282()-9.5R
Propellers Installed on Piaggio P166 DL3 Aircraft

CAUTION: ESTABLISH MORE FREQUENT
INTERVALS FOR INSPECTION IF
SERVICE EXPERIENCE INDICATES
THAT SEVERE CORROSION IS
FOUND DURING INSPECTIONS.

- (a) Visually inspect each blade for paint erosion and
corrosion at intervals not exceeding 150 hours
of operation, 12 calendar months, or at annual
inspection, whichever occurs first.
- 1** For scheduling purposes, the inspection interval
has a maximum 10 percent additional
non-cumulative flight hour tolerance.
 - a** For example, the initial 150 hour inspection
is overflowed to 160 hours, and then
inspected at this time. The next inspection
must be accomplished 140 flight hours from
previous inspection.

WARNING: CLEANING AGENTS (ACETONE, #700
LACQUER THINNER, AND MEK), ARE
FLAMMABLE AND TOXIC TO THE SKIN,
EYES, AND RESPIRATORY TRACT. SKIN
AND EYE PROTECTION ARE REQUIRED.
AVOID PROLONGED CONTACT. USE IN
WELL VENTILATED AREA.

- 2** Use a cloth dampened with an approved solvent/
cleaner to thoroughly clean each blade shank
where exposed to engine exhaust and remove
all foreign matter/exhaust residue.
- 3** Paint must be in good condition in the area
exposed to exhaust gasses. Repair and
repainting is required if:
 - a** Any of the underlying aluminum blade is
exposed.
 - b** There are any indications of corrosion, such
as pitting or any other unusual conditions.

- 4 All corrosion indications require repair and subsequent repainting by an appropriately licensed propeller repair facility.
- a Refer to FAA Advisory Circular AC 43.4A (or subsequent revision) for additional information concerning corrosion. This circular provides definitions, repair procedures, safety precautions, etc.
 - (b) If repair and repainting are required, refer to the Blade Repairs section in the Maintenance Practices chapter of this manual for additional information.
NOTE: Qualified personnel must make the determination if repairs can be made locally or must be sent to an appropriately licensed propeller repair facility. Hartzell Propeller Inc. recommends that in “borderline” or questionable situations it is preferable to send the propeller to an appropriately licensed propeller repair facility.
 - (c) Record compliance with this inspection in the propeller logbook.

D. Airworthiness Limitations

- (1) Certain components, as well as the entire propeller may have specific life limits established as part of the certification by the FAA. Such limits call for mandatory replacement of specified parts after a defined number of hours and/or cycles of use.
- (2) Life limited component times may exist for the propeller models covered in this manual. Life limited components will be identified in the Airworthiness Limitations chapter of this manual.
- (3) Refer to the latest revision of Hartzell Propeller Inc. Service Letter HC-SL-61-61Y for life limited data that has not yet been incorporated into the Airworthiness Limitations chapter of this manual.
- (4) Operators are urged to keep informed of airworthiness information via Hartzell Propeller Inc. Service Bulletins and Service Letters, which are available from Hartzell Propeller Inc. distributors or from the Hartzell Propeller Inc. factory by subscription. Selected information is also available on Hartzell Propeller's website at www.hartzellprop.com.

E. Overhaul Periods

In flight, the propeller is constantly subjected to vibration from the engine and the airstream, as well as high centrifugal forces. The propeller is also subject to corrosion, as well as general deterioration due to aging. Under these conditions, metal fatigue or mechanical failures can occur. In order to protect your investment, and to maximize the safe operating lifetime of your propeller, it is essential that a propeller be properly maintained and overhauled according to the recommended service procedures.

CAUTION 1: OVERHAUL PERIODS LISTED BELOW, ALTHOUGH CURRENT AT THE TIME OF PUBLICATION, ARE FOR REFERENCE PURPOSES ONLY. OVERHAUL PERIODS MAY BE INCREASED OR DECREASED AS A RESULT OF ENGINEERING EVALUATION.

CAUTION 2: CHECK THE LATEST REVISION OF HARTZELL PROPELLER INC. SERVICE LETTER HC-SL-61-61Y FOR THE MOST CURRENT INFORMATION. THE SERVICE LETTER IS AVAILABLE ON THE HARTZELL PROPELLER INC. WEBSITE AT WWW.HARTZELLPROP.COM.

- (1) Hartzell Propeller Inc. steel hub propellers installed on turbine engine aircraft are to be overhauled at 3000 hours of operation or 60 calendar months, whichever occurs first.
- (2) Agricultural aircraft are to be overhauled at 3000 hours of operation or 36 calendar months, whichever occurs first.
 - (a) Once used on agricultural aircraft, the 36 month overhaul limit must be maintained until an overhaul is accomplished, even if the propeller is later installed on other category airplanes.

5. Inspection Procedures

CAUTION: INSTRUCTIONS AND PROCEDURES IN THIS SECTION MAY INVOLVE CRITICAL PARTS. REFER TO THE INTRODUCTION CHAPTER OF THIS MANUAL FOR INFORMATION ABOUT PROPELLER CRITICAL PARTS. REFER TO THE ILLUSTRATED PARTS LIST CHAPTER OF THE APPLICABLE OVERHAUL MANUAL(S) FOR THE IDENTIFICATION OF SPECIFIC PROPELLER CRITICAL PARTS.

The inspections detailed below are made on a regular basis, either before flight, during required periodic inspections, or if a problem is noted. Possible corrections to problems discovered during inspections, additional inspections, and limits are detailed in the following inspection procedures.

A. Blade Damage

Refer to Blade Repairs section in the Maintenance Practices chapter of this manual for information regarding blade damage.

B. Grease or Oil Leakage

WARNING: UNUSUAL OR ABNORMAL GREASE LEAKAGE OR VIBRATION, WHERE THE CONDITION STARTED SUDDENLY, CAN BE AN INDICATION OF A FAILING PROPELLER BLADE OR BLADE RETENTION COMPONENT. AN INFLIGHT BLADE SEPARATION CAN RESULT IN DEATH, SERIOUS BODILY INJURY, AND/OR SUBSTANTIAL PROPERTY DAMAGE. UNUSUAL OR ABNORMAL GREASE LEAKAGE OR VIBRATION REQUIRES IMMEDIATE INSPECTION FOR A POSSIBLE CRACKED BLADE OR BLADE RETENTION COMPONENT.

NOTE: A new or newly overhauled propeller may leak slightly during the first several hours of operation. This leakage may be caused by the seating of seals and O-rings, and the slinging of lubricants used during assembly. Such leakage should cease within the first ten hours of operation.

Leakage that persists beyond the first ten hours of operation on a new or newly overhauled propeller, or occurs on a propeller that has been in service for some time will require repair. A determination should be made as to the source of the leak. The only leakage that is field repairable is the removal and replacement of the O-ring seal between the engine and propeller flange. All other leakage repairs should be referred to an appropriately licensed propeller repair facility. An instance of abnormal grease leakage should be inspected following the procedure below:

(1) Remove the spinner dome.

CAUTION: PERFORM A VISUAL INSPECTION WITHOUT CLEANING THE PARTS. A TIGHT CRACK IS OFTEN EVIDENT DUE TO TRACES OF GREASE EMANATING FROM THE CRACK. CLEANING CAN REMOVE SUCH EVIDENCE AND MAKE A CRACK VIRTUALLY IMPOSSIBLE TO SEE.

(2) Perform a visual inspection of the blade clamps to locate the origin of leakage. If the origin of the grease leakage is determined to be a noncritical part, such as an O-ring, gasket or sealant, repairs can be accomplished during scheduled maintenance, as long as flight safety is not compromised.

(3) If cracks in the blade clamp are suspected, perform additional inspections before further flight (by qualified personnel at an appropriately licensed propeller repair facility) to verify the condition. Such inspections typically include disassembly of the propeller, followed by inspection of parts, using non-destructive methods in accordance with published procedures.

(4) If cracks or failing components are found, these parts must be replaced before further flight. Report such occurrences to airworthiness authorities and to Hartzell Propeller Inc. Product Support.

C. Vibration

Instances of abnormal vibration should be investigated immediately. If the cause of the vibration is not readily apparent, the propeller may be inspected following the procedure below:

NOTE: It may sometimes be difficult to readily identify the cause of abnormal vibration. Vibration may originate in the engine, propeller, or airframe. Troubleshooting procedures typically begin with an investigation of the engine. Airframe components, such as engine mounts or loose landing gear doors, can also be the source of vibration. When investigating an abnormal vibration, the possibility of a failing blade or blade retention component should be considered as a potential source of the problem.

- (1) Perform troubleshooting and evaluation of possible sources of vibration in accordance with engine or airframe manufacturer's instructions.
- (2) Refer to Vibration section in the Testing and Troubleshooting chapter of this manual. Perform the checks to determine possible cause of the vibration. If no cause is found, then consider the origin of the problem could be the propeller and proceed with steps 4.C.(3) through 4.C.(8).
- (3) Remove the spinner dome.
- (4) Perform a visual inspection for cracks in the hub, blade clamps and blades.

NOTE: A crack may be readily visible or may be indicated by grease leaking from a seemingly solid surface.

- (5) If cracks in the hub or the blade clamp are suspected, additional inspections must be performed before further flight. These inspections must be performed by qualified personnel at an appropriately licensed propeller repair facility to verify the condition. Such inspections typically include disassembly of the propeller followed by inspection of parts, using nondestructive methods in accordance with published procedures.

- (6) Check the blades and compare blade to blade differences:
 - (a) Inspect the propeller blades for unusual looseness or movement. Refer to Loose Blades in this chapter.
 - (b) Check blade track. Refer to Blade Track in this chapter.

CAUTION: DO NOT USE BLADE PADDLES TO TURN BLADES.

- (c) Manually (by hand) attempt to turn the blades (change pitch).
 - (d) Visually check for damaged blades.
- (7) If abnormal blade conditions or damage are found, perform additional inspections (by qualified personnel at an appropriately licensed propeller repair facility) to evaluate the condition. Refer to the Blade Repairs section in Maintenance Practices chapter of this manual.
- (8) If cracks or failing components are found, these parts must be replaced before further flight. Report such occurrences to airworthiness authorities and Hartzell Propeller Inc. Product Support.

D. Tachometer Inspection

WARNING: OPERATION WITH AN INACCURATE TACHOMETER MAY RESULT IN RESTRICTED RPM OPERATION AND DAMAGING HIGH STRESSES. BLADE LIFE WILL BE SHORTENED AND COULD RESULT IN CATASTROPHIC FAILURE.

- (1) Accuracy of the engine tachometer should be verified at 100 hour intervals or at annual inspection, whichever occurs first.
- (2) Hartzell Propeller Inc. recommends using a tachometer that is accurate within +/- 10 RPM, has NIST calibration (traceable), and has an appropriate calibration schedule.

I (This page is intentionally blank.)

W10144

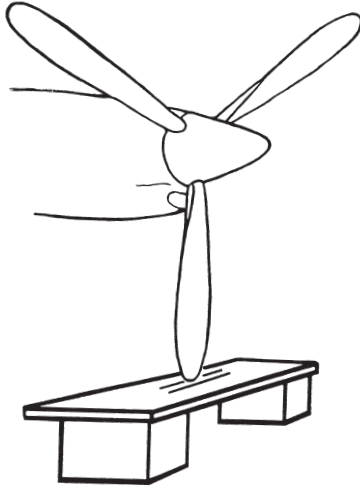

Checking Blade Track
Figure 5-1

W10143

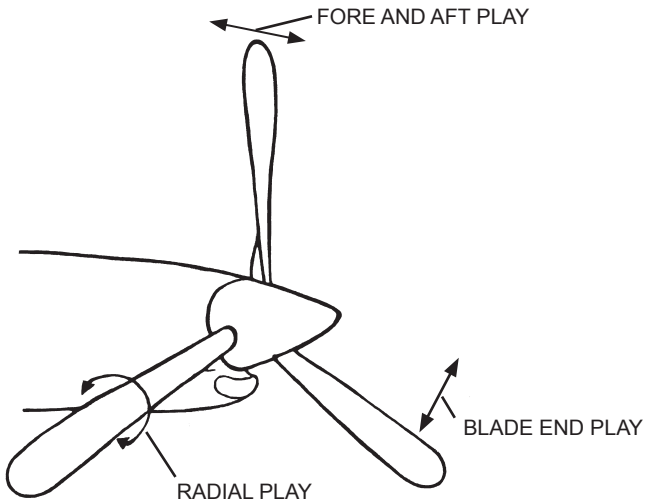

Blade Play
Figure 5-2

E. Blade Track

(1) On -2 and -5 propeller models only, check the blade track as follows:

- (a) Chock the aircraft wheels securely.
- (b) Refer to Figure 5-1. Place a fixed reference point beneath the propeller, within 0.25 inch (6.4 mm) of the lowest point of the propeller arc.

NOTE: This reference point may be a flat board with a sheet of paper attached to it. The board may then be blocked up to within 0.25 inch (6.4 mm) of the propeller arc.

- (c) Rotate the propeller by hand in the direction of normal rotation until a blade points directly at the paper. Mark the position of the blade tip in relation to the paper.
- (d) Repeat this procedure with the remaining blades.
- (e) Tracking tolerance is ± 0.062 inch (1.57 mm) or 0.125 inch (3.17 mm) total.

(2) On -3 and -7 propeller models only, the propeller must be removed from the aircraft to check the blade track on a rotatable fixture, in accordance with the applicable Hartzell Propeller Inc. Manual 118F (61-10-18) or 132A (61-10-32).

(3) Possible Correction

- (a) Remove any foreign matter from the propeller mounting flange.
- (b) If no foreign matter is present, refer to an appropriately licensed propeller repair facility.

F. Loose Blades

Refer to Figure 5-2. Limits for blade looseness are as follows:

End Play	± 0.06 inch (1.5 mm)
Fore & Aft Play	± 0.06 inch (1.5 mm)
Radial Play (pitch change)	± 0.5 degree (1 degree total) measured at reference station
In and Out	0.032 inch (0.81 mm)

NOTE: Blades are intended to be tight in the propeller; however, movement less than allowable limits is acceptable if the blade returns to its original position when released. Blades with movement greater than allowable limits, or that do not return to their original position when released may indicate internal wear or damage that should be referred to an appropriately licensed propeller repair station.

G. Corrosion

WARNING: REWORK THAT INVOLVES COLD WORKING THE METAL, RESULTING IN CONCEALMENT OF A DAMAGED AREA IS NOT PERMITTED.

Light corrosion on blades may be removed by qualified personnel in accordance with the Blade Repairs section in the Maintenance Practices chapter of this manual.

Heavy corrosion that results in severe pitting must be referred to an appropriately licensed propeller repair station.

H. Spinner Damage

Inspect the spinner for cracks, missing hardware, or other damage. Refer to an appropriately licensed propeller repair station for spinner damage acceptance and repair information. Contact the local airworthiness authority for repair approval.

I. Electric De-ice System

(1) Refer to the Anti-ice and De-ice Systems chapter of this manual for inspection procedures.

J. Anti-ice System

- (1) Refer to the Anti-ice and De-ice Systems chapter of this manual for inspection procedures.

6. Special Inspections

CAUTION: INSTRUCTIONS AND PROCEDURES IN THIS SECTION MAY INVOLVE CRITICAL PARTS. REFER TO THE INTRODUCTION CHAPTER OF THIS MANUAL FOR INFORMATION ABOUT PROPELLER CRITICAL PARTS. REFER TO THE ILLUSTRATED PARTS LIST CHAPTER OF THE APPLICABLE OVERHAUL MANUAL(S) FOR THE IDENTIFICATION OF SPECIFIC PROPELLER CRITICAL PARTS.

A. Overspeed/Overtorque

An overspeed has occurred when the propeller RPM has exceeded the maximum RPM stated in the applicable Aircraft Type Certificate Data Sheet. An overtorque condition occurs when the engine load exceeds the limits established by the engine, propeller, or airframe manufacturer. The duration of time at overspeed/overtorque for a single event determines the corrective action that must be taken to make sure no damage to the propeller has occurred.

The criteria for determining the required action after an overspeed are based on many factors. The additional centrifugal forces that occur during overspeed are not the only concern. Some applications have sharp increases in vibratory stresses at RPMs above the maximum rated for the airframe/engine/propeller combination

- (1) When a propeller installed on a turbine engine has an overspeed event, refer to the Turbine Engine Overspeed Limits (Figure 5-3) to determine the corrective action to be taken.
- (2) When a propeller installed on a turbine engine has an overtorque event, refer to the Turbine Engine Overtorque Limits (Figure 5-4) to determine the corrective action to be taken.
- (3) Make an entry in the propeller log book to document the overspeed/overtorque event.

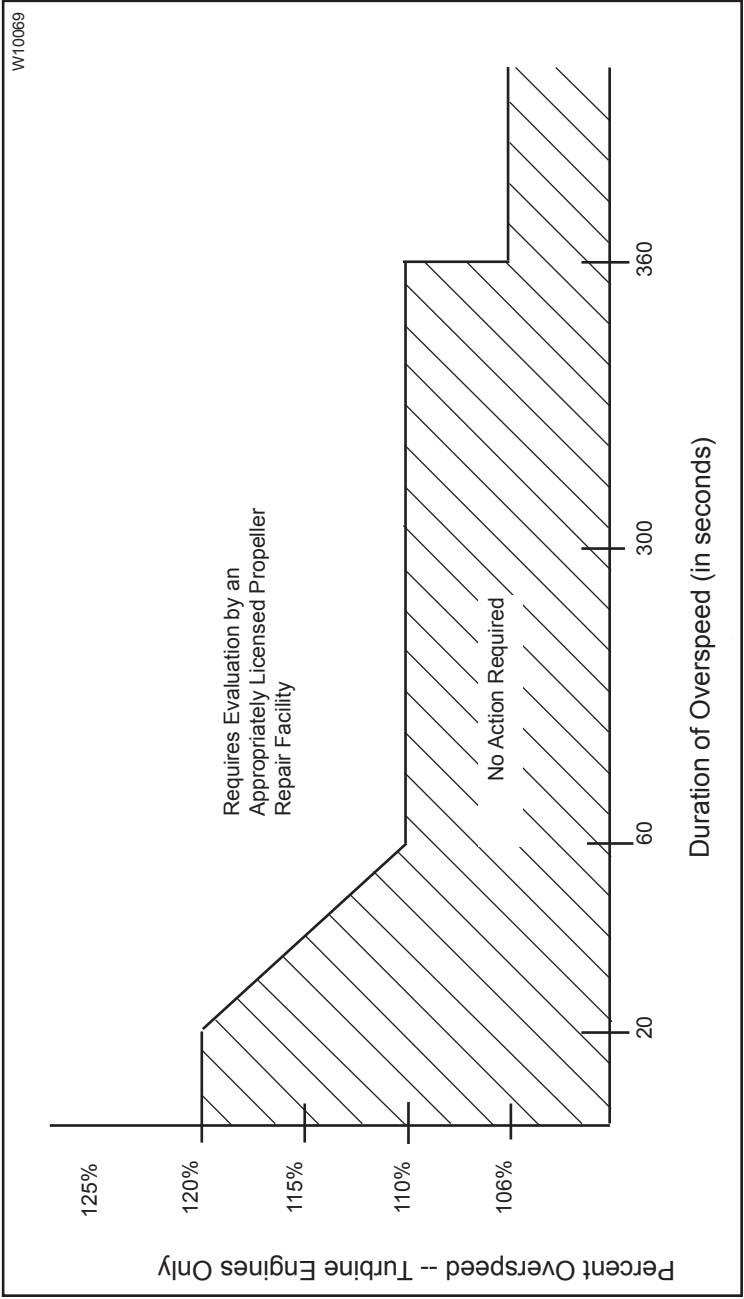

Turbine Engine Overspeed Limits
Figure 5-3

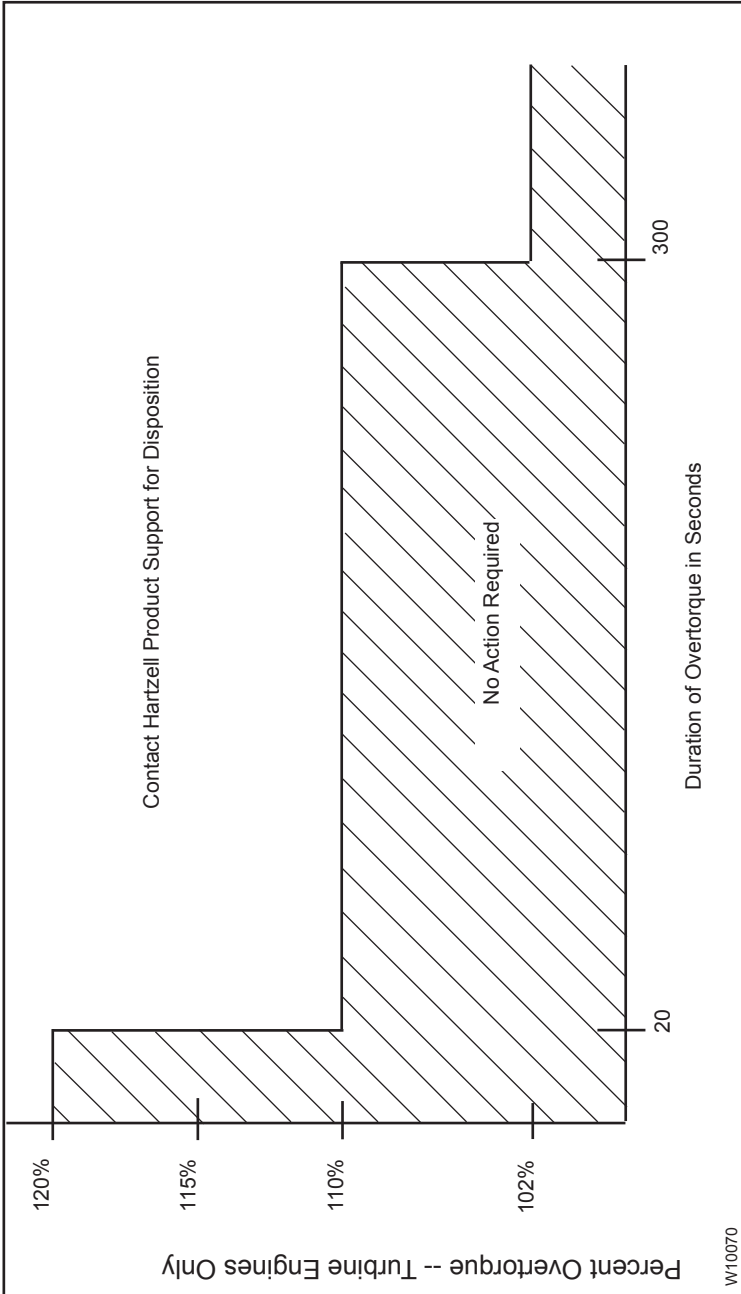

Turbine Engine Overtorque Limits
Figure 5-4

B. Propeller Ground Idle Operating Restrictions

WARNING: STABILIZED GROUND OPERATION WITHIN THE PROPELLER RESTRICTED RPM RANGE CAN GENERATE HIGH PROPELLER STRESSES AND RESULT IN FATIGUE DAMAGE TO THE PROPELLER. THIS DAMAGE CAN LEAD TO A REDUCED PROPELLER FATIGUE LIFE, PROPELLER FAILURE, AND LOSS OF CONTROL OF THE AIRCRAFT. THE PROPELLER RESTRICTED RPM RANGE IS DEFINED IN THE AIRPLANE FLIGHT MANUAL.

(1) General

- (a) The information in this section applies only to the four and five bladed propeller models that are addressed in this manual.
- (b) The information in this section is intended to emphasize the critical importance of correct propeller ground idle RPM on certain turboprop installations. It also defines the appropriate corrective action required when a propeller has been operated within this restricted RPM region.
- (c) If the propeller is operated within a restricted RPM range or below a minimum idle RPM restriction for an extended period of time, the propeller blades and hub can become unairworthy because of fatigue. A failed blade or hub has the potential to cause a catastrophic blade separation.
- (d) Four, five and six blade propellers operating on turbine engines can be sensitive to operation within restricted RPM ranges. These restricted ranges are usually in the lower RPM ranges, requiring that ground idle RPM be set above a critical minimum value.

Example:

Minimum propeller idle RPM listed in the AMM is 1180 RPM
Propeller idle is set at 1120 RPM
Propeller has operated with a RPM deviation of **60 RPM**
Engine was rigged 2 months ago and has operated **75 hours**
since it was rigged

Figure 5-6 shows that with an RPM deviation of 60 RPM for 75 hours - the propeller assembly must be overhauled and engine rigging corrected before further flight.

**Example of an Evaluation of Ground Idle RPM Check
Figure 5-5**

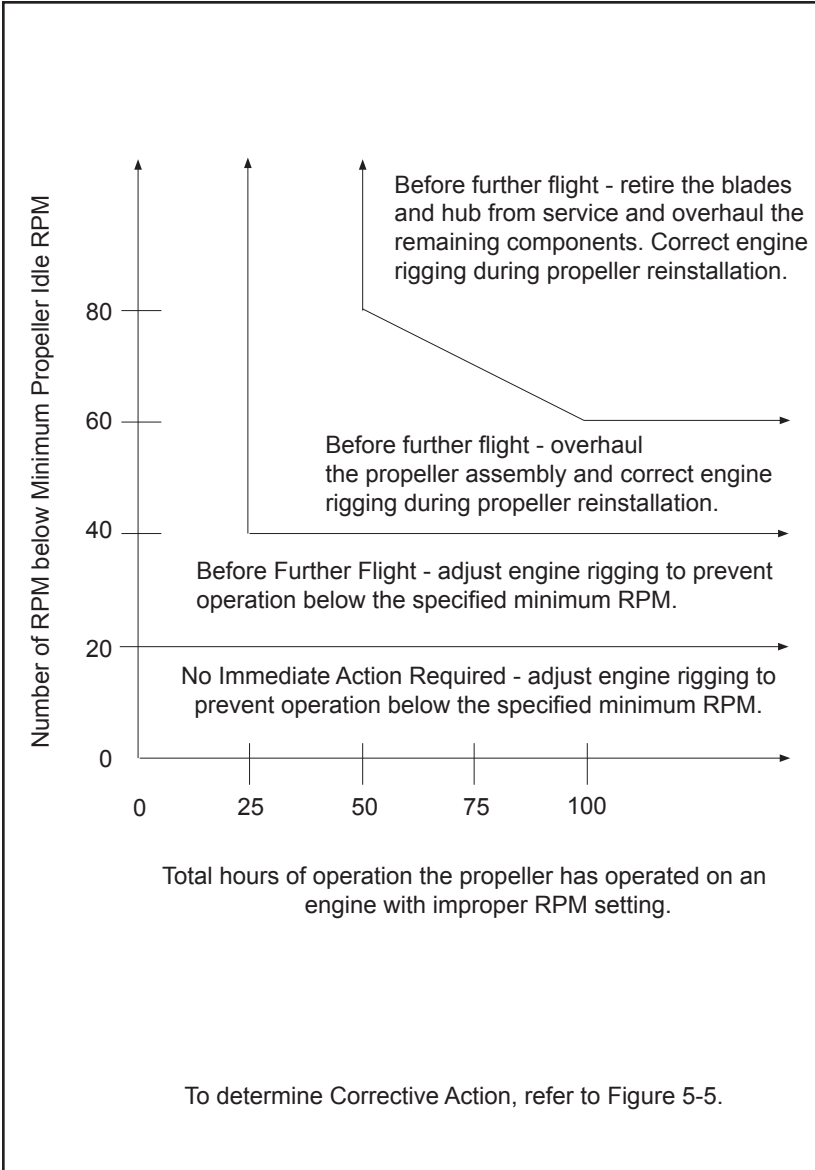

Corrective Action Required
Figure 5-6

- (e) This minimum propeller idle RPM operating restriction is the result of a specific vibratory resonant condition known as “reactionless mode”. During operation in these conditions the flight crew cannot feel the resulting high propeller vibration. Ground operation at or near an RPM that can create a reactionless mode vibratory resonance can cause very high stresses in the propeller blades and the hub. These high stresses are more severe when operating in a tailing wind condition.
- (2) Periodic Ground Idle RPM Check
- (a) Perform the RPM check, especially following engine rigging/idle RPM adjustments.
 - (b) Refer to the Airplane Flight Manual or Airplane Flight Manual Supplement to determine if there are any propeller RPM restrictions or limitations.
 - (c) Check the accuracy of the tachometer. Refer to the Tachometer Inspection section in this chapter.
 - (d) Perform an engine run up and determine if the engine and/or propeller rigging permits operation of the propeller below the minimum specified propeller idle RPM.
 - (e) If the propeller cannot be operated below the minimum specified propeller idle RPM, no further action is required.
 - (f) If the propeller can be operated below the minimum specified propeller idle RPM:
 - 1 Refer to Figure 5-6 for corrective action. Refer to Figure 5-5 for help when using Figure 5-6.

- 2 The corrective action is based on the amount the RPM is below the minimum propeller idle RPM and the total hours of operation the propeller has accumulated.
 - a Figure 5-6 applies to an aircraft that is operated in conventional service. "Hours of Operation" refers to the total number of hours the propeller is operated on an engine that has an improper RPM setting. It is not the number of hours the propeller is operated in a restricted range, which will be less than the total hours of operation.
- (3) Corrective Action
- (a) The required corrective action is determined by both the amount and duration of RPM deviation.
 - 1 A turboprop propeller with four or more blades may have a variety of operating restrictions and these different restrictions may have different operating margins.
 - 2 The greater the amount of the RPM deviation and the longer it is permitted to exist, the more severe the required corrective action.
 - 3 The corrective action may vary from no action required to scrapping of the blades and the hub.
 - 4 Refer to Figure 5-6 for the required corrective action.
 - 5 Contact Hartzell Propeller Inc. if further clarification is required.
 - 6 If a propeller restriction other than those described in Figure 5-6 has been violated, contact Hartzell Propeller Inc.
 - a The chart in Figure 5-6 applies only to operation below the minimum idle RPM.
 - b The chart in Figure 5-6 does not apply to other propeller restrictions that are above the minimum idle RPM.

- 7 If the corrective action requires a propeller overhaul, overhaul the propeller in accordance with the applicable propeller overhaul manuals.
- 8 If the corrective action requires that the blades and the hub be retired from service, retire these components from service in accordance with the Part Retirement Procedures chapter of Hartzell Propeller Inc. Standard Practices Manual 202A (61-01-02).
- 9 A propeller hub or blade that has been retired from service because of a violation of the operating restrictions as specified in this section must not be reused on another aircraft application.
- 10 If the corrective action requires the correction of the propeller RPM setting, refer to the applicable installation and rigging instructions for the adjustment of engine torque, engine idle speed, and propeller RPM setting.
- 11 Contact Hartzell Propeller Inc. Product Support Department to report the findings.
Hartzell Propeller Inc.
One Propeller Place
Piqua, Ohio 45356-2634 USA
Phone: 937.778.4379
Fax: 937.778.4391
E-mail: techsupport@hartzellprop.com

C. Lightning Strike

CAUTION: ALSO CONSULT ENGINE AND AIRFRAME MANUFACTURER'S MANUALS. THERE MAY BE ADDITIONAL REQUIREMENTS, SUCH AS DE-ICE AND ENGINE SYSTEM CHECKS TO PERFORM AFTER A PROPELLER LIGHTNING STRIKE.

(1) General

In the event of a propeller lightning strike, an inspection is required before further flight. It may be permissible to operate a propeller for an additional ten (10) hours of operation if the propeller is not severely damaged and meets the requirements in Procedure for Temporary Operation in this section. Regardless of the outcome of the initial inspection, the propeller must eventually be removed from the aircraft, disassembled, evaluated, and/or repaired by an appropriately licensed propeller repair facility.

(2) Procedure for Temporary Operation

If temporary additional operation is desired before propeller removal and disassembly:

- (a) Remove spinner dome and perform visual inspection of propeller, spinner, and de-ice system for evidence of significant damage that would require repair before flight (such as broken de-ice wires or arcing damage to propeller hub, blades, or blade clamps).

CAUTION: IF THE PROPELLER EXPERIENCES A LIGHTNING STRIKE, THE ALUMINUM BLADES MUST BE WITHIN AIRWORTHY LIMITS FOR ANY ADDITIONAL FLIGHT.

- (b) If the only evident damage is minor arcing burns to the blades, then operation for ten (10) hours is acceptable before disassembly and inspection.
- (c) Perform a functional check of the propeller de-ice system (if installed) in accordance with aircraft maintenance manual procedures.

- (d) Regardless of the degree of damage, make a log book entry to document the lightning strike.
- (e) The propeller must be removed from the aircraft, disassembled, evaluated, and/or repaired by an appropriately licensed propeller repair facility for flight beyond the temporary operation limits granted above.

D. Foreign Object Strike

(1) General

- (a) A foreign object strike can include a broad spectrum of damage, from a minor stone nick to severe ground impact damage. A conservative approach in evaluating the damage is required because there may be hidden damage that is not readily apparent during an on-wing, visual inspection.
- (b) A foreign object strike is defined as:
 - 1 Any incident, whether or not the engine is operating, that requires repair to the propeller other than minor dressing of the blades. Examples of foreign object strike include situations where an aircraft is stationary and the landing gear collapses, causing one or more blades to be significantly damaged, or where a hangar door (or other object) strikes the propeller blade. These cases should be handled as foreign object strikes because of potentially severe side loading on the propeller hub, clamps, blades and retention bearings.
 - 2 Any incident during engine operation in which the propeller impacts a solid object that causes a drop in revolutions per minute (RPM) and also requires structural repair of the propeller (incidents requiring only paint touch-up are not included). This is not restricted to propeller strikes against the ground.
 - 3 A sudden RPM drop while impacting water, tall grass, or similar yielding medium, where propeller blade damage is not normally incurred.

(2) Procedure

- (a) In the event of a foreign object strike/ground strike, an inspection is required before further flight. If the inspection reveals one or more of the following indications, the propeller must be removed from the aircraft, disassembled and overhauled in accordance with the applicable propeller and blade maintenance manuals.
- 1 A blade rotated in the clamp
 - 2 Any noticeable or **suspected** damage to the pitch change mechanism
 - 3 A bent blade (out of track or angle).
 - 4 Any diameter reduction
 - 5 Blade damage
 - 6 A bent, cracked, or failed engine shaft
 - 7 Vibration during operation
- (b) Nicks, gouges, and scratches on blade surfaces or the leading and trailing edges must be removed before flight. Refer to the Blade Repairs section in the Maintenance Practices chapter of this manual.
- (c) Engine mounted components such as governors, pumps, etc. may be damaged by a foreign object strike/ground strike, especially if the strike resulted in a sudden stoppage of the engine. These components should be inspected, repaired, or overhauled as recommended by the applicable component maintenance manual.
- (d) Make a log book entry to document the foreign object strike/ground strike incident and any corrective action(s) taken.

E. Fire Damage or Heat Damage

WARNING: HUBS AND CLAMPS ARE MANUFACTURED FROM HEAT TREATED FORGINGS AND ARE SHOT PEENED. BLADES ARE MANUFACTURED FROM HEAT TREATED FORGINGS AND ARE COMPRESSIVELY ROLLED AND SOMETIMES SHOT PEENED. EXPOSURE TO HIGH TEMPERATURES CAN DESTROY THE FATIGUE RESISTANCE BENEFITS OBTAINED FROM THESE PROCESSES.

On rare occasions propellers may be exposed to fire or heat damage, such as an engine or hangar fire. In the event of such an incident, an inspection by an appropriately licensed propeller repair facility is required before further flight.

7. Long Term Storage

CAUTION: INSTRUCTIONS AND PROCEDURES IN THIS SECTION MAY INVOLVE CRITICAL PARTS. REFER TO THE INTRODUCTION CHAPTER OF THIS MANUAL FOR INFORMATION ABOUT PROPELLER CRITICAL PARTS. REFER TO THE ILLUSTRATED PARTS LIST CHAPTER OF THE APPLICABLE OVERHAUL MANUAL(S) FOR THE IDENTIFICATION OF SPECIFIC PROPELLER CRITICAL PARTS.

Parts shipped from the Hartzell Propeller Inc. factory are not shipped or packaged in a container that is designed for long term storage.

Long term storage procedures may be obtained by contacting a Hartzell Propeller Inc. distributor, or the Hartzell Propeller Inc. factory via the Product Support number listed in the Introduction chapter of this manual. Storage information is also detailed in Hartzell Propeller Inc. Manual 202A (61-01-02).

Information regarding the return of a propeller assembly to service after long term storage may be obtained by contacting a Hartzell Propeller Inc. distributor or RRF, or the Hartzell Propeller Inc. factory via the product support number listed in the Introduction chapter of this manual. This information is also detailed in Hartzell Propeller Inc. Manual 202A (61-01-02).

MAINTENANCE PRACTICES - CONTENTS

1. Cleaning	6-3
A. General Cleaning.....	6-3
B. Spinner Cleaning and Polishing.....	6-5
2. Lubrication.....	6-5
A. Lubrication Intervals.....	6-5
B. Lubrication Procedure.....	6-6
C. Approved Lubricants.....	6-8
3. Carbon Block Assemblies	6-9
A. Inspection	6-9
B. Replacement of A-3026 Carbon Block Unit in the A-3044 Carbon Block Assembly.....	6-9
C. Installation of the A-3044 Carbon Block Assembly	6-10
4. Blade Repairs.....	6-11
A. Repair of Nicks and Gouges.....	6-13
B. Repair of Bent Blades.....	6-15
5. Painting After Repair	6-16
A. Painting of Aluminum Blades.....	6-18
6. Dynamic Balance	6-20
A. Overview.....	6-20
B. Inspection Procedures Before Balancing.....	6-21
C. Modifying Spinner Bulkhead to Accommodate Dynamic Balance Weights.....	6-21
D. Placement of Balance Weights for Dynamic Balance.....	6-22
7. Propeller Ice Protection Systems	6-23
A. Electric De-ice System.....	6-23
B. Anti-ice System.....	6-23

MAINTENANCE PRACTICES - FIGURES

Grease Fitting Figure 6-1 6-4
Lubrication Label Figure 6-2 6-7
Repair Limitations..... Figure 6-3 6-12

MAINTENANCE PRACTICES - TABLES

Approved Touch-up Paints Table 6-1 6-17



1. Cleaning

CAUTION 1: INSTRUCTIONS AND PROCEDURES IN THIS SECTION MAY INVOLVE CRITICAL PARTS. REFER TO THE INTRODUCTION CHAPTER OF THIS MANUAL FOR INFORMATION ABOUT PROPELLER CRITICAL PARTS. REFER TO THE ILLUSTRATED PARTS LIST CHAPTER OF THE APPLICABLE OVERHAUL MANUAL(S) FOR THE IDENTIFICATION OF SPECIFIC PROPELLER CRITICAL PARTS.

CAUTION 2: DO NOT USE PRESSURE WASHING EQUIPMENT TO CLEAN THE PROPELLER OR CONTROL COMPONENTS. PRESSURE WASHING CAN FORCE WATER AND/OR CLEANING SOLVENTS PAST SEALS, AND CAN LEAD TO INTERNAL CORROSION OF PROPELLER COMPONENTS.

A. General Cleaning

CAUTION 1: WHEN CLEANING THE PROPELLER, DO NOT ALLOW SOAP OR SOLVENT SOLUTIONS TO RUN OR SPLASH INTO THE HUB AREA.

CAUTION 2: DO NOT CLEAN PROPELLER WITH CAUSTIC OR ACIDIC SOAP SOLUTIONS. IRREPARABLE CORROSION OF PROPELLER COMPONENTS MAY OCCUR.

(1) Wash propeller with a noncorrosive soap solution.

CAUTION: DO NOT USE ANY SOLVENT DURING CLEANING THAT COULD SOFTEN OR DESTROY THE BOND BETWEEN CHEMICALLY ATTACHED PARTS.

(2) To remove grease or oil from propeller surfaces, apply Stoddard Solvent or equivalent to a clean cloth and wipe the part clean.

(3) Thoroughly rinse with water and allow to dry.

D-1490,PLT

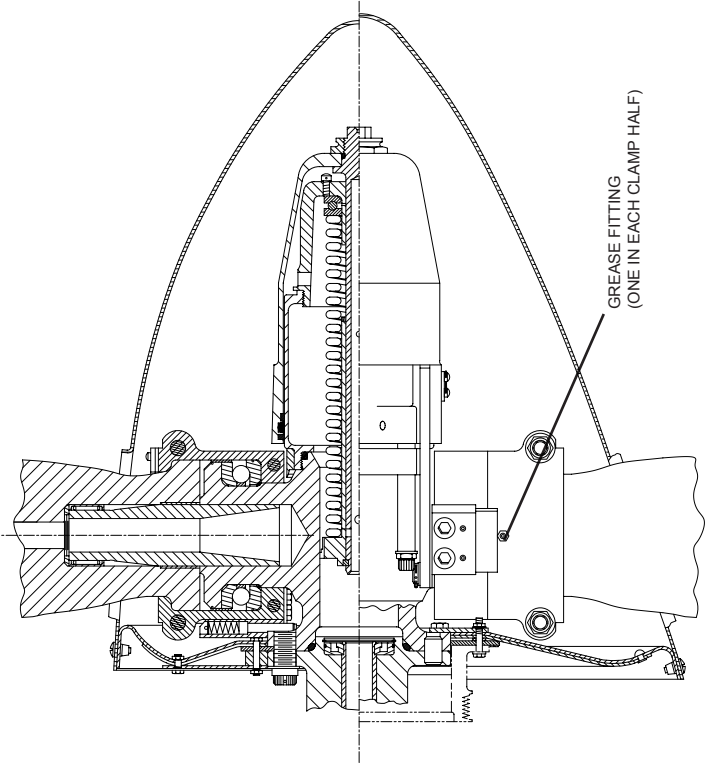

**Grease Fitting
Figure 6-1**

B. Spinner Cleaning and Polishing

- (1) Clean the spinner using the General Cleaning procedures in this section.
- (2) Polish the dome (if required) with an automotive type aluminum polish.

2. Lubrication

CAUTION: INSTRUCTIONS AND PROCEDURES IN THIS SECTION MAY INVOLVE CRITICAL PARTS. REFER TO THE INTRODUCTION CHAPTER OF THIS MANUAL FOR INFORMATION ABOUT PROPELLER CRITICAL PARTS. REFER TO THE ILLUSTRATED PARTS LIST CHAPTER OF THE APPLICABLE OVERHAUL MANUAL(S) FOR THE IDENTIFICATION OF SPECIFIC PROPELLER CRITICAL PARTS.

A. Lubrication Intervals

- (1) The propeller is to be lubricated at intervals not to exceed 200 hours or at 12 calendar months, whichever occurs first.

NOTE 1: If annual operation is significantly less than 100 hours, calendar lubrication intervals should be reduced to six months.

NOTE 2: If the aircraft is operated or stored under adverse atmospheric conditions, e.g., high humidity, salt air, calendar lubrication intervals should be reduced to 100 hours or six months.

NOTE 3: If the propeller is operated on a seaplane, the lubrication interval should be reduced to 100 hours or six months.

NOTE 4: If the propeller is leaking grease, the lubrication interval should be reduced to 100 hours until the grease leak issue is resolved.

- (2) Owners of high use aircraft may wish to extend their lubrication intervals. Lubrication interval may be gradually extended after evaluation of previous propeller overhauls, with regard to bearing wear and internal corrosion.

- (3) New or newly overhauled propellers should be lubricated after the first one or two hours of operation, because centrifugal loads will pack and redistribute grease.

NOTE: Purchasers of new aircraft should check the propeller logbook to verify whether the propeller was lubricated by the manufacturer during flight testing. If not, the propeller should be serviced at earliest convenience.

B. Lubrication Procedure

CAUTION: FOLLOW LUBRICATION PROCEDURES CORRECTLY TO MAINTAIN AN ACCURATE BALANCE OF THE PROPELLER ASSEMBLY.

- (1) Remove the propeller spinner.
- (2) Refer to Figure 6-1. Each blade clamp has two lubrication fittings. Remove both lubrication fitting caps and one of the lubrication fittings from each blade clamp.
- (3) Use a piece of safety wire to loosen any blockage or hardened grease in the threaded holes where the lubrication fitting was removed.

WARNING: WHEN MIXING AEROSHELL GREASES 5 AND 6, AEROSHELL GREASE 5 MUST BE INDICATED ON THE LABEL (HARTZELL PROPELLER INC. P/N A-3594) AND THE AIRCRAFT MUST BE PLACARDED TO INDICATE THAT FLIGHT IS PROHIBITED IF THE OUTSIDE AIR TEMPERATURE IS LESS THAN -40°F (-40°C).

CAUTION: USE HARTZELL PROPELLER INC. PROPELLER APPROVED GREASE ONLY. EXCEPT IN THE CASE OF AEROSHELL GREASES 5 AND 6, DO NOT MIX DIFFERENT SPECIFICATIONS AND/OR BRANDS OF GREASE.

- (4) Aeroshell greases 5 and 6 both have a mineral oil base and have the same thickening agent; therefore, mixing of these two greases is acceptable in Hartzell Propeller Inc. propellers.

- (5) A label (Hartzell Propeller Inc. P/N A-3494) is normally applied to the propeller to indicate the type of grease previously used (Figure 6-2).
 - (a) This grease type should be used during re-lubrication unless the propeller has been disassembled and the old grease removed.
 - (b) Purging of old grease through lubrication fittings is only about 30 percent effective.
 - (c) To completely replace one grease with another, the propeller must be disassembled in accordance with the applicable overhaul manual.

CAUTION 1: IF A PNEUMATIC GREASE GUN IS USED, EXTRA CARE MUST BE TAKEN TO AVOID EXCESSIVE PRESSURE BUILDUP.

CAUTION 2: GREASE MUST BE APPLIED TO ALL BLADES OF A PROPELLER ASSEMBLY AT THE TIME OF LUBRICATION.

- (6) Pump grease into the blade clamp grease fitting until grease emerges from the hole of the removed lubrication fitting.

NOTE: Lubrication is complete when grease emerges in a steady flow with no air pockets or moisture, and has the color and texture of the new grease.

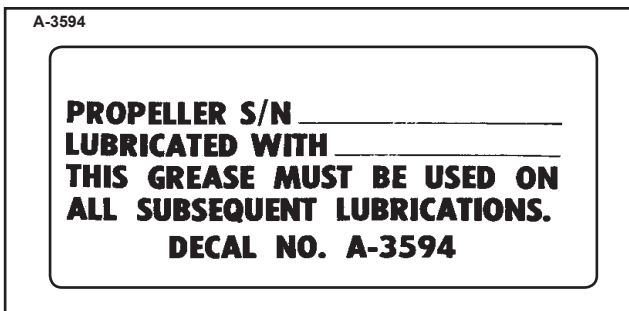

Lubrication Label
Figure 6-2

- (7) Repeat step 2.B.(4) for each blade clamp assembly.
- (8) Reinstall the removed lubrication fitting on each clamp.
- (9) Tighten the lubrication fittings until snug.
 - (a) Make sure the ball of each lubrication fitting is properly seated.
- (10) Reinstall a lubrication cap on each lubrication fitting.

C. Approved Lubricants

- (1) The following lubricants are approved for use in Hartzell Propeller Inc. propellers:

Aeroshell 6 - Recommended all purpose grease. Used in most new production propellers since 1989. Higher leakage/oil separation than Aeroshell 5 at higher temperatures.

Aeroshell 5 - Good high temperature qualities, very little oil separation or leakage. Cannot be used in temperatures colder than 40°F (-40°C). Aircraft serviced with this grease must be placarded to indicate that flight is prohibited if the outside air temperature is less than -40°F (-40°C).

Aeroshell 7 - Good low temperature grease, but high leakage/oil separation at higher temperatures. This grease has been associated with sporadic problems involving seal swelling.

Aeroshell 22 - Qualities similar to Aeroshell 7.

Royco 22CF - Not widely used. Qualities similar to Aeroshell 22.

- (2) A label indicating the type of grease used for previous lubrication (if used) is installed on the propeller piston or on the blade clamp. If the propeller must be lubricated with a different type of grease, the propeller must be disassembled and cleaned of old grease before relubricating.

3. Carbon Block Assemblies

CAUTION: INSTRUCTIONS AND PROCEDURES IN THIS SECTION MAY INVOLVE CRITICAL PARTS. REFER TO THE INTRODUCTION CHAPTER OF THIS MANUAL FOR INFORMATION ABOUT PROPELLER CRITICAL PARTS. REFER TO THE ILLUSTRATED PARTS LIST CHAPTER OF THE APPLICABLE OVERHAUL MANUAL(S) FOR THE IDENTIFICATION OF SPECIFIC PROPELLER CRITICAL PARTS.

A. Inspection

The clearance between the yoke pin and the corresponding linkage (beta lever bushing) can become too close due to a buildup of plating and foreign particles between the two pieces. This can cause a binding action, resulting in excessive wear to the carbon block, beta ring, and beta linkage.

- (1) Inspect the beta lever and carbon block interface for free movement. If there is binding, do the following:
 - (a) Disconnect the beta linkage and remove the carbon block assemblies from the beta ring.
 - (b) Using an abrasive pad, lightly polish the yoke pin to provide adequate clearance and eliminate binding.
 - (c) Reinstall the carbon block assembly into the beta ring.
 - (d) Install, adjust and safety the beta linkage per the airframe manufacturer's instructions.

B. Replacement of A-3026 Carbon Block Unit in the A-3044 Carbon Block Assembly

Replace an A-3026 carbon block unit if the side clearance between the beta ring and carbon block exceeds 0.010 inch (0.25 mm).

- (1) Remove the cotter pin from the end of the clevis pin.
- (2) Slide the pin from the assembly and remove and discard the carbon block unit.
- (3) Inspect the yoke for wear or cracks. Replace the yoke if necessary.

- (4) Install a new carbon block unit and slide a new clevis pin into place.
 - (5) Secure the clevis pin with a T-head cotter pin (Figure 3-7).
 - (6) Refit the carbon block (Figure 3-6).
 - (a) Establish the required clearance by sanding the sides of the carbon block as needed.
- C. Installation of the A-3044 Carbon Block Assembly
Refer to Installation and Removal Chapter of this manual for installation instructions.

4. Blade Repairs

WARNING: ALL NICKS, GOUGES, OR SCRATCHES OF ANY SIZE CAN CREATE A STRESS RISER THAT COULD POTENTIALLY LEAD TO BLADE CRACKING. ALL DAMAGE SHOULD BE VISUALLY EXAMINED CAREFULLY BEFORE FLIGHT FOR THE PRESENCE OF CRACKS OR OTHER ABNORMALITIES.

CAUTION 1: INSTRUCTIONS AND PROCEDURES IN THIS SECTION MAY INVOLVE PROPELLER CRITICAL PARTS. REFER TO THE INTRODUCTION CHAPTER OF THIS MANUAL FOR INFORMATION ABOUT PROPELLER CRITICAL PARTS. REFER TO THE ILLUSTRATED PARTS LIST CHAPTER OF THE APPLICABLE OVERHAUL MANUAL(S) FOR THE IDENTIFICATION OF SPECIFIC PROPELLER CRITICAL PARTS.

CAUTION 2: BLADES THAT HAVE BEEN PREVIOUSLY REPAIRED OR OVERHAULED MAY HAVE BEEN DIMENSIONALLY REDUCED. BEFORE REPAIRING SIGNIFICANT DAMAGE OR MAKING REPAIRS ON BLADES THAT ARE APPROACHING SERVICEABLE LIMITS, CONTACT AN APPROPRIATELY LICENSED PROPELLER REPAIR FACILITY OR THE HARTZELL PROPELLER INC. PRODUCT SUPPORT DEPARTMENT FOR BLADE DIMENSIONAL LIMITS.

Nicks, gouges, and scratches on blade surfaces or on the leading or trailing edges of the blade, greater than 0.031 inch (0.79 mm) wide or deep, must be removed before flight. Field repair of small nicks and scratches may be performed by qualified personnel in accordance with FAA Advisory Circular 43.13-1B, as well as the procedures specified below. Normal blade lead edge erosion (sand-blasted appearance) is acceptable, and does not require removal before further flight.

APS6157A

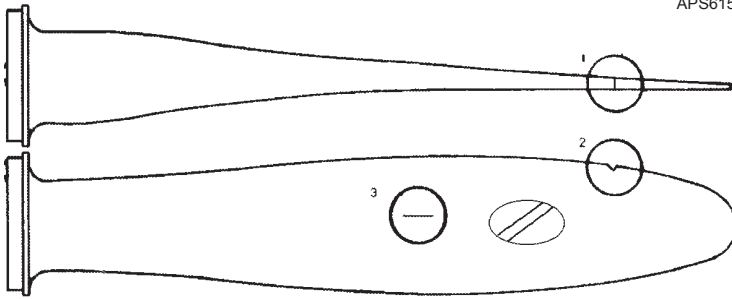

Example 1

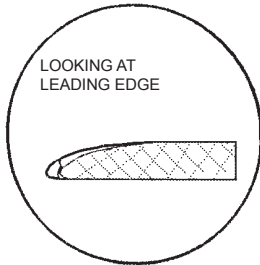

Example 2

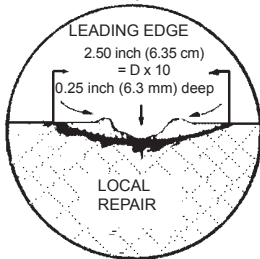

Example 3

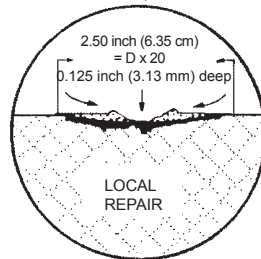

To determine amount of rework needed, use the following formula:

On the leading and trailing edge of the blade, measure the depth of the damage, and multiply this number $\times 10$ (see Example 2, above). Rework the area surrounding the damage 10 times the depth of the damage.

On the face and camber of the blade, measure the depth of the damage, and multiply this number $\times 20$ (see Example 3, above). Rework the area surrounding the damage 20 times the depth of the damage.

Repair Limitations

Figure 6-3

A. Repair of Nicks and Gouges

- (1) Local repairs may be made using files, electrical or air powered equipment. Emery cloth, Scotch Brite®, and crocus cloth are to be used for final finishing. Refer to Figure 6-3.

CAUTION 1: REWORK THAT INVOLVES COLD WORKING THE METAL, RESULTING IN CONCEALMENT OF A DAMAGED AREA, IS NOT PERMITTED. A STRESS CONCENTRATION MAY EXIST, WHICH CAN RESULT IN A BLADE FAILURE.

CAUTION 2: SHOT PEENED BLADES ARE IDENTIFIED WITH AN "S" FOLLOWING THE BLADE MODEL NUMBER, AS DESCRIBED IN THE DESCRIPTION AND OPERATION CHAPTER OF THIS MANUAL. BLADES THAT HAVE DAMAGE IN THE SHOT PEENED AREAS IN EXCESS OF 0.015 INCH (0.38 mm) DEEP ON THE FACE OR CAMBER OR 0.250 INCH (6.35 MM) ON THE LEADING OR TRAILING EDGES MUST BE REMOVED FROM SERVICE, AND THE REWORKED AREA SHOT PEENED BEFORE FURTHER FLIGHT. SHOT PEENING OF AN ALUMINUM BLADE MUST BE ACCOMPLISHED BY AN FAA APPROVED REPAIR FACILITY IN ACCORDANCE WITH HARTZELL PROPELLER INC. ALUMINUM BLADE MANUAL 133C (61-13-33).

- (2) Repairs to the leading or trailing edge are to be accomplished by removing material from the bottom of the damaged area. Remove material from this point out to both sides of the damage, providing a smooth, blended depression which maintains the original airfoil general shape.
- (3) Repairs to the blade face or camber should be made in the same manner as above. Repairs that form a continuous line across the blade section (chordwise) are unacceptable.

- (4) The area of repair should be determined as follows:
Leading and trailing edge damage: Depth of nick x 10.
Face and camber: Depth of nick x 20. Refer to Figure 6-3.

NOTE: Leading edge includes the first 10 percent of chord from the leading edge. The trailing edge consists of the last 20 percent of chord adjacent to the trailing edge.

- (5) After filing or sanding of the damaged area, the area must then be polished with emery cloth, Scotch Brite®, and finally with crocus cloth to remove any traces of filing.
- (6) Inspect the repaired area with a 10X magnifying glass. Make sure that no indication of the damage, file marks, or coarse surface finish remain.
- (7) If inspections show any remaining blade damage, repeat steps A.(5) and A.(6) of this chapter until no damage remains. Dye penetrant inspection is recommended in accordance with the Hartzell Standard Practices Manual 202A, (61-01-02) .
- (8) Treat the repaired area to prevent corrosion. Properly apply chemical conversion coating and approved paint to the repaired area before returning the blade to service. Refer to Painting After Repair in this section.

B. Repair of Bent Blades

CAUTION: DO NOT ATTEMPT TO "PRE-STRAIGHTEN" A BLADE BEFORE DELIVERY TO AN APPROPRIATELY LICENSED PROPELLER REPAIR FACILITY. THIS WILL CAUSE THE BLADE TO BE SCRAPPED BY THE REPAIR FACILITY.

- (1) Repair of a bent blade or blades is considered a major repair. This type of repair must be accomplished by an appropriately licensed propeller repair facility, and only within approved guidelines.

5. Painting After Repair

CAUTION: INSTRUCTIONS AND PROCEDURES IN THIS SECTION MAY INVOLVE CRITICAL PARTS. REFER TO THE INTRODUCTION CHAPTER OF THIS MANUAL FOR INFORMATION ABOUT PROPELLER CRITICAL PARTS. REFER TO THE ILLUSTRATED PARTS LIST CHAPTER OF THE APPLICABLE OVERHAUL MANUAL(S) FOR THE IDENTIFICATION OF SPECIFIC PROPELLER CRITICAL PARTS.

Propeller blades are painted with a durable specialized coating that is resistant to abrasion. If this coating becomes eroded, it is necessary to repaint the blades to provide proper corrosion and erosion protection. Painting should be performed by qualified personnel at an appropriately licensed propeller repair facility in accordance with Hartzell Propeller Inc. Standard Practices Manual 202A (61-01-02).

It is permissible to perform a blade touch-up with aerosol paint in accordance with the procedures in Painting of Aluminum Blades in this chapter.

Refer to Table 6-1 for paints approved for blade touch-up.

The paint manufacturers may be contacted via the information below:

Tempo Products Co.

A plasti-kote Company
1000 Lake Road
Medina, OH 44256
Tel: 800.321.6300
Fax: 216.349.4241
Cage Code: 07708

Sherwin Williams Co.

2390 Arbor Boulevard
Dayton, Ohio
Tel: 937.298.8691
Fax: 937.298.3820
Cage Code: 0W199

Vendor	Color	Vendor P/N	Hartzell Propeller Inc. P/N
Tempo	Epoxy Black	A-150	A-6741-145-2
Tempo	Epoxy Gray	A-151	A-6741-146-2
Tempo	Epoxy White (tip stripe)	A-152	A-6741-147-2
Tempo	Epoxy Red (tip stripe)	A-153	A-6741-149-2
Tempo	Epoxy Yellow (tip stripe)	A-154	A-6741-150-2
Sherwin-Williams	Black	F75KXB9958-4311	A-6741-145-1
Sherwin-Williams	Gray	F75KXA10445-4311	A-6741-146-1
Sherwin-Williams	White (tip stripe)	F75KXW10309-4311	A-6741-147-1
Sherwin-Williams	Gray Metallic	F75KXM9754-4311	A-6741-148-1
Sherwin-Williams	Red (tip stripe)	F75KXR12320-4311	A-6741-149-1
Sherwin-Williams	Yellow (tip stripe)	F75KXY11841-4311	A-6741-150-1
Sherwin-Williams	Silver	F75KXS13564-4311	A-6741-190-1
Sherwin-Williams	Bright Red	F63TXR16285-4311	A-6741-200-5
Sherwin-Williams	Bright Yellow	F63TXY16286-4311	A-6741-201-5
Sherwin-Williams	Bright Silver	F63TXS16768-4311	A-6741-203-5
Sherwin-Williams	Prop Gold	F63TXS17221-4311	A-6741-204-5

**Approved Touch-up Paints
Table 6-1**

A. Painting of Aluminum Blades

WARNING: CLEANING AGENTS (ACETONE, #700 LACQUER THINNER, AND MEK), ARE FLAMMABLE AND TOXIC TO THE SKIN, EYES, AND RESPIRATORY TRACT. SKIN AND EYE PROTECTION ARE REQUIRED. AVOID PROLONGED CONTACT. USE IN WELL VENTILATED AREA.

CAUTION: ANY REFINISHING PROCEDURE CAN ALTER PROPELLER BALANCE. PROPELLERS THAT ARE OUT OF BALANCE MAY EXPERIENCE EXCESSIVE VIBRATIONS WHILE IN OPERATION.

- (1) Using acetone, #700 lacquer thinner, or MEK, wipe the surface of the blade to remove any contaminants.
- (2) Feather the existing coatings away from the eroded or repaired area with 120 to 180 grit sandpaper.

NOTE: Paint erosion is typically very similar on all blades in a propeller assembly. If one blade has more extensive paint erosion, e.g., in the tip area, all the blades should be sanded in the tip area to replicate the repair of the most severely damaged blade tip. This practice is essential in maintaining balance after refinishing.

- (3) Use acetone, #700 lacquer thinner or MEK to wipe the surface of the blade. Allow solvent to evaporate.
- (4) Before refinishing the blades, apply an approved corrosion preventive coating to the bare aluminum surface. Oakite 31, Chromicote L-25, or Alodine 1201 are approved chemical conversion coatings. Apply these coatings in accordance with the directions provided by the product manufacturer.
- (5) Apply masking material for the de-ice boot and tip stripes, as needed.

WARNING: FINISH COATINGS ARE FLAMMABLE AND TOXIC TO THE SKIN, EYES, AND RESPIRATORY TRACT. SKIN AND EYE PROTECTION ARE REQUIRED. AVOID PROLONGED CONTACT. USE IN WELL VENTILATED AREA.

CAUTION: APPLY ENOUGH FINISH COATING ONLY TO UNIFORMLY COVER THE REPAIR/ EROSION. AVOID EXCESSIVE PAINT BUILDUP ALONG THE TRAILING EDGE TO AVOID CHANGING BLADE PROFILE.

- (6) Apply sufficient finish coating to achieve 2 to 4 mils thickness when dry. Re-coat before 30 minutes, or after 48 hours. If the paint is permitted to dry longer than four (4) hours, it must be lightly sanded before another coat is applied.
- (7) Remove the masking from the tip stripes and re-mask to allow for the tip stripe refinishing if required.
- (8) Apply sufficient tip stripe coating to achieve 2 to 4 mils thickness when dry. Re-coat before 30 minutes, or after 48 hours. If the paint is permitted to dry longer than four (4) hours, it must be lightly sanded before another coat is applied.
- (9) Remove tape immediately from the de-ice boot and tip stripes, if required.
- (10) Optionally, perform dynamic balancing in accordance with the procedures and limitations specified in the Dynamic Balance section of this chapter.

6. Dynamic Balance

CAUTION: INSTRUCTIONS AND PROCEDURES IN THIS SECTION MAY INVOLVE CRITICAL PARTS. REFER TO THE INTRODUCTION CHAPTER OF THIS MANUAL FOR INFORMATION ABOUT PROPELLER CRITICAL PARTS. REFER TO THE ILLUSTRATED PARTS LIST CHAPTER OF THE APPLICABLE OVERHAUL MANUAL(S) FOR THE IDENTIFICATION OF SPECIFIC PROPELLER CRITICAL PARTS.

A. Overview

WARNING: WHEN USING REFLECTIVE TAPE FOR DYNAMIC BALANCING, DO NOT APPLY THE TAPE ON EXPOSED BARE METAL OF A BLADE. THIS WILL ALLOW MOISTURE TO COLLECT UNDER THE TAPE AND CAUSE CORROSION THAT CAN PERMANENTLY DAMAGE THE BLADE. REFLECTIVE TAPE MUST BE REMOVED AFTER DYNAMIC BALANCING IS COMPLETED.

NOTE: Dynamic balance is recommended to reduce vibrations that may be caused by a rotating system (propeller and engine) imbalance. Dynamic balancing can help prolong the life of the propeller, engine, airframe, and avionics.

- (1) Dynamic balance is accomplished by using an accurate means of measuring the amount and location of the dynamic imbalance.
- (2) The maximum permitted imbalance reading is 0.2 IPS.
- (3) The number of balance weights installed must not exceed the limits specified in this chapter.
- (4) Follow the dynamic balance equipment manufacturer's instructions for dynamic balance in addition to the specifications of this section.

NOTE: Some engine manufacturer's instructions also contain information on dynamic balance limits.

B. Inspection Procedures Before Balancing

- (1) Visually inspect the propeller assembly before dynamic balancing.

NOTE: The first run-up of a new or overhauled propeller assembly may leave a small amount of grease on the blades and inner surface of the spinner dome.

- (a) Use a Stoddard solvent (or equivalent) to completely remove any grease on the blades or inner surface of the spinner dome.
 - (b) Visually check each propeller blade assembly for evidence of grease leakage.
 - (c) Visually inspect the inner surface of the spinner dome for evidence of grease leakage.
- (2) If there is no evidence of grease leakage, lubricate the propeller in accordance with the Maintenance Practices chapter in this manual. If grease leakage is evident, determine the location of the leak and correct before re-lubricating the propeller and dynamic balancing.
 - (3) Before dynamic balancing, record the number and location of all balance weights.

C. Modifying Spinner Bulkhead to Accommodate Dynamic Balance Weights

CAUTION: ALL HOLE/BALANCE WEIGHT LOCATIONS MUST TAKE INTO CONSIDERATION, AND MUST AVOID, ANY POSSIBILITY OF INTERFERING WITH THE ADJACENT AIRFRAME, DE-ICE AND ENGINE COMPONENTS.

- (1) It is recommended that the placement of balance weights be in a radial location on aluminum spinner bulkheads that have not been previously drilled.
- (2) The radial location should be outboard of the de-ice slip ring or bulkhead doubler and inboard of the bend where the bulkhead creates the flange to attach the spinner dome.

- (3) Twelve equally spaced locations for weight attachment are recommended.
- (4) Install nut plates (10-32 thread) of the type used to attach the spinner dome, will allow convenient balance weight attachment on the engine side of the bulkhead.
- (5) Alternatively, drilling holes for use with the AN3-() type bolts with self-locking nuts is acceptable.

NOTE: Chadwick-Helmuth Manual AW-9511-2, "The Smooth Propeller", specifies several generic bulkhead rework procedures. These are acceptable providing they comply with the conditions specified herein.

D. Placement of Balance Weights for Dynamic Balance

- (1) The preferred method of attachment of dynamic balance weights is to add the weights to the spinner bulkhead.

NOTE: Many spinner bulkheads have factory installed self-locking nut plates provided for this purpose.

- (2) If the location of static balance weights has not been altered, subsequent removal of the dynamic balance weights will return the propeller to its original static balance condition.
- (3) Use only stainless or plated steel washers as dynamic balance weights on the spinner bulkhead.
- (4) Do not exceed a maximum weight per location of 0.9 oz. (25.5 g).

NOTE: This is approximately equal to six AN970 style washers (0.188 inch ID, 0.875 inch OD, 0.063 inch thickness) (4.78 mm ID, 22.23 mm OD, 1.60 mm thickness).

- (5) Install weights using aircraft quality #10-32 or AN-3() type screws or bolts.

- (6) Balance weight screws attached to the spinner bulkhead must protrude through the self-locking nuts or nut plates a minimum of one thread and a maximum of four threads.

NOTE: It may be necessary to alter the number and/or location of static balance weights in order to achieve dynamic balance.

- (7) If reflective tape is used for dynamic balancing, remove the tape immediately upon completion. Tape that remains on the blade will permit moisture to collect under the tape and cause corrosion that can permanently damage the blade.
- (8) Record the number and location of dynamic balance weights and static balance weights, if they have been reconfigured, in the logbook.

7. Propeller Ice Protection Systems

A. Electric De-ice System

- (1) Consult the Pilot Operating Handbook (including all supplements) regarding flight into conditions of known icing. The aircraft may not be certificated for flight in known icing conditions, even though propeller de-ice equipment is installed.
- (2) Refer to the Anti-ice and De-ice Systems chapter of this manual for functional tests of the de-ice system.

B. Anti-ice System

- (1) Consult the Pilot Operating Handbook (including all supplements) regarding flight into conditions of known icing. The aircraft may not be certificated for flight in known icing conditions, even though propeller anti-ice equipment is installed.
- (2) Refer to the Anti-ice and De-ice Systems chapter of this manual for functional tests of the anti-ice system.

(This page is intentionally blank.)

ANTI-ICE AND DE-ICE SYSTEMS - CONTENTS

1. Introduction	7-3
A. Propeller De-Ice System	7-3
B. Propeller Anti-ice System	7-3
2. System Description	7-4
A. De-ice System	7-4
B. Anti-ice System	7-5
3. De-ice System Functional Tests	7-5
4. Anti-ice System Functional Tests	7-5
5. De-ice and Anti-ice System Inspections	7-6
A. De-ice System Inspections	7-6
B. Anti-ice System Inspections	7-6
6. De-ice and Anti-ice System Troubleshooting	7-7
A. De-ice System Troubleshooting	7-7
B. Anti-ice System Troubleshooting	7-7

(This page is intentionally blank.)

1. Introduction**A. Propeller De-ice System**

- (1) A propeller de-ice system is a system that removes ice after it forms on the propeller blades. A de-ice system uses electrical heating elements to melt the ice layer next to the blades, allowing the ice to be thrown from the blade by centrifugal force. The de-ice system timer controls the application of current to the blades, alternately heating them and allowing them to cool.
- (2) System components include a timer or cycling unit, electrical slip ring(s), brush block assembly, and blade mounted de-ice boots.

B. Propeller Anti-ice System

- (1) A propeller anti-ice system is a system that prevents formation of ice on propeller surfaces. An anti-ice system dispenses a fluid that mixes with, and reduces the freezing point of, moisture on the propeller blades. The mixture may then flow off the blades before it forms ice.
- (2) System components include a fluid tank, pump, slinger ring, and blade mounted fluid anti-icing boots.

2. System Description**A. De-ice System**

NOTE: Because of the many differences in various de-ice systems, the following description is general in nature. Consult the airframe manufacturer's manual for a description of your specific de-ice system and controls.

The de-ice system is controlled by the pilot via a cockpit control switch. This switch applies power to the de-ice system, which will operate as long as the switch is in the ON position. Depending upon the system, another set of cockpit controls may be available. One of these controls is a mode selector, which allows the pilot to select two cycling speeds, for heavy or light icing conditions. Some systems on twin engine aircraft have a switch which provides a full de-ice mode, which allows the pilot to de-ice both propellers simultaneously. This switch may only be used for short periods and is used when ice builds up on the propeller before the system is turned on.

- (1) An ammeter, which indicates current drawn by the system, is normally located near the de-ice system switches. This meter may indicate total system load, or a separate meter may be supplied for each propeller.
- (2) A timer, which is turned off and on by the cockpit control, is used to sequence the de-ice system. This timer turns the de-ice system on and off in proper sequence, controlling the heating interval for each propeller blade and ensuring even de-icing.
- (3) A brush block mounted on the engine immediately behind the propeller supplies power to the de-ice boot on each propeller blade via a slip ring. The slip ring is normally mounted on the spinner bulkhead.
- (4) When the pilot places the de-ice system cockpit control switch in the ON position, the system timer begins to operate. As the timer sequences, power is delivered to a power relay. The power relay delivers high current through the brush block and slip ring to the de-ice boot.

B. Anti-ice System

- (1) The anti-ice system is controlled by the pilot via a cockpit mounted rheostat. This rheostat operates a pump that pumps anti-ice fluid from the tank at a controlled rate.
- (2) The anti-ice fluid is delivered through a filter, a check valve, and then through tubing to a slinger ring located at the rear of the spinner bulkhead. The anti-ice fluid is dispensed into the rotating slinger ring, which holds the fluid in a curved channel by centrifugal force. The fluid then flows out of the slinger ring through feed tubes which are welded to the slinger ring, and then out onto the blade anti-icing boots.
- (3) The blade anti-icing boots are ridged rubber sheets that are glued to the leading edge of the blades. The ridges in the anti-icing boots direct the fluid out onto the blades and permit for an even distribution of the anti-ice fluid across the blades.

3. De-ice System Functional Tests

A. Functional tests of the de-ice system should be performed in accordance with the following Hartzell Propeller Inc. manuals, which are available on the Hartzell Propeller Inc. website at www.hartzellprop.com.

- (1) Hartzell Propeller Inc. Manual 181 (30-60-81) - Propeller Ice Protection System Component Maintenance Manual
- (2) Hartzell Propeller Inc. Manual 182 (61-12-82) - Propeller Electrical De-ice Boot Removal and Installation Manual

4. Anti-ice System Functional Tests

A. Operational Checks of the anti-ice system should be performed in accordance with the following Hartzell Propeller Inc. manuals, which are available on the Hartzell Propeller website at www.hartzellprop.com:

- (1) Hartzell Propeller Inc. Manual 181 (30-60-81) - Propeller Ice Protection System Component Maintenance Manual
- (2) Hartzell Propeller Inc. Manual 183 (61-12-83) - Propeller Anti-icing Boot Removal and Installation Manual

5. De-ice and Anti-ice System Inspections

The inspections detailed below are made on a regular basis, either before flight, during the 100 hour inspection, or if a problem is noted. Possible corrections to problems discovered during inspections, additional inspections, and limits are detailed in the following Hartzell Propeller Inc. manuals, which are available on the Hartzell Propeller Inc. website at www.hartzellprop.com:

A. De-ice System Inspections

- (1) Perform inspections in accordance with the following Hartzell manuals, which are available on the Hartzell Propeller Inc. website at www.hartzellprop.com:
 - (a) Hartzell Propeller Inc. Manual No. 181 (30-60-81) - Propeller Ice Protection System Component Maintenance Manual
 - (b) Hartzell Propeller Inc. Manual No. 182 (61-12-82) - Propeller Electrical De-ice Boot Removal and Installation Manual.

B. Anti-ice System Inspections

- (1) Perform inspections in accordance with the following Hartzell Propeller Inc. manuals, which are available on the Hartzell Propeller website at www.hartzellprop.com:
 - (a) Hartzell Propeller Inc. Manual 181 (30-60-81) - Propeller Ice Protection System Component Maintenance Manual
 - (b) Hartzell Propeller Inc. Manual 183 (61-12-83) - Propeller Anti-icing Boot Removal and Installation Manual

6. De-ice and Anti-ice System Troubleshooting**A. De-ice System Troubleshooting**

(1) Perform troubleshooting in accordance with the following Hartzell Propeller Inc. manuals, which are available on the Hartzell Propeller Inc. website at www.hartzellprop.com:

(a) Hartzell Propeller Inc. Manual 181 (30-60-81) - Propeller Ice Protection System Component Maintenance Manual

(b) Hartzell Propeller Inc. Manual 182 (61-12-82) - Propeller Electrical De-ice Boot Removal and Installation Manual

B. Anti-ice System Troubleshooting

(1) Perform troubleshooting in accordance with the following Hartzell Propeller Inc. manuals, which are available on the Hartzell Propeller Inc. website at www.hartzellprop.com:

(a) Hartzell Propeller Inc. Manual 181 (30-60-81) - Propeller Ice Protection System Component Maintenance Manual

(b) Hartzell Propeller Inc. Manual 183 (61-12-83) - Propeller Anti-icing Boot Removal and Installation Manual

(This page is intentionally blank.)

CONTENTS

1. Introduction 8-3

2. Record Keeping 8-3

 A. Information to be Recorded 8-3

(This page is intentionally blank.)

1. Introduction

Federal Aviation Regulations require that a record be kept of any repairs, adjustments, maintenance, or required inspections performed on a propeller or propeller system.

This chapter provides a method for maintaining these records. It also provides a location for recording information that can aid the service technician in maintaining the propeller system.

2. Record Keeping**A. Information to be Recorded**

- (1) Information which is required to be recorded is listed in Part 43 of the U.S. Federal Aviation Regulations.
- (2) The log book may also be used to record:
 - (a) Propeller position (on aircraft)
 - (b) Propeller model
 - (c) Propeller serial number
 - (d) Blade design number
 - (e) Blade serial numbers
 - (f) Spinner assembly part number
 - (g) Propeller pitch range
 - (h) Aircraft information (aircraft type, model, serial number and registration number)

(This page is intentionally blank.)